



PE Series

Operator's Manual

CG Triumvirate is a trademark of Agfa Corporation.

CG Times, based upon Times New Roman under license from The Monotype Corporation.

SEAQ is a trademark of Datamax Barcode Products Corporation.



As an Energy Star Partner, Datamax Corporation has determined that this product meets the Energy Star guidelines for energy efficiency.

Firmware (Software) Agreement: The enclosed Firmware (Software) resident in the EPROM's is owned by Licensor or its suppliers and is licensed for use only on a single printer in the user's Trade or Business. **The User agrees not to, and not to authorize or permit any other person or party to, duplicate or copy the EPROM's or the information contained in the EPROM's.** The firmware (Software) is protected by applicable copyright laws and Licensor retains all rights not expressly granted. In no event will Licensor or its suppliers be liable for any damages or loss, including direct, incidental, economic, special, or consequential damages, arising out of the use or inability to use the Firmware (Software).

Information in this document is subject to change without notice and does not represent a commitment on the part of Datamax Barcode Products Corporation. No part of this manual may be reproduced or transmitted in any form or by any means, for any purpose other than the purchaser's personal use, without the expressed written permission of Datamax Corporation.

© Copyright 1998 by Datamax Corporation

All rights reserved. Printed in the United States of America.

88-2082-01 Rev. C1

Agency Compliance and Approvals

UL: UL1950 Safety of Information Technology Equipment

1. Nur für Gebrauch innerhalb eines Gebäudes geeignet.

Für 230 Volt (Europa): Benützen Sie ein Kabel, das mit "HAR" markiert ist, bestehend mindestens aus einem H05VV-F Kabel, das mindestens 0,75 Quadratmillimeter Drahtdurchmesser hat; sowie eine IEC320 Steckdose und einen für das Land geeigneten Stecker, 6A, 250 Volt.

1. This unit is intended for indoor use only.
2. Disconnect power supply cord in case of emergency.
3. When power supply cord is not provided; for proper power supply cord selection please see below:

CE: This product complies with requirements of the Low Voltage Directive 73/23/EEC and the provisions of the EMC Directive 89/336/EEC.

For 230 Volt Operation (Europe): Use a cord set, marked "HAR," consisting of a min H05VV-F cord which has a minimum 0.75 square mm diameter conductors, provided with an IEC 320 receptacle and a male plug for the country of installation rated 6A, 250V

For 120 Volt Operation (Domestic):

FCC: This device complies with FCC CFR 47 Part 15 Class A.

Note: This equipment has been tested and found to comply with the limits for a Class A digital device, pursuant to Part 15 of the FCC Rules. These limits are designed to provide reasonable protection against harmful interference when the equipment is operated in a commercial environment. This equipment generates, uses, and can radiate radio frequency energy, and if not installed and used in accordance with the instructions in this manual, it may cause harmful interference to radio communications. Operation of this equipment in a residential area is likely to cause harmful interference in which case the user will be required to correct the interference at his own expense.

Important Safety Instructions

This printer has been carefully designed to give you many years of safe, reliable performance. As with all electrical equipment, there are a few basic precautions you should take to avoid hurting yourself or damaging the printer.

Carefully read the installation and operating instructions provided with your printer.

Read and follow all warning instruction labels on the printer.

Mount the printer to a flat, firm, solid surface.

To protect your printer from overheating, make sure all openings on the printer are not blocked.

Do not place the printer on or near a heat source.

Do not use your printer near water, or spill liquid into it.

Be certain that your power source matches the rating listed on your printer. If you are unsure, check with your dealer or with your local power company.

Do not place the power cord where it will be walked on. If the power cord becomes damaged or frayed replace it immediately.

Do not insert anything into the ventilation slots or openings on the printer.

Only qualified, trained service technicians should attempt to repair your printer.

Contents

Printer Overview

1.0	Introduction	1
1.1	About This Printer.....	2
1.1.1	Standard Features.....	2
1.1.2	Optional Features.....	3

Getting Started

2.0	Before Using This Printer.....	5
2.1	General Overview.....	7

Setting Up the Printer

3.0	Introduction	9
3.1	Connecting the Printer.....	9
3.2	Loading Media.....	10
3.3	Loading Ribbon (Thermal Transfer).....	13
3.4	Ribbon Removal	15
3.5	Installing a FLASH Cartridge	17
3.6	Printing a Configuration Label.....	19
3.7	Configuration Label Explanation.....	22
3.8	Test Pattern Label.....	23
3.9	Applicator Connection.....	24
3.10	Options Port.....	26

Using Your Printer

4.0	Using the Printer's Front Panel	28
4.1	Accessing the Menu Tree	30
4.1.1	Basic Functions	30
4.1.2	Advanced Setup	32

Printer Adjustments

5.0	Introduction	42
5.1	Media Sensor Adjustment.....	42
5.2	Media Width Adjustment.....	43
5.3	Label Start of Print.....	44
5.4	Label Presentation.....	44
5.5	Setting Start of Print and Peel Position.....	45
5.6	Controlling Print Quality.....	46

Maintenance

6.0	Introduction	48
6.1	Cleaning Schedule.....	49
6.2	Cleaning the Printhead.....	50
6.3	Cleaning the Platen Roller.....	51

Troubleshooting

7.0	Introduction	52
7.1	Troubleshooting Tips	52
7.2	Error Messages	56
7.3	Character Dump Mode	61

Appendices

Appendix A

ASCII Control Chart.....	A-1
--------------------------	-----

Appendix B

Available Fonts and Barcodes.....	B-1
Human-Readable Fonts.....	B-2
Barcode Fonts.....	B-5

Appendix C

Cable Listing.....	C-1
--------------------	-----

Appendix D

Applicator Port Test Box.....	D-1
-------------------------------	-----

Appendix E

Error Codes.....	E-1
------------------	-----

Appendix F

Printer Specifications.....	F-1
Printer Dimensions.....	F-4
Media Specifications.....	F-5
Media and Ribbon Basics.....	F-6

Appendix G

Menu Tree.....	G-1
----------------	-----

Appendix H

Warranty Information.....	H-1
---------------------------	-----



Printer Overview

1.0 Introduction

The PE Series, hereafter referred to as the printer, is a high quality, high volume, extremely durable print engine, designed exclusively for use with label applicator systems.

Available in a wide range of configurations, the printer offers both direct thermal or thermal transfer printing and comes equipped with many popular bar codes, nine resident fonts, a smooth bit-mapped font (CG Triumvirate) and a scaleable font (CG Triumvirate Bold Condensed).

This manual provides all the information necessary to operate the printer. To print labels or tags, simply refer to the instructions included with the software you have chosen to create your labels.

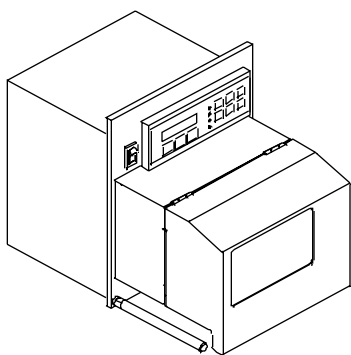

Right-Hand Model

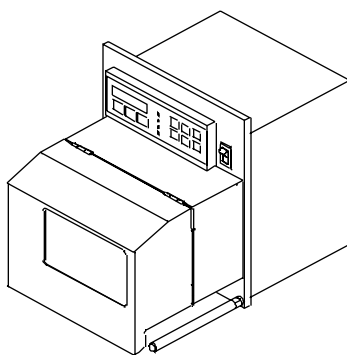

Left-Hand Model

Figure 1-1 PE Series Print Engines

1.1 About This Printer

This printer offers the following standard and optional features:

1.1.1 Standard Features

Advanced Technology

This printer utilizes the Intel I960 32 Bit RISC Microprocessor and Datamax application specific integrated circuitry (ASIC).

The ASIC design includes highly integrated components, along with the Datamax proprietary SEAQ Circuit, which maintains printhead thermal control to provide consistent print quality.

Interfaces

This printer is equipped with two serial data communication interfaces that support RS-232, RS-422, or RS-485 and one Centronics® parallel data communication interface. The printer is easily connected to any host using one of the cable configurations listed in Appendix C.

Control Panel

The detachable/rotatable printer control panel has one liquid crystal display (LCD), three LEDs, three primary operational keys and six additional menu keys.

1.1.2 Optional Features

300 DPI

This factory installed option provides a printhead resolution of 300 dots per inch with a 4.16 inch print width and 1MB DRAM.

Left-Hand

Left-hand label output model for system configuration flexibility.

Memory Expansion

On-board memory DRAM expansion to 4 MB total for expanded print length, temporary image storage and scaleable font character cache.

FLASH Cartridge

A removable module used for permanent storage of custom fonts, format and graphics. Available in 256K, 512K, 1 MB and 2 MB sizes.

Ribbon Saver

This factory installed option eliminates ribbon waste when feeding past non-printed label areas.



Getting Started

2.0 Before Using This Printer

Unpacking the Printer

The printer was carefully packaged to avoid any damage during transit. Before opening, closely inspect the box for damages. In the event of shipping damage, contact the carrier immediately regarding its nature and extent.

In order to operate the printer you will need to remove the packaging materials that are placed inside the printer for shipment. Complete the following steps before connecting power. It may be helpful to refer to Figure 2-2 when removing the packing material.

- ❶ Remove the printer from the box.
- ❷ Remove the printer from the plastic bag.
- ❸ Remove the tape that extends over the printhead assembly.
- ❹ Remove the piece of foam between the printhead and platen.
- ❺ Remove the tape that covers the J-Hook on the Ribbon Take-Up Hub.

<p><input checked="" type="checkbox"/> Note: Save all packaging materials in the event that shipping the printer is ever required.</p>

Inspecting the Printer

After removing the printer from the box, check the remaining contents of the package. In addition to this manual, the following items should be present:

- label printer installation guide
- sample print labels
- power cord
- any special or additional items purchased

Additional Requirements

The following items are necessary for generating labels with your printer. Contact your dealer or a technical support representative for advice on media and software.

- Serial or parallel interface cable (see Appendix C).
- Applicable media (see Appendix F).
- Applicable software

2.1 General Overview

The following illustrations show the major components of your printer. It may be helpful to refer back to this section for the names and locations of the printer's various parts.

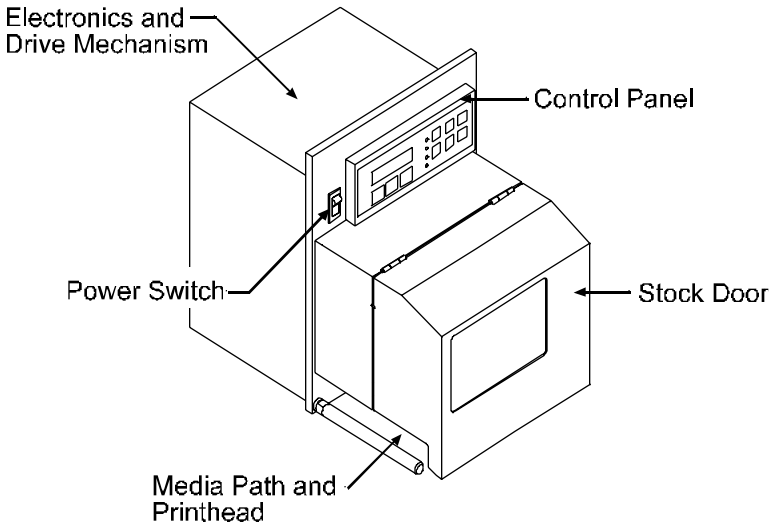

Figure 2-1 Right-Hand Model, External Front View

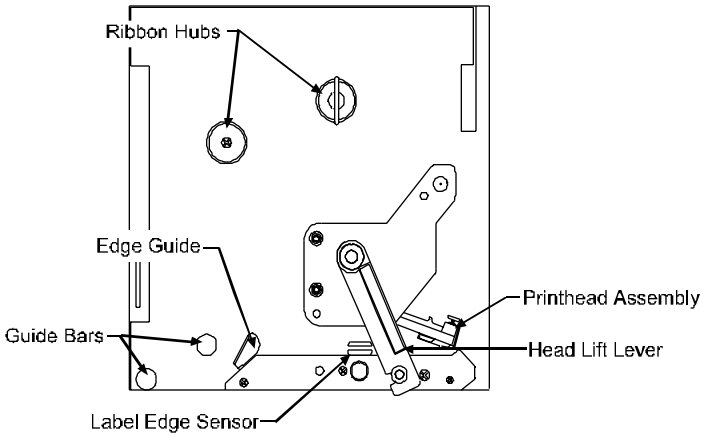

Figure 2-2 Right-hand Model, Interior Front View

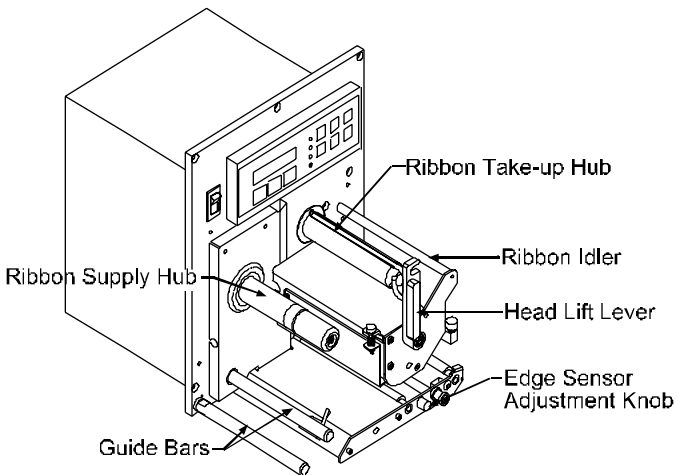

Figure 2-3 Right-Hand Model, Media Path



Setting Up the Printer

3.0 Introduction

This chapter explains how to connect the printer to the host, load media and print a configuration label.

3.1 Connecting the Printer

Note: Ensure that the printer's power switch is 'off' when connecting the AC power cord or any interface cable.

Connect the AC power cord to the back of the printer before plugging into a properly grounded outlet. The printer can be connected to the host computer with a parallel or serial cable, (see Appendix C). The applicator connections should also be made at this time. The figure below shows the position of the interface ports.

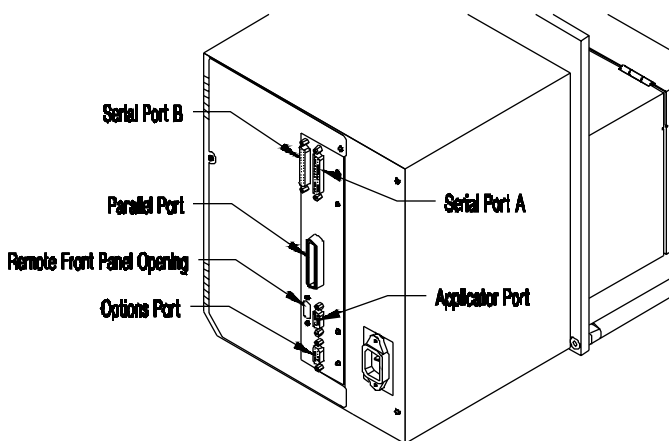

Figure 3-1 Connecting the Printer

3.2 Loading Media

This section explains the loading of media.

- 1 Move the Head-Lift Lever 'up' to raise the printhead, as shown in Figure 3-2.

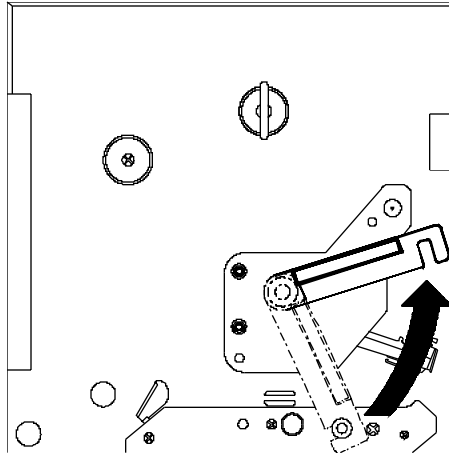

Figure 3-2 Head-Lift Lever

- 2 Push 'up' on the hinged Drive Plate at the point shown in Figure 3-3. This will release the plate, allowing it to swing down.

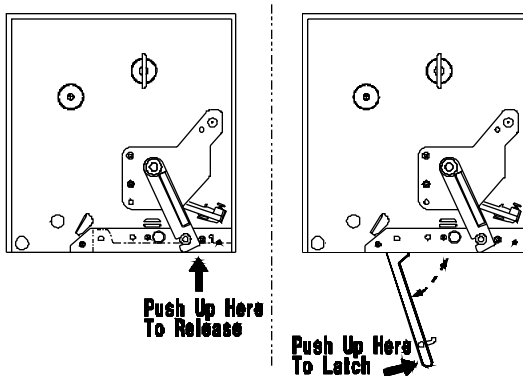

Figure 3-3 Opening and Closing the Drive Plate

- 5 Peel the first 12 inches of label material from the liner and discard.

☑ Note: If you wish to leave the label attached to the liner do not thread the media through the Drive Plate.

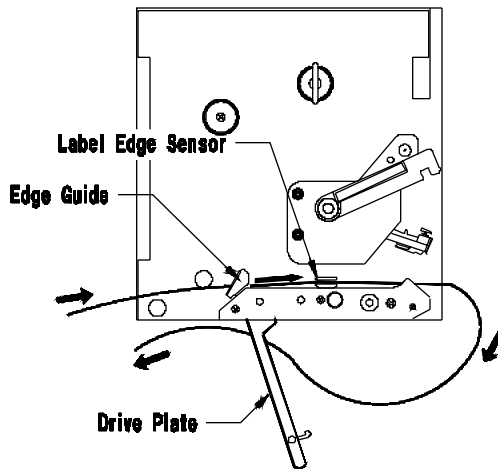

Figure 3-4 Media Loading

- 4 Feed the liner as shown in Figure 3-4. Be sure that the liner passes through the “fingers” of the Label Edge Sensor. Continue feeding the liner, bringing it under the Drive Plate Hinge Pin (see Figure 3-5). Pull through removing any slack.

☑ Note: When using narrow media, it may be necessary to adjust the position of the Label Edge Sensor to ensure detection. This is done by turning the Edge Sensor Adjustment Knob (see Figure 2-3).

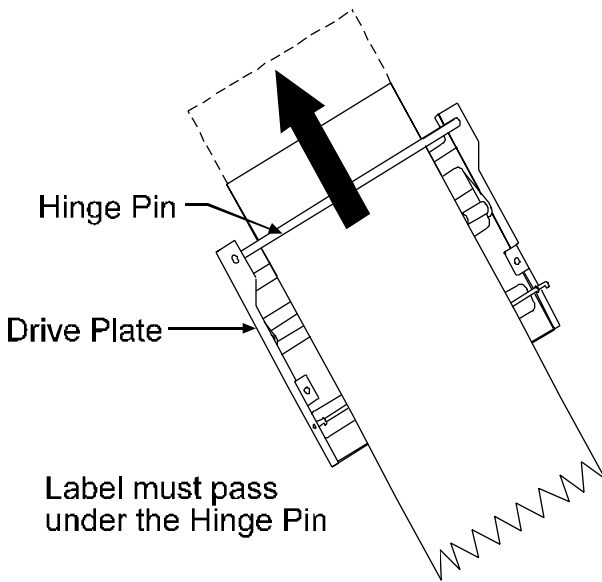

Figure 3-5 Media Loading (detail)

- ⑤ To close, raise the Drive Plate back up, until the plate snaps into place. See Figure 3.3.
- ⑥ Lower the Head-Lift Lever until the printhead is locked in the down position.

3.3 Loading Ribbon (Thermal Transfer)

The printer can use two methods to create an image on the media. The first method, called direct thermal, uses specially treated label stock containing dyes that turn black with heat and pressure.

The second method is thermal transfer, which involves the transfer of ink from a ribbon substrate onto the media with heat and pressure. The ink is transferred to the label stock as it passes between the printhead and the platen roller. To use this method, set the printer to “transfer” before printing.

☑ Note: Ribbon should never be used with direct thermal stock. Using this stock with a ribbon will result in poor quality print.

Complete the following steps to load ribbon:

- ❶ Unlatch and raise the printhead.
- ❷ Slide the ribbon roll onto the Ribbon Supply Hub with the leader coming over the top of the roll. Ensure that the ribbon roll is pushed back fully against the flange at the base of the Ribbon Supply Hub.
- ❸ Thread the ribbon along the path as shown in Figure 3-6.

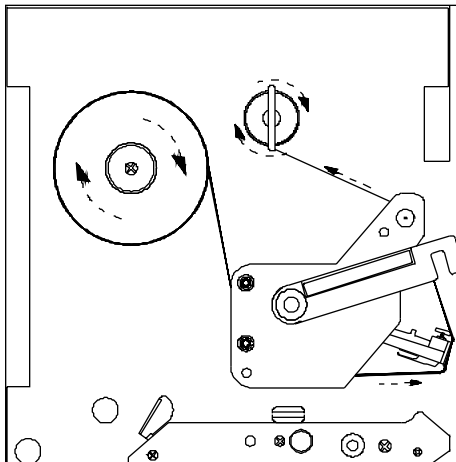

Figure 3-6 Ribbon Loading Path

- ④ Remove the J-Hook from the Ribbon Take-up Hub, (as a convenient option you may use an empty ribbon core to rewind the spent ribbon, if using this method do not reinstall the J-Hook).
- ⑤ While holding the Ribbon Take-up Hub, rotate the J-Hook to unlatch it.
- ⑥ Raise the J-Hook away from the hub and place the end of the ribbon over the take-up hub.

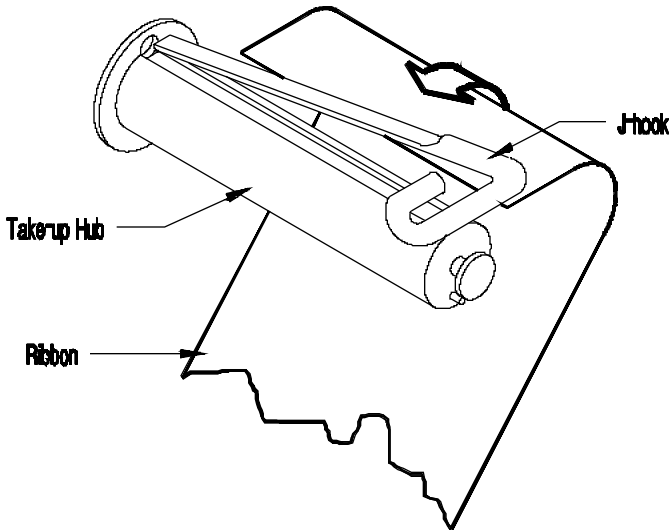

Figure 3-7 J-Hook

- ⑦ Slide the J-Hook back into place as shown in Figure 3-7. While holding the Ribbon Take-up Hub, rotate the J-Hook until it latches. Turn the Ribbon Take-up Hub several times to secure the ribbon.
- ⑧ Lower the Head Lift Lever until the printhead is locked in the down position.

3.4 Ribbon Removal

Removal of a Partially Used Roll of Ribbon

Complete the following steps to remove and save a ribbon:

- 1 Cut the ribbon at the point shown in Figure 3-8.
- 2 Turn the Ribbon Take-up Hub until the end of the ribbon has cleared the printhead area.
- 3 Grasp the roll of used ribbon and slide the used ribbon straight off the Ribbon Take-up Hub. Discard the used ribbon.
- 4 Grasp the roll of unused ribbon, pull and slide the unused ribbon from the Ribbon Supply Hub, storing it for future use.

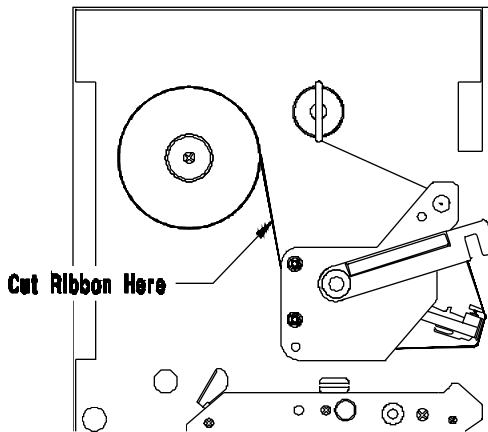

Figure 3-8 Ribbon Cutting Point

Removal of a Completely Used Ribbon

Complete the following steps to remove a completely used ribbon:

- ❶ Unlatch and raise the printhead.
- ❷ Rotate the Ribbon Take-up Hub, winding it until the ribbon clears the media path.
- ❸ Rotate the J-Hook, unlatch and remove.
- ❹ Grasp the roll of used ribbon and pull it straight off of the Ribbon Take-up Hub and discard.
- ❺ Pull the empty ribbon supply core from the Ribbon Hub. Save the core for later use on the Ribbon Hub or discard.

Supply
Take-Up

3.5 Installing a FLASH Cartridge

FLASH cartridges provide the same features as DRAM, with the added benefit of providing permanent storage for custom fonts, label formats and images. FLASH memory is essentially a non-volatile, electronically erasable PROM. A write protect switch on the cartridge is used to safeguard stored data against accidental erasure.

To install a memory cartridge:

- ❶ Turn 'off' and unplug the printer.
- ❷ Remove the two screws securing the Electronics Access Panel and open to reveal the connector, see figure below.

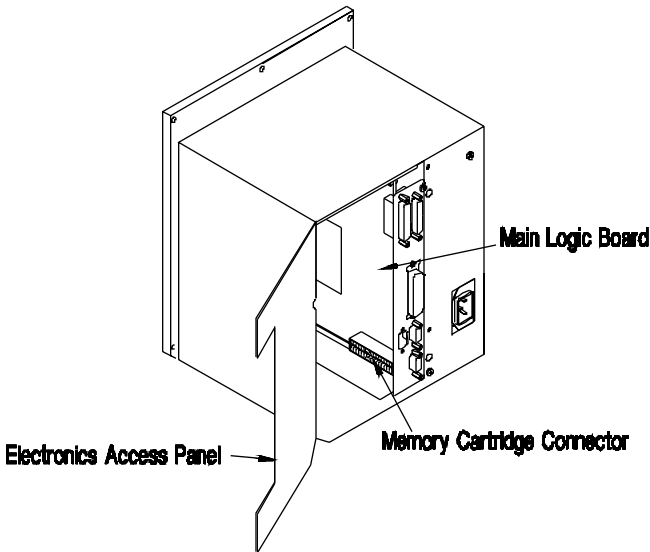

Figure 3-9 FLASH Cartridge Connector Location

- 3 Holding the FLASH Cartridge with the label facing up, insert it into the connector, see Figure 3-10. Push firmly, but do not force it, doing so could damage the cartridge and socket.

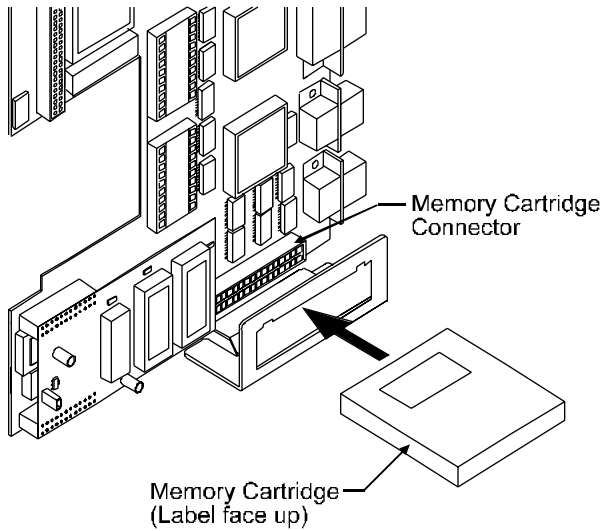

Figure 3-10 Inserting the Memory Cartridge

- 4 Close the Panel and secure it with the screws. Plug in and turn 'on' the printer. The printer will refer to the FLASH Cartridge as Module B.

3.6 Printing a Configuration Label

Before beginning, load the printer with 4” wide media or configure the Label Width Adjustment in the Advanced Setup Menu to meet your label width, (for thermal transfer, also use a matching ribbon. For direct thermal labels, be sure that “Direct” has been selected in the "Print Method"). See Section 4 for more setup information. To print a Configuration Label:

- ❶ Turn the printer ‘Off’.
- ❷ Press and hold the ‘Feed’ button while turning the printer ‘On’.
- ❸ Release the ‘Feed’ button after the printer display reads ‘DYNAMIC RAM DIAGNOSTICS’...

After a brief period, the labels will be printed. (If the labels are not printed, see Section 7). Referring to Figure 3-11, the Configuration Label contains two types of information. The first type is printer setup data. The second is a pattern, testing the print circuitry. In addition, a special connector can be used to test communications, see Section 4 on Serial Loopback for more details.

<p>☑ Note: After running the Configuration Label, the printer will enter Character Dump Mode and must be reset in order to run a label application. To reset, power the printer ‘Off’ and then ‘On’. For Character Dump Mode information see Section 7.</p>
--

COMMUNICATION OPTIONS		BASIC FUNCTIONS	
INPUT PORT	PORT A	PRINT METHOD	TRANSFER
BAUDRATE	9600	SELECT TOF	GAP
PARITY	NONE	DARKNESS	33
WORD LENGTH	8 BIT	CUTTER	DISABLE
STOP BITS	1	RIBBON SAVER	DISABLE
PROTOCOL	BOTH	INTERNAL BATCH	DISABLE
CONTROL CODES	STANDARD	CONVERSION	DECIMAL
		TOP ADJUST	64
OPERATION		COMPATABILITY	
PAUSE MODE	DISABLE	DPI EMULATION	203
FEEDBACK MODE	DISABLE	OFFSET BIAS	220
TEST MODE	DISABLE	HARDWARE	
LABEL OPTIONS		BATTERY LEVEL	GOOD
HEAT SETTING	10	THERMISTOR ADC	65
PRINT SPEED	6.0 IPS	REFLECTIVE ADC	0
SLEW SPEED	8.0 IPS	TRANSMISSIVE ADC	165
BACKFEED SPEED	5.0 IPS	PAPEROUT ADC	0
ROW ADJUST	0 in	INSTALLED OPTIONS	
COLUMN ADJUST	0 in	RIBBON SAVER	NO
LABEL WIDTH	410 in	CUTTER	NO
CONT. LABEL LEN	0 in	PE SIGNALLING	
PRESENT DIST	320 in	PE APPLY HW	DISABLE
PE INFORMATION		PE EXT SIGNAL	LOW PULSE
LOW RIBBON INCHES	20	RIBBON LOW ACTIVE	LOW
PRINTER MODEL	RIGHT	BACKFEED CONTROL	20ms
TUE FEBRUARY 17, 1998 14:07 048		COUNTER INFORMATION	
DATABASE INFORMATION		ABSOLUTE VALUES	02-10-98
SECURITY	NONE	LENGTH	11644 INCHES
VER: HA - 02.30 02/07/98		MEMORY CONFIGURATION	
ROM CHECKSUMS		INTERNAL MODULE	32
U39 47-2081-03K		SCALABLE FONTS	0
U37 47-2080-03K		SYMBOL SET	PC-850 MODIFIED
U38 47-2166-01B			
U40 47-2067-01B			
SYSTEM RAM CHECKS	GOOD		
SYSTEM RAM SIZE	512 KBYTES		
SERIAL LOOPBACK CHECK	GOOD*		
CTS & DTR LOOPBACK CHECK	GOOD*		

* ONLY PRESENT WITH SPECIAL TEST PLUG

Figure 3-11 Configuration Label

Note: Your Configuration Label may vary due to the printer configuration or the printer firmware version.

3.7 Configuration Label Explanation

February 17, 1998 14:13 048 - Printer date and time, including Julian calendar date.

Database Information--Includes serial number, security setting, firmware version, ROM Checksums, and the amount of DRAM. Serial Loopback Check and CTS/DTR Loopback Check results (if equipped with the proper test plug, see Section 4, Figure 4-1).

Counter Information--Includes the absolute counter values (the total amount of media through the printer, in inches) and the total number of hours in operation.

Memory Configuration--Lists the amount of Printer memory allocated for Internal Modules or Scaleable Fonts in 4 KB blocks.

Label Options--Lists label related settings.

PE Information--Specifies Printer model and the Low Ribbon Warning setting.

Hardware--Lists the current readings of some Printer sensors.

Installed Options--Lists the Printer's options.

PE Signaling--Lists the settings for applicator interfacing and backfeed control.

Communication Options--Lists all communication settings including the active port.

Operation--Indicates the operations that are available, and whether or not they have been enabled.

Basic Functions--Lists the settings for the Basic Function Menu.

Compatibility--(PE 42 only) Changes the dots per inch.

3.8 Test Pattern Label

The second of the labels is the Test Pattern Label, see Figure 3-12. This matrix is useful to determine the Printhead condition. For more information concerning maintenance, see Section 6.

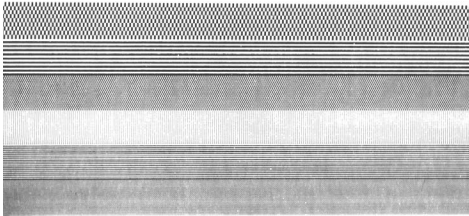

Good test label indicates Printhead is operating normally.

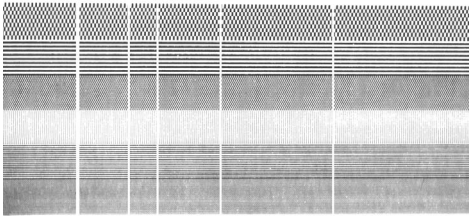

Streaks in test label indicate a dirty or faulty Printhead. (See Chapter 6 for cleaning instructions).

Figure 3-12 Test Pattern Label

3.9 Applicator Connection

The applicator mechanism will receive the printed label and affix it to an item. Applicator configuration and its communication with the printer must be coordinated. The applicator interfaces into the printer's DB-9P Applicator Port. The table below lists the functions. (Direction is given relative to the Printer.)

Note: All output signals are open collector.

Pin #	Function	Direction
1	+5 Volt Output	Out
2	Ribbon Low signal	Out
3	Machine Error	Out
4	(Not used)	N/A
5	Start Print signal	In
6	End Print signal	Out
7	Label Out signal	Out
8	Ribbon Out signal	Out
9	Signal Ground	N/A

Table 3-1 Applicator Port Pin Assignments

Pin function explanation:

Pin 1 - The Printer provides a +5 VDC, Output, fused at 1A.

Pin 2 - The Ribbon Low signal goes low when the diameter of the ribbon supply is at the LOW RIBBON INCH setting in the setup menu. See Section 4 for more information.

Pin 3 - The signal goes low when the Printer detects a Cover Open, Head Open, or Buffer Full error condition. It stays low until the error condition is corrected.

Pin 4 - Not Used

Pin 5 - The Start Print signal is sent from the Applicator to the Printer when the Applicator is ready to begin another cycle. Also, data from the host must be sent to the Printer before the Start Print signal is sent from the Applicator. See Appendix D for a test box schematic.

Pin 6 - The End Print signal is sent from the Printer to the Applicator when a printed label is ready for the Applicator. The signal is used to synchronize a device with the print cycle. The End Print signal can be set for one of five types through the menu, see Figure 3-13. The options are:

- A Low Pulse (0V for 30 msec.) at the end of print.
- A High Pulse (5V for 30 msec.) at the end of print.
- A steady Low signal (0V) throughout the print cycle.
- A steady High signal (5V) throughout the print cycle.
- Disabled.

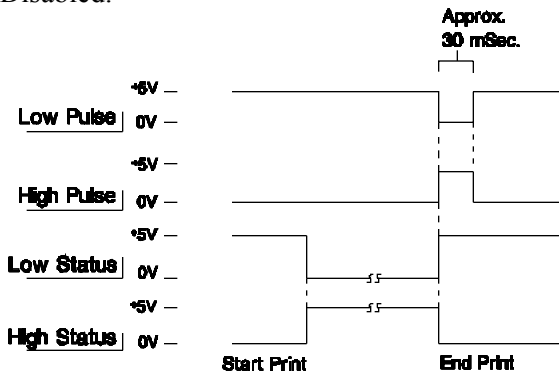

Figure 3-13 "End Print" Signal Options

Pin 7 - The Label Out signal goes low when the Printer is out of stock.

Pin 8 - The Ribbon Out signal goes low when the Printer is out of ribbon. (When this signal goes low, the Ribbon Low signal on Pin 2 resets to high.)

Pin 9 - Signal Ground.

3.10 Options Port

The Options Port is used for external control of the printer via discrete lines. The Port consists of +5V, Ground, three outputs, and four inputs. This port can be manipulated via DPL (Datamax Programming Language). For more information consult the Programmer's Manual.

PIN #	Description
1	+5 VDC, Fused 5A
2	Output 1, 7406 Open Collector
3	Output 2, 7406 Open Collector
4	Output 3, 7406 Open Collector
5	Input 1, Inverting Schmitt Trigger
6	Input 2, Inverting Schmitt Trigger
7	Input 3, Inverting Schmitt Trigger
8	Input 4, Inverting Schmitt Trigger
9	Ground

Table 3-2 Options Port Pin Assignments



Using Your Printer

4.0 Using the Printer's Front Panel

The printer's detachable/rotatable front panel contains nine buttons, three lights and a 2x16 character display with contrast adjustment. The functions and features are as follows:

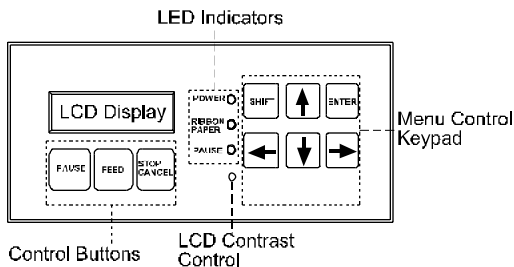

Figure 4-1 Front Panel

Control Buttons

Pause This button temporarily stops the current print job. Printing will resume when pressed a second time.

Feed Pressing this button will feed one label. When pressed during a print job, the label will feed upon completion of the job. Also, pressing Feed will clear an alarm condition.

Cancel Pressing this button one time will clear the current job, pause the printer, and prepare the next job (if any). When more than one job has been sent to the printer, only the current job is canceled, all other jobs are unaffected. However, repeatedly pressing this button will remove the remaining jobs from the cue, one by one.

Lights

Power This illuminates when the printer is powered 'on'. A delay of up to one second is normal at 'power up' or 'power down'.

Ribbon/Paper This illuminates to indicate a fault in the media or ribbon path. Rapid flashing indicates a low-ribbon condition.

Pause This illuminates when the printer is paused and is 'off' when the printer is at Ready.

Menu Keypad

↔ ↑ ⇨ ↓ The four arrow keys are used to move through the printer's menu tree, scroll through options and increment or decrement certain definable values. In general, ↑ and ↓ move to the next higher or lower menu level, while ↔ and ⇨ scroll through the choices within the same level. See Appendix G.

Enter Selects the option currently displayed.

Shift Used to change fields on certain menu items. (e.g. Comm Setup/Serial parameters)

LCD Contrast

Allows the user to change the intensity of the display. Use a small screwdriver to adjust the display contrast. Turning the potentiometer counter-clockwise increase the contrast.

4.1 Accessing the Menu Tree

The menu is divided between basic function and advanced setup levels. (To see a complete overview, the Menu Tree is located in Appendix G.)

Note: Default values or settings may vary depending on the version and customer applications. Factory default settings will be indicated with * symbol.

4.1.1 Basic Functions

There are nine basic functions including a gateway to the advanced setup level.

Print Method	Column Adjust
Sensor Top of Form	PE Applicator HW
Darkness	Advanced Setup
Start of Print	

LCD :

```
TUE FEB03 11:55A
READY
```

From the Printer Ready screen, enter the Basic Function screen by pressing the ↓ key :

Print Method

Direct
*Transfer

Controls the type of print method to be used.
Enables direct-thermal printing (no ribbon).
Enables thermal-transfer printing (ribbon installed).

Select TOF

*Gap
Reflective
Continuous

Controls the type of media sensing to be used.
Senses on a gap or notch between each label.
Senses on a reflective mark between each label.
Senses only presence, TOF set by label format.

Darkness

*Factory preset
Value range: 1-64

Fine tunes the print contrast level. Used to match print contrast level when replacing the printhead.

Selectable with 64 indicating maximum darkness.

Start of Print

*Factory preset Value
range: 0-128

Fine tunes the horizontal print position on the label. Allows a matching start of print position between multiple printers sharing the same label formats.

Zero is forward, while 128 is the furthest back.

Column Adjust

* Factory preset value
range: 0-128

Fine tunes the print position to the left or right on the label. Zero is all the way to the left.

PE Applicator H W

Enable
*Disable

Switches control of print cycle operation, applicator port pin #5 on or off.

Enables an applicator to control the print cycle.
Ignores any applicator signal.

Advanced Setup

Press the \downarrow to access to the printer's advanced options.

4.1.2 Advanced Setup

Advanced setup is a gateway leading to additional system, maintenance and testing sub-levels.

PE Options	System Options
Low Ribbon Diameter	Compatibility
Printer Model	Operation
Counters	Communications
Date/Time	Maintenance
Label Options	Modules

LCD :

```
BASIC  FUNCTION
ADVANCED SETUP
```

From Basic Function/Advanced Setup, enter by pressing the ↓ key:

PE Options

Three selections used to integrate functions with an applicator.

PE Output Signal

Selects the type of status signal used between the printer and applicator port pin #6.

*Low Pulse	High to low signals end of print cycle.
High Pulse	Low to high signals end of print cycle.
Low Status	Steady low signal during printing.
High Status	Steady high signal during printing.
Disable	No print and apply function.

PE Options (cont.)

Backfeed Cntrl

*20 ms after print
40 ms after print
60 ms after print
80 ms after print
99 ms after print
no backfeed
before print

Controls the timing associated with the backfeeding of a presented label.

20 millisecond delay before printing the next label.
40 millisecond delay before printing the next label.
60 millisecond delay before printing the next label.
80 millisecond delay before printing the next label.
99 millisecond delay before printing the next label.
Disables all backfeed motion.
Backfeeds without delay, upon next print cycle.

Ribbon Low

*Active Low
Active High

Sets the output polarity of the applicator port pin #2 ribbon low signal.

Signal goes low for ribbon low condition.
Signal goes high for ribbon low condition.

Ribbon Low Dia

.

*20

Value range: 14-34

Allows user to select how much ribbon will remain when a Low Ribbon message is displayed.

The value selected is the remaining diameter in tenths of an inch.

Printer Model

*Left Hand
*Right Hand

Instructs the printer of the mechanism's configuration for printhead zero dot orientation.

Right side label output.
Left side label output.

Counters

Absolute Values

Read only check of the printer's absolute values.

Given in inches; not resettable.

Date/Time

Allows the current date and time fields to be changed.

Label Options

Allows access to six label parameters.

Heat Setting

*10

Value range: 0-30

Allows the selection of different heat settings.
Changes the "on time" of the printhead dots.

The higher value, the darker the print.

Label Options (cont.)

Print Speed

Allows the selection of different rates that the label will be printed.

*6.0 ips

Value range:
model dependent

PE 42; 2 to 10 ips (51 - 254 mm/sec)

PE 43; 2 to 8 ips (51 - 203 mm/ sec)

Slew Speed

Allows the selection of different rates that the printer will feed during non-printed portions of each label.

*8.0 ips

Value range:
model dependent

PE 42; 2 to 10 ips (51 to 254 mm/sec)

PE 43; 2 to 8 ips (51 - 203 mm/sec)

Backfeed Speed

Allows the selection of different rates that the printer will backup labels.

*5.0 ips

Value range:
2.0 -5.0 ips

Range is the same for both models.

Label Width

Changes useable label width, as when printing on media narrower than 4.1 inches; reducing width increases memory for label formatting. Also allows printing of Configuration Labels on narrow media. The printer must be reset for the new value to be recognized.

*410 or
416, respectively
Value range:

PE 42; 100 to 410 (1.00 to 4.10 in.)

PE 43: 100 to 416 (1.00 to 4.16 in.)

Present Position

Sets the label's stop point (Set Form Stop) after printing. This value is independent of the Offset Bias value (Start of Print Position), yet must be greater to have any effect.

*245

Values range:
0 -999

At default this function will have no effect on last label positioning.

0.00 to 9.99 inches.

System options

Allows access to eight system level options.

Factory Settings

Are you sure?

Returns all printer settings to factory defaults, with the exception of Serial Number, Top-of-Form Adjust, Printer Model and Darkness.

Press 'Enter' to reset or \uparrow to abort.

Security Check

*None

Password

Allows user to password protect the advanced setup.

Allows free access to all menu functions.

Must enter correct password for access.

Modify Password

*0123

Allows the user to enter an alphanumeric password.

Use the \leftarrow or \rightarrow keys to scroll for a new value.

Press 'Shift' to move to the next position. Press 'Enter' to accept the new setting.

Internal Module

*0032

Value range:

0 - 1000

Allocates a portion of memory to be used for storing image and label format data.

128 KB reserved as Module A.

Memory is allocated in 4 KB blocks; the reserved space is designated as Module A.

Scaleable Font

*0000

Value range:

0 - 1000

Allocates a portion of memory to be used for loading of scaleable font data.

No reserved font cache.

Memory is allocated in 4 KB blocks. The minimum requirement is 0015 (60 KB); the recommended value is 0025 (100 KB) for Smooth Scaleable Fonts.

Symbol Set

*PC-850 modified

Allows user selection from 29 different scaleable font symbol sets.

Compatibility

Three selections to control label positioning

Offset Bias

*220

110

Selects from two different Start of Print positions. This command sets the point where printing starts, relative to the Top-of-Form Adjust value. The printer will feed from the Offset Bias and the Top-of-Form Adjust value to begin printing.

Positioning

(PE 42 only)

*203 dpi

200 dpi

Allows the selection of the column position calculation based upon one of two different values. Exact column positioning.

Host CMDS-Ignore

This parameter instructs the firmware whether to process the DPL commands for Offset Position (<stx>O), Peel Position (<stx>f), and the Heat value (<stx>l>h)

ProdigyPlus Mode

This function sets the parameters so the printer will emulate a Prodigy Plus printer. These parameters are:

Offset Bias = 110

Positioning = 200DPI

Host Positioning = IGNORE

Conversion = Inches

Peel Position = .25" (1" if cutter is installed)

Operation

Sets three different operational functions.

Pause Mode

Causes the printer to pause between printing each label.

*Disable

Enabled

The 'Pause' button must be pushed in order to print the next label.

Feedback Mode

Causes the printer to feedback ASCII characters 30 and 31.

*Disable

Enable

The printer will return a 30 after each label is printed and a 31 after each batch of labels.

Operation (CONT.)

Test Mode

Causes the printer to send debug characters back to the host. See Appendix E for listings.

*Disable
Enable

Cutter

Controls an external cutter mechanism.

Enable
*Disable

Enables an external cutter.
Cutter not being used.

Ribbon Saver

Controls the optional Ribbon Saver feature.

Enable
*Disable

Enables the option.
Option is not installed or disabled.

Conversion

Sets standard or metric measurement, automatically updating all operations with the new selection.

*Decimal
Metric

Measurements in inches
Measurements in millimeters

Communications

Comm Setup

Allows the user to select communication values for each port.

*PORTA *9600
*8 *N *1 *BOTH

Selects the port and sets parameters.

Selects serial Port A, B or Parallel communication.
Selectable serial baud rates: 300, 600, 1200, 2400, 4800, 9600, 19200.

Sets word length: 7 or 8 bits.

Sets parity bit: E = even, O = odd, N = none.

Sets stop bit length: 1 or 2 bits.

Selects handshaking method: XON/XOFF, CTS/DTR or BOTH.

Control Codes

Sets the DPL control code values.

*Standard Codes
Alternate Codes

01 Hex = SOH command, 02 Hex = STX command
5E Hex = SOH command, 7E Hex = STX command

Maintenance

Selects five different maintenance functions.

Test Print

Each test print function is activated by pressing the ↵ key.

Current Config

Prints labels reflecting the printer's current settings.

Database Config

Prints labels reflecting the menu settings.

Test Ribbon

Prints a series of Ribbon Test Labels.

Test Pattern

Printhead dot pattern test label.

Front Panel

Tests three different Front Panel functions.

LED Test

Toggles the Ribbon/Paper and Pause LED's on the control panel.

Keypad Test

Allows user testing of the six-button menu control pad. The display will indicate the functions of the keys as they are pressed. Pressing twice on the ↑ will exit the test.

Display Test

Cycles alphanumeric characters through each segment of the LCD display.

Test I/O

Tests three different I/O functions.

Monitor GP Input

Active monitor of the General Purpose I/O inputs.

Test GP Output

Tests the General Purpose I/O outputs.

Sensor Readings:

Divided into two sections.

Digital

Indicates the conditions of the printer's digital sensors. The top line contains the sensor input, while the bottom line shows the sensor state. See Table 4-1 for definitions.

Analog

Indicates the converted values of four analog sensors. The top line contains the sensor input, while the bottom line shows a digital representation of the analog value. See Table 4-1 for definitions.

Serial Loopback

Serial Loopback tests the internal transmit, receive and CTS/DTR signals. A special loopback plug must be installed on the port under test (see Figure 4-1). When complete, the printer will respond with the results.

Serial Port A

Tests Port A.

Serial Port B

Tests Port B.

Maintenance (cont.)

Installed Options

Cutter
Ribbon Saver

There are two installed options to choose from:

Modules

Print Directory

Module A
Module B

Modules contain a set of five memory function routines. Some of these memory tests are destructive, in this case, the printer will prompt “Are you sure?” before beginning.

Prints a list of all files (fonts, images and labels), stored on the selected module.

Module A is the printer's internal memory allocation. Module B refers to an external Flash, if equipped.

Print File

Print File on
Module A
Print File on
Module B

Prints a file from a selected module.

Prints from Module A; specify file type and then file name. The printer will then print the contents.

Same function as Module A, but prints the specified contents of the external module file.

Copy Module

Copy From
Module A
Copy From
Module B

Copies data from one module to another.

Copies from Module A to Module B.

Copies from Module B to Module A.

Format Module

Format Module A
Format Module B

Formats a selected memory module.

Caution! Formatting permanently erases data!

Formats Module A. Printer will prompt, “Are You Sure?” All data will be lost.

Same as Module A. The Write Protect Switch must be turned ‘Off’ to format this module.

Test Module

Test Module A
Test Module B

Tests the selected memory module by writing to, reading from and then verifying the data for accuracy.

Caution! Testing permanently erases data!

Tests Module A. The printer will prompt, “Are You Sure?” All data will be lost.

Same as Module A. The Write Protect Switch must be turned ‘Off’ to test this module.

Inputs	Sensor Name	Possible Condition
HD	Head	D = Down, U = Up
CT	Cutter	D = Down, U = Up
SP	Present Sensors	Y = Blocked, N = Not Blocked
RS	Ribbon Saver	D = Down, U = Up
RM	Ribbon Motion	1 = Blocked, 0 = Not Blocked
THR	Thermistor	0-255
REF	Reflective	0-255
TRAN	Transmissive	0-255
PO	Paper Out	0-255

Table 4-1 Sensor Definitions

RS-232c Test Plug (DB-25P)

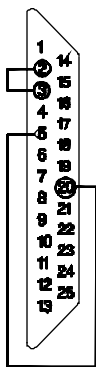

RS-422 Test Plug (DB-25P)

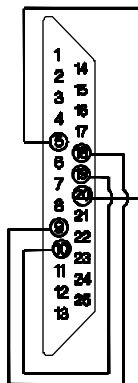

Figure 4-2 Serial Loopback Test Plug Connections



PRINTER ADJUSTMENTS

5.0 Introduction

When changing label size or material it may be necessary to adjust certain printer components and label settings. This chapter provides step-by-step instructions for completing these adjustments. If there is any doubt about your ability to perform these procedures, contact a qualified service technician, a technical support representative or software representative.

5.1 Media Sensor Adjustment

To detect the label's edge, notch or black stripe, the printer uses a label edge sensor that is adjustable across half the media path. The position of this sensor may need to be adjusted when changing types of labels or when going from wide to narrow labels.

Referring back to Figure 2-3, locate the Edge Sensor Adjustment Knob on the printer. This will adjust the sensor position across the label. If you are experiencing a problem with the label top of form, try adjusting this sensor. If using labels that are die-cut or that have a black stripe across the back, position the sensor near the middle of the label. If using labels that have a notch, irregular edge or with a black stripe that does not cover the entire width of the label, turn the adjustment knob in half turn increments until the label is sensed. See Section 7 for more information.

5.2 Media Width Adjustment

The printer is able to use a wide variety of media types, widths and thickness. The printhead mechanism has a feature that allows the user to make a leveling adjustment. This adjustment is required when using labels that are less than 4" wide.

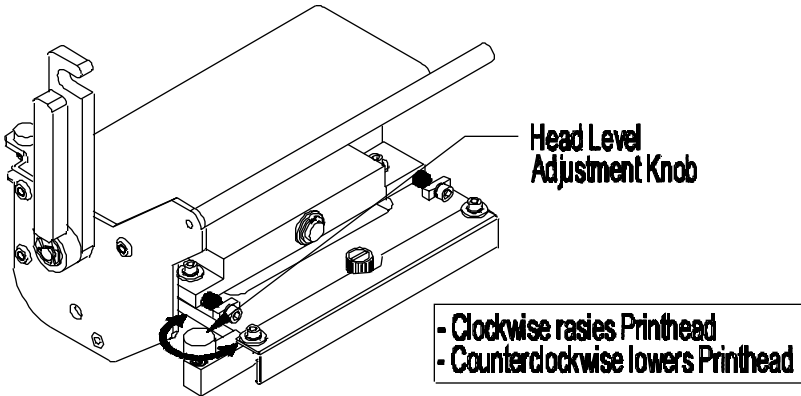
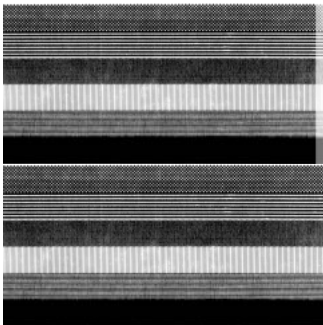

Figure 5-1 Adjusting Media Width

Load the Printer with the chosen media. Begin printing your label format. Rotate the Head Level Adjustment Knob, (see Figure 5-1) clockwise until the print quality along edge starts to lighten. Finally, rotate the knob back just enough to achieve uniform print quality across the label, see below.



Print beginning to lighten.

Proper final adjustment.

Figure 5-2 Example of the Media Width Adjustment

Note: Labeling program settings can override many of the functions available through the printer's menu.

5.3 Label Start of Print

Start of print position can be affected by the position of the label edge sensor, especially if the labels are irregularly shaped. Once properly positioned, the start of print position can be adjusted by using the <STX>O command or through your labeling program. Also, the TOF Adjust provides additional printer specific adjustment and can be found in the Basic Function Menu.

5.4 Label Presentation

Following the printing of a label, the printer will position the label according to its programmed Present Distance. The value will be dependent upon the needs of the applicator system. The Present Distance value can be input using the <STX> f system level command, through Label Options in the Advanced Setup Menu or through your labeling program.

5.5 Setting Start of Print and Peel Position

Every effort has been made to make the default parameters work for your application right out of the box. Due to the vast number of software packages, applicators, and label formats this is not always the case. The following steps may help your setup of the printer.

Step	Description
1	<p>Disable the Host Positioning parameters. Set COMPATABILITY/HOST POSITIONING to IGNORE. This ensures that after setup the host label software cannot override the printer.</p>
2	<p>Concentrate on getting any printed fields aligned on your label media.</p> <ol style="list-style-type: none">(Only required on Right Handed printer models). Select the LABEL OPTIONS/LABEL WIDTH to the proper value. A value larger is better than smaller.(Up/Down Adjustment). Modify the BASIC FUNCTION/START of PRINT parameter until print is horizontally aligned.(Left/Right Adjustment). Modify the BASIC FUNCTION/COLUMN ADJUST until print is vertically aligned. <p>The label should be printing in the correct locations.</p>
3	<p>Adjusting the correct Peel Position using the LABEL OPTIONS/PEEL POSITION parameter.</p> <p>This parameter is measured relative the COMPATABILITY/OFFSET BIAS selection. If the Offset Bias is set to 220 (default) then setting the Peel Position to 245 will extend the peel position an additional .25 inches. A value of 320 would be an additional 1 inch.</p>

5.6 Controlling Print Quality

The printer provides maximum flexibility by offering both direct thermal and thermal transfer printing capabilities. To support these printing options, the printer has a flexible set of printing controls.

The amount of heat applied by the printhead and the location of the printhead in relation to the label media have the most effect on the images that are printed on the labels. The printer provides adjustments for quality, but limits them to prevent possible damage to the printer. For example, low cost direct thermal stocks have very high reaction temperatures, therefore it takes a great deal of energy to make clear images on this type of media. This is also true for some thermal transfer materials, (see Appendix F; Media and Ribbon Overview). The printer provides three ways to compensate for this:

Increase the darkness setting in the Basic Functions Menu (this will give only slight adjustment).

Use the H label formatting command to increase the software heat setting for a specific format, use the Heat Setting option in the Advanced Setup Menu for all formats or make adjustments through your labeling program.

Use the P label formatting command to adjust the print speed for a specific format, use the Print Speed option in the Advanced Setup Menu for all formats or make adjustments through your labeling program.



MAINTENANCE

6.0 Introduction

The chapter covers the cleaning recommendations for your printer. The following items will help clean your printer safely and effectively.

- Isopropyl alcohol
- Cotton swabs
- Clean, soft and lint-free cloth
- Soft-bristle brush or compressed air
- Mild detergent



CAUTION

For your safety and to avoid damaging the Printer, always power off and unplug the unit before cleaning.

Interior and Exterior Cleaning

Interior During normal operation, dust particles from the label stock accumulate inside the printer. These particles can begin to foul the print. To prevent build-up, use a soft-bristle brush or compressed air as needed for removal.

Exterior The exterior can be cleaned using a general purpose cleaner and a damp soft-cloth or sponge. Do not use abrasive cleansers or solvents.

6.1 Cleaning Schedule

The following table provides a recommended cleaning schedule for various parts of your printer.

 CAUTION	For your safety and to avoid damaging the Printer, always power off and unplug the unit before cleaning.
---	--

Area	Method	Interval
Printhead	Using isopropyl alcohol and a cotton swab, clean the printhead from end to end. Removing all adhesive and dirt.	Clean after each roll of ribbon or each roll of direct-thermal labels.
Platen Roller	Rotate the platen, cleaning it thoroughly using isopropyl alcohol on a cotton swab or lint-free cloth.	Clean after each roll of ribbon or each roll of direct-thermal labels.
Media Path	Compressed air / soft-bristle brush and isopropyl alcohol.	As needed, based on weekly visual inspection.
Peel/Tear Bar	Isopropyl alcohol	As needed, based on weekly visual inspection.
Media Sensor	Compressed air, isopropyl alcohol if needed.	Monthly or as needed.
Interior	Soft-brush or compressed air.	As needed.
Exterior	Mild detergent.	As needed.

Table 6-1 Printer Cleaning Schedule

6.2 Cleaning the Printhead

When print quality begins to degrade the typical cause is a dirty printhead. Unreadable barcodes, print drop-out areas, streaking and smudging are all possible symptoms. In addition, if this build-up is left on the printhead it will greatly reduce it's life. Follow this simple procedure to clean the printhead:

- ❶ Turn 'Off' and unplug the printer.
- ❷ Open the cover. Raise the Head-Lift Lever 'up' to access the printhead. Move ribbon or paper away as necessary.
- ❸ Gently wipe the underside of the printhead clean using a cotton swab moistened (not soaked) with isopropyl alcohol. Allow to dry.
- ❹ Re-install ribbon and media, if necessary. Lower the printhead by turning the Head-Lift Lever 'down' until it locks into position.
- ❺ Close the cover. Plug in and turn 'On' the printer. Feed several labels to normalize label tracking.

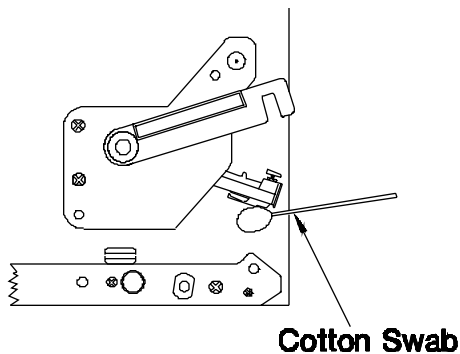

Figure 6-1 Cleaning the Printhead

Note: NEVER use a sharp object when cleaning the printhead.

6.3 Cleaning the Platen Roller

Print quality may be affected if the platen becomes contaminated with grit, label adhesive, or ink. To clean the platen:

- ❶ Turn 'Off' and unplug the printer.
- ❷ Open the cover. Raise the Head-Lift Lever 'up' to access the printhead. Move ribbon or paper away as necessary.
- ❸ Using a clean lint-free cloth dampened with isopropyl alcohol wipe off any debris from the platen. Manually rotate the roller, cleaning the entire surface. Allow to dry.
- ❹ Re-install ribbon and media, if necessary.
- ❺ Lower the printhead by turning the Head-Lift Lever 'down' until it locks into position.
- ❻ Close the cover. Plug in and turn 'On' the printer. Feed several labels to normalize tracking.

<p>☑ Note: If the platen has excessive build-up that cannot be removed with isopropyl alcohol, you may use acetone sparingly. NEVER use a sharp object when cleaning the platen roller.</p>
--



TROUBLESHOOTING

7.0 Introduction

Occasionally, situations occur that require some troubleshooting skills. Possible problem situations and potential solutions are listed in this section. While not every situation is addressed, you may find some of these tips helpful. If you do not feel comfortable performing the action or for problems that may persist or that have not been covered in this section, contact a Technical Support Representative.

7.1 Troubleshooting Tips

The Printer fails to power up (no lights):

Verify that the AC power connection has been made at both the wall and the printer and the power switch is turned 'on'.

Verify that the AC power outlet being used is operating correctly. Test the outlet by connecting another device to it.

The AC power cord may be damaged; replace.

The Printer's power switch may be defective or the fuse may be blown; call for service.

No display (the Power LED is on):

The display contrast may be set too low. Using a small screwdriver use the access opening on the front panel and increase the setting.

The printer may have a bad connection to the display or the display may be faulty; call for service.

Black boxes in display:

The printer has failed to initialize. Power the printer 'Off'. Hold down the Pause, Feed and Stop/Cancel buttons while powering the printer 'On'.

Defective display/main PCB; call for service.

Skips Labels (every other):

The label is formatted too close to the top edge of the label. Try reformatting, allowing a larger margin near the label's edge.

No Print (paper advances but without printing an image):

If an image appears on the used ribbon but not on the label, the incorrect ribbon type (emulsion out) is being used. Consult Appendix F for additional information or contact a Media Representative.

The media and ribbon combination may be incorrect. Consult Appendix F for additional information or contact a Media Representative.

The heat setting may be too low. Make an adjustment through your software program or through the Advanced Setup Menu.

No Print (cont.):

Perform a Self-Test. If the labels printed correctly, check the label format and communication parameters, (see Section 7.3).

Printhead or print control circuitry may be defective, call for service.

Poor Print Quality:

The printhead may be dirty. Refer to Section 6 for cleaning instructions.

Check that the Print Method setting in the Basic Function Menu is correct for the media type being used.

The Heat Setting may be too high or too low. Try adjusting the setting through your labeling program or through the Advanced Setup Menu. Also the Darkness setting may need adjusting.

The media and ribbon combination may be incorrect. Consult Appendix F for additional information or contact a Media Representative.

The Media Width Adjustment may need to be performed, (see Section 5).

The platen may be dirty or worn, see Section 6.

The Printhead may need adjusting; call for service.

Erratic Printing (prints strange characters instead of the format):

The printer may be in the Character Dump Mode. Power the Printer 'Off and On' and retry.

Verify all the communications parameters have been correctly set to match the host. See Section 7.2 for details.

Missing Data in the printed label:

Check the label format, (see Section 7.3). Verify that the proper syntax was used for the desired function and that the data fields are properly defined. For rotated fields, ensure that enough label space exists in that orientation to apply the format.

Ensure that enough memory space is available for the label format size, graphic image and/or scaleable font.

7.2 Error Messages

The printer's control electronics monitors various operations. If a problem is detected, an error message will be displayed. The following is a list of error messages with some possible causes and solutions.

During power up the following alarms could be displayed:

LCD Display

Alarm Description

PROM FAULT

The system detected a PROM failure.

Call for service.

RAM FAULT

The system detected a RAM failure.

Call for service.

RTC RAM FAULT

The system detected a real-time clock RAM failure.

Try to clear the fault by cycling the printer off and on again. If it does not clear, call for service.

Other messages that could appear during operation are:

LCD Display

Alarm Description

ADC FAULT

The system detected an Analog-to-Digital Converter failure.

Try to clear the fault by cycling the printer off and on again. If it does not clear, call for service.

APPLICATOR BUSY

System is waiting for control of the Print Cycle from the applicator.

Printer applicator enable control may be incorrectly configured. Verify setup; see Section 4, Advanced Setup/PE Options/PE Apply HW.

Possible defective applicator output control.

Possible defective printer applicator port.

COVER OPEN FAULT
T

The cover interlock switch is open.

Verify that the cover has been closed completely.

Interlock switch may be defective or out of adjustment; call for service.

HEAD UP FAULT

The printhead interlock switch is open.

Verify that the printhead Head-Lift Lever has been locked down completely into the stand-off.

Interlock switch may be defective or out of adjustment; call for service.

No Modules Available

The printer could not find a valid module; possible causes:

No module is installed or configured.

Write Protect switch is 'On'.

The module is corrupted. Cycle the printer off and on. This will reformat an internal module. Use Advanced Setup/Modules in the Menu to test the module.

A hardware problem exists; call for service.

OUT OF STOCK

The printer's Label Edge Sensor does not detect labels.

Ensure the labels are properly fed through the Label Edge Sensor.

Loose connection or possible defective sensor; call for service.

PRINTHEAD FLT

The system has detected a printhead control circuit failure; call for service.

RIBBON FAULT

The system has detected a fault in ribbon motion.

The ribbon may be incorrectly installed or the wrong type for the printer (emulsion out), verify that the dull side (in most cases) is facing the label.

An incorrect media and ribbon combination may be resulting in an insufficient amount of friction between the media and ribbon. See Appendix F for additional information or contact a Media Representative.

The ribbon core may be too large. Ensure that the ribbon supply core fits snugly on the Ribbon Supply Hub.

The printer may be set to “Transfer” but is using direct thermal labels.

Defective or dirty ribbon sensor; call for service.

RIB SAVER FAULT

The ribbon saver operation failed.

Disable the option through the Menu. Reset the printer.

Call for service.

RIBSVR NotEQP

The Ribbon Saver Option is enabled but not installed.

Disable the option through the menu and/or your labeling program. Reset the printer.

TOF FAULT

The printer's Edge Sensor cannot see a gap or notch in the label stock.

Examine the Label Edge Sensor for obstructions (for example, labels stuck to the sensor or dust blocking the sensor).

Label Edge Sensor may be out of position for the size or type of media being used. Re-adjust the position.

The wrong type of Sensor TOF has been chosen. Re-configure the printer for the label type being used.

Possible defective Label Edge Sensor; call for service.

Listen for drive motor operation and verify that the platen roller is turning. If not, call for service.

7.3 Character Dump Mode

The character dump mode is a useful tool for diagnosing various printer problems, communication problems, or DPL syntax errors. This procedure allows the user to input strings of data and compare them with the output from the printer. In many cases, the Programmer's Manual is an essential reference. Also, as a final note, many of the software programs use bit mapping to construct the label, making a diagnosis difficult. Always contact a Technical Support Representative with any questions.

With the printer 'Off', print a Configuration Label using the power-up method:

- ❶ Press and hold in the Feed button while turning the printer 'On'.
- ❷ Release the Feed button when the printer display reads 'DYNAMIC RAM DIAGNOSTICS'...
- ❸ The printer will print a set of Configuration Labels and then enter the Character Dump Mode.

Figure 7-1 shows a sample Character Dump Label. Send a label format to the printer. The hex code output will be immediate. This output can be used for debugging the label format. Also by repeatedly sending the format, this mode can uncover handshaking problems (if they exist). Handshaking problems are identified by sections of missing data in the character string.

```

0000 02 4C 00 44 31 31 00 31 ^L 011.1
0008 36 31 31 30 30 30 30 33 61100003
0010 32 30 30 30 31 30 46 4F 200010F0
0018 4E 54 20 36 3A 20 41 4C NT 6: AL
0020 4C 20 56 41 4C 49 44 20 L VALID
0028 20 20 20 20 20 20 20 20
0030 20 20 20 00 31 36 31 31 1611
0038 30 30 30 30 32 33 30 30 00002800
0040 30 31 30 20 20 20 20 20 010
0048 20 20 20 43 48 41 52 41 CHARA
0050 43 54 45 52 53 3A 00 31 CTERS: .1
0058 36 31 31 30 30 30 30 32 61100002
0060 34 30 30 30 31 30 23 24 400010#$
0068 25 26 28 29 2A 2B 2E 20 %&()*+,-

```

Figure 7-1 ASCII Character Dump Label

☑ **Note:** To exit the Character Dump Mode, reset the printer by turning it 'off' and then 'on'.



Appendix A

ASCII Control Chart

Char	Dec	Hex	Char	Dec	Hex	Char	Dec	Hex	Char	Dec	Hex
NUL	0	00		32	20	@	64	40	`	96	60
SOH	1	01	!	33	21	A	65	41	a	97	61
STX	2	02	"	34	22	B	66	42	b	98	62
EXT	3	03	#	35	23	C	67	43	c	99	63
EOT	4	04	\$	36	24	D	68	44	d	100	64
ENQ	5	05	%	37	25	E	69	45	e	101	65
ACK	6	06	&	38	26	F	70	46	f	102	66
BEL	7	07	>	39	27	G	71	47	g	103	67
BS	8	08	(40	28	H	72	48	h	104	68
HT	9	09)	41	29	I	73	49	i	105	69
LF	10	0A	*	42	2A	J	74	4A	j	106	6A
VT	11	0B	+	43	2B	K	75	4B	k	107	6B
FF	12	0C	,	44	2C	L	76	4C	l	108	6C
CR	13	0D	-	45	2D	M	77	4D	m	109	6D
SO	14	0E	.	46	2E	N	78	4E	n	110	6E
SI	15	0F	/	47	2F	O	79	4F	o	111	6F
DLE	16	10	0	48	30	P	80	50	p	112	70
DC1	17	11	1	49	31	Q	81	51	q	113	71
DC2	18	12	2	50	32	R	82	52	r	114	72
DC3	19	13	3	51	33	S	83	53	s	115	73
DC4	20	14	4	52	34	T	84	54	t	116	74
NAK	21	15	5	53	35	U	85	55	u	117	75
SYN	22	16	6	54	36	V	86	56	v	118	76
ETB	23	17	7	55	37	W	87	57	w	119	77
CAN	24	18	8	56	38	X	88	58	x	120	78
EM	25	19	9	57	39	Y	89	59	y	121	79
SUB	26	1A	:	58	3A	Z	90	5A	z	122	7A
ESC	27	1B	;	59	3B	[91	5B	{	123	7B
FS	28	1C	<	60	3C	\	92	5C		124	7C
GS	29	1D	=	61	3D]	93	5D	}	125	7D
RS	30	1E	>	62	3E	^	94	5E	~	126	7E
US	31	1F	?	63	3F	_	95	5F		127	7F

Char	Dec	Hex	Char	Dec	Hex	Char	Dec	Hex	Char	Dec	Hex
Ç	128	80	á	160	A0		192	C0	Ó	224	E0
ü	129	81	í	161	A1		193	C1	ß	225	E1
é	130	82	ó	162	A2		194	C2	Ô	226	E2
â	131	83	ú	163	A3		195	C3	Õ	227	E3
ä	132	84	ñ	164	A4		196	C4	ö	228	E4
à	133	85	Ñ	165	A5		197	C5	Õ	229	E5
â	134	86	ª	166	A6	ã	198	C6	µ	230	E6
ç	135	87	º	167	A7	Ã	199	C7	þ	231	E7
ê	136	88	¿	168	A8		200	C8	þ	232	E8
ë	137	89	®	169	A9		201	C9	Ú	233	E9
è	138	8A		170	AA		202	CA	Û	234	EA
ï	139	8B	1/2	171	AB		203	CB	Ü	235	EB
î	140	8C	1/4	172	AC		204	CC	ý	236	EC
ì	141	8D	ì	173	AD		205	CD	Ý	237	ED
Ã	142	8E		174	AE		206	CE		238	EE
Å	143	8F		175	AF		207	CF		239	EF
É	144	90		176	B0	ð	208	D0		240	F0
æ	145	91		177	B1	Ð	209	D1	±	241	F1
Æ	146	92		178	B2	Ê	210	D2		242	F2
ô	147	93		179	B3	Ë	211	D3	3/4	243	F3
ö	148	94		180	B4	Ë	212	D4		244	F4
ò	149	95	Á	181	B5		213	D5		245	F5
û	150	96	Â	182	B6	Í	214	D6	÷	246	F6
ù	151	97	À	183	B7	Î	215	D7	,	247	F7
ÿ	152	98	©	184	B8	Ï	216	D8	°	248	F8
Ö	153	99	¹	185	B9		217	D9	¨	249	F9
Û	154	9A		186	BA		218	DA	·	250	FA
ø	155	9B		187	BB		219	DB		251	FB
£	156	9C		188	BC		220	DC		252	FC
Ø	157	9D	¢	189	BD		221	DD		253	FD
x	158	9E	¥	190	BE	ì	222	DE		254	FE
f	159	9F		191	BF		223	DF		255	FF

The printable characters shown are from the Font 9, internal CG Triumvirate symbol set.

Note: For the software handshake XON/XOFF commands:
XON = (DC1), XOFF = (DC3)



Appendix B

Available Fonts and Barcodes

All character fonts and bar codes available with the Printer are described in this section. Each font and barcode have a name associated with it for use in programming. Human-readable fonts have numeric names while bar code fonts have alpha names. Uppercase alpha names will print bar codes with human-readable interpretations, while lowercase alpha names will print bar codes only.

Fonts 0 through 8 use the slash zero (Ø) conventions for distinguishing between the zero and the letter O. The slash can be removed with the label formatting command Z. These fonts are non-proportional (monospaced) fonts, all of the characters take up the same amount of space when printed. This is helpful when using variable data in a fixed area. The sizes of these fonts are shown in Table B-1.

The Triumvirate font number 9 is a proportional font, each character will take up a different amount of space when printed. For example, the letter W will be larger than the letter I.

Listed below are a few of the 29 scaleable font symbol sets that are accessible:

- (US) ISO 6: ASCII Symbol Set, font code S00
- (DN) ISO 60 Danish/Norwegian Symbol Set, font code S00
- (IT) ISO 15: Italian Symbol Set, font code S00
- (GR) ISO 21: German Symbol Set, font code S00
- (FR) ISO 69: French Symbol Set, font code S00
- (E5) ISO 8859/5 Latin 5 Set, font code S00
- (E2) ISO 8859/2 Latin 2 Set, font code S00
- (DT) DeskTop Symbol Set, font code S00

For a complete list of the scaleable font symbol sets refer to the Programmer's Manual.

Human-Readable Fonts

Font Matrix Sizes				Charac. Per Inch
Font	Dot Height	Dot Width	Dot Spacing	203 DPI
0	7	5	1	33.83
1	13	7	2	22.56
2	18	10	2	16.92
3	27	14	2	12.69
4	36	18	3	9.67
5	52	18	3	9.67
6	64	32	4	5.64
7	32	15	5	10.15
8	28	15	5	10.15

Table B-1 Human-Readable Font Sizes

Font	Valid ASCII Characters, Decimal
0	32-126
1	32-168, 171, 172, 225
2	32-168, 171, 172, 225
3	32, 35-38, 40-58, 65-90, 128, 142-144, 146, 153, 154, 156, 157, 165, 168, 225
4	32, 35-38, 40-58, 65-90, 128, 142-144, 146, 153, 154, 156, 157, 165, 168, 225
5	32, 35-38, 40-58, 65-90, 128, 142-144, 146, 153, 154, 156, 157, 165, 168, 225
6	32, 35-38, 40-58, 65-90, 128, 142-144, 146, 153, 154, 156, 157, 165, 168, 225
7	32-126
8	32, 48-57, 60, 62, 67, 69, 78, 83, 84, 88, 90
9	32-126, 128-169, 171-173, 181-184, 189, 190, 198, 199, 208-216, 222, 224-237, 241, 243, 246-250

Table B-2 Valid Human-Readable Font ASCII Characters

0 - Identifies a 96-character alphanumeric font.

```
Font 0:
!"#$%&'()*+,-./0123456789:;<=>?@
ABCDEFGHIJKLMNOPQRSTUVWXYZ[\]^_`
abcdefghijklmnopqrstuvwxyz{|}~
ÇüéàààààçèèèèèïïïïïÀÁÂÃÄÅ
äåæçèéëêëìíîïñÑñòóôõö÷øù
```

1 - Identifies a 145-character uppercase and lowercase alphanumeric font that includes descenders and ascenders.

```
Font 1:
!"#$%&'()*+,-./0123456789:;<=>?@
ABCDEFGHIJKLMNOPQRSTUVWXYZ[\]^_`
abcdefghijklmnopqrstuvwxyz{|}~
ÇüéàààààçèèèèèïïïïïÀÁÂÃÄÅ
äåæçèéëêëìíîïñÑñòóôõö÷øù
```

2 - Identifies a 138-character alphanumeric upper and lowercase font.

```
Font 2:
!"#$%&'()*+,-./0123456789:;<=>?@
ABCDEFGHIJKLMNOPQRSTUVWXYZ[\]^_`
abcdefghijklmnopqrstuvwxyz{|}~
ÇüéàààààçèèèèèïïïïïÀÁÂÃÄÅ
äåæçèéëêëìíîïñÑñòóôõö÷øù
```

3 - Identifies a 62-character alphanumeric uppercase font.

```
FONT 3:
!"#$%&'()*+,-./0123456789:
ABCDEFGHIJKLMNOPQRSTUVWXYZ
ÇÁÂÉÖÜ£ØÑ¿ß
```

4 - Identifies a 62-character alphanumeric uppercase font.

```
FONT 4:
!"#$%&'()*+,-./0123456789:
ABCDEFGHIJKLMNOPQRSTUVWXYZ
ÇÁÂÉÖÜ£ØÑ¿ß
```

5 - Identifies a 62-character alphanumeric upper case font.

```
FONT 5:
!"#$%&'()*+,-./0123456769:
ABCDEFGHIJKLMNOPQRSTUVWXYZ
ÇÁÂÉÖÜ£ØÑ¿ß
```

6 - Identifies a 62-character alphanumeric uppercase font.

FONT 6:
\$ % & () * + . - . /
0 1 2 3 4 5 6 7 8 9 :
A B C D E F G H I J K L
M N O P Q R S T U V W X Y Z
Ç Å Ä Ö Ù £ Ø Ñ ¿ ß

7 - Identifies a font that prints OCR-A, size I.

Font 7:
! " # \$ % & ' () * + , - . /
0 1 2 3 4 5 6 7 8 9 : ; < = > ? @
A B C D E F G H I J K L M N O
P Q R S T U V W X Y Z [\] ^ _ `
a b c d e f g h i j k l m n o
p q r s t u v w x y z { | } ~

8 - Identifies a font that prints OCR-B, size III.

Font 8:
0 1 2 3 4 5 6 7 8 9
< > C E N S T X Z I

9 - Identifies the internal Triumvirate font.

6 pt ABCDEFGHIJKLMNOPQRSTUVWXYZabcdefghijklmnopqrstuvwxyz0123456789
8 pt ABCDEFGHIJKLMNOPQRSTUVWXYZabcdefghijklmnopqrstuvwxyz
10 pt ABCDEFGHIJKLMNOPQRSTUVWXYZabcdefghijklmnopqrstuvwxyz
12 pt ABCDEFGHIJKLMNOPQRSTUVWXYZabc
14 pt ABCDEFGHIJKLMNOPQRSTUVWXYZ
18 pt ABCDEFGHIJKLMNOPQR
24 pt ABCDEFGHIJKLM
30 pt ABCDEFGHIJ
36 pt ABCDEFG
48 pt ABCD

Barcode Fonts

Font	Bar Code	Length	Cksum	Valid Characters
A	Code 3 of 9	Varies	No	0-9, A-Z, -. *\$/+% and space char.
B	UPC-A	11 digits	Yes	0-9
C	UPC-E	6 digits	Yes	0-9
D	Interleaved 2 of 5	Varies	No	0-9
E	Code 128 (A,B,C)	Varies	M-103	entire 128 ASCII character set.
F	EAN-13	12 digits	Yes	0-9
G	EAN-8	7 digits	Yes	0-9
H	Health Industry Bar Code (HIBC)	Varies	M-43	0-9, A-Z, -\$/:. The Host must supply leading "+"s
I	Codabar	Varies (Min. 3)	No	0-9, -, ., \$, :, /, +, and the start/stop codes: a, b, c, and d.
J	Interleaved 2 of 5 with modulo 10 checksum	Varies	M-10	0-9
K	Plessey	Varies	M-10	0-9. Option + is last character for second M-11 checksum
L	Interleaved 2 of 5 with modulo 10 checksum & shipping bearer bars	13	M-10	0-9
M	UPC 2 digit add.	2 digits	Yes	0-9
N	UPC 5 digit add.	5 digits	Yes	0-9
O	Code 93	Varies	No	All 128 ASCII characters
p	Postnet	Varies	Yes	0-9
Q	UCC/EAN Code 128	19 digits	Yes	0-9
R	UCC/EAN Code 128 K-MART NON EDI	18 digits	Yes	0-9
S	UCC/EAN Code 128 Random Weight	Varies. At least 34 digits	Yes	0-9
T	Telepen	Varies	Yes	All 128 ASCII characters
u	UPS MaxiCode	84	Yes	0-9, A-Z
v	FIM	1 char.	No	A, B, C, or D
z	PDF-417	Varies	Yes	All ASCII characters

Table B-3 Valid Bar Code Font ASCII Characters



0123456789

Barcode A



0 12345 67890 5

Barcode B

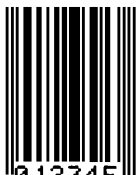

0 0 12345 7

Barcode C



0123456790

Barcode D



01234567890

Barcode E



0 123456 7890 12

Barcode F



0 123 4565

Barcode G



+012345678900

Barcode H



01234567890

Barcode I



012345678905

Barcode J



01234567890

Barcode K

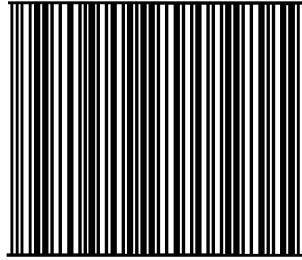

0 12 34567 89012 0

Barcode L



Barcode M

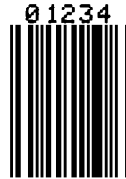

Barcode N



42

Barcode O



Barcode P

(01) 2 3456789 012345678 9

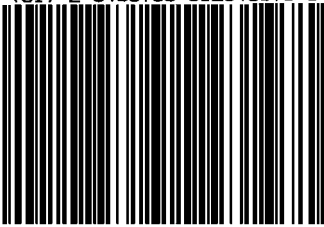

Barcode Q

34 567890 123 4567



Barcode R

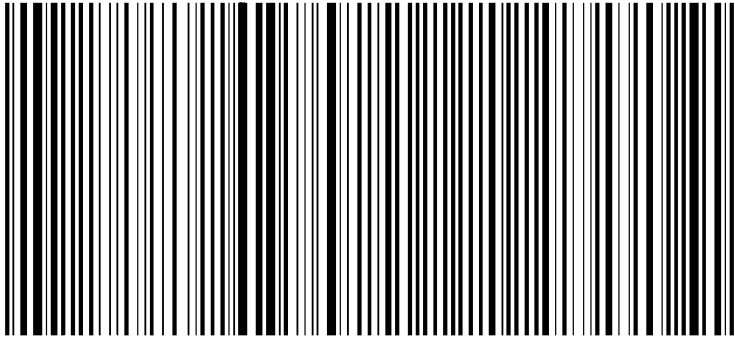

01 10073675029260 11 930420 3202 001800 21 10123456

Barcode S

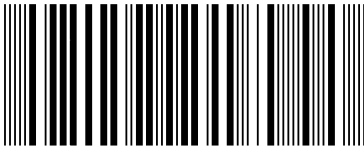

ABCDEF

Barcode T

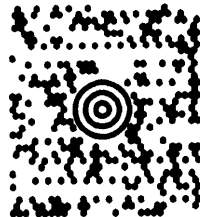

Barcode u



Barcode v



Barcode z



Appendix C

Cable Listing

When a serial interface between the Printer and host is used, a serial cable meeting specific pin assignments is required. Configurations for typical interfaces are shown below, (contact your distributor for ordering information). The parallel interface connection can be made using a Centronics® parallel interface cable.

Null Modem or Straight Cable (MXM)

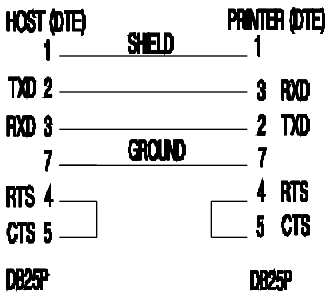

“PC” (DB25P) to Printer

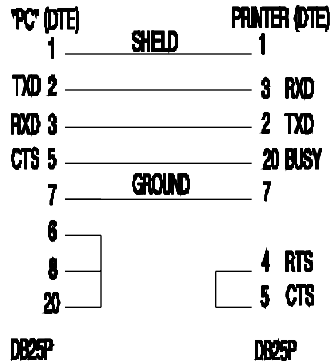

“PC” (DB9P) to Printer

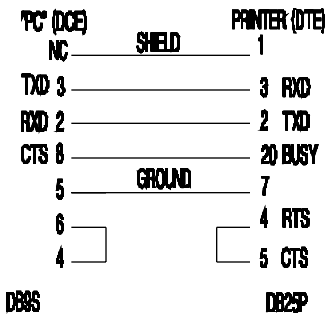

RS-422 Connection

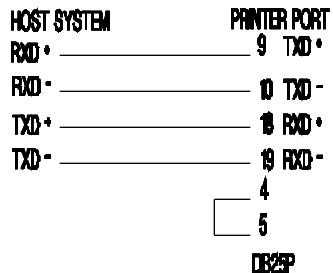

Table C-1 Serial Cable Requirements



Appendix D

Applicator Port Test Box

The Applicator Port can be tested and monitored with a simple test circuit. The schematic for this test circuit is shown below. Be sure to enable the Applicator Port through the Front Panel Menu to permit the use of SW 1.

SW 1 can be a normally open, momentary, or combination of both.

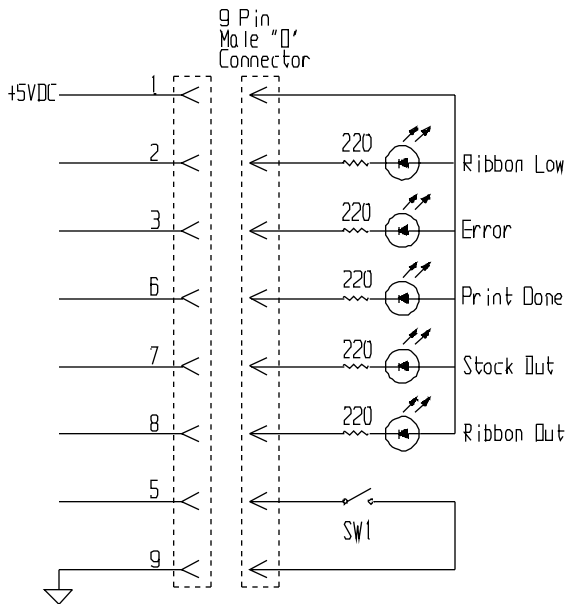

Figure D-1 Applicator Port Test Circuit



Appendix E

Error Codes

The most common error codes transmitted by the Printer are described below.

- | | |
|-----------------------|--|
| Lower case “c” | Printer received a data byte from the host that contains a framing error (corrupted) due to noise. |
| Lower case “e” | Memory module won't clear. Retry after a <STX> W command. |
| Lower case “v” | Input buffer overflow. |
| Upper case “I” | This means that an invalid command sequence was sent to the Printer. The Printer did not understand the command sequence and terminated the command interpreter. |
| Upper case “R” | This code will be sent every time the Printer is turned on, this means there was a hardware reset. |
| Upper case “T” | This means that the Printer has had a watchdog time-out condition. This is how a software reset occurs. A software reset is made by sending the command sequence to the Printer or by doing a front panel reset. |
| BELL HEX “07” | This is usually returned on a corrupt image download, or if you try to load an image that is already installed in the module. |



Appendix F

Printer Specifications

Printing

Print Methods	Direct thermal or thermal transfer.
Print Resolution	PE42: 203 dots per inch (8 dots/mm) PE43: 300 dots per inch (12 dots/mm)
Maximum Print Speed	PE42: 10 i.p.s. PE43: 8 i.p.s.
Maximum Print Width	PE42: 4.1 in. (104 mm) PE43: 4.16 in. (105.7 mm)
Maximum Print Length (with standard memory)	PE42: 12 in. (305 mm) PE43: 15 in. (381 mm)
Minimum Print Length	0.25 in. (6.4 mm)

Communications

Protocols	RS-232c, RS-422, RS-485, and Parallel
Speeds	300 to 19,200 baud
Word Length	7-bit or 8-bit
Handshaking	XON/XOFF (receive mode only) and CTS/DTR

Electrical

Power Supply	115/230 VAC, 60/50 Hz, 3.0/1.5A Auto Ranging
Circuit Protection	5 A., 250V fuse

Environmental

Operating Temperature	40°F to 100°F (4°C to 38°C)
Storage Temperature	32°F to 120°F (0°C to 49°C)
Humidity	10% to 95% non-condensing

Physical

Dimensions	H - 11.81 in., W - 9.65 in., D - 15.1 in. (299.7 mm x 245.11 mm x 386.0 mm)
Weight	27 lbs. (12.26 kg)

Media

Width	1.0 in. (25.4 mm) to 5 in.(127 mm)
Length (with standard memory)	PE42: 12 in. (305 mm) PE43: 15 in. (381 mm)
Thickness	0.0025 in. (0.0635 mm) to 0.0100 in. (0.254 mm)
Media Sensing	Transmissive and Reflective
Ribbon Widths and Lengths	On a 1 inch core: 25 mm, 38 mm, 51 mm, 64 mm, 76 mm, 89 mm, 102 mm, 110 mm, 114 mm, in standard 1182 ft. (360m) or 1476 ft. (450m) lengths.

Label Material Thermal-transfer plain-coated papers, vinyl, Mylar, metalized paper, non-woven fabric, fine-woven fabric, thermal-visible light scannable paper, infrared scannable paper, thermal ticket/tag stock, thermally sensitive plastic.

Fonts and Bar Codes

Resident Fonts Nine alphanumeric fonts from .035 in. to .42 in. and OCR-A, OCR-B; CG Triumvirate from AGFA in both portrait and landscape orientations (from 6 to 48 point sizes).

Font Expansion All fonts expandable vertically and horizontally up to 24x. Fonts and Graphics can be printed in four directions: 0°, 90°, 180°, and 270°.

Bar Codes Code 39, Interleaved 2 of 5, Code 128 (subsets A, B, and C), Codabar, LOGMARS, UPC-A, UPC-E, UPC 2 & 5 digit addendums, EAN-8, EAN-13, EAN 2 & 5 digit addendums, UPC random weight, Code 93, Plessey, Universal Shipping Container Symbology, UCC/EAN Code 128, Postnet, PDF 417, Code 128 MOD 43, Telepen, UPS MaxiCode, FIM, Interleaved 2 OF 5 MOD 10 and HIBC.

Printer Dimensions

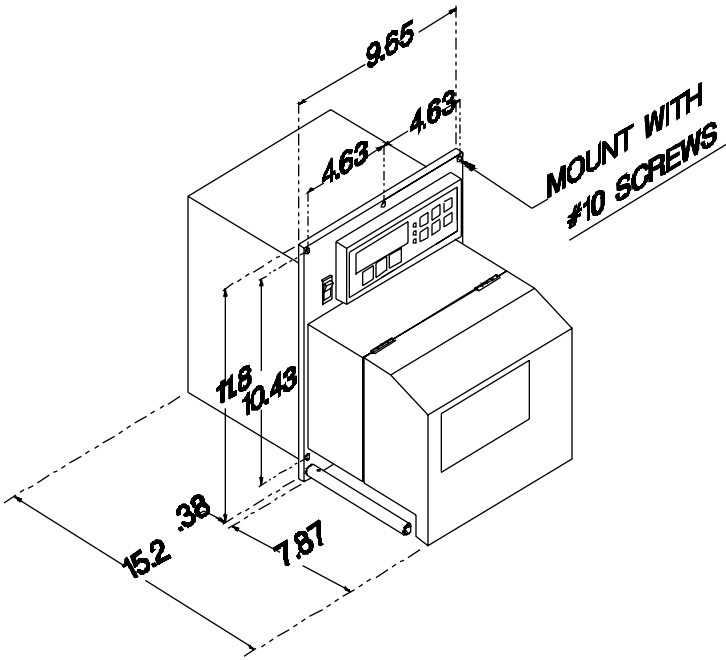

Figure F-1 Print Engine Critical Dimensions.

Media Specifications

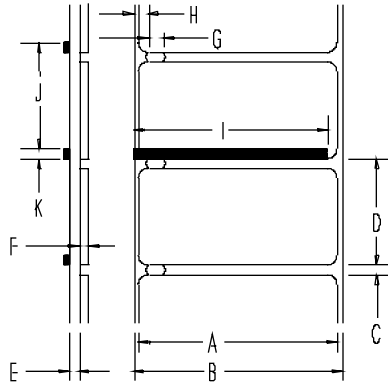

Figure F-2 Acceptable Media Dimensions

	Description	Max. (inches)	Min. (inches)
A	Label width	5.0	1.000
B	Backing width	5.0	1.000
C	Gap between labels	99.99	0.100
D	Label length	99.99	0.500
E	Backing thickness	0.010	0.0025
F	Label thickness	0.010	0.0025
G	Width of sensor opening	0.500	0.170
H	Distance media edge to sensor opening	2.250	0.200
I	Reflective sensor mark width. It is recommended that the entire width of the label is marked.	N/A	1.000
J	Distance between reflective mark	99.99	0.500
K	Reflective sensor mark length	99.99	0.100

Table F-1 Acceptable Media Specifications

Note: The reflective sensor mark must be carbon based ink. The infrared light will not be absorbed by a plain black mark.

Media and Ribbon Basics

Media Selection - Direct Thermal

Consider three important factors when selecting direct thermal stock:

The abrasive qualities of the material that covers the thermal reactive layer of the paper.

The ability of that layer to control the chemical reaction that occurs when the image is “burned”.

The amount of heat required to image the paper.

Media Selection - Thermal Transfer

Consider two important factors when selecting thermal transfer media combinations:

Image quality is affected by the label top coating and ribbon combinations.

Ribbon backcoating is highly recommended. It provides protection for the printhead and many also provide an antistatic coating.

The following table is meant only as a guide. For the correct selection, always consult a qualified Media Representative.

Label Type	Print Speed	Print Energy	Image Durability	Ribbon Type
Coated Paper, Uncoated Paper, Tag Stock, Some Films, Some Synthetics	2 - 10 ips	Low	Low	Wax
Coated Paper, Glossy Paper, Tag Stock, Some Synthetics, Films	2 - 8 ips	Medium	Medium	Wax/Resin
Synthetics Films	4-6 ips	High	High	Resin

Table F-2 Media and Ribbon Overview



Appendix G

Menu Tree

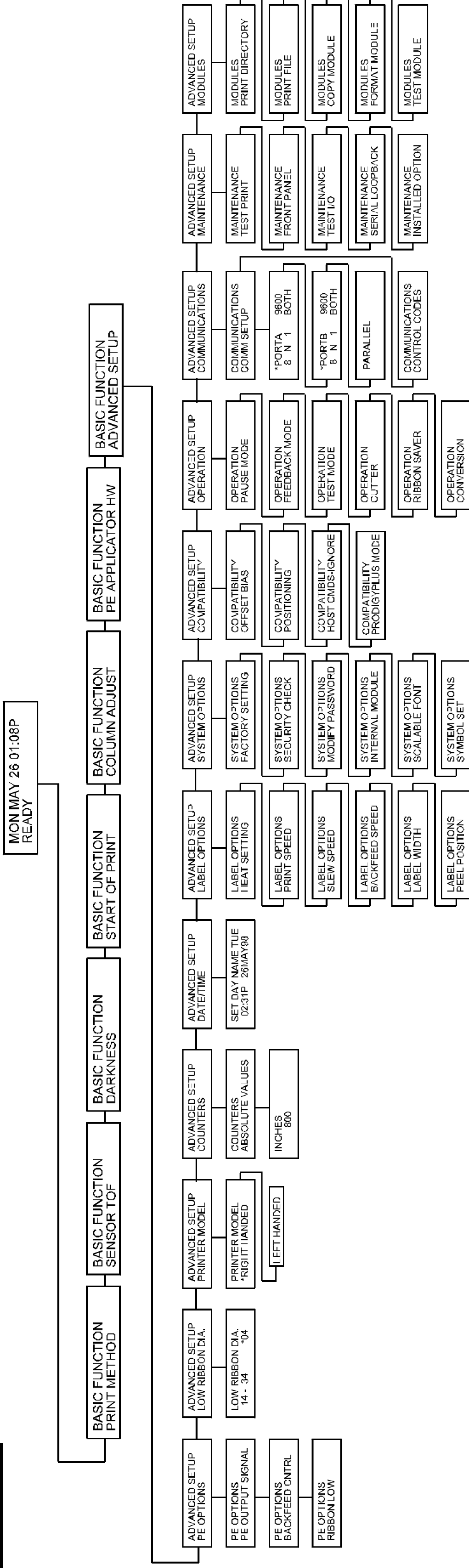



Appendix H

Warranty Information

Datamax Bar Code Products

Limited Warranty Statement

PE42/PE43 Print Engine

Printer

Datamax warrants to Purchaser that under normal use and service, the PE42/PE43 Print Engine, (with the exception of the thermal printhead) purchased hereunder shall be free from defects in material and workmanship for a period of (365) days from the date of shipment by Datamax.

Expendable and/or consumable items or parts such as lamps, fuses, labels and ribbons are not covered under this warranty. This warranty does not cover equipment or parts which have been misused, altered, neglected, handled carelessly, or used for purposes other than those for which they were manufactured. This warranty also does not cover loss, damages resulting from accident, or damages resulting from unauthorized service.

Thermal printhead

This warranty is limited to a period of one year (365 days) or 1,000,000 linear inches of use, whichever comes first, for the PE42/PE43 Print Engine thermal printhead. This one year warranty is valid only if a Datamax - approved thermal or thermal transfer label media is used, as defined in the then current Datamax list of approved Thermal/thermal transfer Media, a copy of which is available from Datamax. Failure to use Datamax approved media is justification for invalidation of this thermal printhead warranty. This warranty does not cover printheads which have been misused, altered, neglected, handled carelessly, or damaged due to improper cleaning or unauthorized repairs.

Warranty Service Procedures

If a defect should occur during the warranty period, the defective unit shall be returned, freight and insurance prepaid, in the original shipping containers, to Datamax at: 4724 Parkway Commerce Blvd., Orlando, Florida 32808. An RMA (Return Material Authorization) number must be issued before the product can be returned. To open an RMA please call Datamax Customer Service Support Department at (407) 523-5550. Please include your RMA number on the outside of the box and on the shipping document. Include a contact name, action desired, a detailed description of the problem(s), and examples when possible with the defective unit. Datamax shall not be responsible for any loss or damages incurred in shipping. Any warranty work to be performed by Datamax shall be subject to Datamax's confirmation that such product meets Datamax warranty. In the event of a defect covered by its warranty, Datamax will return the repaired or replaced product to the Purchaser at Datamax's cost.

With respect to a defect in Hardware covered by the warranty, the warranty shall continue in effect until the end of the original warranty period, or for sixty (60) days after the repair or replacement, whichever is later.

General Warranty Provisions

Datamax makes no warranty as to the design, capability, capacity or suitability of any of its hardware, supplies, or software.

Software is licensed on an "as is" basis without warranty. Except and the extend expressly provided in this warranty and in lieu of all other warranties, there are no warranties, expressed or implied, including, but not limited to any warranties of merchantability or fitness for a particular purpose.

Purchaser shall be solely responsible for the selection, use, efficiency and suitability of Datamax's products.

Limitation of Liability

In no event shall Datamax be liable to the purchaser for any indirect, special or consequential damages or lost profits arising out of or relating to Datamax's products, or the performance or a breach thereof, even if Datamax has been advised of the possibility thereof. Datamax's liability, if any, to the purchaser or to the customer of the purchaser hereunder shall in no event exceed the total amounts paid to Datamax hereunder by the purchaser for a defective product.

In no event shall Datamax be liable to the purchaser for any damages resulting from or related to any failure or delay of Datamax in the delivery or installation of the computer hardware, supplies or software or in the performance of any services.

Some States do not permit the exclusion of incidental or consequential damages, and in those States the foregoing limitations may not apply. The warranties here give you specific legal rights, and you may have other legal rights which vary from State to State.

