

# CURTIS®

# MODEL 833

“FUEL” GAGE/HOUR METER  
W/“PUSH-



**Read Instructions Carefully !**



## Safety Instructions

This instrument was manufactured and tested according to the applicable technical standards. It complies with all the safety regulations as shipped from the factory.

Installation and startup must be performed by skilled personnel.

Failure to install and operate the unit in accordance with these instructions may result in damage or injury.

If safe operation of the instrument can no longer be ensured, stop and secure it against accidental operation.

If instrument failure or malfunction may cause personal injury or material damage, use additional safety measures such as limit switches, guards, etc.

Read the Operating Instructions carefully before startup.



Note the safety instructions marked with this warning symbol in this manual.

<b><u>TABLE OF CONTENTS</u></b>	<b><u>Page</u></b>
1. Model Encodement	2
2. Technical Specifications	
2.1 Electrical	4
2.2 Mechanical	5
2.3 Environmental	6
3. Installation	7
4. Operation	14
5. Troubleshooting	16
6. Maintenance	17



# 1. MODEL ENCODEMENT

833RB

vvvv

w

*Voltage*  
0024

*Reset level*  
B = 2.09 VPC

**x**

*Discharge profile*

C = Adjustable  
(See Table 3.)

**y**

*Output*

J = N.C. holding relay  
Contact rating =  
3 Amps  
when continuously  
closed, 1 Amp  
when opening

**zzzz**

3160

O = Curtis  
logo





## 2. TECHNICAL SPECIFICATIONS

### 2.1 Electrical Operating Range

± 25% of nominal voltage

#### Operating Current

Voltage (volts)	Nominal Current (mA)	Maximum Current (mA)
24	18	28

#### Relay Contact Ratings

Voltage: 200 VDC (max)

Current: 1 ADC (max)

(3 ADC max when continuously closed)

Power: 50 W (max)

## 2.2 Mechanical

### Display

Battery state-of-charge: 10-bar, tri-color LED

Hour Meter: 6-digit LCD, 5mm high



### Resolution

Hour Meter

99,999.9 Hours

### Hardware Kit

Mounting bracket, thumbnuts or M4 Hex nuts (2), lock washers (2), mating connector Molex No. 39-01-2085, w/pins No. 39-00-0039, no connectors in bulk shipments.

### Panel Cutout

52mm, 2 $\frac{1}{16}$ " diameter

## 2.3 Environmental



### Temperature

Operating:	-40°C to +65°C (Standard Mode)
	-10° C to +65° C (Push-to-read Mode)
Storage:	-50°C to +90°C

**Humidity** 95% RH (Non Condensing) at 38°C

**Shock & Vibration** 2.2 G, 20-200 Hz; 20 minute period;  
X,Y,Z, 13 cycles each

**Enclosure** IP65 (face)



### 3. INSTALLATION



The Model 833 Installation Kit includes a pre-assembled mating connector with 5" terminated wires.

Ask for Curtis Part Number 15369002.

The Model 833 fits into a dash-panel cutout measuring  $2\frac{1}{16}$ " (52 mm).

**Terminal Assignment** (see diagram on page 13)

**Pin 8 = Battery +**

Pin 8 to battery +

### **Pin 5 = Battery –**

Connect to battery ground as close to battery as possible.



### **Pin 2 = Keyswitch**

The keyswitch turns on and off the LED display of the battery discharge indicator. Monitoring of the battery continues when Pin 2 is turned off and the display is not lit.

The hour meter display is unaffected by Pin 2, although it cannot accumulate more time as long as the keyswitch pin is not energized. The control input HRM (+) is enabled by the keyswitch. Pin 2 is connected to the vehicle's keyswitch.

### **Pins 1, 2, 6 & 7 = Hour Meter Control (+)**

In normal operation, Pin 1, 6 or 7 are connected when using normal hour meter function. It is possible to OR the hour meter between the three inputs so that it accumulates the total time either system is on. Hour meter control logic is detailed in Table 2.

**Pin 3 = Relay (+)**

Pin 3 connects in series with the lift coil circuit (or the circuit to be switched at empty). For holding relay (J), Pin 3 must be electrically closer to battery + than Pin 4

**Pin 4 = Relay (-)**

Pin 4 also connects in series with the circuit to be switched at empty.

**Table 1. Hour Meter Control Lines & Impedance Specifications**

Model	Low Voltage	High Voltage	Min. Impedance	
	Maximum	Minimum	HRM+	HRM-
24 VDC	5.0 VDC	15.0 VDC	90 k $\Omega$	30 k $\Omega$

**Table 2. Hour Meter Control Logic**

Key switch	HRM (+)	HRM (+)	HRM (+)	Hour meter	Icon
Off	x	x	x	Display only	Steady
On	V <sub>H</sub>	x	x	On	Flashing
On	x	V <sub>H</sub>	x	On	Flashing
On	x	x	V <sub>H</sub>	On	Flashing
On	V <sub>L</sub> or open	V <sub>L</sub> or open	V <sub>L</sub> or open	Display only	Flashing



## NOTE: Fuses and Wires

Regulations may require that the Model 833 be fused. If installing a fuse, use a 10A fuse wired with 1.5mm or equivalent wire. The voltage drop across the fuse, its holder, and connectors must be less than 1% of the nominal system voltage.



## Discharge Adjustments

Table 3 lists the voltages per cell under load that correspond to an empty indication on the gauge (lockout point).

**Table 3. Discharge Adjustment Settings**

Setting	Volt/Cell at Empty
K	1.57
L	1.63
M	1.68
N	1.73 (factory setting)
O	1.78
P	1.82
Q	1.84
R	1.86
S	1.89
T	1.91
U	1.93

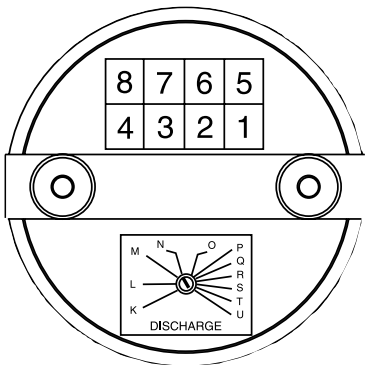

CURTIS Model 833 Rear View



## Connections for Typical Model 833 Application

Vehicle system voltage is the higher of the two operating voltages of a dual voltage unit. Hour meter measures "keyswitch on" time.

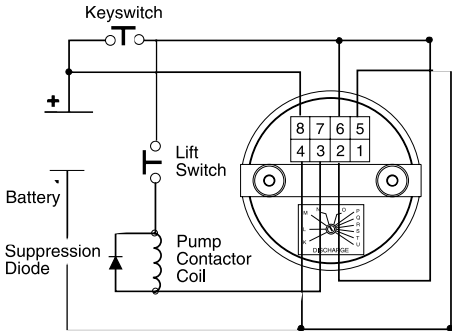

## 4. OPERATION

### Display

The Curtis Model 833 combines in one instrument a completely solid state LED battery state-of-charge indicator, an LCD hour meter, and lift lockout.

Only when battery is properly charged is right most LED (1) lit. As battery's state-of-charge decreases, successive LEDs light up, one at a time.

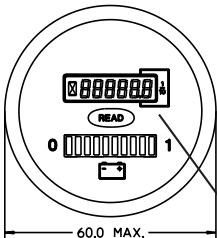

2nd from left LED flashes indicating "energy reserve" (70% discharged).

The left most 2 LEDs flash indicating "empty" (80% depth of discharge). At this point, lift lockout occurs.

**LCD Hour Meter**



## Push-to-read

When the front button is depressed, the LCD will display the hour meter reading for 6 seconds min. The hour meter will not accumulate time during this operation.

## Reset type/level (after or during recharge)

CTR = Charge Tracking Reset

If the gage is connected to the battery during recharge, the gage will track the battery charge level.

OCR = Open Circuit Reset

If the gage is disconnected from the battery during recharge, the gage will retain the last indication. It will advance to full when reconnected only if the battery voltage is above the OCR level. For standard ("B") reset, OCR = 2.09 VPC\*.

\*VPC = volts per cell.



## 5. Troubleshooting

The following checklist should help you to troubleshoot any problems with the instrument.

### **Problem**

No display

Stays at FULL

Will not reset

Resets w/o charging battery

EMPTY too soon

### **Possible Causes**

Terminals not connected or improper voltage

Instrument voltage does not match battery voltage, B+ connected to the wrong terminal

Instrument voltage does not match battery voltage, or battery not fully charged

Not connected directly to battery terminals

B+ connected to wrong terminal, or instrument voltage does not match battery voltage, or terminals not directly connected to battery

## **6. Maintenance**

Model 833 Series is not serviceable in the field. Units returned to the factory within the warranty period (see inside backcover) will be replaced without charge.

**Guarantee** - Curtis Instruments' products and/or components are guaranteed against defects in workmanship and material for a period of two years, or as defined in the individual product literature, from date of shipment from our factory, when applied in a proper application within specified ratings. This guarantee is limited to repair or replacement F.O.B. our factory. There is no further warranty or implied representation, guarantee, promise or agreement as to any Curtis Instruments product and/or component. Curtis Instruments, Inc., cannot assume responsibility or accept invoices for unauthorized repairs to its products and/or components, even though defective. In no case will Curtis Instruments' responsibility extend to products, components or equipment not of its manufacture. Under no circumstances shall Curtis Instruments, Inc., be liable for any special or consequential damages or loss of profits or other damages. Returned goods will not be accepted unless identified by a Curtis Return Material Authorization (RMA).

***All specifications are subject to change  
without notice.***

# **CURTIS®**

**CURTIS INSTRUMENTS, INC.**

**200 Kisco Avenue, Mt. Kisco, NY 10549**

**Tel. (914) 666-2971 • FAX (914) 666-2188**

53024 REV A 7/01