

INSTALLATION, OPERATION & MAINTENANCE MANUAL



**SINGLE PACKAGED ROOF TOP AIR CONDITIONERS
'PT' SERIES
MODELS: PT036 - PT360**

INDEX

Contents	Page
General	
Model decoding	2
General statement	3
Warranty	3
Safety issues	3
Inspection for damage	3
Installation instructions	
General	4
Location of unit	4
Service clearance	5
Rigging instructions	5
Condensate drain connection	6
Duct connection	6
Electric heater	6
Unit weight & weight distribution	6
Unit dimensions	7-11
Cable size	12
Operation instructions	
Start-up inspection & check list	12
Electrical data	13-14
Performex controller, operation & functions	15-16
Crankcase heater	16
Pump down control	16
Maintenance instructions	
Airflow adjustment	17
Crankcase heater	17
Cleaning of coils & filters	17
Belt tension testing procedure	17-18
Field wiring connections	18
Preventive maintenance schedule	19
Trouble shooting chart	20-21
Typical schematic wiring diagram	22-29
Parts list	30

*CONTINUING RESEARCH RESULTS IN STEADY IMPROVEMENTS.
THEREFORE, THESE SPECIFICATIONS ARE SUBJECT TO CHANGE WITHOUT NOTICE.*

MODEL DECODING

MODELS: PT036 - PT060 (DIRECT DRIVE MOTOR)

1&2 BASIC	3, 4 & 5 NOMINAL COOLING CAPACITY (MBH)	6 ELECTRICAL SUPPLY (V-Ph-Hz)	7 REFRIGERATION CIRCUIT	8 BLOWER MOTOR	9 DRIVE OPTIONS	10 HEATER OPTIONS (KW/STAGE)	11 EVAPORATOR COIL	12 CONDENSER COIL	13 PDS OPTION	14 OTHER OPTIONS	15 UNIT ACCESSORIES
PT COOLINE PACKAGED UNIT	036	L : 380/415-3-50 (4 WIRE)	S : SINGLE	W : 0.75 HP ODP	N : DIRECT DRIVE	N : NO HEATER A : 5/1 B : 6/1 C : 7.5/1 D : 10 /2 E : 12/2	J : IGT + ENHANCED AL. FINS K : IGT + ENHANCED MHG. FINS L : IGT + CORRU-GATED CU. FINS	J : IGT + ENHANCED AL. FINS K : IGT + ENHANCED MHG. FINS L : IGT + CORRU-GATED CU. FINS	N : NO PDS OPTION P : PDS OPTION	N : STANDARD UNIT I : ANTI-ICE U : UVM V : VOLT FREE CONTACT	N : STANDARD UNIT C : FRESH AIR MANUAL DAMPER
	048			W : 0.75 HP ODP							
	060			Y : 1 HP ODP							

MODELS: PT075 - PT360 (BELT DRIVEN MOTOR)

1&2 BASIC	3, 4 & 5 NOMINAL COOLING CAPACITY (MBH)	6 ELECTRICAL SUPPLY (V-Ph-Hz)	7 REFRIGERATION CIRCUIT	8 BLOWER MOTOR	9 DRIVE OPTIONS	10 HEATER OPTIONS (KW/STAGE)	11 EVAPORATOR COIL	12 CONDENSER COIL	13 PDS OPTION	14 OTHER OPTIONS	15 UNIT ACCESSORIES
PT COOLINE PACKAGED UNIT	075	L : 380/415-3-50 (4 WIRE)	S : SINGLE	C : 1.5 HP ODP	J : ALT. I K : ALT. II	N : NO HEATER A : 5/1* B : 6/1* C : 7.5/1 D : 10 /2 E : 12/2 F : 15 /2 G : 20 /2 C : 7.5/1 D : 10 /2 E : 12/2 F : 15 /2 G : 20 /2 H : 25/2 J : 30/2**	J : IGT + ENHANCED AL. FINS K : IGT + ENHANCED MHG. FINS L : IGT + CORRU-GATED CU. FINS	J : IGT + ENHANCED AL. FINS K : IGT + ENHANCED MHG. FINS L : IGT + CORRU-GATED CU. FINS	N : NO PDS OPTION P : PDS OPTION	N : STANDARD UNIT I : ANTI-ICE U : UVM V : VOLT FREE CONTACT	N : STANDARD UNIT C : FRESH AIR MANUAL DAMPER
				D : 2 HP ODP							
				D : DUAL							
	090		D : 2 HP ODP	J : 7.5 HP ODP K : 7.5 HP TEFC L : 10 HP ODP M : 10 HP TEFC							
	100		E : 3 HP ODP								
	120***		F : 3 HP TEFC								
	180		G : 5 HP ODP	J : 7.5 HP ODP K : 7.5 HP TEFC L : 10 HP ODP M : 10 HP TEFC							
215	H : 5 HP TEFC										
240	J : 7.5 HP ODP	J : 7.5 HP ODP K : 7.5 HP TEFC L : 10 HP ODP M : 10 HP TEFC									
300	K : 7.5 HP TEFC										
360	L : 10 HP ODP	J : 7.5 HP ODP K : 7.5 HP TEFC L : 10 HP ODP M : 10 HP TEFC									
	M : 10 HP TEFC										
	N : 15 HP ODP	J : 7.5 HP ODP K : 7.5 HP TEFC L : 10 HP ODP M : 10 HP TEFC									
	P : 15 HP TEFC										

NOTE: * - Applicable for PT075 models only.

** - Applicable for models PT180 & above only.

*** - 3 HP motor only available for PT120.

GENERAL

GENERAL STATEMENT

This unit is from the PT series that was designed & built for the optimum performance. However, it is required that you become well acquainted with good practices for the proper installation/operation/and maintenance procedures in order to ensure a safe trouble free operation, year after year.

Please read through the whole manual contents before you attempt to install/operate/ and maintain the unit.

Most of the procedures described in this manual require certain skills and experience. The installation and other maintenance procedures should be performed only by highly skilled and experienced technicians. The end user's role should be limited to the cleaning of the filter.

Please consult your nearest "COOLINE" representative for further information.

The PT units can be supplied, depending on the End User requirement, as the basic "Cool Only" version, or the "Heat & Cool" version (with electric heater module).

WARRANTY

All of the PT series of Packaged Roof Top Units are covered by the standard warranty terms against any manufacturer defect. Should you encounter any problem that falls under the warranty terms please contact your nearest "COOLINE" representative.

SAFETY ISSUES

There are three degrees of safety hazards that are identified throughout this manual as **WARNING** (where the situation will result in personal injury), **CAUTION** (where personal injury might occur), and **ATTENTION** (where minor personal injury and/or property damage could happen). Please understand and respect those identifications.



WARNING: The PT units operate on a high voltage with moving parts (at high speed) which can lead to serious injuries and/or damage to the unit. Never attempt to service the unit unless the main electrical power supply has been disconnected.



CAUTION: Extra care should be observed when installing, test running, adjusting, servicing, or maintaining the unit as the hazard of explosion, fire, electrical shock, and potential personal injury and property damage are present.

When performing any task pertaining to the installation and maintenance of the unit, the skilled technician should observe all the applicable safety measures (wear of safety helmet, boots, gloves, and goggles. Use of proper handling materials for brazing and use of wet cloth for quenching. A fire extinguisher should be easily accessible etc.). He should also read all the instructions and information in this Manual prior to attempting to perform any installation or servicing of the unit.

All applicable local codes should also be observed.

INSPECTION FOR DAMAGE

The unit should be carefully inspected visually for any sign of physical damage due to mishandling. Whenever a damage is detected, please indicate it on the corresponding delivery note before you sign it and inform your nearest "COOLINE" office.

INSTALLATION INSTRUCTIONS

GENERAL

These units are shipped completely assembled, charged, and wired. They do not require any field installation of refrigerant tubing. Units require external power, thermostat wiring, condensate drain piping and ducting as applicable.

Size of unit for an installation should be based on a heat gain calculation made according to applicable standards. Units must also be installed in accordance with regulations of the "National Fire Protection Association" and local electrical codes. Where local regulations conflicts with the instructions in this manual, installer should adhere to local standards.

Prepare your concrete pad or steel stand based on the corresponding dimensions. Remove shipping protective covers and wooden crating and lift unit from base and place in position with suitable rubber vibration isolators.

All field installed accessories are to be installed by the customer with necessary reinforcements as required.

LOCATION OF UNIT

When selecting the location for the unit, the following points should be kept in mind:

1. Provisions for a concrete pad or steel stand base.
2. That the terrain allows for drainage away from the unit.
3. If the unit is to be roof mounted, inspect the roof for load bearing capacity. The roof should have sufficient structural strength to carry the weight of the unit.
4. Install unit on vibration isolation pads, i.e. on rubber mounting pads.
5. Availability of electric power.
6. To position the unit for unrestricted air circulation of the condenser air inlet and to prevent any possibility of air recirculation from the condenser fan discharge air (see figure on next page).
7. Check minimum clearances required for your unit, with regard to walls, or other obstructions (see figure on next page).
8. Air cooled equipment should not be installed under low structural overhangs which can cause condenser air recirculation or restriction. Observe minimum of clearance (see figure on next page).
9. Care should be taken to prevent air from other sources from entering condenser, if this air is at a high temperature.
10. Level the unit on its final location and be sure that the levelling tolerance is ± 5 mm per linear meter in any direction.



CAUTION: Do not install the unit as indoor unit, install it in an open area, and unit air inlets must not be located near exhaust vents or other source of contaminated air.

SERVICE CLEARANCE

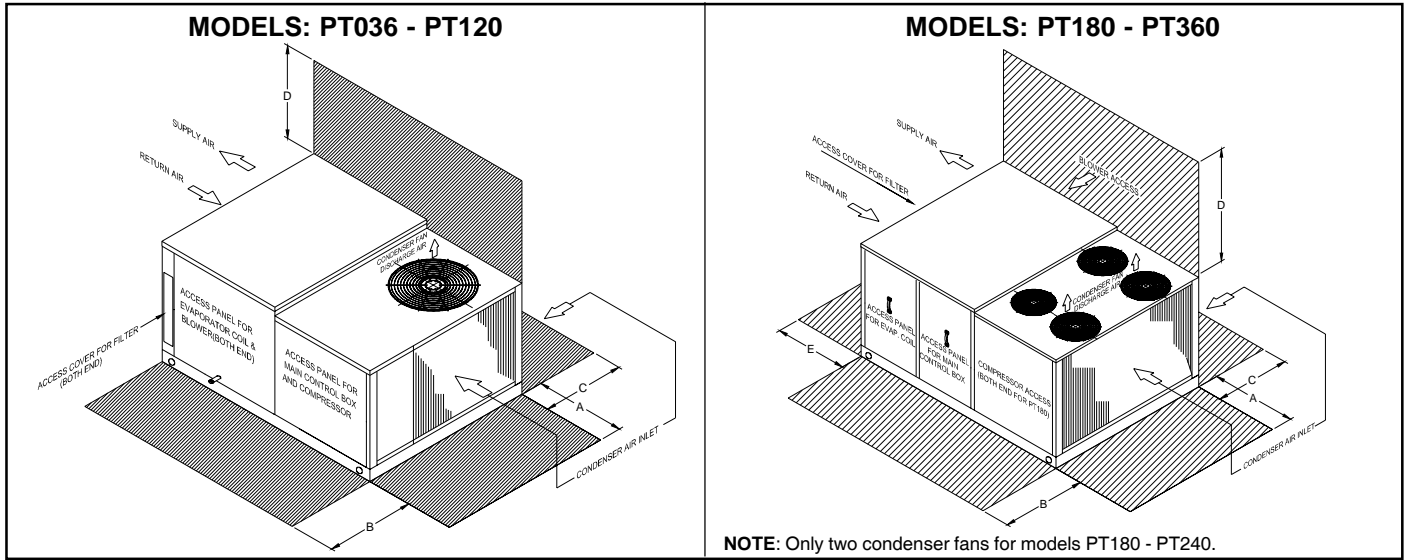

NOTE: Only two condenser fans for models PT180 - PT240.

NOTE: All dimensions are in cm.

MODEL NUMBER	DIMENSIONS			
	A	B	C	D
PT036	85	105	85	150
PT048	85	105	85	150
PT060	85	105	85	150
PT075	90	105	90	200
PT090	90	105	90	200
PT100	90	105	90	200
PT120	90	105	90	200

MODEL NUMBER	DIMENSIONS				
	A	B	C	D	E
PT180	120	120	115	250	90
PT215	120	120	115	250	90
PT240	120	120	115	250	90
PT300	120	120	115	250	90
PT360	120	120	115	250	90

- A : Clearance dimension from condenser coil
- B : Clearance dimension from compressor, control box, blower, evaporator coil & filter
- C : Clearance dimension from condenser coil & filter
- D : Clearance dimension over the condenser fan

- A : Clearance dimension from condenser coil
- B : Clearance dimension from compressor box & evaporator coil
- C : Clearance dimension from condenser coil & blower
- D : Clearance dimension over the condenser fan
- E : Clearance dimension from filter access panel

RIGGING INSTRUCTIONS

ATTENTION TO RIGGERS

- Insert 2" nominal pipe through holes in the base rail as shown in the figure below for slings.
- Holes in base rail are centered around the unit center of gravity.
- Use wooden pallet or spreader bar when rigging, to prevent the slings from damaging the unit.
- Rollers may be used to move the unit on the roof or ground.



CAUTION: All panels should be in place when rigging.

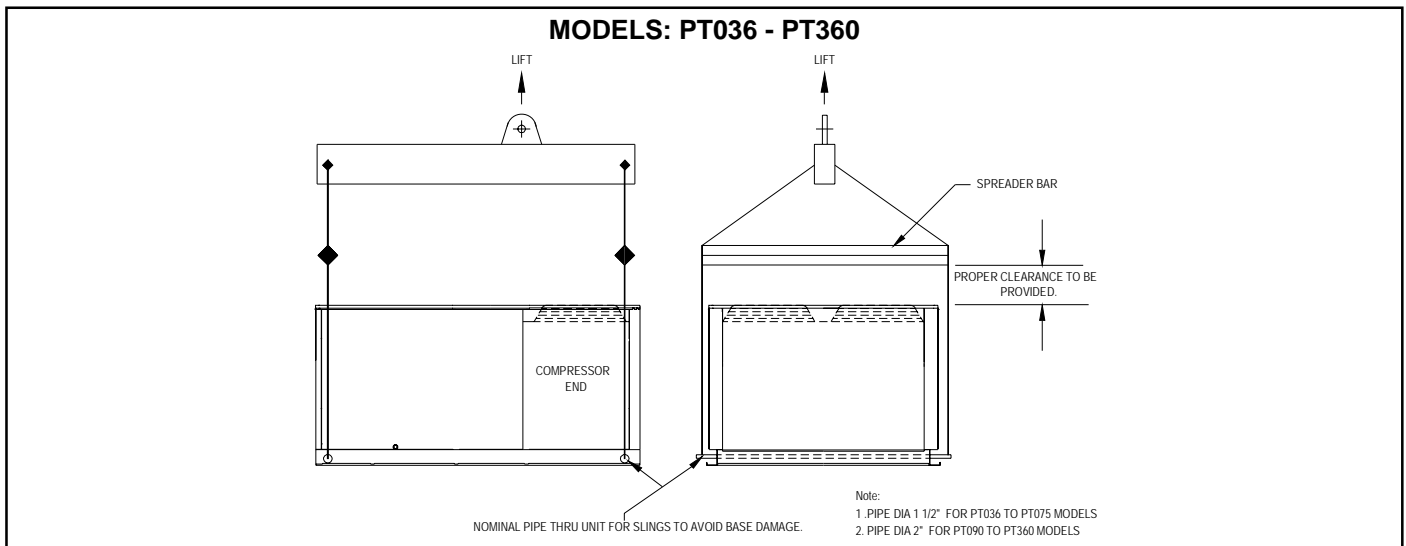

CONDENSATE DRAIN CONNECTION

- Use standard PVC pipe with NPT connection for the condensate drain. Provide a 'P' trap immediately at the condensate drain connection.
- Piping has to be sloped away from the unit.
- Remember to remove the drain hole plug before operating the unit. Avoid bends & elbows.

DUCT CONNECTION

The units can be connected to the ducting in horizontal configuration. Connect ducting using flexible duct connection. The duct should be properly designed and the drive package should match the required CFM & corresponding external static pressure.



ATTENTION: Avoid abrupt changes in size and/or direction of duct to ensure proper unit performance.

ELECTRIC HEATERS

Electric heater kit is installed in the unit at the supply air opening space.

UNIT WEIGHT & WEIGHT DISTRIBUTION

MODEL NUMBER	WEIGHTS (Kg.)					
	J	K	M	L	P	Q
PT036	67	36	51	34	-	-
PT048	72	41	57	39	-	-
PT060	76	45	62	42	-	-
PT075	86	52	70	45	-	-
PT090	116	92	95	73	-	-
PT100	134	91	98	73	-	-
PT120	135	91	98	73	-	-
PT180	155	99	152	85	108	105
PT215	182	89	94	101	177	103
PT240	186	94	98	105	181	107
PT300	226	130	202	148	221	158
PT360	256	145	216	151	249	175

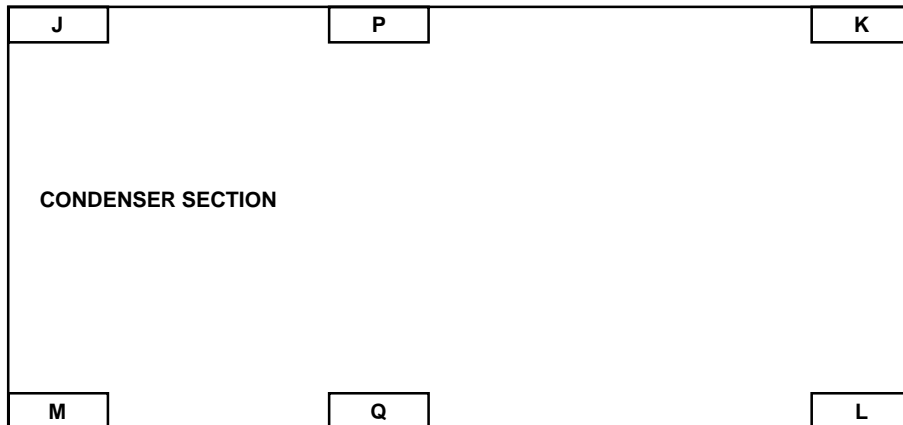

↓ ↑
SUPPLY AIR/
RETURN AIR

UNIT DIMENSIONS

PT036 - PT075

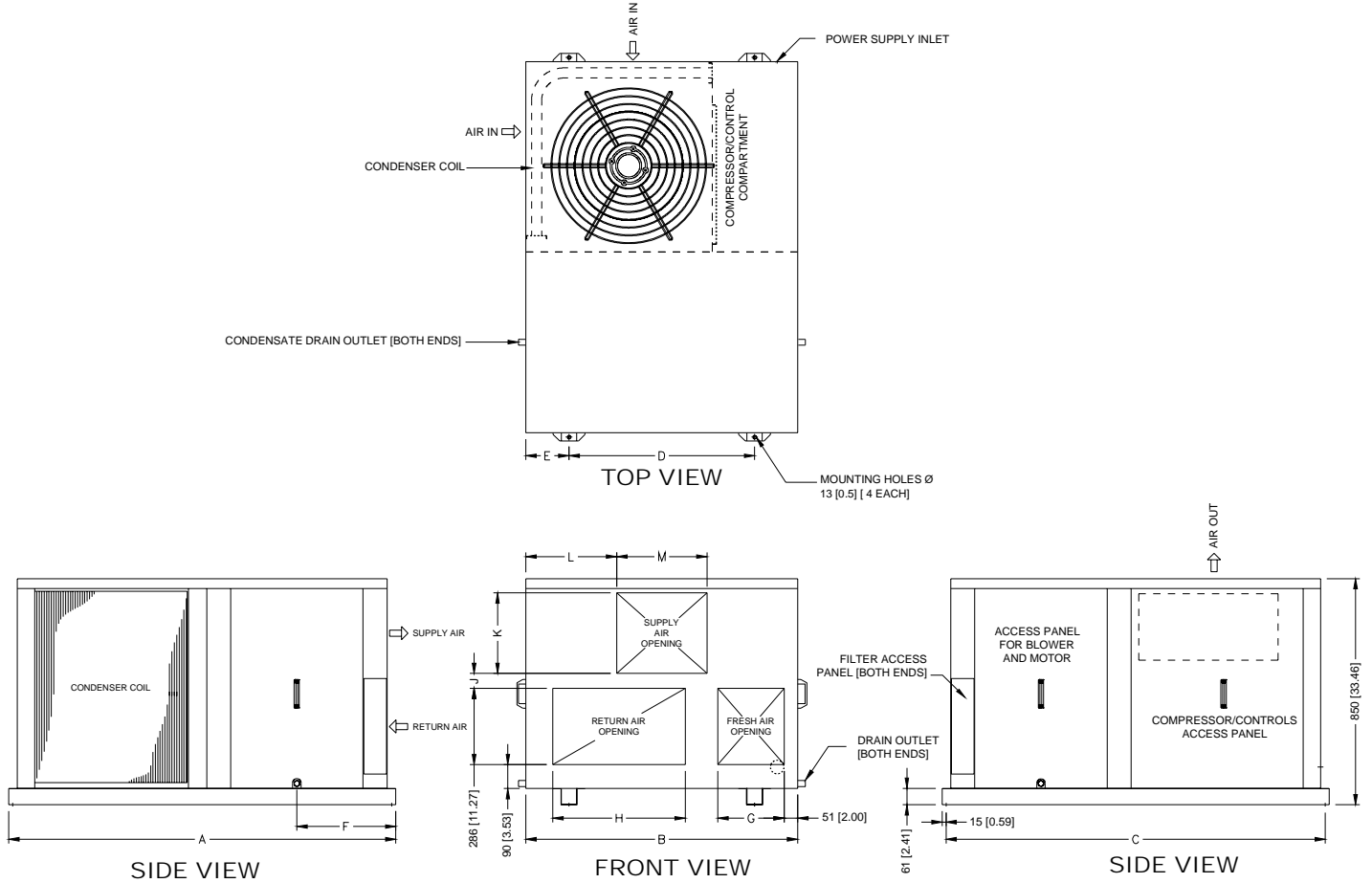

MODEL	DIMENSIONS											
	A	B	C	D	E	F	G	H	J	K	L	M
PT036 - PT060	1460(57.48)	1025(40.35)	1430(56.3)	700(27.56)	163(6.42)	373(14.68)	250(9.84)	500(19.69)	57(2.24)	304(11.96)	343(13.49)	340(13.39)
PT075	1775(69.88)	1150(45.28)	1745(68.7)	800(31.5)	175(6.89)	480(18.9)	325(12.8)	672(26.46)	80(3.15)	280(11.02)	275(10.83)	600(23.62)

NOTE:

1. All dimensions are in mm (dimensions in brackets are in inches).
2. Service clearance should be 1200mm (4 feet) on all sides.

UNIT DIMENSIONS

PT090 - PT120

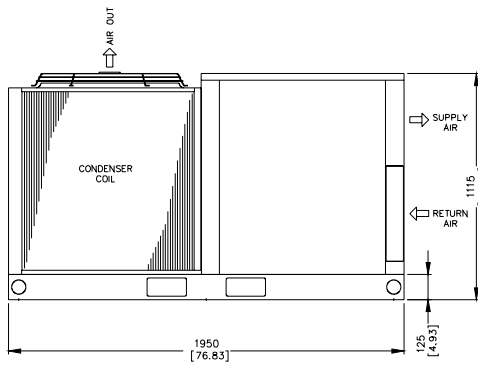
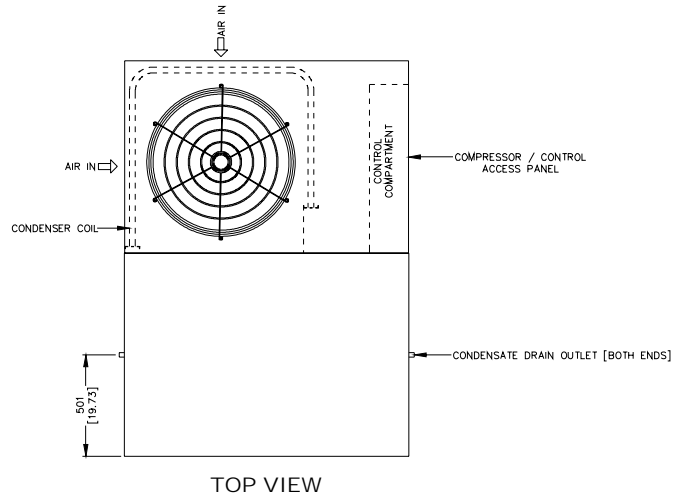

SIDE VIEW

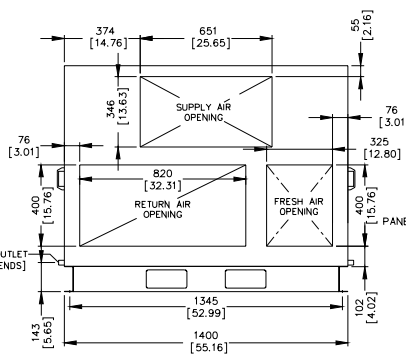

FRONT VIEW

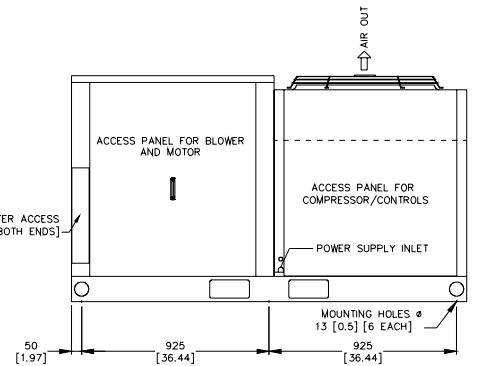

SIDE VIEW

NOTE:

1. All dimensions are in mm (dimensions in brackets are in inches).
2. Service clearance should be 1200mm (4 feet) on all sides.

UNIT DIMENSIONS

PT180

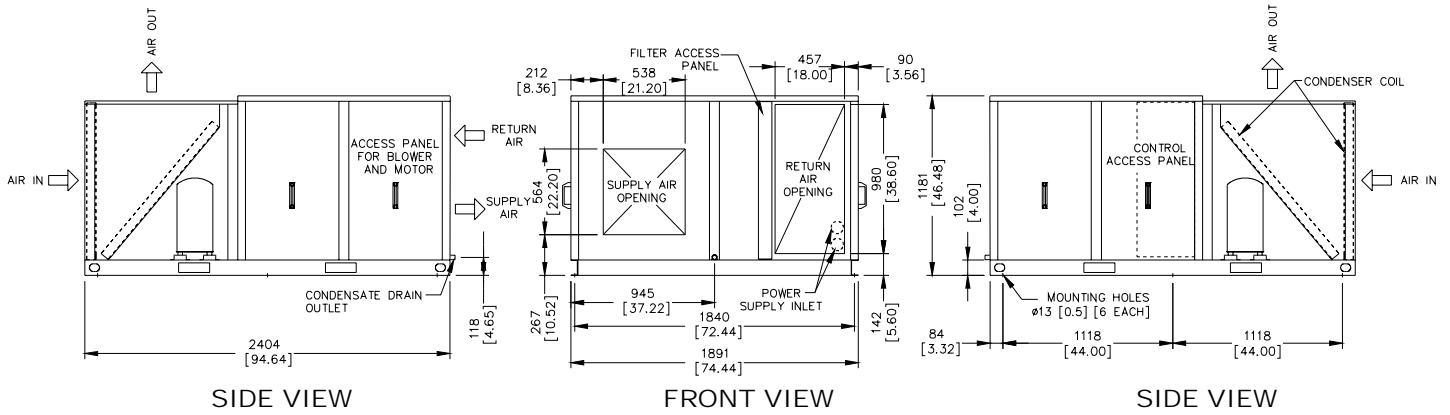
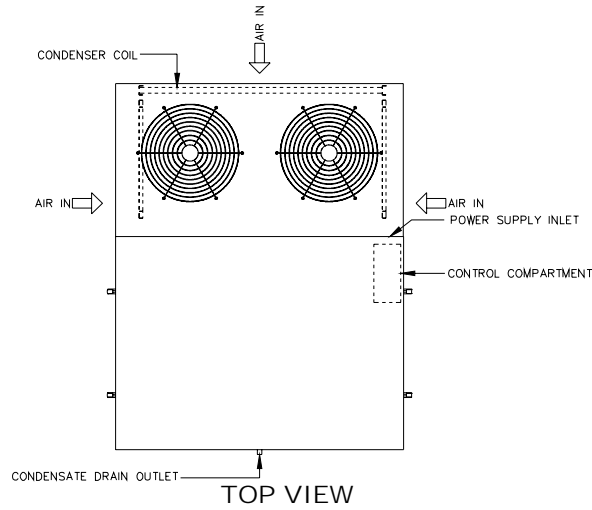

NOTE:

1. All dimensions are in mm (dimensions in brackets are in inches).
2. Service clearance should be 1200mm (4 feet) on all sides.

UNIT DIMENSIONS

PT215 - PT240

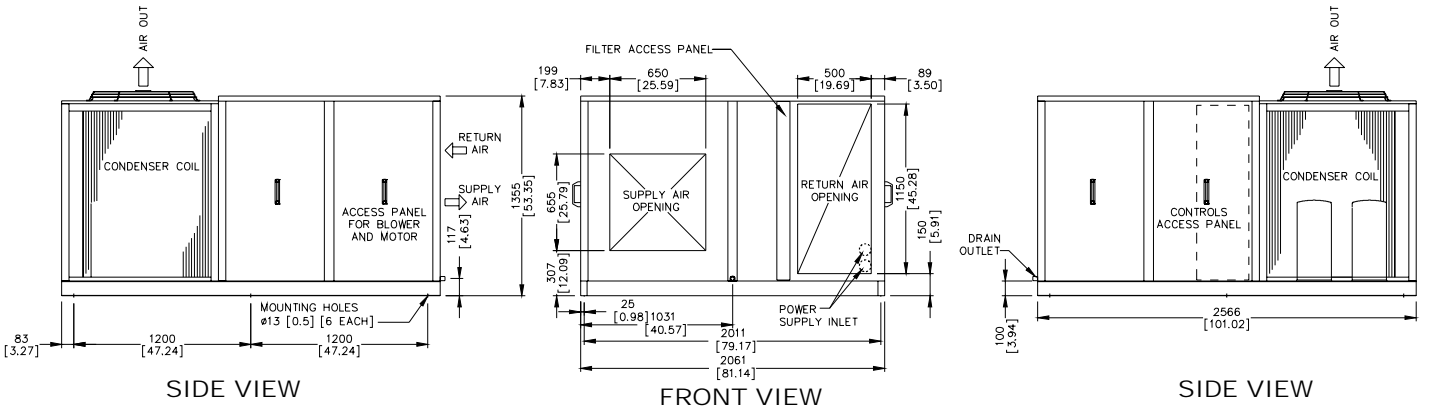
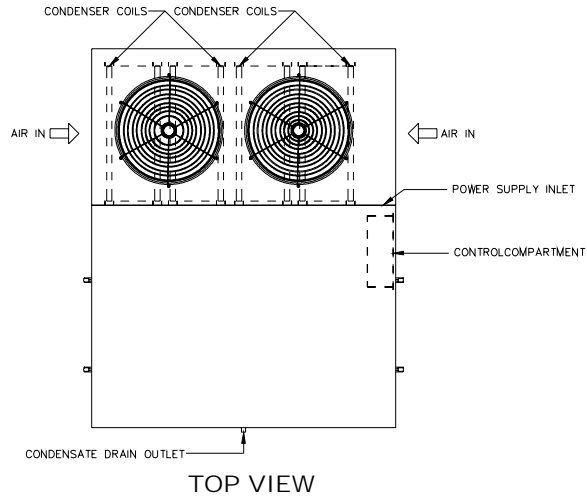

NOTE:

1. All dimensions are in mm (dimensions in brackets are in inches).
2. Service clearance should be 1200mm (4 feet) on all sides.

UNIT DIMENSIONS

PT300 - PT360

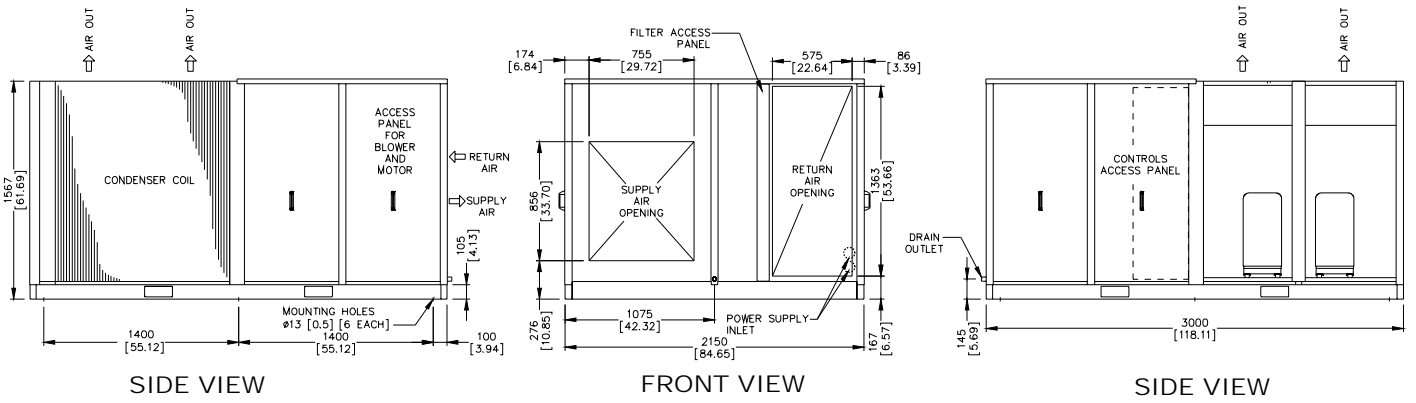
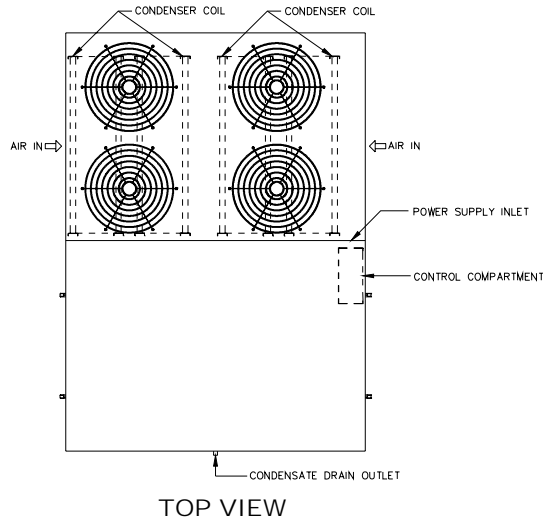

NOTE:

1. All dimensions are in mm (dimensions in brackets are in inches).
2. Service clearance should be 1200mm (4 feet) on all sides.

CABLE SIZE

- All wiring should be in accordance with local standards.
- Before making any connection, check the electric power supply, it must have the same characteristics as what is displayed in the nameplate.
- For selecting cable size, refer to wire ampacity table at different MCA (Minimum Circuit Amps) provided in unit electrical data, which is listed as a guideline (see table below).
- Wiring connection to the unit must have suitable insulation of a minimum temperature of 60°C.

POWER SUPPLY	MODEL No.	MCA	CONDUCTOR SIZE	
			AWG	METRIC MM ²
380/415-3-50 (4 wire)	PT036	15.2	14	2.5
	PT048	20.8	12	4
	PT060	22.1	12	4
	PT075	20.9	12	4
	PT090	25.1	10	6
	PT100	30	10	6
	PT120	33.6	8	10
	PT180	54.8	6	16
	PT215	60	6	16
	PT240	65	4	25
	PT300	80.3	3	26.6
PT360	92.8	2	33.6	

LEGEND: MCA - Minimum Circuit Amps

- Notes:**
1. Customer is to select cable size also with cross reference as per cable manufacturer data for voltage reduction per unit length. The above cable ampacity table is for guidance only.
 2. The selected cables for specified units is as per following characteristics:
 - a. Unit without electric heaters.
 - b. Any extra electrical accessories shall add to MCA rate, for more information, refer to unit electrical tables in the catalog.

OPERATION INSTRUCTIONS

START-UP INSPECTION & CHECK LIST

After the installation is completed in all respect, the following points should be covered before the system is switched on for operation.

1. Check unit location as per installation instructions.
2. Make sure all electrical fasteners/connections are tight and clean.
3. All controls are set according to manufacturer's instructions (low & high pressure switch, pump down solenoid, etc...)
4. Make sure all valves are open (compressor suction & discharge service valves, liquid line, etc.).
5. Follow all the instructions from the warning tags and stickers.
6. Check if condenser & blower fan are free to turn without wobbling.
7. Remove straps & wooden pieces that holds the compressor in place during transportation.
8. Compressor crankcase heater should be energized for 24 hours (special attention should be taken to disable compressor contactor before energizing the unit).
9. Expansion valve bulb is strapped properly at correct location (applicable for PT075 - PT360 only).
10. Circuit breaker/fused disconnect switch.
11. Blower fan belt is properly tightened and pulleys are properly aligned (applicable for PT075 - PT360 only).
12. All refrigerant service valve caps are installed.
13. All piping, piping insulation and piping supports are properly installed.
14. Thermostat is the right one and installed properly.
15. Connect the manifold gauge to suction & discharge line service valves. Prepare recommended instruments for checking Voltage, Amps, RPM, CFM, static pressure, etc.
16. Start the blower fan and condenser fan. Check the amperage against the nameplate ampere.
17. Start the compressor & observe the compressor discharge and suction pressures. If not within system design limits, determine why & take corrective action.

ELECTRICAL DATA

MODELS: PT036 - PT060

MODEL NUMBER	POWER SUPPLY (V-Ph-Hz)	VOLTAGE RANGE		FM	COMPRESSOR			BLOWER MOTOR		ELECTRIC HEATER		MCA	MOCP
		MIN.	MAX.		FLA	RLA	LRA	HP	FLA	kW	FLA		
PT036	380/415-3-50 (4 WIRE)	342	457	2.3	5.9	42	0.75	5.5	-	-	15.2	20	
									5/6	7.6/9.1	16.4/18.3	20/20	
									7.5/10*	11.4/15.2	21.1/25.9	25/30	
PT048	380/415-3-50 (4 WIRE)	342	457	2.3	10.4	55	0.75	5.5	-	-	20.8	30	
									5/6	7.6/9.1	20.8/20.8	30/30	
									7.5/10*	11.4/15.2	21.1/25.9	35/30	
PT060	380/415-3-50 (4 WIRE)	342	457	2.3	9.6	65	1	7.8	-	-	22.1	30	
									5/6	7.6/9.1	22.1/22.1	30/30	
									7.5/10*	11.4/15.2	24/28.8	30/30	
									12*	18.2	32.5	35	

LEGEND:

- FLA - Full Load Amps
- HP - Horse Power
- BM - Blower Motor
- LRA - Locked Rotor Amps
- RLA - Rated Load Amps
- MCA - Minimum Circuit Amps
- MOCP - Maximum Over Current Protection
- FM - Fan Motor (Condenser)
- *Combination of heater modules

MODELS: PT075 & PT090

DESCRIPTION				MODEL NUMBER															
				PT075								PT090							
POWER SUPPLY (V-Ph-Hz)	VOLTAGE RANGE		FM (each)	COMPRESSOR (each)		BM		ELECTRIC HEATER		MCA	MOCP	COMPRESSOR (each)		BM		ELECTRIC HEATER		MCA	MOCP
	Min.	Max.	FLA	RLA	LRA	HP	FLA	Nom. kW	FLA			RLA	LRA	HP	FLA	Nom. kW	FLA		
380/415-3-50 (4 WIRE)	342	457	2.3 (1.9 FOR PT090)	12	101	1.5	3.4	-	-	20.7	30	2	3.6	-	-	24	30	8.2	50
								5/6	7.6/9.1	20.7/20.7	30/30			5/6	7.6/9.1	24/24	30/30		
								7.5/10*	11.4/15.2	20.7/23.3	30/30			7.5/10*	11.4/15.2	24/24	30/30		
								12*/15*	18.2/22.8	27/32.8	30/35			12*/15*	18.2/22.8	27.3/33	30/35		
								12*/15*	18.2/22.8	27/32.8	30/35			20*	30.4	42.5	45		
								20*	30.4	42.5	45			20*	30.4	42.5	45		
	342	457	2.3 (1.9 FOR PT090)	12	101	2	3.6	-	-	20.9	30	3	4.7	-	-	25.1	30	10	74
								5/6	7.6/9.1	20.9/20.9	30/30			5/6	7.6/9.1	25.1/25.1	30/30		
								7.5/10*	11.4/15.2	20.9/23.5	30/30			7.5/10*	11.4/15.2	25.1/25.1	30/30		
								12*/15*	18.2/22.8	27.3/33	30/35			12*/15*	18.2/22.8	28.6/34.4	30/35		
								12*/15*	18.2/22.8	27.3/33	30/35			20*	30.4	43.9	45		
								20*	30.4	43.9	45			20*	30.4	43.9	45		

MODELS: PT100 & PT120

DESCRIPTION				MODEL NUMBER															
				PT100								PT120							
POWER SUPPLY (V-Ph-Hz)	VOLTAGE RANGE		FM (each)	COMPRESSOR (each)		BM		ELECTRIC HEATER		MCA	MOCP	COMPRESSOR (each)		BM		ELECTRIC HEATER		MCA	MOCP
	Min.	Max.	FLA	RLA	LRA	HP	FLA	Nom. kW	FLA			RLA	LRA	HP	FLA	Nom. kW	FLA		
380/415-3-50 (4 WIRE)	342	457	1.9	10.4	55	2	3.6	-	-	28.9	35	10	74	-	-	29.1	35	3	4.7
								7.5/10	11.4/15.2	28.9/28.9	35/35			7.5/10	11.4/15.2	29.1/29.1	35/35		
								10*/12*	15.2/18.2	28.9/28.9	35/35			10*/12*	15.2/18.2	29.1/29.1	35/35		
								15*/20*	22.8/30.4	33/42.5	35/45			15*/20*	22.8/30.4	34.4/43.9	35/45		
								15*/20*	22.8/30.4	33/42.5	35/45			25*	38	53.4	60		
								25*	38	53.4	60			25*	38	53.4	60		
	342	457	1.9	10.4	55	3	4.7	-	-	30	40	5	9.2	-	-	33.6	40	10	74
								7.5/10	11.4/15.2	30/30	40/40			7.5/10	11.4/15.2	33.6/33.6	40/40		
								10*/12*	15.2/18.2	30/30	40/40			10*/12*	15.2/18.2	33.6/34.3	40/40		
								10*/12*	15.2/18.2	30/30	40/40			15*/20*	22.8/30.4	40/49.5	40/50		
								15*/20*	22.8/30.4	34.4/43.9	40/45			15*/20*	22.8/30.4	40/49.5	40/50		
								15*/20*	22.8/30.4	34.4/43.9	40/45			25*	38	59	60		

ELECTRICAL DATA

MODELS: PT180 & PT215

DESCRIPTION				MODEL NUMBER															
				PT180								PT215							
POWER SUPPLY (V-Ph-Hz)	VOLTAGE RANGE		FM (each)	COMPR-ESSOR (each)		BM		ELECTRIC HEATER		MCA	MOCP	COMPR-ESSOR (each)		BM		ELECTRIC HEATER		MCA	MOCP
	Min.	Max.	FLA	RLA	LRA	HP	FLA	Nom. kW	FLA			RLA	LRA	HP	FLA	Nom. kW	FLA		
380/415-3-50 (4 WIRE)	342	457	1.9	17.3 & 16.4	111 & 95	5	9.2	-	-	51	60	19.2	125	5	9.2	-	-	56.2	70
								7.5/10	11.4/15.2	51/51	60/60					7.5/10	11.4/15.2	56.2/56.2	70/70
								10*/12*	15.2/18.2	51/51	60/60					10*/12*	15.2/18.2	56.2/56.2	70/70
								15*/20*	22.8/30.4	51/51	60/60					15*/20*	22.8/30.4	56.2/56.2	70/70
								25*/30*	38/45.6	59/68.5	60/70					25*/30*	38/45.6	59/68.5	70/70
				7.5/10	11.4/15.2	54.8	70	-	-	60	70								
				10*/12*	15.2/18.2	54.8/54.8	70/70	7.5/10	11.4/15.2	60/60	70/70								
				15*/20*	22.8/30.4	54.8/54.8	70/70	10*/12*	15.2/18.2	60/60	70/70								
				25*/30*	38/45.6	63.8/73.3	70/80	15*/20*	22.8/30.4	60/60	70/70								
				35*/40*	53.2/60.8	63.8/73.3	70/80	25*/30*	38/45.6	63.8/73.3	70/80								

MODELS: PT240 & PT300

DESCRIPTION				MODEL NUMBER															
				PT240								PT300							
POWER SUPPLY (V-Ph-Hz)	VOLTAGE RANGE		FM (each)	COMPR-ESSOR (each)		BM		ELECTRIC HEATER		MCA	MOCP	COMPR-ESSOR (each)		BM		ELECTRIC HEATER		MCA	MOCP
	Min.	Max.	FLA	RLA	LRA	HP	FLA	Nom. kW	FLA			RLA	LRA	HP	FLA	Nom. kW	FLA		
380/415-3-50 (4 WIRE)	342	457	1.9	19.6	118	7.5	13	-	-	60.9	80	25.6	167	7.5	13	-	-	78.2	100
								7.5/10	11.4/15.2	60.9/60.9	80/80					10*/12*	15.2/18.2	78.2/78.2	100/100
								10*/12*	15.2/18.2	60.9/60.9	80/80					15*/20*	22.8/30.4	78.2/78.2	100/100
								15*/20*	22.8/30.4	60.9/60.9	80/80					25*/30*	38/45.6	78.2/78.2	100/100
								25*/30*	38/45.6	63.8/73.3	80/80					35*/40*	53.2/60.8	82.8/92.3	100/100
				7.5/10	11.4/15.2	63	80	-	-	80.3	100								
				10*/12*	15.2/18.2	63/63	80/80	10*/12*	15.2/18.2	80.3/80.3	100/100								
				15*/20*	22.8/30.4	63/63	80/80	15*/20*	22.8/30.4	80.3/80.3	100/100								
				25*/30*	38/45.6	66.4/75.9	80/80	25*/30*	38/45.6	80.3/80.3	100/100								
				35*/40*	53.2/60.8	66.4/75.9	80/80	35*/40*	53.2/60.8	85.4/94.9	100/100								

MODEL: PT360

DESCRIPTION				MODEL NUMBER													
				PT360													
POWER SUPPLY (V-Ph-Hz)	VOLTAGE RANGE		FM (each)	COMPR-ESSOR (each)		BM		ELECTRIC HEATER		MCA	MOCP						
	Min.	Max.	FLA	RLA	LRA	HP	FLA	Nom. kW	FLA								
380/415-3-50 (4 WIRE)	342	457	1.9	27.8	198	10	15.1	-	-	85.3	110						
								10*/12*	15.2/18.2	85.3/85.3	110/110						
								15*/20*	22.8/30.4	85.3/85.3	110/110						
								25*/30*	38/45.6	85.3/85.3	110/110						
								35*/40*	53.2/60.8	85.4/94.9	110/110						
								-	-	92.8	110						
10*/12*	15.2/18.2	92.8/92.8	110/110														
15*/20*	22.8/30.4	92.8/92.8	110/110														
25*/30*	38/45.6	92.8/92.8	110/110														
35*/40*	53.2/60.8	94.8/104.3	110/110														

LEGEND:

- FLA - Full Load Amps
- HP - Horse Power
- BM - Blower Motor
- LRA - Locked Rotor Amps
- RLA - Rated Load Amps
- MCA - Minimum Circuit Amps
- MOCP - Maximum Over Current Protection
- FM - Fan Motor (Condenser)
- *Combination of heater modules

Performex-1™ CONTROLLER : OPERATION & FUNCTIONS

The COOLINE Packaged units are provided with technologically advanced new **Performex™ Controller** Microprocessor Based Electronic Control Board, incorporating the following benefits and features:

- **COMPLETE UNIT CONTROL:** Provides complete unit control for heating and cooling application whether single stage or two stage utilizing the input from sensor that measure temperatures during unit operation.
- **COMPRESSOR LOCKOUT:** If any of the unit's safety controls trip due to abnormal conditions the Electronic Control locks out the compressor, preventing restart, unless attended by qualified service technicians. The unit can be re-started only by reset the thermostat after ensuring safe system conditions.
- **LEAD LAG OPERATION:** The unit electronic controls automatically alternate lead and lag the compressors for even operation. Compressor #1 can be set always lead as an option.
- **ANTI-RECYCLE TIMER:** For compressor safety in case of accidental manual reset or immediate recycling of thermostat due to load demand. This considerably improves compressor life.
- **PUMP DOWN OPTION:** In units equipped with pump down system the time delay creates the required time gap between the solenoid opening and compressor start to equalize the pressure in the system prior to compressor start up.
- **AUTO/MANUAL RESET OF THE ALARM SIGNALS.**
- **FULL CONTROL OF THE INDOOR FAN:** Fan operation can be selected either to run continuously or stage with the compressor/heaters.

- **PROTECTION: The Performex™ Controller will provide the following protection:**
 1. Compressor high pressure protection (option)
 2. Compressor low pressure protection

ELECTRONIC THERMOSTAT

LCD display: a) Room temperature display

b) Mode of operation (Cool/Heat/Auto/Fan system control)

c) Set temperature

d) Compressor Status - ON/OFF/FAULT

e) Error Codes

1. **ON/OFF:** Press the ON/OFF button & the unit shall be switched ON. A status Led adjacent to this button shall light up indicating the unit is switched ON. To shut off the unit, press this button again.
2. **MODE:** Press the mode button to select the desired mode. On selection the corresponding icon shall be displayed on the LCD display panel.
3. **TEMPERATURE RANGE AND SETTING:** The operating temperature range is 16°C to 30°C (61°F to 86°F), both inclusive. Press the UP or DN button to select the desired temperature. The temperature setting is effective only for the Cool, Heat and Auto modes.
4. **INDOOR (EVAPORATOR) FAN:** There is one indoor fan with single fan speed. When fan speed on LCD panel is HIGH, indoor fan will always turns on. Indoor fan can be set off, when the compressor is cut off by setting the fan speed to AUTO on the LCD panel by pressing Fan button. By pressing the Fan button again the fan speed can resume to HIGH.
5. **COOL MODE:** Whenever the unit is started in cool mode (without Pump Down Solenoid-PDS), the compressors will be turned on one by one depending on the load requirement of the unit.
6. **HEAT MODE (HEATER MODEL):** Whenever the unit is started in heat mode, the heaters shall be switched ON one by one to meet the load requirement.



7. LEAD/LAG OPERATION: Whenever a compressor needs to be on, the controller will turn on the compressor with the shorter accumulated run time provided its 3 minutes minimum off time has lapsed. Otherwise the other compressor will on first. Similarly, the compressor with the longer accumulated run time will be the first one to be cut off. This is to load the compressors evenly over long run period. Balance loading is enabled when compressor #1 lead option is disabled.

8. AUTO MODE: In Auto mode, operating mode will be selected automatically between Heat and Cool mode, depending on the Room Temperature and Set Temperature.

9. ERROR CODE:

Error code is displayed on the LCD panel. When system on and error code is shown, the ON/OFF LED on the LCD panel will blink. When system off, error code is still display for thermistor error but the ON/OFF LED will be off.

E06 Compressor 1 high pressure trip (or contact open)

E07 Compressor 2 high pressure trip (or contact open), (not applicable for single compressor units)

E10 Compressor 1 low pressure trip

E11 Compressor 2 low pressure trip, (not applicable for single compressor units)

CRANKCASE HEATER

The crankcase heater is provided to hold the compressor oil reservoir at higher temperature than the coldest part in the system.

- Power must be supplied to crankcase heater for a minimum of 12-hours prior to system start-up. If power is off for 6-hours or more, crankcase heater must be energized for 12-hours before operating the system. Otherwise compressor damage may result.

PUMP DOWN CONTROL

If the unit is provided with pumpdown system, then a solenoid type valve is installed in the liquid line ahead of expansion valve to prevent flow of refrigerant into the evaporator during off cycle. The controller is wired to solenoid valve which energize in cooling and opening the valve. Whenever the thermostat temperature is satisfied, the solenoid will close followed compressor off after pumping the refrigerant from low side of the system until the low pressure switch open the control circuit.

MAINTENANCE INSTRUCTIONS

AIRFLOW ADJUSTMENT (Applicable for PT075 - PT360 only)

The airflow could be adjusted by adjusting pulleys of blower motor or belt tension with proper mounting and alignment of the pulleys:

- Refer to fan performance tables in the catalog for selecting applicable airflow, RPM and brake horse power at specified static pressure.
- Select the appropriate drive as per motor and blower characteristic in the catalog.
- The set screw shall be loosened to make the pulley moving.
- Adjust pulley's diameter, opening counter clockwise to reduce RPM and further reduce airflow, while closing clockwise increases RPM and airflow.
- Tighten the set screw and then install the belts.
- Test the unit operating airflow for further adjustment.

CRANKCASE HEATER

- Periodic checking for proper operation or crankcase heater is highly recommended as follows:
 - a) Check continuity of the heater using multimeter device.
 - b) Check grounding of the heater by Meggar device (to prevent electrical hazards).
 - c) Observe whether the heater is warming down the compressor near the oil sump.

CLEANING OF COILS & FILTERS

- Turn off the power supply.
- Take out access panel of evaporator coil.
- Remove the filter from its access panel.
- Protect electrical components and motors from water washing.
- Clean the coil by flushing water by pressure washer followed by compressed air from supply to return direction.
- Filter shall be cleaned every six month, in some hygienic application it is recommended for replacement.
- Cleaning drain pan and trap is recommended once in a year to prevent bacteria growing under the coil.

BELT TENSION TESTING PROCEDURE INSTRUCTION (Applicable for PT075 - PT360 only)

To determine the lbs. force required to tension a drive, you simply do the following:

1. Measure the Belt span as shown.
2. Divide belt span by 64 to get belt deflection needed to check tension.
3. Set large "0" ring on span scale at required belt deflection. This scale is in 1/16" increments.
4. Set small "0" ring at zero on the "Force Scale" (plunger).
5. Place the larger end of the tension checker squarely on one belt at the center of the belt span. Apply force on the plunger until the bottom of the large "0" ring is even with the top of the next belt or with the bottom of a straight edge laid across the sheaves.
6. Read the force scale under the small "0" ring to determine force required to give the needed deflection.
7. Compare the force scale reading with the correct value for the belt style and cross section used, as given in table on next page. The force should be between the minimum and maximum values shown.
8. If there is too little deflection force, the belts should be tightened. If there is too much deflection force, the belts should be loosened.

Note: Tension new drives at the maximum deflection force recommended. Check the tension at least two times during the first day's operation as there normally will be a rapid decrease in belt tension until belts have run in. Check the tension periodically after the first day's operation and keep tension in recommended area. The correct operating tension for a V-belt drive is the lowest tension at which the belts will not slip under the peak load conditions. Shafts must be adequate for the tensions required.

BELT TENSION TESTING PROCEDURE

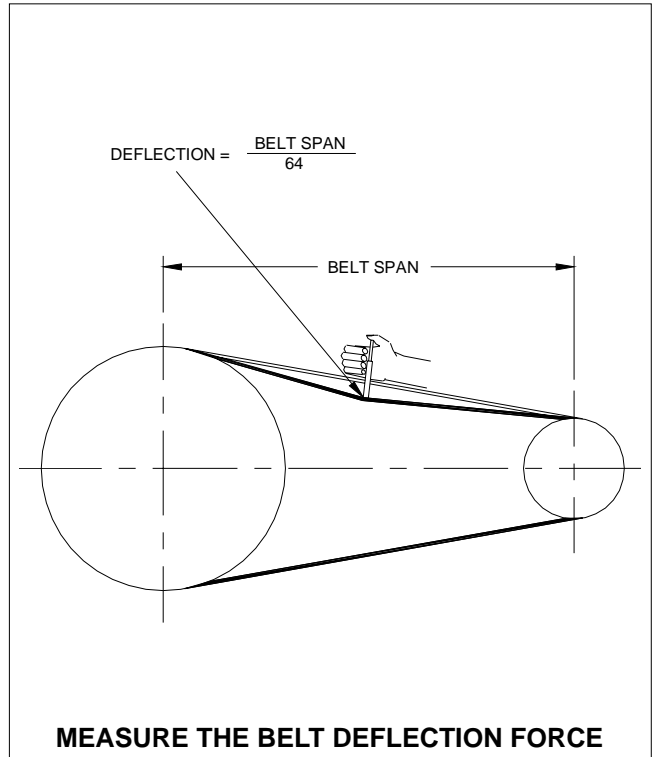
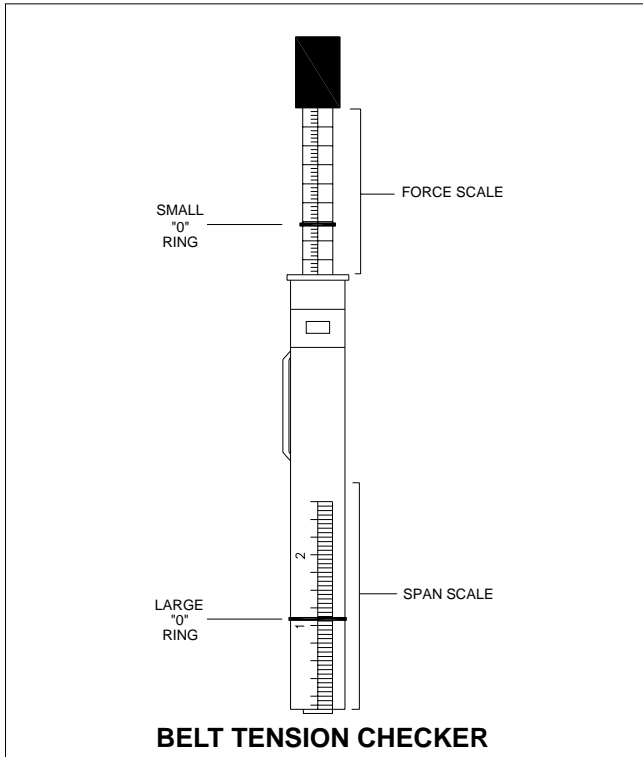

BELTS

BELT TYPE	BELT CROSS SECTION	SMALL PULLEY PITCH DIA. (P.D.) RANGE	DEFLECTION FORCE - LBS.	
			MINIMUM	MAXIMUM
-	3 L	1.25 - 1.75	1/2	5/8
		2 - 2.25	5/8	7/8
		2.5 - 3	3/4	1-1/8
A	4 L	2.1 - 2.8	1-1/8	1-5/8
		3 - 3.5	1-1/2	2-1/8
		3.7 - 5	1-7/8	2-5/8
B	5 L	3 - 4.2	2	2-7/8
		4.5 - 5.2	2-3/8	3-3/8

TYPICAL HIGH AND LOW VOLTAGE FIELD WIRING CONNECTIONS

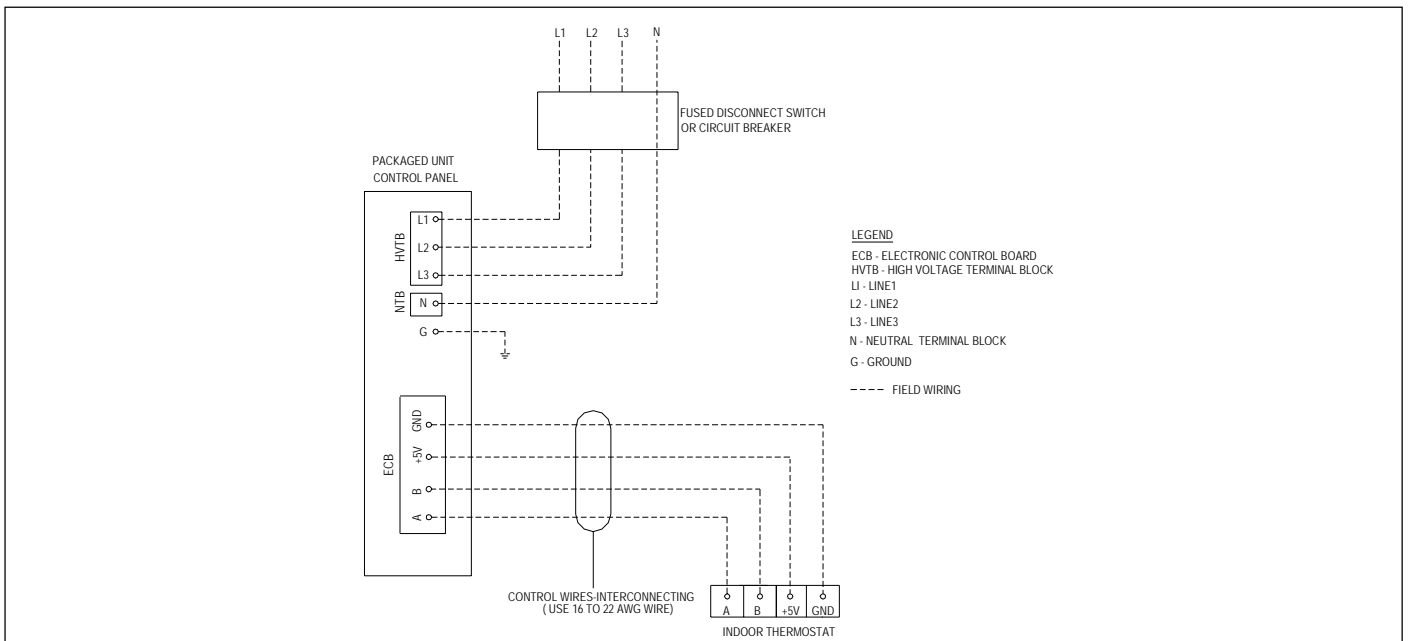

PREVENTIVE MAINTENANCE SCHEDULE



CAUTION: Disconnect power supply and allow all rotating parts to stop before servicing the unit.

I T E M	FREQUENCY OF MAINTENANCE, MONTHS (FIRST 4 YEARS)	
	6	12
Clean air filter (Aluminum)*	X	
Pressure wash condenser & cooling coil as required		X
Check blower belt, tension, wear tear/replace if required	X	
Check alignment of pulleys		X
Clean drain pan, drain pipe		X
Clean blower wheel		X
Check for loose bolts/screws & tighten as necessary		X
Check all electrical controls, components, wiring terminals, etc..., for sparks, over heat, loose connections/repair or correct		X
Check for rusted/paint		X
Check all temperature, pressure readings as applicable and satisfy the operation performance		X
Run test all motors and check the amperage		X
Grease/oil as required		X
Check vibration isolators		X
Clean and fix thermal bulbs in the correct location. Insulate it.		X
Check canvass connections, insulation damage		X

* If fiberglass filters used, replace it yearly.

NOTE: Always observe for abnormal noise or vibration.

MAINTENANCE TOOLS/EQUIPMENT REQUIRED

STANDARD : Screw drivers (Slot & Phillips), adjustable wrenches, pliers, refrigeration wrenches & socket set wrenches, pulley puller, etc.

SPECIAL : Manifold gauge set, R-22 charging cylinder, belt tension checker, leak detector, vacuum pump with electronic gauges, thermometer, hook type ammeter/voltmeter/ohmmeter and oxy-acetylene brazing set etc.

TROUBLE SHOOTING CHART

SYMPTOM	CAUSES	CHECK & CORRECTIVE MEASURE
Thermostat shows no display	<ol style="list-style-type: none"> 1. Power off/Blown fuse 2. Faulty field wiring 3. Loose connections 4. Defective thermostat 	<ol style="list-style-type: none"> 1. Check the power. Switch ON the circuit breaker. Replace fuse if it blown. 2. Check wiring against diagram. 3. Check and correct it. 4. Replace it.
Thermostat LCD panel display is not bright & does not function properly	<ol style="list-style-type: none"> 1. Battery life is over 	<ol style="list-style-type: none"> 1. Replace battery
Blower not running, compressor short cycles	<ol style="list-style-type: none"> 1. Blower belt slipped/not fixed 2. Faulty wiring 3. Burned wiring 4. Defective blower motor contactor 5. Defective blower motor 	<ol style="list-style-type: none"> 1. Correct belt. Check tension and alignment. 2. Check wiring against diagram. 3. Check and correct it. 4. Replace if. 5. Replace it.
Blower running, no sufficient air	<ol style="list-style-type: none"> 1. Wrong rotation (Applicable initial start up/or after a power failure), 3 phase motor 	<ol style="list-style-type: none"> 1. Check the rotation of blower, interchange phase of blower motor from blower motor contactor.
Blower running, but with not enough supply air	<ol style="list-style-type: none"> 1. Loose Belt 2. Variable pulley wide open 3. Return air obstructed 4. High static pressure 5. Improper pulley selection 6. Closed dampers/improper air balance 7. Dirty filter 8. Dirty cooling coil 	<ol style="list-style-type: none"> 1. Adjust it & check belt tension. 2. Adjust the pitch of the pulley. 3. Check and remove the obstructions. 4. Verify static pressure and fan performance data. 5. Change pulley (if blower motor ampere within rated load). 6. Check all dampers opened properly. Balance air. 7. Clean it. 8. Clean it.
Blower running and delivers excess air	<ol style="list-style-type: none"> 1. Variable pulley needs more tightening 2. Improper pulley/motor selection 3. Low external static pressure 	<ol style="list-style-type: none"> 1. Adjust the pitch of the pulley. 2. Select suitable combination. 3. Check the duct design.
Blower runs, compressor not working	<ol style="list-style-type: none"> 1. Safety circuit open due to low suction pressure, high discharge pressure, overload protector 2. Defective compressor contactor 3. Burned wiring 4. Defective compressor 	<ol style="list-style-type: none"> 1. Re-set the unit and determine the reason. Check high & low pressure (refer to symptom for "low/high suction pressure & high discharge pressure"). 2. Replace it. 3. Check and replace it. 4. Replace it.
Compressor runs, but short cycling	<ol style="list-style-type: none"> 1. Safety circuit open due to: <ol style="list-style-type: none"> a) Low suction pressure b) High discharge pressures c) Overload protector 2. Thermostat in cold location 3. High thermostat setting 	<ol style="list-style-type: none"> 1. a) Verify the reason for low suction pressure (refer to symptom for "low suction pressure"). b) Verify the reason for high discharge pressure (refer to symptom for "high discharge pressure"). c) Check dome temperature. RLA each phase. Verify the reason. 2. Check and relocate as required. 3. Lower the temperature setting to 21°C for test.
Thermostat shows faulty indication	<ol style="list-style-type: none"> 1. Safety circuit open due to: <ol style="list-style-type: none"> a) Low pressure switch b) High pressure switch c) Overload protector 	<ol style="list-style-type: none"> 1. a) Verify the reason & correct it (refer to symptom for "low suction pressure"). b) Verify the reason for high discharge pressure. (refer to symptom for "high discharge pressure"). c) Check comp. RLA against nameplate for each phase, check comp. dome temperature, etc. & correct it.
Low suction pressure	<ol style="list-style-type: none"> 1. Less Freon 2. Loose belt 3. Variable pulley widely open 4. Dirty filter 5. Dirty cooling coil 6. Return air restricted 7. Improper expansion valve bulb installation/location 8. Restriction in expansion valve/filter dryer 	<ol style="list-style-type: none"> 1. Check for gas leak & charge freon as required. 2. Adjust it. Check belt tension. 3. Adjust the pulley. 4. Clean it. 5. Clean it. 6. Check return air grille sizes, etc. against design. 7. Verify and correct it. 8. Check and correct/replace it.
High suction pressure	<ol style="list-style-type: none"> 1. Excess freon charge 2. Excess air quantity 3. High room temperature condition 4. Undersize unit (serving large area) 5. Expansion valve widely open 6. Defective compressor valve 	<ol style="list-style-type: none"> 1. Verify and adjust it. 2. Adjust air quantity. 3. Check & verify. Isolate the area to be cooled & observe. 4. Check design/unit selection. 5. Check superheat & adjust it, if required. 6. Check and replace compressor.
High discharge pressure	<ol style="list-style-type: none"> 1. Condenser fan motor not working properly 2. Excess freon charge 3. Dirty condenser 4. High ambient condition/Air in condenser obstructed 5. Defective fan motor capacitor 6. Defective fan motor 	<ol style="list-style-type: none"> 1. Fan blade stuck with ventury. Check & correct it. 2. Check freon and adjust it, if necessary. 3. Clean it. 4. Verify the reason and correct it. 5. Check and replace it. 6. Check and replace it.

TROUBLE SHOOTING CHART

SYMPTOM	CAUSES	CHECK & CORRECTIVE MEASURE
Unit works continuously, no sufficient cooling	<ol style="list-style-type: none"> 1. Low suction pressure 2. High discharge pressure 3. Less air quantity 4. Cooling coil ices up 5. Second stage (If exists) not working 6. Serving large area 	<ol style="list-style-type: none"> 1. Verify the reason & correct it (refer to symptom for "low suction pressure"). 2. Verify the reason and adjust the freon, if required.(refer to symptom for "high discharge pressure"). 3. Refer to symptom for "blower works, less air". 4. Determine the reason (refer to symptom for "cooling coil ice up") & correct it. 5. Set the thermostat to lower temperature (21°C)/ or verify the reason. 6. Check the design.
Unit not cooling properly during night time	<ol style="list-style-type: none"> 1. Low ambient condition 2. Safety low pressure switch open due to low suction pressure 3. Fan cycling (whenever applicable) setting low 4. Thermostat setting too low 5. Cooling coil ices-up 6. Less air quantity 	<ol style="list-style-type: none"> 1. Check and verify the ambient temperature. 2. Check the reason and correct it (refer to symptom for "low suction pressure"). 3. Adjust the fan cycling. 4. Adjust the thermostat setting. 5. Verify the reason and correct it (refer to symptom for "cooling coil ice up"). 6. Verify the reason and correct it (refer to symptom for "blower works, less air").
Not sufficiently cooling during daytime	<ol style="list-style-type: none"> 1. High discharge pressure 2. High thermostat setting 3. Serving large area 4. Less air quantity 5. High ambient condition 6. Dirty condenser 	<ol style="list-style-type: none"> 1. Check and verify the reason (refer to symptom for "high discharge pressure"). 2. Adjust thermostat. 3. Check the design/unit selection. 4. Check and verify the reason (refer to symptom for "blower works, less air"). 5. Check the ambient condition. 6. Clean it.
Cooling coil ices up	<ol style="list-style-type: none"> 1. Less freon 2. Less air quantity 3. Dirty filter 4. Dirty cooling coil 	<ol style="list-style-type: none"> 1. Check for gas leak & charge freon as required. 2. Determine the reason and correct it (refer to symptom for "blower works, less air"). 3. Clean it. 4. Clean it.
Unit is not restarting (after a cut-off)	<ol style="list-style-type: none"> 1. Safety circuit open due to low pressure switch 	<ol style="list-style-type: none"> 1. Rectify the reason of low suction pressure (refer to symptom for "low suction pressure").
Unit is taking long time to restart	<ol style="list-style-type: none"> 1. Thermostat in cold location 	<ol style="list-style-type: none"> 1. Shift the location as required.
Compressor goes lockout (pump down system)	<ol style="list-style-type: none"> 1. Imbalance freon 2. Malfunctioning pumpdown solenoid valve 	<ol style="list-style-type: none"> 1. Check freon charge and confirm FLA. 2. Check pumpdown solenoid valve operation.
Taking more time for the pumpdown cycle, cooling coil ices up	<ol style="list-style-type: none"> 1. Leaky pumpdown solenoid valve 	<ol style="list-style-type: none"> 1. Check pumpdown solenoid valve and replace it.
Noisy unit	<ol style="list-style-type: none"> 1. Improper installation 2. Improper vibration isolators 3. Loose parts or mountings 4. Tubing rattle 5. Bent fan blade causes vibration 6. Defective bearings 7. Belt tension is high 8. Blower motor pulley is not aligned 	<ol style="list-style-type: none"> 1. Check and correct it properly. 2. Check and correct it properly. 3. Check and tighten. 4. Tighten the pipe support. 5. Check the balance, alignment, bracket, etc. Correct it/replace it. 6. Replace the motor. 7. Adjust belt tension. 8. Align pulley.
Unit operational noise listening inside the building	<ol style="list-style-type: none"> 1. Improper installation 2. Improper vibration isolators 3. Abnormal noise in the unit 4. Unit too close to the slab/wall openings 5. Duct design (high static) 6. Wooden packing beneath the compressor is not removed 	<ol style="list-style-type: none"> 1. Check and correct it. 2. Check and correct it. 3. Verify the reason of noisy unit & correct it. 4. Verify the design/Relocate the unit if necessary. 5. Check & verify the design. 6. Remove wooden packing (if any).
Compressor not working	<ol style="list-style-type: none"> 1. Low voltage 2. Single phase failure 3. Burned wirings 4. Overload protector open 5. Defective contactor 6. Burned compressor motor winding 7. Damaged (stuck) compressor 	<ol style="list-style-type: none"> 1. Rectify the reason & correct it. 2. Check the compressor amperage each phase. 3. Check and correct it. 4. Check and verify the reason. 5. Check and replace it. 6. Check and replace it. 7. Check and replace it.
Circuit breaker of the unit trips	<ol style="list-style-type: none"> 1. Burned wirings 2. Grounded wirings 3. Faulty field wiring 4. Grounded compressor/blower motor 5. Undersize circuit breaker 	<ol style="list-style-type: none"> 1. Check and correct the wiring. 2. Check meggar test. 3. Check wiring against diagram. 4. Replace it, if required. 5. Check the circuit breaker ratings.

TYPICAL SCHEMATIC WIRING DIAGRAM

MODELS : PT036 - PT075 (Single compressor units)

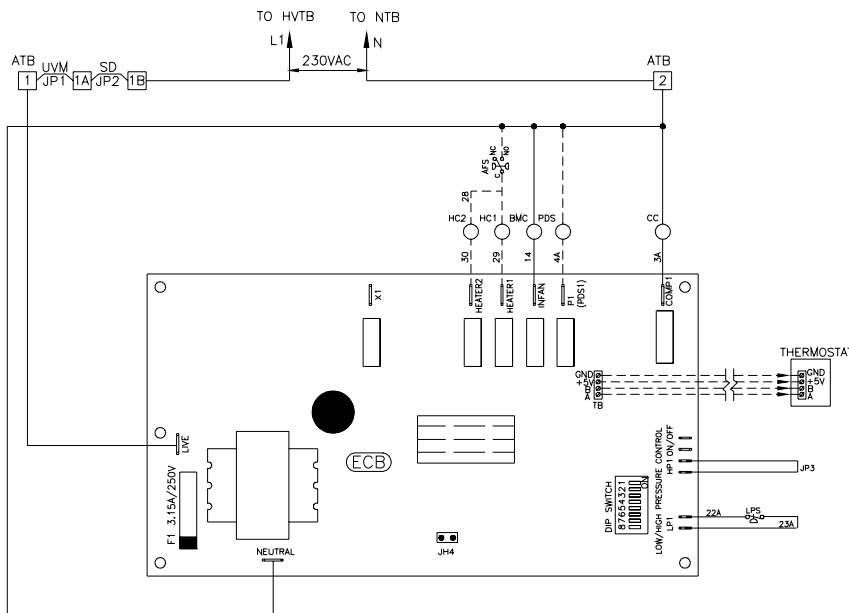
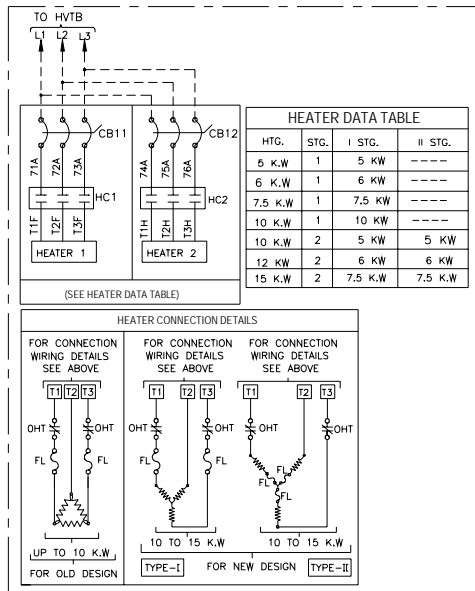
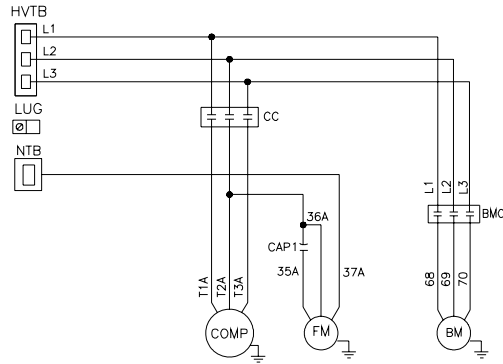

DIP SWITCH SETTINGS		
S1	OFF=COOLING/HEATING MODE	ON= NOT USED
S2	OFF=WITHOUT PDS	ON=WITH PDS
S3,S4		OFF,OFF=NO HEATER OFF,ON=ONE HEATER ON,ON=TWO HEATER
S5	OFF=NOT USED	ON=LCD PANEL SENSOR CONTROL
S6	OFF=1.0 STAGE DIFFERENTIAL TEMP.	ON=1.5 STAGE DIFFERENTIAL TEMP.
S7	OFF=WITHOUT AUTO MODE	ON=WITH AUTO MODE
S8	OFF=NOT USED	ON=NOT USED
FACTORY SETTING OF S1, S5, S6 & S7		
S1 - OFF, S5 - ON, S6 - OFF, S7 - OFF		
JUMPER SETTING ON ECB		
1, JH4 (TEST) - OPEN: TEST RUN DISABLE (FACTORY SETTING) - CLOSE: TEST RUN ENABLE		

NOTE: 1. Refer to next page for legend, notes & wiring diagram for optional items.
2. Refer to unit control box (inside panel) for exact wiring diagram.

TYPICAL SCHEMATIC WIRING DIAGRAM

MODELS : PT036 - PT075 (Single compressor units)

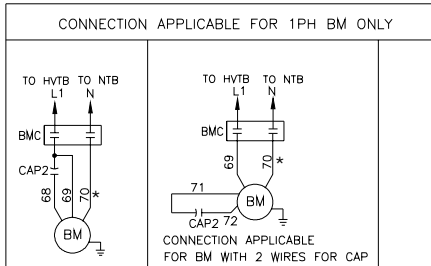

PLS. REFER MOTOR NAMEPLATE FOR POWER & CAPACITOR CONNECTIONS

* FACTORY INSTALLED B.M SPEED

MODEL	WIRE COLOUR
PT 036	ORANGE
PT 048	PURPLE
PT 060	BLUE

NOTE
OPTIONAL SPEED WIRES TO BE TERMINATED WITH SPLICE OR DISCONNECT TAB 1/4"

CONNECTION APPLICABLE FOR BM WITH EXTERNAL OLR

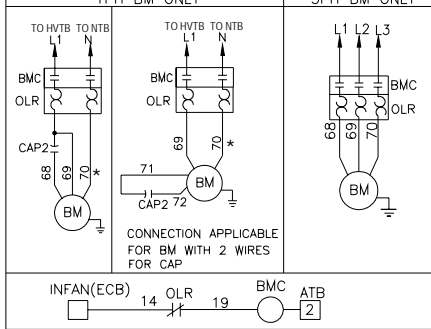

PRESSURE SWITCH SETTINGS

NAME	OPEN (PSIG)	CLOSE (PSIG)
LPS	25 ± 5	50 ± 5
HPS	450 ± 10	360 ± 15

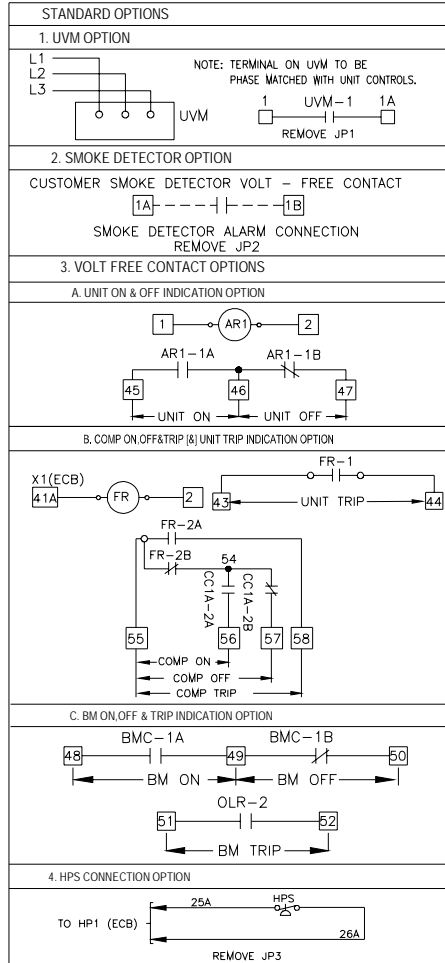
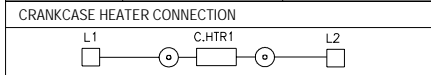

LEGEND	
AR	AUXILIARY RELAY
AFS	AIRFLOW SWITCH
ATB	AUXILIARY TERMINAL BLOCK
BM	BLOWER MOTOR
BMC	BLOWER MOTOR CONTACTOR
CC	COMPRESSOR CONTACTOR
CCA	AUXILIARY CONTACT
CB	CIRCUIT BREAKER
C. HTR	CRANKCASE HEATER
COMP	COMPRESSOR
ECB	ELECTRONIC CONTROL BOARD
FCS	FAN CYCLING SWITCH
F	FUSE
FL	FUSE LINK
FM	FAN MOTOR (CONDENSER)
FMC	FAN MOTOR CONTACTOR
FR	FAULT RELAY
HC	HEATER CONTACTOR
HPS	HIGH PRESSURE SWITCH
HVTB	HIGH VOLTAGE TERMINAL BLOCK
HTR	HEATER
JP	JUMPER
L1	LINE 1
L2	LINE 2
L3	LINE 3
LPS	LOW PRESSURE SWITCH
LUG	LUG GROUND
NTB	NEUTRAL TERMINAL BLOCK
O/L	OVER LOAD
OHT	OVER HEAT THERMOSTAT
PDS	PUMP DOWN SOLENOID
SSPS	SOLID STATE PROTECTIVE SYSTEM
SD	SMOKE DETECTOR
TRANS	TRANSFORMER
TSTAT	THERMOSTAT
UVM	UNDER VOLTAGE MONITOR
- - -	FIELD WIRING
+	DISCONNECT TAB - 1/4"
⊙	SPLICE-CLOSED END
□	TERMINAL BLOCK OR TERMINATION POINT

- NOTES
- POWER SUPPLY, 380/415V-3PH-50Hz.
 - ANY WIRE REPLACEMENT SHOULD BE OF 90°C OR ITS EQUIVALENT. USE COPPER CONDUCTOR WIRES ONLY.
 - IF PDS & HEATERS ARE FACTORY INSTALLED, PLEASE READ BROKEN LINES AS CONTINUOUS LINES.
 - POWER MUST BE SUPPLIED TO CRANKCASE HEATER FOR MINIMUM OF 12 HOURS PRIOR TO SYSTEM START UP. IF POWER IS OFF 6 HOURS OR MORE, CRANKCASE HEATER MUST BE ON FOR 12 HOURS BEFORE OPERATING THE SYSTEM.

FAILURE TO FOLLOW THESE INSTRUCTIONS MAY RESULT IN COMPRESSOR DAMAGE.
 - FUSED DISCONNECT SWITCH OR CIRCUIT BREAKER TO BE PROVIDED BY CONSUMER WITH RATING AS RECOMMENDED BY COOLINE.
 - COMPRESSOR IS PROVIDED WITH INTERNAL OVERLOAD.
 - IF ANY CHANGE IN DIP SWITCH SETTING IS REQUIRED, TURN OFF POWER FIRST & SET REQUIRED SETTING.

TYPICAL SCHEMATIC WIRING DIAGRAM

MODELS : PT090 - PT120 (Dual compressor units)

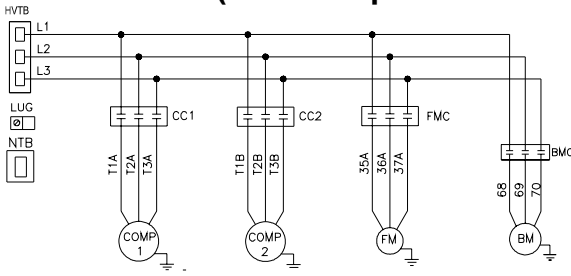

(SEE HEATER DATA TABLE)

HTG.	STG.	I STG.	II STG.
5 K.W	1	5 KW	----
6 K.W	1	6 KW	----
7.5 K.W	1	7.5 KW	----
10 K.W	1	10 KW	----
10 K.W	2	5 KW	5 KW
12 K.W	2	6 KW	6 KW
15 K.W	2	7.5 K.W	7.5 K.W
20 K.W	2	10 K.W	10 K.W
25 K.W	2	12.5 K.W	12.5 K.W
30 K.W	2	15 K.W	15 K.W

HEATER CONNECTION DETAILS

FOR CONNECTION WIRING DETAILS SEE ABOVE

UP TO 10 K.W
FOR OLD DESIGN

FOR CONNECTION WIRING DETAILS SEE ABOVE

10 TO 15 K.W
TYPE-II FOR NEW DESIGN

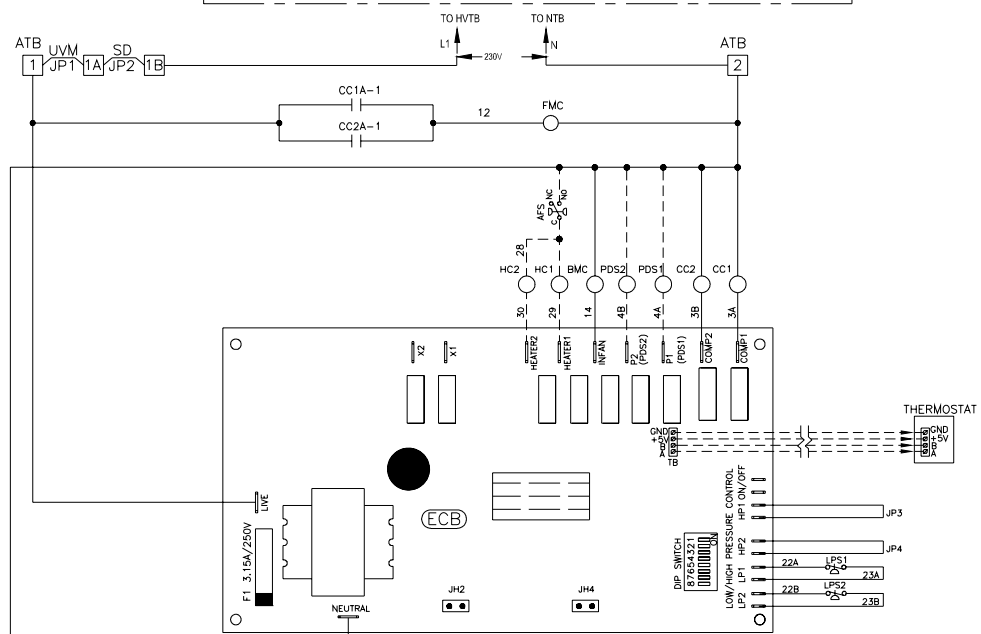

NOTE: 1. Refer to next page for legend, notes & wiring diagram for optional items.
2. Refer to unit control box (inside panel) for exact wiring diagram.

TYPICAL SCHEMATIC WIRING DIAGRAM

MODELS : PT090 - PT120 (Dual compressor units)

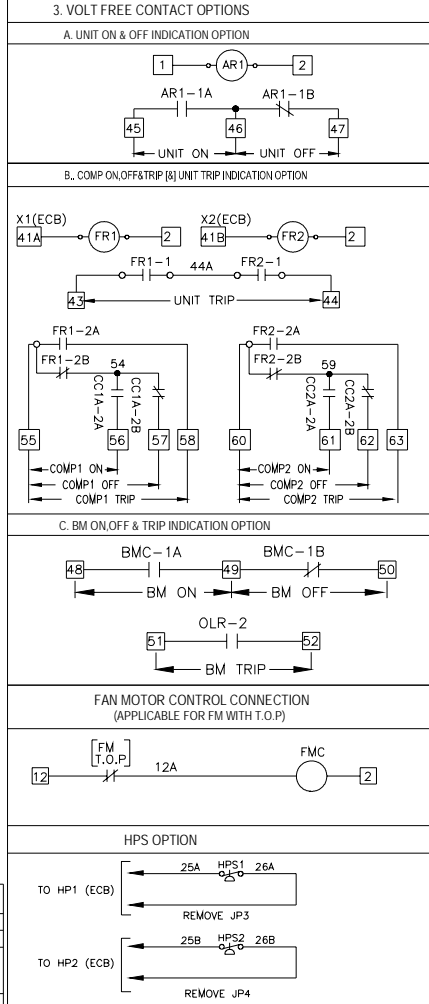
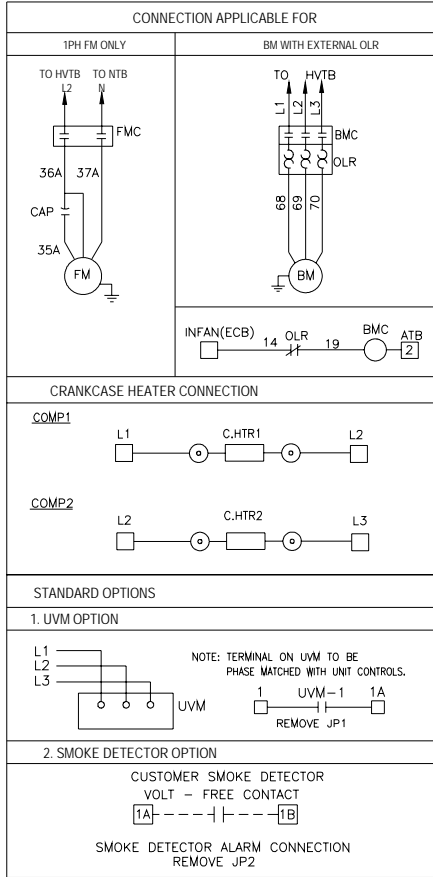

LEGEND	
AR	AUXILIARY RELAY
AFS	AIRFLOW SWITCH
ATB	AUXILIARY TERMINAL BLOCK
BM	BLOWER MOTOR
BMC	BLOWER MOTOR CONTACTOR
CC	COMPRESSOR CONTACTOR
CCA	AUXILIARY CONTACT
CB	CIRCUIT BREAKER
C. HTR	CRANKCASE HEATER
COMP	COMPRESSOR
ECB	ELECTRONIC CONTROL BOARD
FCS	FAN CYCLING SWITCH
F	FUSE
FL	FUSE LINK
FM	FAN MOTOR (CONDENSER)
FMC	FAN MOTOR CONTACTOR
FR	FAULT RELAY
HC	HEATER CONTACTOR
HPS	HIGH PRESSURE SWITCH
HVTB	HIGH VOLTAGE TERMINAL BLOCK
HTR	HEATER
JP	JUMPER
L1	LINE 1
L2	LINE 2
L3	LINE 3
LPS	LOW PRESSURE SWITCH
LUG	LUG GROUND
NTB	NEUTRAL TERMINAL BLOCK
O/L	OVER LOAD
OHT	OVER HEAT THERMOSTAT
PDS	PUMP DOWN SOLENOID
SSPS	SOLID STATE PROTECTIVE SYSTEM
SD	SMOKE DETECTOR
TRANS	TRANSFORMER
TSTAT	THERMOSTAT
UVM	UNDER VOLTAGE MONITOR
- - -	FIELD WIRING
+	DISCONNECT TAB - 1/4"
⊙	SPLICE-CLOSED END
□	TERMINAL BLOCK OR TERMINATION POINT

DIP SWITCH SETTINGS	
S1 OFF=COOLING/HEATING MODE	ON= NOT USED
S2 OFF=WITHOUT PDS	ON=WITH PDS
S3,S4	OFF,OFF=NO HEATER OFF,ON=ONE HEATER ON,ON=TWO HEATER
S5 OFF=NOT USED	ON=LCD PANEL SENSOR CONTROL
S6 OFF=1.0 STAGE DIFFERENTIAL TEMP.	ON=1.5 STAGE DIFFERENTIAL TEMP.
S7 OFF=WITHOUT AUTO MODE	ON=WITH AUTO MODE
S8 OFF=NOT USED	ON=NOT USED
FACTORY SETTING OF S1, S5, S6 & S7	
S1 - OFF, S5 - ON, S6 - OFF, S7 - OFF	

PRESSURE SWITCH SETTINGS		
NAME	OPEN (PSIG)	CLOSE (PSIG)
LPS1 & 2	25 ± 5	50 ± 5
HPS1 & 2	450 ± 10	360 ± 15

JUMPER SETTING ON ECB	
1. JH2 (COMP1 LEAD) - OPEN: COMP1 LEAD - CLOSE: AUTO LEAD/LAG (FACTORY SETTING)	
2. JH4 (TEST) - OPEN: TEST RUN DISABLE (FACTORY SETTING) - CLOSE: TEST RUN ENABLE	

NOTES

- POWER SUPPLY, 380/415V-3PH-50HZ.
 - ANY WIRE REPLACEMENT SHOULD BE OF 90°C OR ITS EQUIVALENT. USE COPPER CONDUCTOR WIRES ONLY.
 - IF PDS & HEATERS ARE FACTORY INSTALLED, PLEASE READ BROKEN LINES AS CONTINUOUS LINES.
 - POWER MUST BE SUPPLIED TO CRANKCASE HEATER FOR MINIMUM OF 12 HOURS PRIOR TO SYSTEM START UP. IF POWER IS OFF 6 HOURS OR MORE, CRANKCASE HEATER MUST BE ON FOR 12 HOURS BEFORE OPERATING THE SYSTEM.
- FAILURE TO FOLLOW THESE INSTRUCTIONS MAY RESULT IN COMPRESSOR DAMAGE.
- FUSED DISCONNECT SWITCH OR CIRCUIT BREAKER TO BE PROVIDED BY CONSUMER WITH RATING AS RECOMMENDED BY COOLINE.
 - COMPRESSORS ARE PROVIDED WITH INTERNAL OVERLOAD.
 - IF ANY CHANGE IN DIP SWITCH SETTING IS REQUIRED, TURN OFF POWER FIRST & SET REQUIRED SETTING.

TYPICAL SCHEMATIC WIRING DIAGRAM

MODELS : PT180 - PT240 (Dual compressor units)

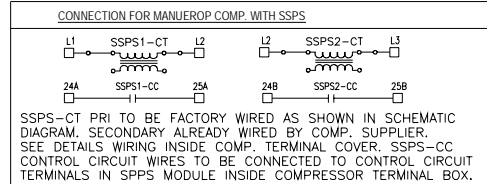
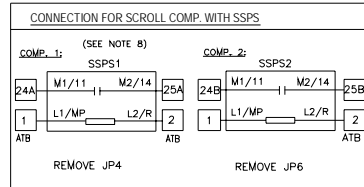
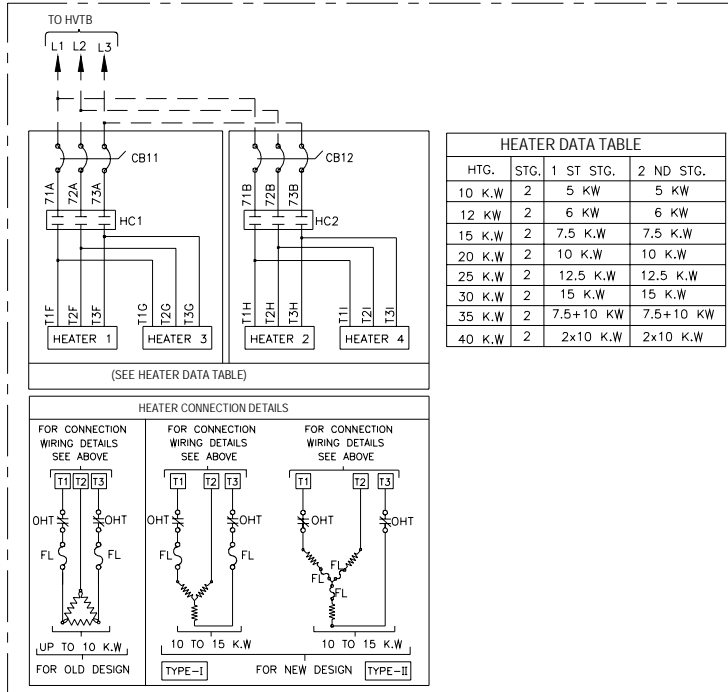
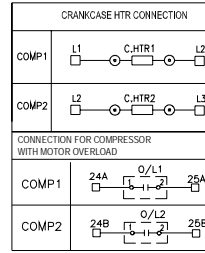
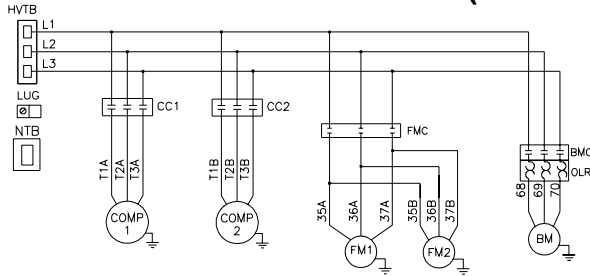

DIP SWITCH SETTINGS

S1	OFF=COOLING/HEATING MODE	ON= NOT USED
S2	OFF=WITHOUT PDS	ON=WITH PDS
S3,S4		OFF,OFF=NO HEATER OFF,ON=ONE HEATER ON,ON=TWO HEATER
S5	OFF=NOT USED	ON=LCD PANEL SENSOR CONTROL
S6	OFF=1.0 STAGE DIFFERENTIAL TEMP.	ON=1.5 STAGE DIFFERENTIAL TEMP.
S7	OFF=WITHOUT AUTO MODE	ON=WITH AUTO MODE
S8	OFF=NOT USED	ON=NOT USED

FACTORY SETTING OF S1, S5, S6 & S7

S1 - OFF, S5 - ON, S6 - OFF, S7 - OFF

JUMPER SETTING ON ECB

- JH2 (COMP1 LEAD) - OPEN: COMP1 LEAD - CLOSE: AUTO LEAD/LAG (FACTORY SETTING)
- JH4 (TEST) - OPEN: TEST RUN DISABLE (FACTORY SETTING) - CLOSE: TEST RUN ENABLE

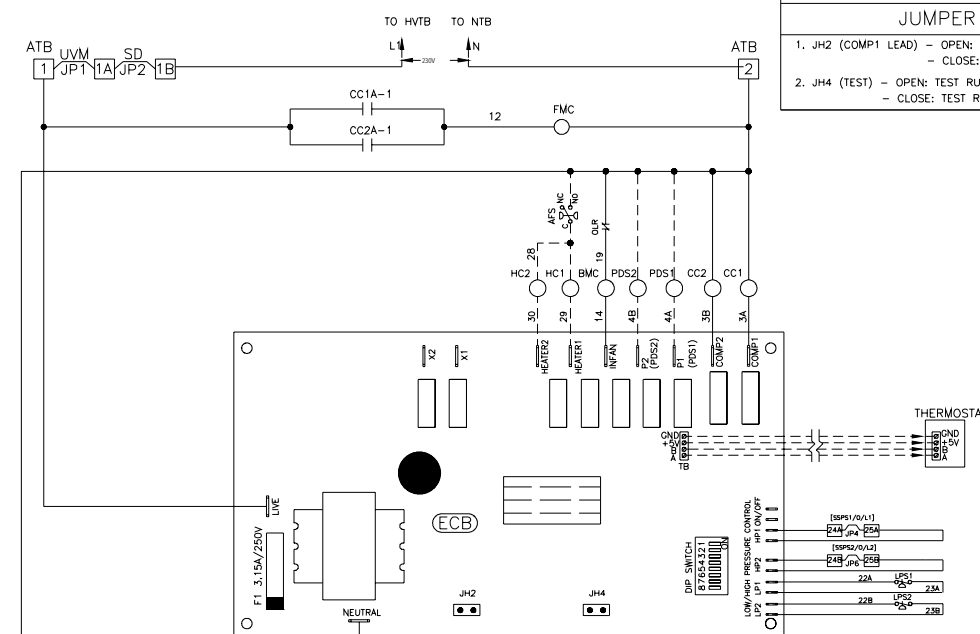

NOTE: 1. Refer to next page for legend, notes & wiring diagram for optional items.
2. Refer to unit control box (inside panel) for exact wiring diagram.

TYPICAL SCHEMATIC WIRING DIAGRAM

MODELS : PT180 - PT240 (Dual compressor units)

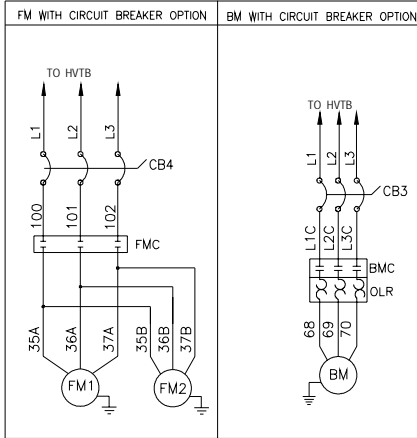

COMP. WITH CIRCUIT BREAKER OPTION

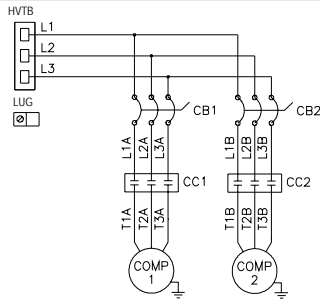

LOW AMBIENT OPTION

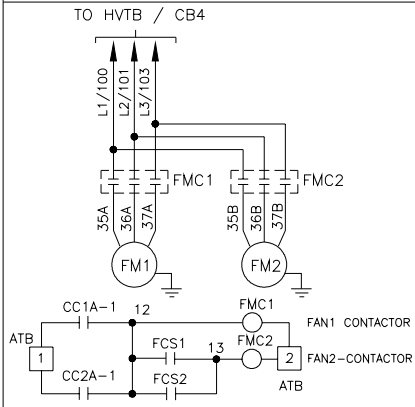

PRESSURE SWITCH SETTINGS		
NAME	OPEN (PSIG)	CLOSE (PSIG)
LPS1 & 2	25 ± 5	50 ± 5
HPS1 & 2	450 ± 10	360 ± 15
FCS1 & 2	190 ± 15	290 ± 10

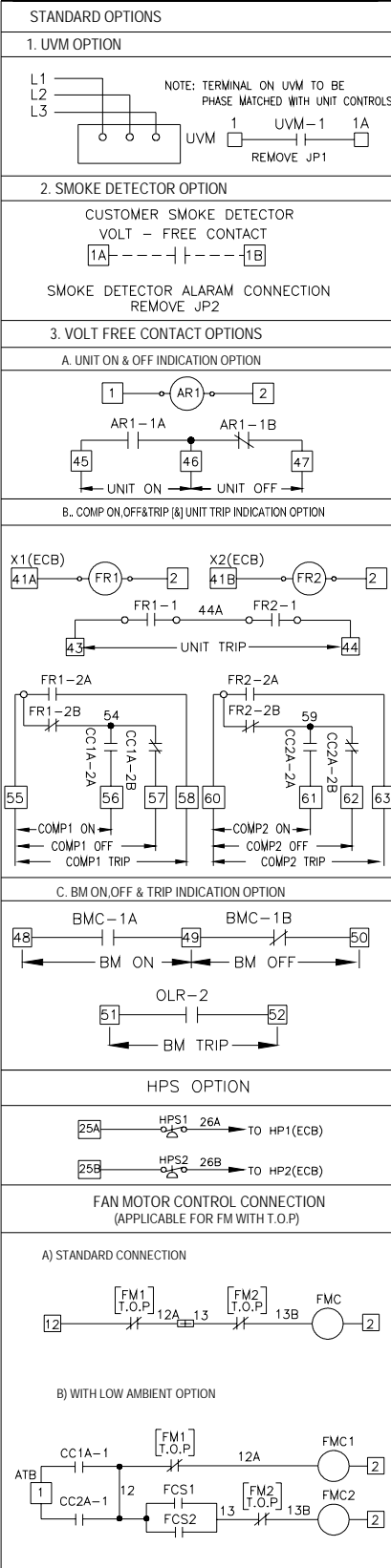

LEGEND	
AR	AUXILIARY RELAY
AFS	AIRFLOW SWITCH
ATB	AUXILIARY TERMINAL BLOCK
BM	BLOWER MOTOR
BMC	BLOWER MOTOR CONTACTOR
CC	COMPRESSOR CONTACTOR
CCA	AUXILIARY CONTACT
CB	CIRCUIT BREAKER
C. HTR	CRANKCASE HEATER
COMP	COMPRESSOR
ECB	ELECTRONIC CONTROL BOARD
FCS	FAN CYCLING SWITCH
F	FUSE
FL	FUSE LINK
FM	FAN MOTOR (CONDENSER)
FMC	FAN MOTOR CONTACTOR
FR	FAULT RELAY
HC	HEATER CONTACTOR
HPS	HIGH PRESSURE SWITCH
HVTB	HIGH VOLTAGE TERMINAL BLOCK
HTR	HEATER
JP	JUMPER
L1	LINE 1
L2	LINE 2
L3	LINE 3
LPS	LOW PRESSURE SWITCH
LUG	LUG GROUND
NTB	NEUTRAL TERMINAL BLOCK
O/L	OVER LOAD
OHT	OVER HEAT THERMOSTAT
PDS	PUMP DOWN SOLENOID
SSPS	SOLID STATE PROTECTIVE SYSTEM
SD	SMOKE DETECTOR
TRANS	TRANSFORMER
TSTAT	THERMOSTAT
UVM	UNDER VOLTAGE MONITOR
---	FIELD WIRING
+	DISCONNECT TAB - 1/4"
⊙	SPLICE-CLOSED END
□	TERMINAL BLOCK OR TERMINATION POINT

NOTES

- POWER SUPPLY, 380/415V-3PH-50HZ.
- ANY WIRE REPLACEMENT SHOULD BE OF 90°C OR ITS EQUIVALENT. USE COPPER CONDUCTOR WIRES ONLY.
- IF PDS & HEATERS ARE FACTORY INSTALLED, PLEASE READ BROKEN LINES AS CONTINUOUS LINES.
- POWER MUST BE SUPPLIED TO CRANKCASE HEATER FOR MINIMUM OF 12 HOURS PRIOR TO SYSTEM START UP. IF POWER IS OFF 6 HOURS OR MORE, CRANKCASE HEATER MUST BE ON FOR 12 HOURS BEFORE OPERATING THE SYSTEM.
- FAILURE TO FOLLOW THESE INSTRUCTIONS MAY RESULT IN COMPRESSOR DAMAGE.
- FUSED DISCONNECT SWITCH OR CIRCUIT BREAKER TO BE PROVIDED BY CONSUMER WITH RATING AS RECOMMENDED BY COOLINE.
- COMPRESSORS ARE PROVIDED WITH INTERNAL OVERLOAD.
- IF COMPRESSOR IS SUPPLIED WITH SSPS, CONNECT AS SHOWN. PLEASE ALLOW 2-3 MINUTES FOR SSPS SWITCH TO CLOSE, BEFORE STARTING THE UNIT.
- IF ANY CHANGE IN DIP SWITCH SETTING IS REQUIRED, TURN OFF POWER FIRST & SET REQUIRED SETTING.

TYPICAL SCHEMATIC WIRING DIAGRAM

MODELS : PT300 - PT360 (Dual compressor units)

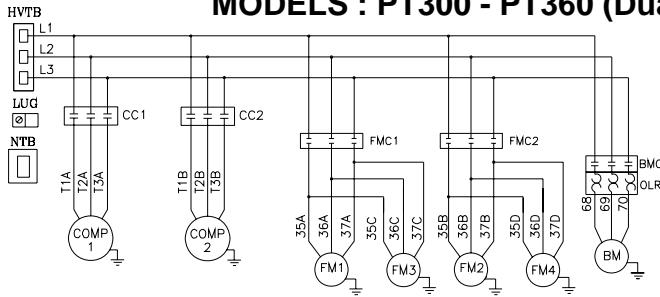

CRANKCASE HTR CONNECTION

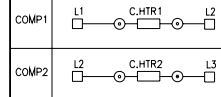

CONNECTION FOR COMPRESSOR WITH MOTOR OVERLOAD

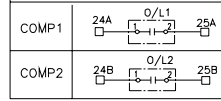

CONNECTION FOR SCROLL COMP. WITH SSPS

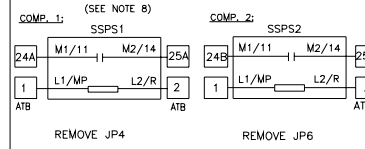

CONNECTION FOR MANUEROP COMP. WITH SSPS

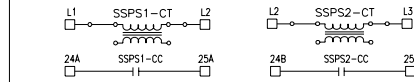

SSPS-CT PRI TO BE FACTORY WIRED AS SHOWN IN SCHEMATIC DIAGRAM. SECONDARY ALREADY WIRED BY COMP. SUPPLIER. SEE DETAILS WIRING INSIDE COMP. TERMINAL COVER. SSPS-CC CONTROL CIRCUIT WIRES TO BE CONNECTED TO CONTROL CIRCUIT TERMINALS IN SSPS MODULE INSIDE COMPRESSOR TERMINAL BOX.

HEATER DATA TABLE

HTG.	STG.	1 ST STG.	2 ND STG.
10 K.W	2	5 KW	5 KW
12 K.W	2	6 KW	6 KW
15 K.W	2	7.5 K.W	7.5 K.W
20 K.W	2	10 K.W	10 K.W
25 K.W	2	12.5 K.W	12.5 K.W
30 K.W	2	15 K.W	15 K.W
35 K.W	2	7.5+10 KW	7.5+10 KW
40 K.W	2	2x10 K.W	2x10 K.W

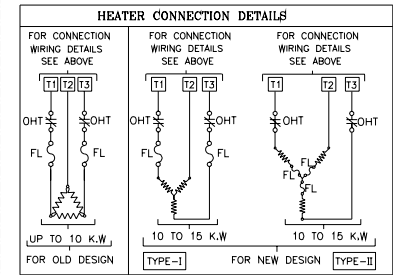
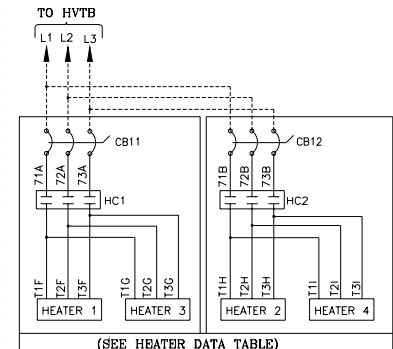

DIP SWITCH SETTINGS

S1	OFF=COOLING/HEATING MODE	ON= NOT USED
S2	OFF=WITHOUT PDS	ON=WITH PDS
S3,S4	OFF=OFF-NO HEATER	OFF,ON=ONE HEATER
		ON,ON=TWO HEATER
S5	OFF=NOT USED	ON=LCD PANEL SENSOR CONTROL
S6	OFF=1.0 STAGE DIFFERENTIAL TEMP.	ON=1.5 STAGE DIFFERENTIAL TEMP.
S7	OFF=WITHOUT AUTO MODE	ON=WITH AUTO MODE
S8	OFF=NOT USED	ON=NOT USED

FACTORY SETTING OF S1, S5, S6 & S7

S1 - OFF, S5 - ON, S6 - OFF, S7 - OFF

JUMPER SETTING ON ECB

- JH2 (COMP1 LEAD) - OPEN: COMP1 LEAD - CLOSE: AUTO LEAD/LAG (FACTORY SETTING)
- JH4 (TEST) - OPEN: TEST RUN DISABLE (FACTORY SETTING) - CLOSE: TEST RUN ENABLE

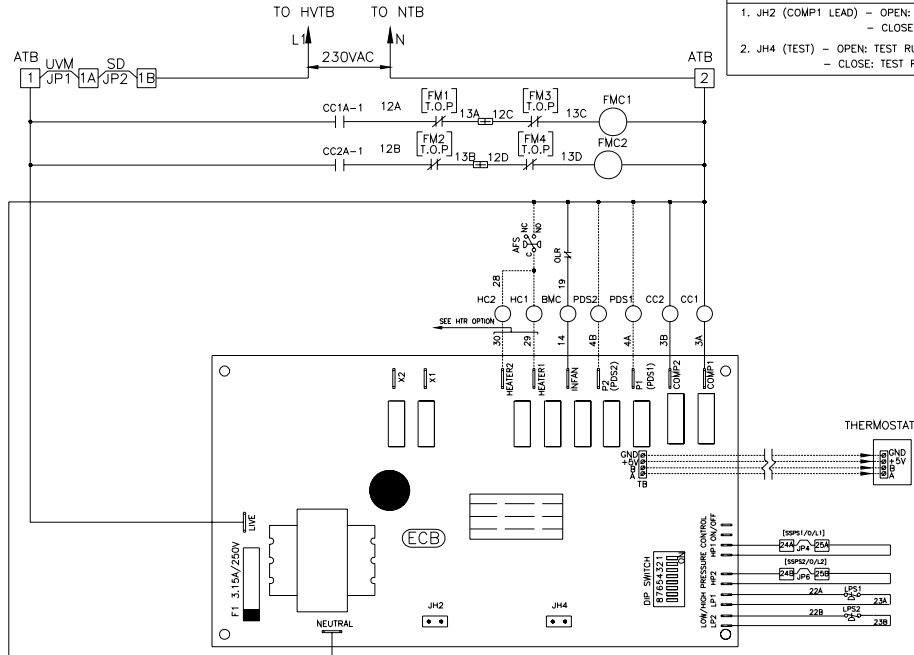

NOTE: 1. Refer to next page for legend, notes & wiring diagram for optional items.
2. Refer to unit control box (inside panel) for exact wiring diagram.

TYPICAL SCHEMATIC WIRING DIAGRAM

MODELS : PT300 - PT360 (Dual compressor units)

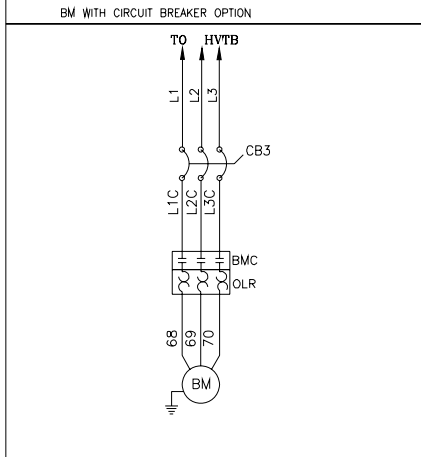
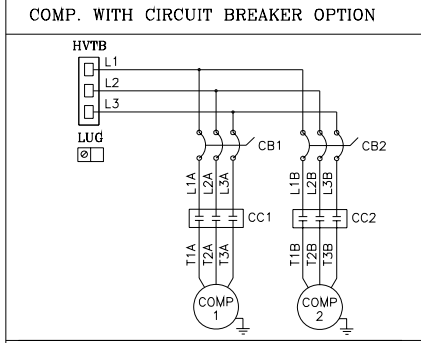
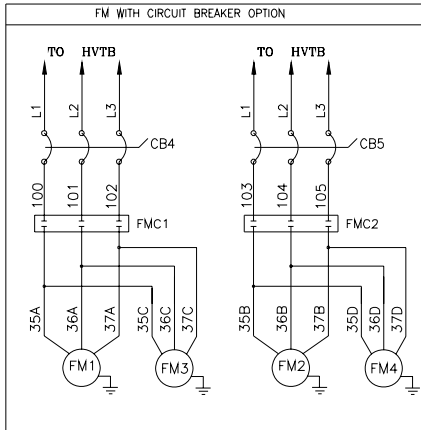

PRESSURE SWITCH SETTINGS		
NAME	OPEN (PSIG)	CLOSE (PSIG)
LPS1 & 2	25 ± 5	50 ± 5
HPS1 & 2	450 ± 10	360 ± 15

STANDARD OPTIONS

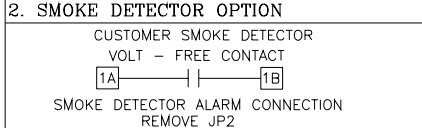
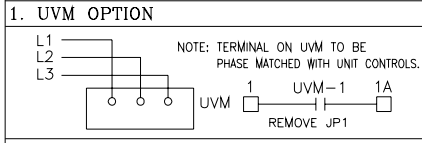

3. VOLT FREE CONTACT OPTIONS

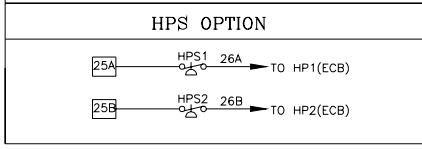
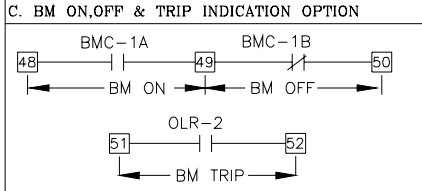
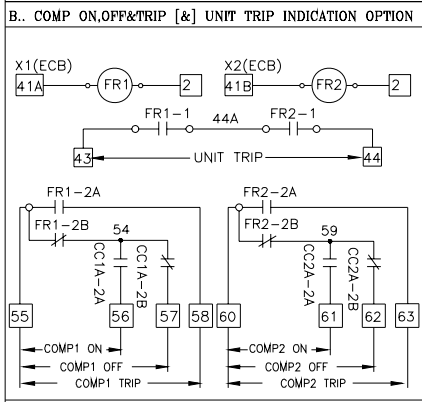
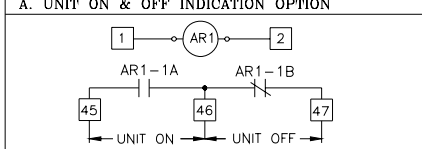

LEGEND

AR	AUXILIARY RELAY
AFS	AIRFLOW SWITCH
ATB	AUXILIARY TERMINAL BLOCK
BM	BLOWER MOTOR
BMC	BLOWER MOTOR CONTACTOR
CC	COMPRESSOR CONTACTOR
CCA	AUXILIARY CONTACT
CB	CIRCUIT BREAKER
C. HTR	CRANKCASE HEATER
COMP	COMPRESSOR
ECB	ELECTRONIC CONTROL BOARD
FCS	FAN CYCLING SWITCH
F	FUSE
FL	FUSE LINK
FM	FAN MOTOR (CONDENSER)
FMC	FAN MOTOR CONTACTOR
FR	FAULT RELAY
HC	HEATER CONTACTOR
HPS	HIGH PRESSURE SWITCH
HVTB	HIGH VOLTAGE TERMINAL BLOCK
HTR	HEATER
JP	JUMPER
L1	LINE 1
L2	LINE 2
L3	LINE 3
LPS	LOW PRESSURE SWITCH
LUG	LUG GROUND
NTB	NEUTRAL TERMINAL BLOCK
O/L	OVER LOAD
OHT	OVER HEAT THERMOSTAT
PDS	PUMP DOWN SOLENOID
SSPS	SOLID STATE PROTECTIVE SYSTEM
SD	SMOKE DETECTOR
TRANS	TRANSFORMER
TSTAT	THERMOSTAT
UVM	UNDER VOLTAGE MONITOR
---	FIELD WIRING
+	DISCONNECT TAB - 1/4"
⊙	SPLICE-CLOSED END
□	TERMINAL BLOCK OR TERMINATION POINT

NOTES

- POWER SUPPLY, 380/415V-3PH-50HZ.
- ANY WIRE REPLACEMENT SHOULD BE OF 90°C OR ITS EQUIVALENT. USE COPPER CONDUCTOR WIRES ONLY.
- IF PDS & HEATERS ARE FACTORY INSTALLED, PLEASE READ BROKEN LINES AS CONTINUOUS LINES.
- POWER MUST BE SUPPLIED TO CRANKCASE HEATER FOR MINIMUM OF 12 HOURS PRIOR TO SYSTEM START UP. IF POWER IS OFF 6 HOURS OR MORE, CRANKCASE HEATER MUST BE ON FOR 12 HOURS BEFORE OPERATING THE SYSTEM.
- FAILURE TO FOLLOW THESE INSTRUCTIONS MAY RESULT IN COMPRESSOR DAMAGE.
- FUSED DISCONNECT SWITCH OR CIRCUIT BREAKER TO BE PROVIDED BY CONSUMER WITH RATING AS RECOMMENDED BY COOLINE.
- COMPRESSORS ARE PROVIDED WITH INTERNAL OVERLOAD.
- IF COMPRESSOR IS SUPPLIED WITH SSPS, CONNECT AS SHOWN. PLEASE ALLOW 2-3 MINUTES FOR SSPS SWITCH TO CLOSE, BEFORE STARTING THE UNIT.
- IF ANY CHANGE IN DIP SWITCH SETTING IS REQUIRED, TURN OFF POWER FIRST & SET REQUIRED SETTING.

PARTS LIST

MODEL NUMBER	PT036L	PT048L	PT060L	PT075L	PT090	PT100L	PT120L	PT180L	PT215L
COMPRESSOR	800-684-08	800-672-52	800-643-01	800-674-78	800-684-09	800-672-52	800-674-25	800-674-67/81	800-674-38
FAN MOTOR	800-555-26	800-555-26	800-555-26	800-555-26	800-545-68	800-545-68	800-545-68	800-545-68	800-545-68
FAN MOTOR CAPACITOR	800-353-15	800-353-15	800-353-15	800-353-15	N.A.	N.A.	N.A.	N.A.	N.A.
BLOWER MOTOR (STANDARD)	800-546-94	800-546-94	800-546-95	800-544-13	800-544-16	800-544-16	800-544-17	800-544-72	800-544-72
BLOWER WHEEL	800-707-10	800-707-10	800-707-10	800-707-46	800-707-02	800-707-02	800-707-02	800-707-02	800-707-23
CONDENSER FAN PROPELLER	800-225-02	800-225-02	800-225-02	800-225-02	800-224-23	800-224-23	800-224-23	800-224-23	800-224-23
COMPRESSOR CONTACTOR	800-095-01	800-095-01	800-095-01	800-095-01	800-095-01	800-095-01	800-095-01	800-095-01	800-736-22
BLOWER MOTOR CONTACTOR	800-736-27	800-736-27	800-736-27	800-095-01	800-095-01	800-095-01	800-095-01	800-098-55	800-098-55
AIRFLOW SWITCH	800-005-02	800-005-02	800-005-02	800-005-02	800-005-02	800-005-02	800-005-02	800-005-02	800-005-02
EXPANSION VALVE	800-195-16	800-195-20	800-195-22	800-181-00	800-183-01	800-181-00	800-181-00	800-182-00	800-182-00
DISTRIBUTOR	800-194-13	800-194-13	800-194-17	800-191-01	800-191-00	800-191-00	800-191-00	800-196-00	800-194-01
LOW PRESSURE SWITCH	800-557-00	800-557-00	800-557-00	800-557-00	800-557-00	800-557-00	800-557-00	800-557-00	800-557-00
HIGH PRESSURE SWITCH (OPTION)	800-558-00	800-558-00	800-558-00	800-558-00	800-558-00	800-558-00	800-558-00	800-558-00	800-558-00
FAN GRILLE	800-625-46	800-625-46	800-625-46	800-625-46	800-625-29	800-625-29	800-625-29	800-625-74	800-625-74
FILTER DRIER	800-531-08	800-531-08	800-531-08	800-531-08	800-531-08	800-531-08	800-531-08	800-531-05	800-531-05
SIGHT GLASS (OPTION)	800-201-00	800-201-00	800-201-00	800-201-00	800-201-00	800-201-00	800-200-00	800-200-00	800-200-00

MODEL NUMBER	PT240L	PT300L	PT360L
COMPRESSOR	800-674-19	800-674-12	800-674-72
FAN MOTOR	800-545-68	800-545-68	800-545-68
BLOWER MOTOR (STANDARD)	800-544-73	800-544-73	800-544-74
BLOWER WHEEL	800-707-23	800-707-23	800-707-23
CONDENSER FAN PROPELLER	800-224-23	800-225-02	800-225-02
COMPRESSOR CONTACTOR	800-736-22	800-736-22	800-736-22
BLOWER MOTOR CONTACTOR	800-098-55	800-098-55	800-098-57
AIRFLOW SWITCH	800-005-02	800-005-02	800-005-02
EXPANSION VALVE	800-185-00	800-186-00	800-186-00
DISTRIBUTOR	800-194-01	800-196-10	800-191-34
LOW PRESSURE SWITCH	800-557-00	800-557-00	800-557-00
HIGH PRESSURE SWITCH (OPTION)	800-558-00	800-558-00	800-558-00
FAN GRILLE	800-625-74	800-625-46	800-625-46
FILTER DRIER	800-531-05	800-531-05	800-531-01
SIGHT GLASS (OPTION)	800-200-00	800-200-00	800-200-01

OPTIONAL ITEMS:

ANTI ICE THERMOSTAT : 800-644-22 (COMMON TO ALL MODELS)

RETURN AIR FILTERS

Aluminum filter (1" Thick) : 800-254-10 (2 Each) for PT036 - PT060, 800-254-11 (2 Each) for PT075, 800-254-12 (2 Each) for PT090 - PT120, 800-254-13 (2 Each) for PT180, 800-254-14 (4 Each) for PT215 - PT240 & 800-254-15 (4 Each) for PT300 - PT360.

Aluminum filter (2" Thick) : 800-254-16 (2 Each) for PT036 - PT060, 800-254-17 (2 Each) for PT075, 800-254-18 (2 Each) for PT090 - PT120, 800-254-19 (2 Each) for PT180, 800-254-20 (4 Each) for PT215 - PT240 & 800-254-21 (4 Each) for PT300 - PT360.