

CHICAGO

Electric[®]Generators

GENERATOR

9 HP ROBIN[®] ELECTRIC START

Model 90300

OPERATING INSTRUCTIONS



Distributed Exclusively by



3491 Mission Oaks Blvd., Camarillo, CA 93011
Visit our Web site at: <http://www.harborfreight.com>

Copyright[®] 2003 by Harbor Freight Tools[®]. All rights reserved. No portion of this manual or any artwork contained herein may be reproduced in any shape or form without the express written consent of Harbor Freight Tools.

For technical questions, please call 1-800-444-3353.

PRODUCT SPECIFICATIONS

Item	Description
Electrical Requirements	4,500W Maximum Output; 4,000W Continuous Output 20 AMPs @ 120V / 20 AMPs @ 240V 60 Hz Output 120V Dual Outlet: 20 AMP, 3 Prong Grounded 120/240V Outlet: 20 AMP, 4 Prong Twistlock (L14-20) Overload Protection: Two 20 AMP Circuit Breakers Battery Type Required: 12V with at least 24Ah capacity (not included) Battery Size Capacity: 8" L x 5-1/4" W x 7-1/2 to 8" Tall
Engine Type	9 HP Robin®/Subaru® EX Series with Electric Start 4 Cycle / 265 CC Displacement Model #EX-27052020
Alternator	Two Pole / Single Phase / 60 Hz
Fuel Tank	6.5 Gallon
Estimated Run Time	14.5 Hours (w/ Full Tank @ 1/2 Load)
Overall Dimensions	29-3/4" x 25-1/2" x 20-5/8"
Weight	155 Pounds

⚠ WARNING THIS GENERATOR IS NOT INTENDED TO POWER SENSITIVE ELECTRONIC EQUIPMENT WITHOUT THE ADDITION OF AN APPROPRIATE LINE CONDITIONER (SOLD SEPARATELY).

This product requires oil and fuel to be added before starting. Attempting to start the engine without oil WILL ruin the engine and void the warranty.

Fill the engine with the following:

1.15 qt. of SAE 15W/40 oil

6.5 Gal. of unleaded gasoline with no oil added

Before starting the engine, refer to the engine owner's manual for additional engine maintenance information.

Call Harbor Freight Tools at 1-800-444-3353 for all technical questions and all inquiries regarding **GENERATOR AND ENGINE** replacement parts.

SAVE THIS MANUAL

You will need this manual for the safety warnings and precautions, operating, inspection, maintenance and cleaning procedures, parts list and assembly diagram. Keep your invoice with this manual. Write the invoice number on the inside of the front cover. Keep this manual and invoice in a safe and dry place for future reference.

UNPACKING

When unpacking, check to make sure all the parts shown on the Parts List on page 18 are included. If any parts are missing or broken, please call Harbor Freight Tools at the number shown on the cover of this manual as soon as possible.

REV 12/03; 02/04; 05/04; REV 03/06

GENERAL SAFETY RULES



READ AND UNDERSTAND ALL INSTRUCTIONS
Failure to follow all instructions listed below may result in
electric shock, fire, and/or serious injury.
SAVE THESE INSTRUCTIONS

WORK AREA

1. **Keep your work area clean and well lit.** Cluttered benches and dark areas invite accidents.
2. **Do not operate generators in explosive atmospheres, such as in the presence of flammable liquids, gases, or dust.** Generators create sparks which may ignite the dust or fumes.
3. **Keep bystanders, children, and visitors away while operating a generator.** Provide barriers or shields as needed.

ELECTRICAL SAFETY

4. **Grounded tools must be plugged into an outlet properly installed and grounded in accordance with all codes and ordinances. Never remove the grounding prong or modify the plug in any way. Do not use any adapter plugs. Check with a qualified electrician if you are in doubt as to whether the outlet is properly grounded.** If the tools should electrically malfunction or break down, grounding provides a low resistance path to carry electricity away from the user.
5. **Double insulated tools are equipped with a polarized plug (one blade is wider than the other). This plug will fit in a polarized outlet only one way. If the plug does not fit fully in the outlet, reverse the plug. If it still does not fit, contact a qualified electrician to install a polarized outlet. Do not change the plug in any way.** Double insulation eliminates the need for the three wire grounded power cord and grounded power supply system.
6. **Avoid body contact with grounded surfaces such as pipes, radiators, ranges, and refrigerators.** There is an increased risk of electric shock if your body is grounded.

7. **Do not expose generators to rain or wet conditions.** Water entering a generator will increase the risk of electric shock.
8. **Do not abuse Power Cords. Never use a Power Cord to carry any tool or pull the Plug from an outlet. Keep Power Cords away from heat, oil, sharp edges, or moving parts. Replace damaged Power Cords immediately.** Damaged Power Cords increase the risk of electric shock.
9. **When operating a power tool outside, use an outdoor extension cord marked “W-A” or “W”.** These extension cords are rated for outdoor use, and reduce the risk of electric shock.

PERSONAL SAFETY

10. **Stay alert. Watch what you are doing, and use common sense when operating a generator. Do not use a generator while tired or under the influence of drugs, alcohol, or medication.** A moment of inattention while operating generators may result in serious personal injury.
11. **Dress properly. Do not wear loose clothing or jewelry. Contain long hair. Keep your hair, clothing, and gloves away from moving parts.** Loose clothes, jewelry, or long hair can be caught in moving parts.
12. **Avoid accidental starting.** Be sure the ON/Off Switch is in its OFF position and the ignition key is removed from the Ignition Switch (45) when the generator is not in use.
13. **Remove adjusting keys or wrenches before turning the generator on.** A wrench or an adjusting key that is left attached to a rotating part of the generator may result in personal injury.
14. **Do not overreach. Keep proper footing and balance at all times.**
15. **Use safety equipment. Always wear eye protection.** Dust mask, nonskid safety shoes, hard hat, or hearing protection must be used for appropriate conditions.
16. **Never run the generator in an enclosed garage or any other type of enclosed structure without a proper, leak-free ventilation shaft.** Carbon Monoxide, an odorless, colorless deadly gas may accumulate and cause serious injury or death.

GENERATOR USE AND CARE

17. **Do not overload the generator. Use the correct generator for your application.** The correct generator will do the job better and safer at the rate for which it is designed.
18. **Do not use the generator if the Power Switch does not turn it on or off.** Any generator that cannot be controlled with the Power Switch is dangerous and must be properly repaired or replaced.

GENERATOR USE AND CARE (Continued)

19. **Disconnect the negative battery cable from the battery and remove the Ignition Key before making any adjustments, changing accessories, or storing the generator.** Such preventive safety measures reduce the risk of starting the generator accidentally.
20. **Store idle generators out of reach of children and other untrained persons.** Generators are dangerous in the hands of untrained users.
21. **Maintain generators with care.** Do not use a damaged generator. Tag damaged generators “Do not use” until repaired.
22. **Check for misalignment or binding of moving parts, breakage of parts, and any other condition that may affect the generator’s operation. If damaged, have the generator serviced before using.** Many accidents are caused by poorly maintained generators.
23. **Use only accessories that are recommended by the manufacturer for your model.** Accessories that may be suitable for one generator may become hazardous when used on another generator.

SERVICE

24. **Generator service must be performed only by qualified repair personnel.** Service or maintenance performed by unqualified personnel could result in a risk of injury.
25. **When servicing a generator, use only identical replacement parts. Follow instructions in the “*Inspection, Maintenance, And Cleaning*” section of this manual.** Use of unauthorized parts or failure to follow maintenance instructions may create a risk of electric shock or injury.

SPECIFIC PRODUCT WARNINGS AND PRECAUTIONS

1. **Do not use this product if under the influence of alcohol or drugs.** Read warning labels on prescriptions to determine if your judgement or reflexes are impaired while taking drugs. If there is any doubt, do not attempt to use this product.
2. **Use eye and hearing protection.** Wear ANSI approved safety impact eye goggles and hearing protection when using this product. ANSI approved safety impact eye goggles and hearing protectors are available from Harbor Freight Tools.
3. **Dress safely.** Do not wear loose clothing or jewelry, as they can become caught in moving parts. Wear a protective hair covering to prevent long hair from becoming caught in moving parts.
4. **Do not overreach.** Keep proper footing and balance at all times to prevent tripping, falling, back injury, etcetera.
5. **Industrial applications must follow OSHA requirements.**
6. **Stay alert.** Watch what you are doing at all times. Use common sense. Do not use this product when you are tired or distracted from the job at hand.
7. **Check for damaged parts.** Before using this product, carefully check that it will operate properly and perform its intended function. Check for damaged parts and any other conditions that may affect the operation of this product. Replace or repair damaged or worn parts immediately.
8. **Replacement parts and accessories:** When servicing, use only identical replacement parts. Only use accessories intended for use with this product. Approved accessories are available from Harbor Freight Tools.
9. **Maintain this product with care.** Keep this product clean and dry for better and safer performance. For your safety, service and maintenance should be performed regularly by a qualified technician.
10. **Use the right generator for the job.** Do not attempt to force a small generator to do the work of a larger industrial generator. There are certain applications for which this generator was designed. It will do the job better and more safely at the rate for which it was intended. Do not modify this generator, and do not use this generator for a purpose for which it was not intended.
11.  **WARNING!** The warnings, precautions, and instructions discussed in this

manual cannot cover all possible conditions and situations that may occur. The operator must understand that common sense and caution are factors which cannot be built into this product, but must be supplied by the operator.

Installation Precautions:

1.  **WARNING!** Before using the Generator, read and understand the *Engine manufacturer's Operation, Maintenance, and Parts manual*. Also, read the safety precautions in *this* manual. These should always be followed to reduce the risk of personal injury and damage to equipment.
2. Ensure installation meets all applicable safety, and local and national electrical codes. Have installation performed by a qualified, licensed electrician and building contractor.
3. All electrical work, including the earth-ground connection, should be completed by a licensed electrician.
4. Any separate fuel storage Generator supply facility must be built or installed in full compliance with all relevant local, state, and federal regulations.
5. If the generator is installed indoors, exhaust fumes must be piped out of the building using leak-free, heat-resistant piping. Pipes and silencer should not use any flammable materials, nor should they be installed near the same. Generator exhaust fumes must be within legal limits, including all local codes and ordinances.
6. The Generator is designed to be a portable unit. If however, the generator is to be permanently installed outdoors, it must be weatherproofed and should be soundproofed. Always follow local or state building codes. It should not be run outdoors without protection to the Generator and wiring conduit.
7. Never lift the Generator using the engine or alternator lifting lugs. Connect lifting equipment to the Frame of the Generator.
8. Before lifting the Generator, ensure the lift rigging and supporting structure are in good condition, and are rated to lift such a load.
9. Keep all personnel away from the suspended generator during relocating.
10. The supporting floor/ground surface should be level, and strong enough to safely hold the weight of the Generator. If the floor/ground surface is not level, strong cross members should be placed under the full length of the Generator Frame at its low side.

11. For trailer installation, the Generator should be mounted on the center point of the trailer, over the wheels.
12. Install sound- and weatherproofing only while it is not raining or snowing to avoid trapping moisture within the Generator's enclosure.

Fire And Explosion Precautions:

1. Gasoline fuel and fumes are flammable, and potentially explosive. Use proper fuel storage and handling procedures. Always have multiple ABC class fire extinguishers nearby.
2. Keep the Generator and surrounding area clean at all times.
3. When spills of fuel, oil occur, they must be cleaned up immediately. Dispose of fluids and cleaning materials as per any local, state, or federal codes and regulations. Store oil rags in a covered metal container.
4. Never store fuel or other flammable materials near the Generator.
5. Do not smoke, or allow sparks, flames or other sources of ignition around the Engine and Fuel Tank. Fuel vapors are explosive.
6. Keep grounded conductive objects, such as tools, away from exposed, live electrical parts and connections to avoid sparking or arcing. These events could ignite fumes or vapors.
7. Do not refill the Fuel Tank while the Engine is running or while the Engine is still hot. Do not operate the Generator with known leaks in the fuel system.
8. Excessive buildup of unburned fuel gases in the exhaust system can create a potentially explosive condition. This buildup can occur after repeated failed start attempts, valve testing, or hot engine shutdown. If this occurs, open exhaust system drain plugs, if equipped, and allow the gases to dissipate before attempting to restart the Generator.
9. Use only engine manufacturer recommended fuel and oil.

Mechanical Precautions:

1. **ALWAYS** turn off the Engine. Allow the Engine to completely cool, disconnect the negative battery cable from the battery, and remove the key from the Ignition Switch (45) before carrying out maintenance.

2. Check for damaged parts. Before using the Generator, any part that appears damaged should be carefully checked to determine that it will operate properly and perform its intended function. Check for alignment and binding of moving parts, any broken parts or mounting fixtures, and any other condition that may affect proper operation. Any part that is damaged should be properly repaired or replaced by a qualified technician.
3. The Generator is designed with guards for protection from moving parts. In any case, care must still be taken to protect personnel and equipment from other mechanical hazards when working around the generator.
4. Do not operate the Generator with safety guards removed. While the Generator is running, do not attempt to reach around the safety guards for maintenance or any other reason.
5. Keep hands, arms, long hair, loose clothing, and jewelry away from moving parts. Be aware that when Engine parts are moving fast they cannot be seen clearly.
6. Keep access doors on enclosures closed and locked when access is not required.
7. When working on or around the Generator always wear protective clothing including ANSI approved safety gloves, safety eye goggles, and safety hat.
8. Do not alter or adjust any part of the Generator that is assembled and supplied by the manufacturer.
9. Always follow and complete scheduled Engine and Generator maintenance.

Chemical Precautions:

1. Avoid contact with hot fuel, oil, exhaust fumes, and solid surfaces.
2. Avoid body contact with fuels, oils, and lubricants used in the Generator. If swallowed, seek medical treatment immediately. Do not induce vomiting if fuel is swallowed. For skin contact, immediately wash with soap and water. For eye contact, immediately flush eyes with clean water.

Noise Precautions:

1. Prolonged exposure to noise levels above 85 dBA is hazardous to hearing. Always wear ANSI approved ear protection when operating or working around the Generator when it is running.

Electrical Precautions:

1. All connections and conduits from the Generator to the load must only be installed by trained and licensed electricians, and in compliance with all relevant local, state, and federal electrical codes and standards, and other regulations where applicable.
2. The Generator must be properly earth-grounded by a licensed electrician in accordance with all relevant electrical codes and standards before operation.
3. If an extension cord (not included) is used, make sure to use only UL® approved cords having the correct gauge and length. **(See Figure A.)**

FIGURE A

REQUIRED MINIMUM EXTENSION CORD GAUGE – 120/ 240 VOLT					
NAMEPLATE AMPERES (At Full Load)	EXTENSION CORD LENGTH				
	0 - 25 Feet	25 - 50 Feet	50 -100 Feet	100 – 150 Feet	150– 200 Feet
0 - 5	16	16	16	12	12
5.1 - 8	16	16	14	10	-
8.1 - 12	14	14	12	-	-
12.1 - 15	12	12	10	-	-
15.1 - 20	10	10	10	-	-

4. Do not attempt to connect or disconnect load connections while standing in water, or on wet or soggy ground.
5. Do not touch electrically energized parts of the Generator and interconnecting cables or conductors with any part of the body, or with any non-insulated conductive object.
6. Connect the generator only to a load or electrical system (120 volt and 240 volt) that is compatible with the electrical characteristics and rated capacities of the Generator.
7. Before servicing equipment powered by the Generator, disconnect the equipment from its power input.
8. Keep all electrical equipment clean and dry. Replace any wiring where the insulation is cracked, cut, abraded or otherwise degraded. Replace terminals that are worn, discolored, or corroded. Keep terminals clean and tight.
9. Insulate all connections and disconnected wires.
10. Guard against electric shock. Prevent body contact with grounded surfaces such as pipes, radiators, ranges, and refrigerator enclosures.

11. Use only Class BC or Class ABC fire extinguishers on electrical fires.
12.  **WARNING!** People with pacemakers should consult their physician(s) before using this product. Operation of electrical equipment in close proximity to a heart pacemaker could cause interference or failure of the pacemaker.

INSTALLATION

1. **NOTE:** Prior to powering tools and equipment, make sure the Generator's rated voltage, wattage, and amperage capacity (120V/ 20 AMPs and 240V/ 20 AMPs) is adequate to supply all electrical loads that the unit will power. If powering exceeds the Generator's capacity, it may be necessary to group one or more of the tools and/or equipment for connection to a separate Generator.
2. Electrical and other permits may be required for the installation of emergency power systems. Investigate the local building and electrical codes before installing this unit. Installation must be completed by licensed contractors.
3.  **WARNING!** The Generator weighs 155 pounds. Use care and the proper lifting or hoisting equipment when moving it to the installation location. Always connect hoist lines to the Frame (21) of the Generator.

GENERAL LOCATION

1. It is recommended to locate and install the Generator in a protected outdoor area where cooling air is readily available (**see previous warning section**).
2. Install the Generator so that the air inlets and outlets are not blocked by obstructions such as bushes, trees, or snow drifts. Locating it in the path of heavy winds or snowdrifts may require the placement of a barrier for protection. The air inlet, in normal weather conditions, should face the prevailing wind direction.
3. Install the Generator on a concrete slab or other area where rain drainage or flood waters can not reach it.
4. Generator placement should allow four feet of access to all sides for maintenance.
5. Place the Generator as close as possible to the electrical tools and equipment being powered to reduce the length of extension cords.
6. If the Generator is located indoors, or in a Generator house, the Engine exhaust must be ventilated to the outdoors using professionally installed, leakproof, heat resistant, flexible, metal tubing.

GENERATOR SUPPORT AND MOUNTING

1. Mount the Generator on a concrete slab capable of supporting the weight of the Generator. The slab must extend on all sides beyond the Frame (21) by at least one foot. Contact a cement contractor for slab specifications if necessary. Attach the Frame to the concrete slab using 3/8" diameter masonry type anchor bolts (not supplied).

GROUNDING THE GENERATOR

1. **NOTE:** It is recommended that only a trained and licensed electrician perform this procedure. (Generators without a permanent installation may not need to be grounded, check local codes and ordinances.)
2. Connect a #6 AWG grounding wire (not included) from the Grounding Point on the front panel to a grounding rod (not included) that has been driven at least 24 inches deep into the earth. The grounding rod must be an earth-driven copper or brass rod (electrode) which can adequately ground the Generator.
(See Figure H, page 15.)

Note: Local codes and ordinances may vary. Always check local codes and install in accord with all laws.

REV 08/04; 11/04

OPERATING INSTRUCTIONS

NOTE: For additional references to the parts listed in the following pages, refer to the **Assembly Diagram on page 19.**

To Install A Battery:

1. **NOTE:** The Generator requires the installation of a **12 volt** battery (not included). **The battery must be no larger than 5" wide x 7-3/4" long x 8-1/2" high.**
2. **⚠ WARNING!** Battery fluid leakage may occur under extreme usage or temperature conditions. If battery fluid comes in contact with skin, wash with soap and water and rinse with lemon juice and vinegar. If the fluid comes into contact with the eyes, flush with water for several minutes and contact a doctor immediately. Never burn a battery, as it can explode in a fire. Do not use the Generator with a leaking battery. Contact local solid waste authorities for instructions on correct disposal or recycling of a battery.
3. Carefully place a fully charged, 12 volt battery in the Battery Holder located at the base of the Generator.
4. The Engine has *two* power cables that must be connected to the battery. Connect the cable with the **RED (+ POSITIVE)** terminal to the **(+ POSITIVE)** terminal on the battery. Connect the cable with the **BLACK (- NEGATIVE)** terminal to the **(- NEGATIVE)** terminal on the battery. **(See Figure C.)**
5. Insert the bottom, "L" shaped portion of one Battery Support Stud (39) in each end of the Battery Holder. Then, insert the Battery Holding Plate (40) onto the two Battery Support Studs and allow the Battery Holding Plate to rest on top of the battery. Secure the battery in place by tightening the two Nuts (49) onto the two Battery Support Studs. Do not overtighten, as it may damage the battery. **(See Figure C.)**

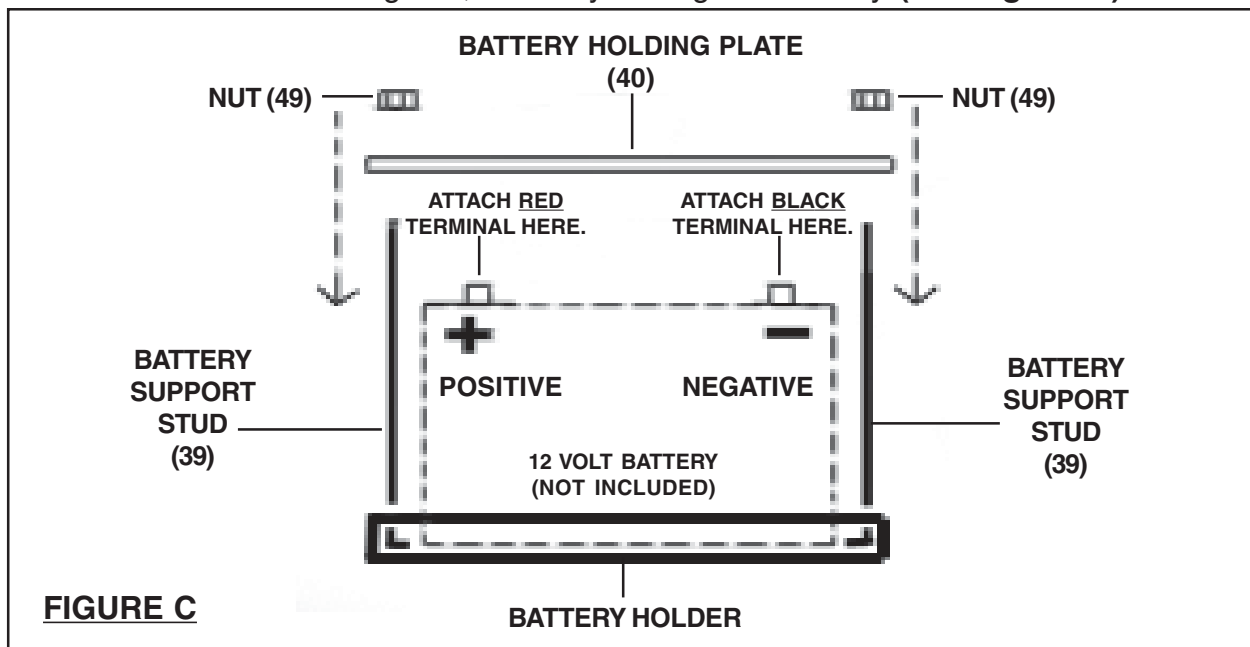

Pre-Start Checks:

1. **NOTE:** During operation, it may be necessary to refer to the *Engine manufacturer's Operation, Maintenance, and Parts manual* (included) for detailed information about starting, running, and stopping the Engine.
2. Check to make sure the Engine's "ON/OFF" Switch is in its "OFF" position.
3. Unscrew and remove the Engine's Oil Fill Cap located at the bottom of the Engine Crankcase. Check to make sure the oil level is even with the top of the Oil Fill Hole. If necessary, add oil until its level is even with the Oil Fill Hole. Then, screw the Oil Fill Cap back into the Oil Fill Hole. **NOTE:** Check with the Engine manufacturer's manual for the proper type of engine oil required for use.
(See Figure D.)
4. Check the Fuel Gauge (34) for the amount of unleaded gasoline in the Fuel Tank (32). If necessary, remove the Fuel Tank Cap (37) and refill the Fuel Tank with unleaded gasoline. Then, replace the Fuel Tank Cap.
(See Figure E.)

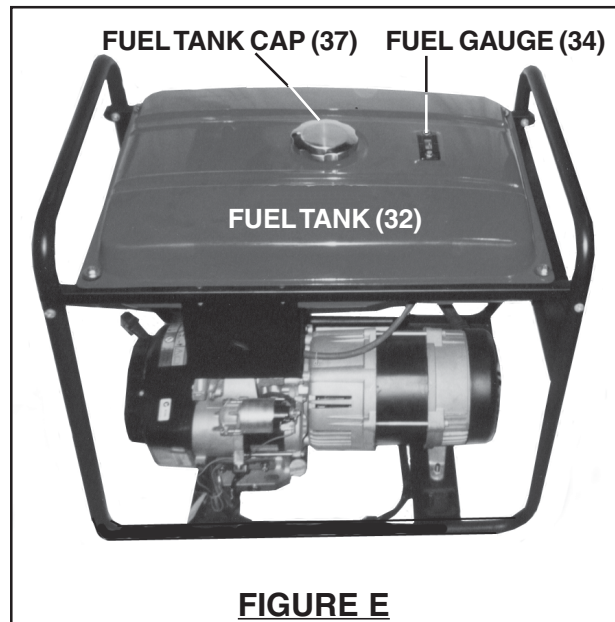
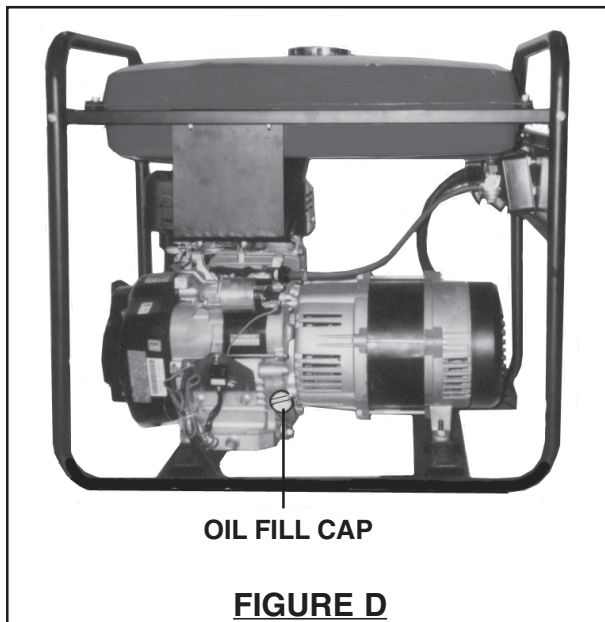

To Start The Generator:

1. Turn the Fuel Valve (31) to its vertical "OPEN" position. (See Figure F.)
2. Move the Engine's Choke all the way to the left to its "START" position. (See Figure F.)
3. Turn the Engine's "ON/OFF" switch to its "ON" position. (See Figure G.)
4. Insert the Ignition Key into the Ignition Switch (45), and turn the Ignition Key to the right to start the Engine. (See Figure H.)
5. Allow the Engine to run for several seconds, then move the Engine's Choke all the way to the left to its "RUN" position. (See Figure F.)

NOTE: DO NOT ATTEMPT TO ADJUST THE ENGINE'S THROTTLE! This engine uses a governor device to automatically control the engine's speed. If the throttle is adjusted, it may result in decreased efficiency and/or damage to the unit.

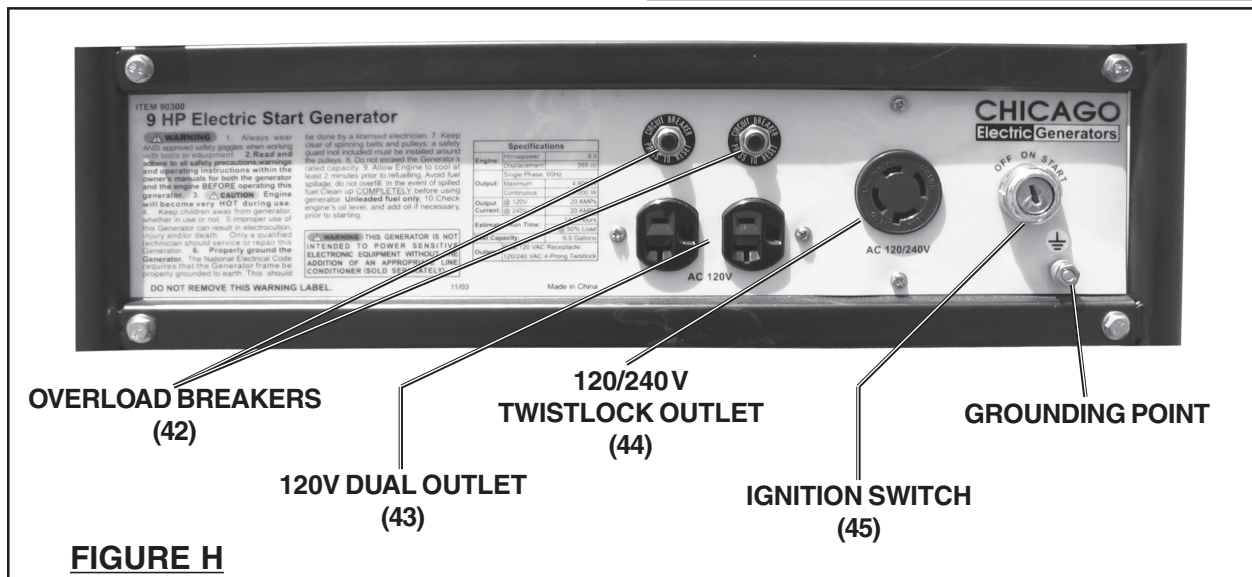
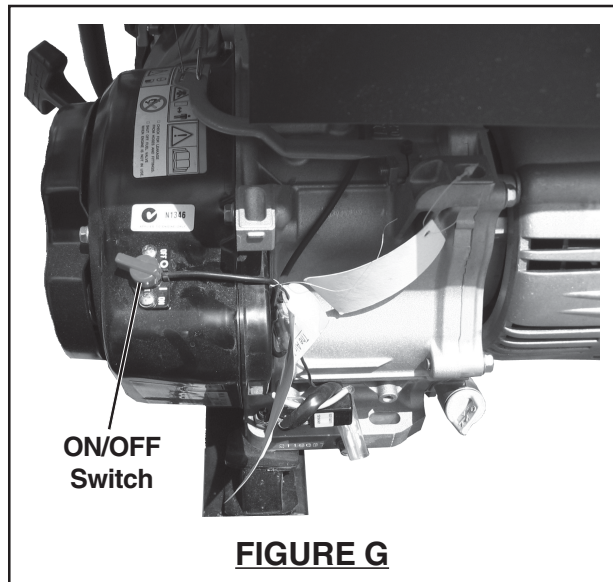
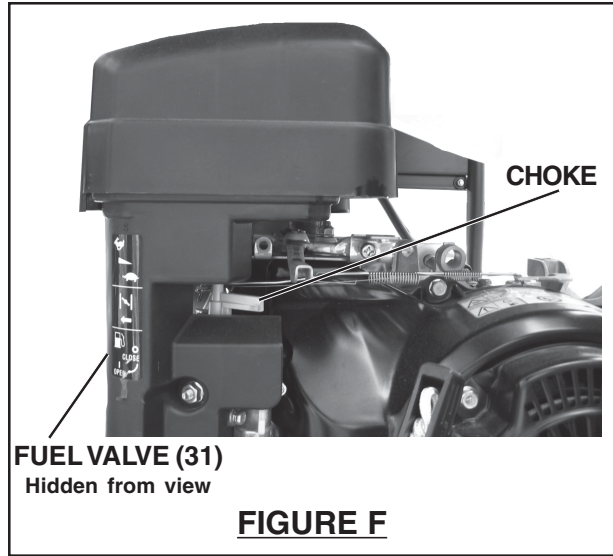

Powering Tools And Equipment:

1. Prior to powering tools and equipment, make sure the Generator's rated voltage, wattage, and amperage capacity (120V/ 20 AMP and 240V/ 20 AMP) is adequate to supply all electrical loads that the unit will power. If powering exceeds the Generator's capacity, it may be necessary to group one or more of the tools and/or equipment for connection to a separate Generator.
2. Once the Generator is running, simply connect the Power Cords of 120 volt powered tools and equipment into the 120 volt Outlets (43). If a 240 volt tool or equipment is used, connect its power cord into the 240 volt Twistlock Outlet (44). **(See Figure I.)**
3. **NOTE:** The Generator features *two* AC Non-Fuse Overload Breakers (42) to protect the AC circuit in case of an overload. Should an overload occur one or both of the Breakers will "trip", interrupting the circuit (disconnecting power to the connected tools and/or equipment). In this case, refer to Step #1 in this section. Then, reset the circuitry system by depressing the Breaker(s). Restart the Generator and continue powering the remaining tools and equipment. **(See Figure I.)**

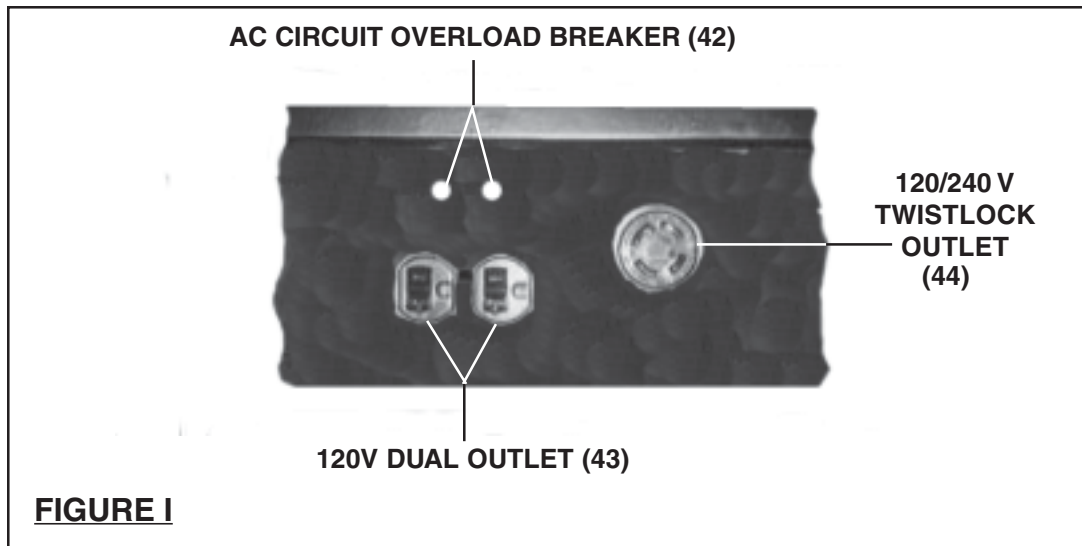

4. When finished using the Generator, turn the ON/OFF switch on the engine's fan shroud to its "**OFF**" position, and remove the Ignition Key from the Ignition Switch (45). **(See Figure H.)**
5. After the Engine and Generator have completely cooled, store the Generator in a safe, clean, dry location (if not already installed in one).

INSPECTION, MAINTENANCE, AND CLEANING

1. **NOTE:** Preventative maintenance procedures and frequency will vary depending on the amount of Generator use. Refer to the *Engine manufacturer's Operation, Maintenance, and Parts manual* (included) for detailed information regarding maintenance of the Engine.
2. **CAUTION!** Always turn off the Engine and remove the Ignition Key. Allow sufficient time for the Engine and Generator to completely cool. Then, disconnect the negative battery cable from the battery before performing any inspection, maintenance, or cleaning.
3. **BEFORE EACH USE,** inspect the general condition of the Generator. Check for loose screws, misalignment or binding of moving parts, cracked or broken parts, damaged electrical wiring, and any other condition that may affect its safe operation. If abnormal noise or vibration occurs, have the problem corrected before further use. **Do not use damaged equipment.**
4. **BEFORE EACH USE,** check to make sure the Engine's oil level is adequate. Refer to the Engine manufacturer's Operation, Maintenance, and Parts Manual (included) for specific information.
5. **DAILY:** With a soft brush, cloth, or vacuum, remove all debris from the Generator. Then, use a premium quality, lightweight machine oil to lubricate all moving parts.

PLEASE READ THE FOLLOWING CAREFULLY

THE MANUFACTURER AND/OR DISTRIBUTOR HAS PROVIDED THE PARTS LIST AND ASSEMBLY DIAGRAM IN THIS MANUAL AS A REFERENCE TOOL ONLY. NEITHER THE MANUFACTURER OR DISTRIBUTOR MAKES ANY REPRESENTATION OR WARRANTY OF ANY KIND TO THE BUYER THAT HE OR SHE IS QUALIFIED TO MAKE ANY REPAIRS TO THE PRODUCT, OR THAT HE OR SHE IS QUALIFIED TO REPLACE ANY PARTS OF THE PRODUCT. IN FACT, THE MANUFACTURER AND/OR DISTRIBUTOR EXPRESSLY STATES THAT ALL REPAIRS AND PARTS REPLACEMENTS SHOULD BE UNDERTAKEN BY CERTIFIED AND LICENSED TECHNICIANS, AND NOT BY THE BUYER. THE BUYER ASSUMES ALL RISK AND LIABILITY ARISING OUT OF HIS OR HER REPAIRS TO THE ORIGINAL PRODUCT OR REPLACEMENT PARTS THERETO, OR ARISING OUT OF HIS OR HER INSTALLATION OF REPLACEMENT PARTS THERETO.

PARTS LIST

Part No.	Description	Qty.	Part No.	Description	Qty.
1	Bolt M5*12	2	26	Rail	2
2	Connection board	1	27	Lock washer M6	4
3	Bolt M5*20	4	28	Bolt M8-55	4
4	Bolt M5*12	2	29	Lock washer M8	4
5	Cable sheath	1	30	Rail protection	4
6	Rear cover	1	31	Fuel valve	1
7	Bolt M6*16	2	32	Fuel tank	1
8	Bolt M6*125	4	33	Bolt M6-25	4
9	Capacitor	1	34	Fuel gauge	1
10	Alternator back cover	1	35	Bolt M5-12	2
11	Bolt 5/16" x 175	1	36	Filter	1
12	Stator	1	37	Fuel tank cap	1
13	Bridge combination	2	38	Seal ring	1
14	Voltage dependent resistor	2	39	Battery support stud	2
15	Rotor	1	40	Battery holding plate	1
16	Hex bolt 3/8" x 30	4	41	Switch box cover	1
17	Fan	1	42	Overload breaker	2
18	Alternator front cover	1	43	Outlet (20A/120V)	1
19	Bolt M8-12	4	44	Twist lock outlet (20A/120V/240V)	1
20	Panel	1	45	Ignition switch	1
21	Frame	1	46	Lock washer M5	4
22	Shock absorber support	4	47	Heat insulation board	1
23	Bolt M12-30	4	48	Bolt M5-35	4
24	Lock washer M10	4	49	Nut	2
25	Shock absorber	4			

WIRING DIAGRAM

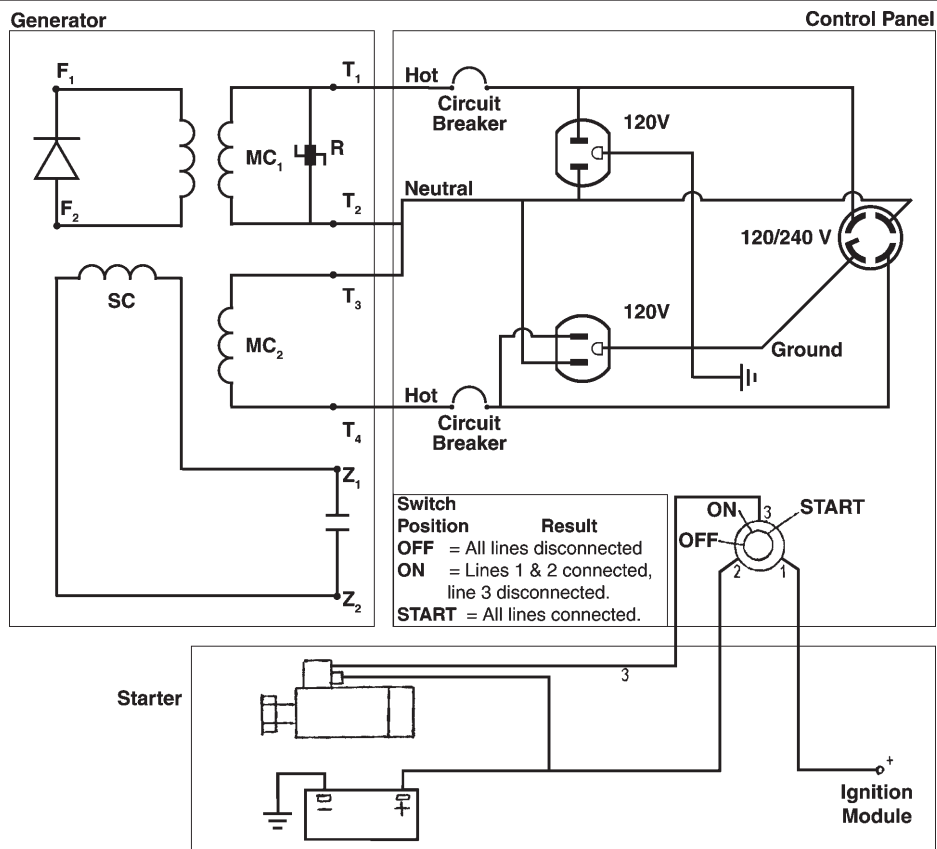

REV 06/04; 12/04; 01/05; REV 03/06

ASSEMBLY DIAGRAM

NOTE: Some parts are listed and shown for illustration purposes only, and are not available individually as replacement parts.

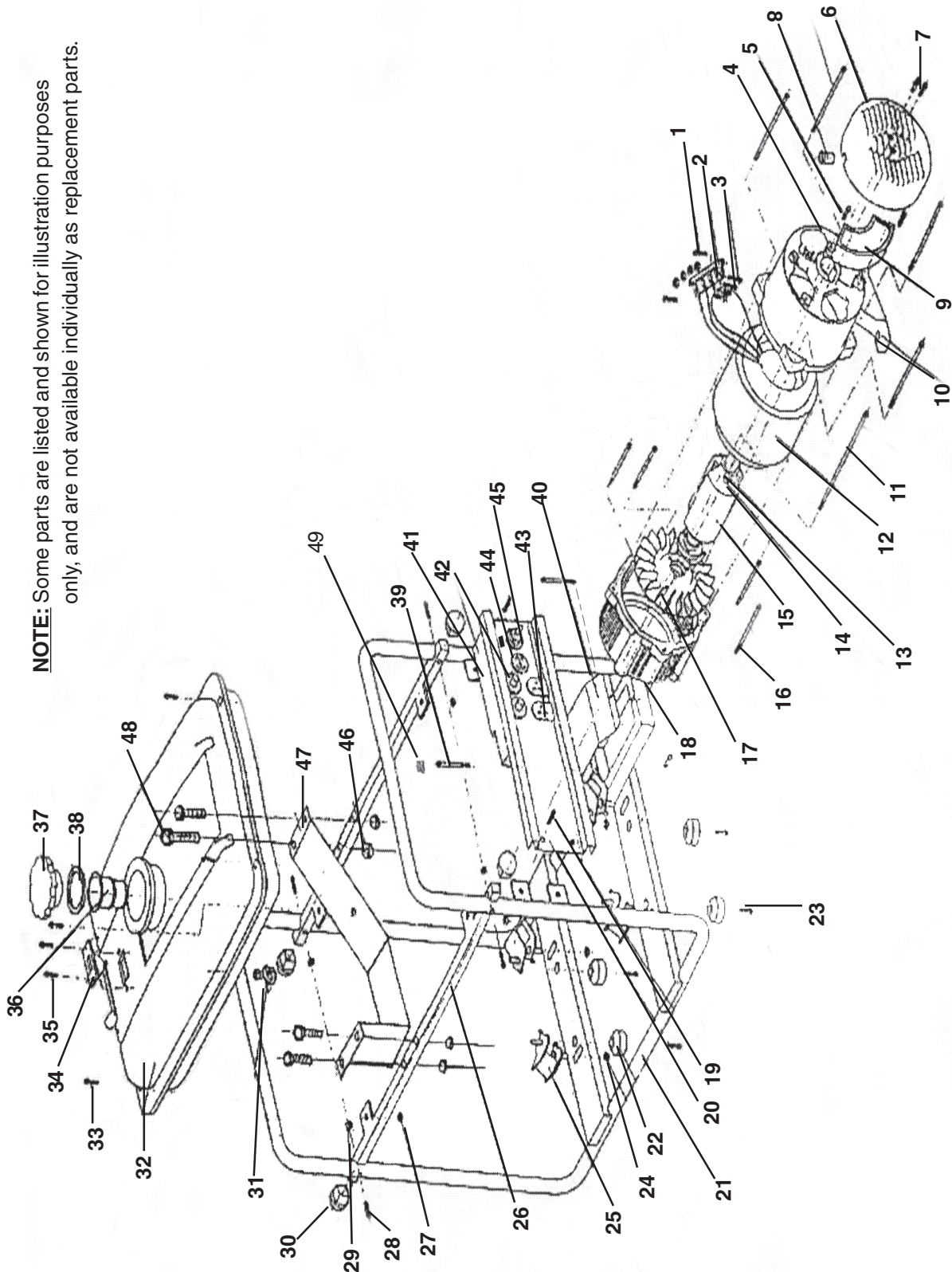

REV 06/04

REV 12/04

SKU 90300

For technical questions, please call 1-800-444-3353.

PAGE 19

WARRANTY CARD

CHICAGO 1 YEAR **Electric Generators** WARRANTY

Harbor Freight Tools Co. makes every effort to assure that its products meet high quality and durability standards, and warrants to the original purchaser that this product is free from defects in materials and workmanship for the period of one year from the date of purchase (90 days if used by a professional contractor or if used as rental equipment). See engine manufacturer's warranty which covers engine. This warranty does not apply to damage due directly or indirectly, to misuse, abuse, negligence or accidents, repairs or alterations outside our facilities, or to lack of maintenance. We shall in no event be liable for death, injuries to persons or property, or for incidental, contingent, special or consequential damages arising from the use of our product. Some states do not allow the exclusion or limitation of incidental or consequential damages, so the above limitation of exclusion may not apply to you. THIS WARRANTY IS EXPRESSLY IN LIEU OF ALL OTHER WARRANTIES, EXPRESS OR IMPLIED, INCLUDING THE WARRANTIES OF MERCHANTABILITY AND FITNESS.

To take advantage of this warranty, the product or part must be returned to us with transportation charges prepaid. Proof of purchase date and an explanation of the complaint must accompany the merchandise. If our inspection verifies the defect, we will either repair or replace the product at our election or we may elect to refund the purchase price if we cannot readily and quickly provide you with a replacement. We will return repaired products at our expense, but if we determine there is no defect, or that the defect resulted from causes not within the scope of our warranty, then you must bear the cost of returning the product.

This warranty gives you specific legal rights and you may also have other rights which vary from state to state.

3491 Mission Oaks Blvd. • PO Box 6009 • Camarillo, CA 93011 • (800) 444-3353