

# Owner's Manual & Safety Instructions

**Save This Manual** Keep this manual for the safety warnings and precautions, assembly, operating, inspection, maintenance and cleaning procedures. Write the product's serial number in the back of the manual near the assembly diagram (or month and year of purchase if product has no number). Keep this manual and the receipt in a safe and dry place for future reference.

**ITEM 68987**

**CHICAGO  ELECTRIC  
POWER TOOLS**

## 4" BISCUIT PLATE JOINER



Visit our website at: <http://www.harborfreight.com>  
Email our technical support at: [tech@harborfreight.com](mailto:tech@harborfreight.com)

When unpacking, make sure that the product is intact and undamaged. If any parts are missing or broken, please call 1-800-444-3353 as soon as possible.

Copyright© 2011 by Harbor Freight Tools®. All rights reserved.  
No portion of this manual or any artwork contained herein may be reproduced in any shape or form without the express written consent of Harbor Freight Tools. Diagrams within this manual may not be drawn proportionally. Due to continuing improvements, actual product may differ slightly from the product described herein. Tools required for assembly and service may not be included.

### **⚠ WARNING**

**Read this material before using this product.  
Failure to do so can result in serious injury.  
SAVE THIS MANUAL.**

# Table of Contents

Safety .....	2	Maintenance .....	14
Specifications .....	8	Parts List and Diagram .....	16
Setup .....	8	Warranty .....	19
Operation.....	9		



## WARNING SYMBOLS AND DEFINITIONS

	This is the safety alert symbol. It is used to alert you to potential personal injury hazards. Obey all safety messages that follow this symbol to avoid possible injury or death.
	Indicates a hazardous situation which, if not avoided, will result in death or serious injury.
	Indicates a hazardous situation which, if not avoided, could result in death or serious injury.
	Indicates a hazardous situation which, if not avoided, could result in minor or moderate injury.
	Addresses practices not related to personal injury.

## IMPORTANT SAFETY INFORMATION

### General Power Tool Safety Warnings

#### WARNING

**Read all safety warnings and instructions.**

*Failure to follow the warnings and instructions may result in electric shock, fire and/or serious injury.*

**Save all warnings and instructions for future reference.**

*The term "power tool" in the warnings refers to your mains-operated (corded) power tool or battery-operated (cordless) power tool.*

### Work area safety

- Keep work area clean and well lit.**  
*Cluttered or dark areas invite accidents.*
- Do not operate power tools in explosive atmospheres, such as in the presence of flammable liquids, gases or dust.** *Power tools create sparks which may ignite the dust or fumes.*
- Keep children and bystanders away while operating a power tool.**  
*Distractions can cause you to lose control.*

## Electrical safety

---

1. **Power tool plugs must match the outlet. Never modify the plug in any way. Do not use any adapter plugs with grounded power tools.** *Unmodified plugs and matching outlets will reduce risk of electric shock.*
2. **Avoid body contact with grounded surfaces such as pipes, radiators, ranges and refrigerators.** *There is an increased risk of electric shock if your body is grounded.*
3. **Do not expose power tools to rain or wet conditions.** *Water entering a power tool will increase the risk of electric shock.*
4. **Do not abuse the cord. Never use the cord for carrying, pulling or unplugging the power tool. Keep cord away from heat, oil, sharp edges or moving parts.** *Damaged or entangled cords increase the risk of electric shock.*
5. **When operating a power tool outdoors, use an extension cord suitable for outdoor use.** *Use of a cord suitable for outdoor use reduces the risk of electric shock.*
6. **If operating a power tool in a damp location is unavoidable, use a Ground Fault Circuit Interrupter (GFCI) protected supply.** *Use of a GFCI reduces the risk of electric shock.*

## Personal safety

---

1. **Stay alert, watch what you are doing and use common sense when operating a power tool. Do not use a power tool while you are tired or under the influence of drugs, alcohol or medication.** *A moment of inattention while operating power tools may result in serious personal injury.*
2. **Use safety equipment. Always wear eye protection.** *Safety equipment such as dust mask, non-skid safety shoes, hard hat, or hearing protection used for appropriate conditions will reduce personal injuries.*
3. **Prevent unintentional starting. Ensure the switch is in the off-position before connecting to power source and/or battery pack, picking up or carrying the tool.** *Carrying power tools with your finger on the switch or energizing power tools that have the switch on invites accidents.*
4. **Remove any adjusting key or wrench before turning the power tool on.** *A wrench or a key left attached to a rotating part of the power tool may result in personal injury.*
5. **Do not overreach. Keep proper footing and balance at all times.** *This enables better control of the power tool in unexpected situations.*
6. **Dress properly. Do not wear loose clothing or jewelry. Keep your hair, clothing and gloves away from moving parts.** *Loose clothes, jewelry or long hair can be caught in moving parts.*
7. **If devices are provided for the connection of dust extraction and collection facilities, ensure these are connected and properly used.** *Use of these devices can reduce dust-related hazards.*
8. **Only use safety equipment that has been approved by an appropriate standards agency.** *Unapproved safety equipment may not provide adequate protection. Eye protection must be ANSI-approved and breathing protection must be NIOSH-approved for the specific hazards in the work area.*

## Power tool use and care

- 1. Do not force the power tool. Use the correct power tool for your application.**  
*The correct power tool will do the job better and safer at the rate for which it was designed.*
- 2. Do not use the power tool if the switch does not turn it on and off.** *Any power tool that cannot be controlled with the switch is dangerous and must be repaired.*
- 3. Disconnect the plug from the power source and/or the battery pack from the power tool before making any adjustments, changing accessories, or storing power tools.**  
*Such preventive safety measures reduce the risk of starting the power tool accidentally.*
- 4. Store idle power tools out of the reach of children and do not allow persons unfamiliar with the power tool or these instructions to operate the power tool.** *Power tools are dangerous in the hands of untrained users.*
- 5. Maintain power tools. Check for misalignment or binding of moving parts, breakage of parts and any other condition that may affect the power tool's operation. If damaged, have the power tool repaired before use.** *Many accidents are caused by poorly maintained power tools.*
- 6. Keep cutting tools sharp and clean.** *Properly maintained cutting tools with sharp cutting edges are less likely to bind and are easier to control.*
- 7. Use the power tool, accessories and blades etc. in accordance with these instructions, taking into account the working conditions and the work to be performed.** *Use of the power tool for operations different from those intended could result in a hazardous situation.*

## Service

Have your power tool serviced by a qualified repair person using only identical replacement parts. *This will ensure that the safety of the power tool is maintained.*

## Biscuit Plate Joiner Safety Warnings

- 1. ⚠DANGER: Keep hands away from cutting area and the blade. Keep your second hand on auxiliary handle, or motor housing.** *If both hands are holding the saw, they cannot be cut by the blade.*
- 2. Disc cutters must be rated for at least the speed recommended on the tool.** *Disc cutters running over rated speed can fly apart and cause injury.*
- 3. Always use the guard.** *The guard protects the operator from broken disc cutter fragments and unintentional contact with the disc cutter.*
- 4. Maintain labels and nameplates on the tool.** *These carry important safety information. If unreadable or missing, contact Harbor Freight Tools for a replacement.*
- 5. Avoid unintentional starting.** *Prepare to begin work before turning on the tool.*
- 6. Do not lay the tool down until it has come to a complete stop.** *Moving parts can grab the surface and pull the tool out of your control.*
- 7. When using a handheld power tool, maintain a firm grip on the tool with both hands to resist starting torque.**
- 8. Do not depress the spindle lock when starting or during operation.**
- 9. Do not leave the tool unattended when it is plugged into an electrical outlet.** *Turn off the tool, and unplug it from its electrical outlet before leaving.*
- 10. This product is not a toy.** *Keep it out of reach of children.*
- 11. Never hold piece being cut in your hands or across your leg. Secure the workpiece to a stable platform.** *It is important to support the work properly to minimize body exposure, blade binding, or loss of control.*
- 12. Always use blades with correct size and shape (diamond versus round) of arbor holes.** *Blades that do not match the mounting hardware of the saw will run eccentrically, causing loss of control.*

# Biscuit Plate Joiner Biscuit Plate Joiner Safety Warnings (cont.)

13. **Never use damaged or incorrect blade washers or bolt.** *The blade washers and bolt were specially designed for your saw, for optimum performance and safety of operation.*
14. **Do not use dull or damaged blades.**
15. **Blades must be rated to at least the maximum speed marked on the tool.**
16. **Maintain labels and nameplates on the tool.** These carry important safety information. If unreadable or missing, contact Harbor Freight Tools for a replacement.
17. **Do not leave the tool unattended when it is plugged into an electrical outlet.** Turn off the tool, and unplug it from its electrical outlet before leaving.
18. **Use clamps (not included) or other practical ways to secure and support the workpiece to a stable platform.** Holding the work by hand or against your body is unstable and may lead to loss of control.
19. **People with pacemakers should consult their physician(s) before use.** Electromagnetic fields in close proximity to heart pacemaker could cause pacemaker interference or pacemaker failure. In addition, people with pacemakers should:
  - Avoid operating alone.
  - Do not use with power switch locked on.
  - Properly maintain and inspect to avoid electrical shock.
  - Any power cord must be properly grounded. Ground Fault Circuit Interrupter (GFCI) should also be implemented – it prevents sustained electrical shock.
20. **WARNING: Some dust created by power sanding, sawing, grinding, drilling, and other construction activities, contains chemicals known [to the State of California] to cause cancer, birth defects or other reproductive harm.** Some examples of these chemicals are:
  - Lead from lead-based paints
  - Crystalline silica from bricks and cement or other masonry products
  - Arsenic and chromium from chemically treated lumberYour risk from these exposures varies, depending on how often you do this type of work. To reduce your exposure to these chemicals: work in a well ventilated area, and work with approved safety equipment, such as those dust masks that are specially designed to filter out microscopic particles. (California Health & Safety Code § 25249.5, *et seq.*)
21. **WARNING: Handling the cord on this product will expose you to lead, a chemical known to the State of California to cause cancer, and birth defects or other reproductive harm. Wash hands after handling.** (California Health & Safety Code § 25249.5, *et seq.*)
22. **The warnings, precautions, and instructions discussed in this instruction manual cannot cover all possible conditions and situations that may occur.** It must be understood by the operator that common sense and caution are factors which cannot be built into this product, but must be supplied by the operator.

## Vibration Safety

This tool vibrates during use. Repeated or long-term exposure to vibration may cause temporary or permanent physical injury, particularly to the hands, arms and shoulders. To reduce the risk of vibration-related injury:

1. **Anyone using vibrating tools regularly or for an extended period should first be examined by a doctor and then have regular medical check-ups to ensure medical problems are not being caused or worsened from use.** Pregnant women or people who have impaired blood circulation to the hand, past hand injuries, nervous system disorders, diabetes, or Raynaud's Disease should not use this tool. If you feel any medical or physical symptoms related to vibration (such as tingling, numbness, and white or blue fingers), seek medical advice as soon as possible.
2. **Do not smoke during use.** Nicotine reduces the blood supply to the hands and fingers, increasing the risk of vibration-related injury.
3. **Wear suitable gloves to reduce the vibration effects on the user.**
4. **Use tools with the lowest vibration when there is a choice.**
5. **Include vibration-free periods each day of work.**
6. **Grip tool as lightly as possible (while still keeping safe control of it).** Let the tool do the work.
7. **To reduce vibration, maintain the tool as explained in this manual.** If any abnormal vibration occurs, stop use immediately.



**SAVE THESE INSTRUCTIONS.**

# Biscuit Plate Joiner Safety Warnings (cont.)

## Grounding

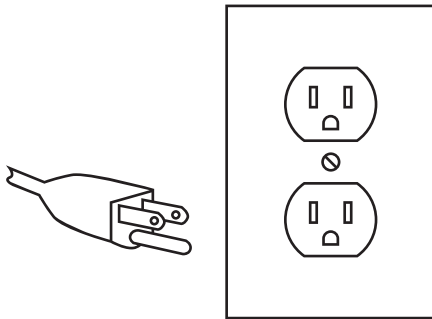
### ⚠ WARNING



**TO PREVENT ELECTRIC SHOCK AND DEATH FROM INCORRECT GROUNDING WIRE CONNECTION:**

Check with a qualified electrician if you are in doubt as to whether the outlet is properly grounded. Do not modify the power cord plug provided with the tool. Never remove the grounding prong from the plug. Do not use the tool if the power cord or plug is damaged. If damaged, have it repaired by a service facility before use. If the plug will not fit the outlet, have a proper outlet installed by a qualified electrician.

## Grounded Tools: Tools with Three Prong Plugs

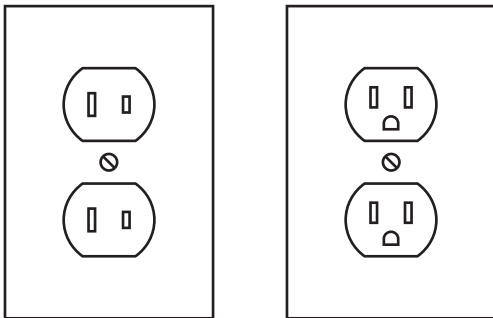


3-Prong Plug and Outlet

1. Tools marked with "Grounding Required" have a three wire cord and three prong grounding plug. The plug must be connected to a properly grounded outlet. If the tool should electrically malfunction or break down, grounding provides a low resistance path to carry electricity away from the user, reducing the risk of electric shock. (See 3-Prong Plug and Outlet.)

2. The grounding prong in the plug is connected through the green wire inside the cord to the grounding system in the tool. The green wire in the cord must be the only wire connected to the tool's grounding system and must never be attached to an electrically "live" terminal. (See 3-Prong Plug and Outlet.)
3. The tool must be plugged into an appropriate outlet, properly installed and grounded in accordance with all codes and ordinances. The plug and outlet should look like those in the preceding illustration. (See 3-Prong Plug and Outlet.)

## Double Insulated Tools: Tools with Two Prong Plugs



Outlets for 2-Prong Plug

1. Tools marked "Double Insulated" do not require grounding. They have a special double insulation system which satisfies OSHA requirements and complies with the applicable standards of Underwriters Laboratories, Inc., the Canadian Standard Association, and the National Electrical Code.
2. Double insulated tools may be used in either of the 120 volt outlets shown in the preceding illustration. (See Outlets for 2-Prong Plug.)

# Biscuit Plate Joiner Safety Warnings (cont.)

## Extension Cords

- Grounded** tools require a three wire extension cord. **Double Insulated** tools can use either a two or three wire extension cord.
- As the distance from the supply outlet increases, you must use a heavier gauge extension cord. Using extension cords with inadequately sized wire causes a serious drop in voltage, resulting in loss of power and possible tool damage. (See Table A.)
- The smaller the gauge number of the wire, the greater the capacity of the cord. For example, a 14 gauge cord can carry a higher current than a 16 gauge cord. (See Table A.)
- When using more than one extension cord to make up the total length, make sure each cord contains at least the minimum wire size required. (See Table A.)
- If you are using one extension cord for more than one tool, add the nameplate amperes and use the sum to determine the required minimum cord size. (See Table A.)
- If you are using an extension cord outdoors, make sure it is marked with the suffix "W-A" ("W" in Canada) to indicate it is acceptable for outdoor use.
- Make sure the extension cord is properly wired and in good electrical condition. Always replace a damaged extension cord or have it repaired by a qualified electrician before using it.
- Protect the extension cords from sharp objects, excessive heat, and damp or wet areas.

RECOMMENDED MINIMUM WIRE GAUGE FOR EXTENSION CORDS* (120/240 VOLT)					
NAMEPLATE AMPERES (at full load)	EXTENSION CORD LENGTH				
	25'	50'	75'	100'	150'
0 – 2.0	18	18	18	18	16
2.1 – 3.4	18	18	18	16	14
3.5 – 5.0	18	18	16	14	12
5.1 – 7.0	18	16	14	12	12
7.1 – 12.0	18	14	12	10	-
12.1 – 16.0	14	12	10	-	-
16.1 – 20.0	12	10	-	-	-

**TABLE A** \* Based on limiting the line voltage drop to five volts at 150% of the rated amperes.

## Symbology

	Double Insulated
	Canadian Standards Association
	Underwriters Laboratories, Inc.
	Volts Alternating Current
	Amperes
	No Load Revolutions per Minute (RPM)

	WARNING marking concerning Risk of Eye Injury. Wear ANSI-approved safety goggles with side shields.
	Read the manual before set-up and/or use.
	WARNING marking concerning Risk of Hearing Loss. Wear hearing protection.
	WARNING marking concerning Risk of Fire. Do not cover ventilation ducts. Keep flammable objects away.
	WARNING marking concerning Risk of Electric Shock. Properly connect power cord to appropriate outlet.

**CHICAGO ELECTRIC®**  
**POWER TOOLS**

## Specifications

Electrical Rating	120V~ / 60Hz / 8.5A
Motor No Load Speed	11,000 RPM
Blade	4" Diameter (Item 38840)
Arbor	7/8" round

**Note:** For additional information regarding the parts listed in the following pages, refer to the Assembly Diagram near the end of this manual.

## Setup - Before Use:



Read the **ENTIRE IMPORTANT SAFETY INFORMATION** section at the beginning of this manual including all text under subheadings therein before set up or use of this product.

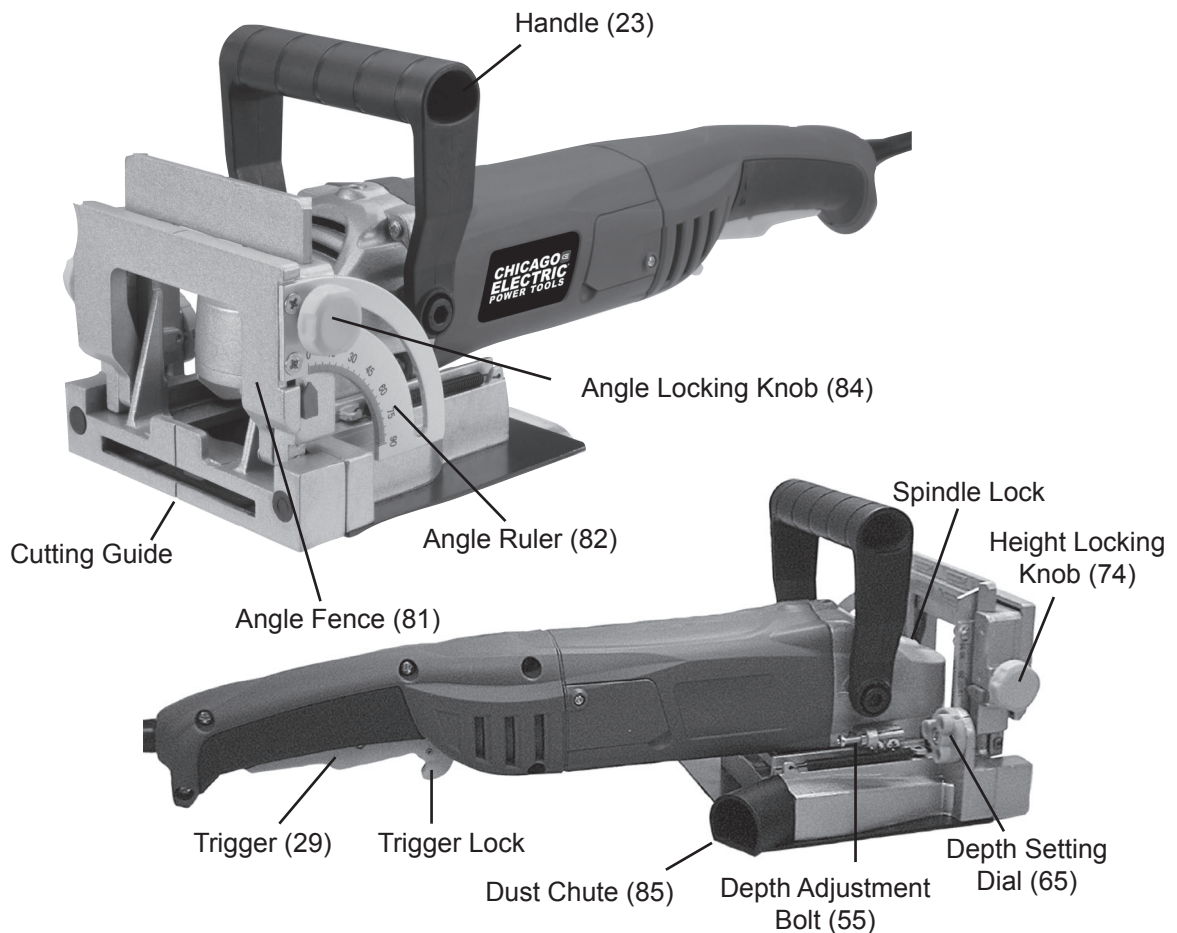
## WARNING

**TO PREVENT SERIOUS INJURY FROM ACCIDENTAL OPERATION:**

Turn the Power Switch of the tool off and unplug the tool from its electrical outlet before assembling or making any adjustments to the tool.

**Note:** For additional information regarding the parts listed in the following pages, refer to the Assembly Diagram near the end of this manual.

## Functions





## Operating Instructions



Read the **ENTIRE IMPORTANT SAFETY INFORMATION** section at the beginning of this manual including all text under subheadings therein before set up or use of this product.

## Tool Set Up

### **WARNING**

**TO PREVENT SERIOUS INJURY FROM ACCIDENTAL OPERATION:**

Turn the Power Switch of the tool off and unplug the tool from its electrical outlet before adjusting the tool or installing accessories.

Make sure that all guards are in place and in proper working order and that all adjustment knobs are tight before operation.

## Changing Blades

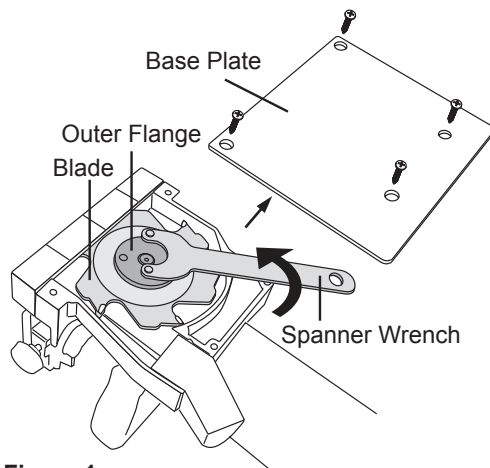


Figure 1

1. Remove the four Screws and the Base Plate on the bottom of the unit.
2. While pressing in on the Spindle Lock Button on the top of the unit, use the Spanner Wrench to loosen (counterclockwise) and remove the Outer Flange and Blade. Do not remove the Inner Flange. Note the direction of the blade teeth when removing the Blade.
3. Place a new Blade and the Outer Flange onto the Spindle making sure the blade teeth are facing the correct direction and the flat side of the Outer Flange is facing outward.
4. Press and hold the Spindle Lock Button and use the Spanner Wrench to tighten (clockwise) the Blade in place.
5. Replace the Base Plate and secure in place with the four Screws.

## Attaching The Dust Bag

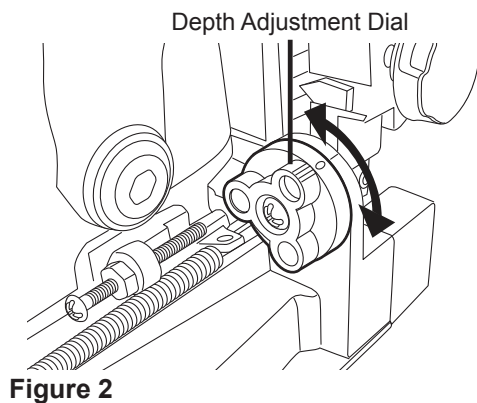
1. Align the Dust Chute with the Dust Port and slide it in place.
2. If the bag is not already attached to the Dust Chute, squeeze together the wire brace ends on the Dust Bag and slide the Bag onto the Dust Chute. Release the wires.
3. To empty the bag, unzip the Zipper at the large end of the bag and empty contents. Zip bag closed.

## Setting the Cutting Depth

The Depth Adjustment Dial sets the cutting depth of the blade. The Dial has settings for three sizes of biscuits (0, 10 or 20), and an "M" setting which is the maximum depth that the tool can cut.

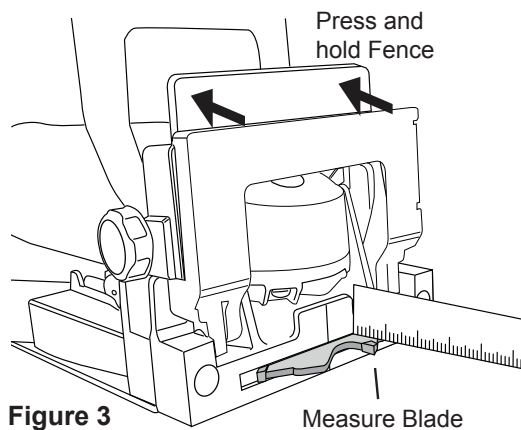
To set the tool for a biscuit size:

Rotate the Depth Adjustment Dial to the desired setting for the biscuit size you will be using.

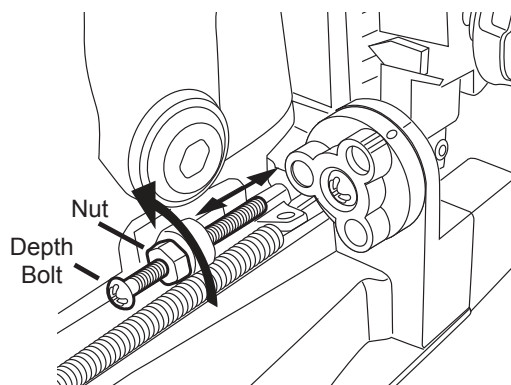


To check the setting for your biscuit size do either of the following:

- Make a sample cut in a scrap piece of wood and check that the biscuit will fit.
- Being careful of the blade, depress the Fence as far as it will go, then measure how far the blade extends.



To adjust the cutting depth:



- Loosen the Nut on the Depth Bolt, then thread the bolt in or out. Adjusting the Bolt closer to the Depth Adjustment Dial makes a shallower cut, while farther away will make a deeper cut.
- Depress the Fence and measure how far the Blade extends. Once the desired setting is reached, tighten the Nut in place.

## Setting the Fence Angle

To adjust the fence angle to anywhere from 0° to 90°:

1. Loosen the Angle Locking Knob and rotate the Angle Fence until the desired angle is set on the Angle Ruler.
2. Tighten the Angle Locking Knob.

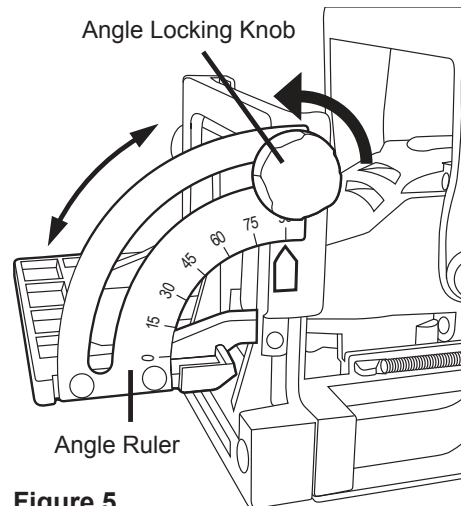


Figure 5

## Setting the Height

The Height fence setting is to measure the cut from the top surface of the workpiece. It is set using both the Angle Fence and the Height Fence.

1. Set the Angle Fence to 90° (see above, Setting the Fence Angle).
2. Loosen the Height Locking Knob and raise or lower the Fence Assembly.
3. Tighten the Height Locking Knob.

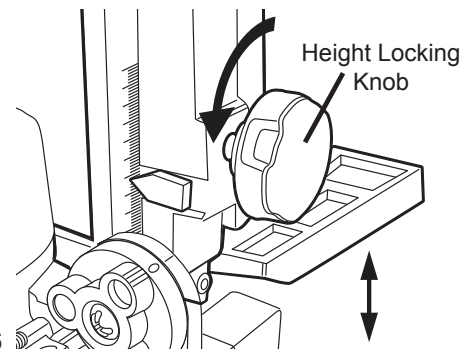


Figure 6

## Work Piece and Work Area Set Up

1. Work piece selection:
  - a. Work piece must be free of foreign objects and loose knots.
  - b. Wet lumber, green (unseasoned) lumber, and pressure treated lumber all have an increased potential for kickback and should only be cut with a blade designed for cutting that lumber. Wear a NIOSH-approved respirator and have appropriate ventilation whenever cutting pressure treated lumber.
2. Designate a work area that is clean and well-lit. The work area must not allow access by children or pets to prevent distraction and injury.
3. Route the power cord along a safe route to reach the work area without creating a tripping hazard or exposing the power cord to possible damage. The power cord must reach the work area with enough extra length to allow free movement while working.
4. Secure loose workpieces using a vise or clamps (not included) to prevent movement while working.
5. Verify that there are no utility lines or hardware in or near the workpiece. This is especially critical for plunge cuts.

# General Operating Instructions

## Locking Trigger

The Biscuit Joiner has a safety lock mechanism to prevent accidentally turning the unit on. You can either turn the tool on and lock it on, or turn it on so that it only stays on while the Trigger is depressed.

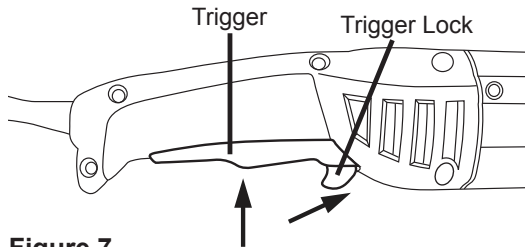


Figure 7

To turn the tool on without locking it, press and hold the Trigger while pushing forward then releasing the Trigger Lock. Continue to depress the Trigger as long as you want it powered. Release the Trigger to turn the power off.

To lock the tool on, press and hold the Trigger while pressing forward on the Trigger Lock. Release the Trigger, then release the Trigger Lock. The Biscuit Joiner will stay on without depressing the Trigger. Press and release the Trigger to turn the unit off.

To make a cut:

1. Secure the piece in place with the cutting mark facing up.
2. Adjust the tool to the desired cutting depth, angle and height.
3. Plug the Biscuit Joiner into a grounded 120V~, 60Hz outlet.
4. Align the cutting guide on the Fence with the cutting mark on the workpiece.
5. Turn on the tool and wait for the Blade to reach full speed.
6. Press into the workpiece to make the cut.
7. When the cut is complete, slide the tool out of the finished slot and release the Trigger.
8. To prevent accidents, turn off the tool and disconnect its power supply after use. Clean, then store the tool indoors out of children's reach.

**Note:** For efficient dust pickup, empty the Dust Bag frequently.

## Operating Tips

Before cutting your workpiece, make a test cut on scraps of wood, and fit them together to ensure the cut is the correct size, depth and location. Adjust the cutting depth as needed (See Setting the Cutting Depth).

This Joiner is set up to cut slots for 3 different sizes of biscuits. Use the largest size biscuit that will fit your operation, usually a workpiece 1/2" thick or larger will use the largest size biscuit (size #20).

### Biscuit Sizes for this Joiner

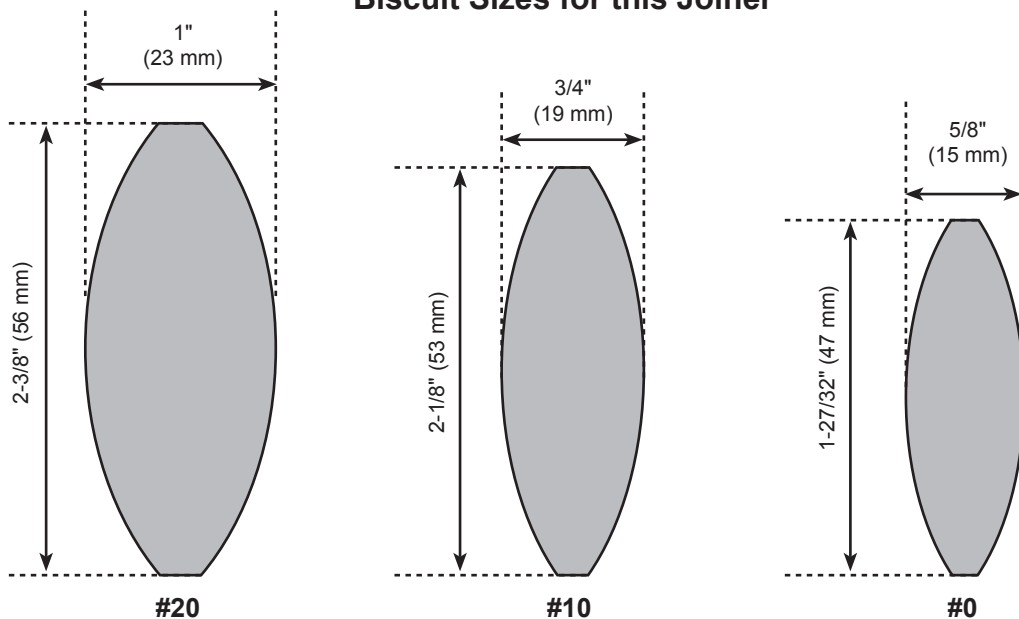
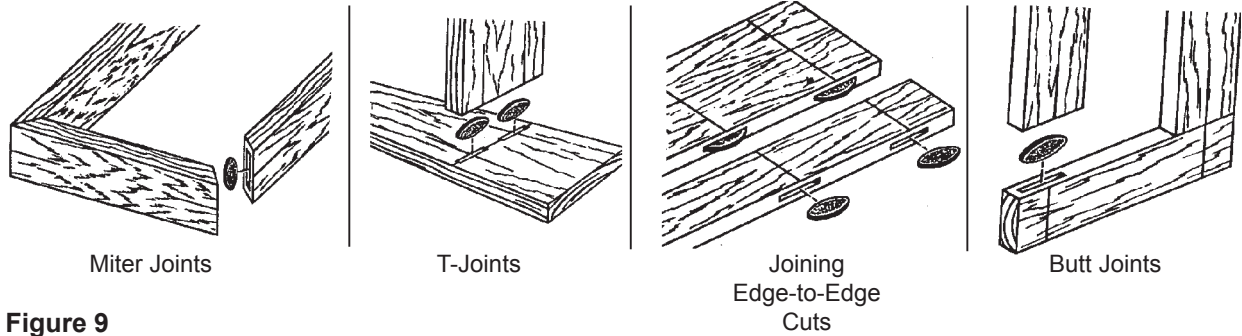


Figure 8

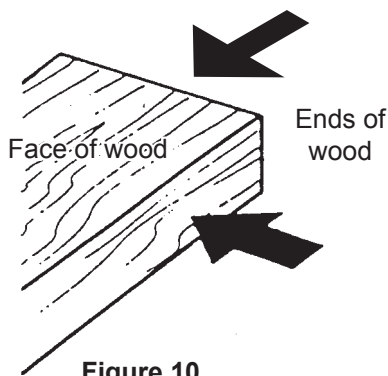
## Operating Tips (cont.)

### Typical Types of Joints

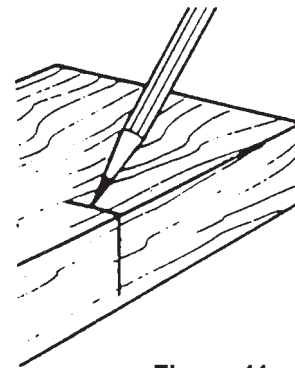


**Figure 9**

Plan the biscuit slot at a point at least 2-1/2" from the outer edge of the board. Allow at least 1" between slots in multiple plate applications for best results. Mark all slots on both boards at the same time to assure proper alignment.

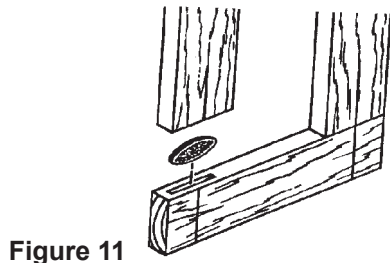


**Figure 10**



**Figure 11**

1. Begin with the Joiner base cutting into the end of the wood, rather than the face as illustrated below.
2. If possible, lay the workpieces as they will be joined together and mark a center line across the join to mark the center of cut to be made.
3. Otherwise, mark the center line of each cut individually.
4. Adjust the fences to the angle and depth needed to make the cut (See Tool Set Up section). Align center line on face plate with the pencil mark on wood then make the cut.



**Figure 11**

## Maintenance and Servicing



Procedures not specifically explained in this manual must be performed only by a qualified technician.

### **⚠️ WARNING**

#### **TO PREVENT SERIOUS INJURY FROM ACCIDENTAL OPERATION:**

Turn the Power Switch of the tool off and unplug the tool from its electrical outlet before performing any inspection, maintenance, or cleaning procedures.

#### **TO PREVENT SERIOUS INJURY FROM TOOL FAILURE:**

Do not use damaged equipment. If abnormal noise or vibration occurs, have the problem corrected before further use.

## Cleaning, Maintenance, and Lubrication


---

**BEFORE EACH USE**, inspect the general condition of the tool. Check for loose screws, misalignment or binding of moving parts, cracked or broken parts, damaged electrical wiring, and any other condition that may affect its safe operation.

#### **AFTER USE:**

1. Remove and empty the Dust Bag.
2. Wearing ANSI-approved safety glasses, use compressed air to blow saw dust out of the tool vents and off the surface of the tool.
3. Wipe external surfaces of the tool with clean cloth.
4. **⚠️ WARNING!** If the supply cord of this power tool is damaged, it must be replaced only by a qualified service technician.

# Troubleshooting

Problem	Possible Causes	Likely Solutions
Tool will not start.	<ol style="list-style-type: none"> <li>1. Cord not connected.</li> <li>2. No power at outlet.</li> <li>3. Tool's thermal reset breaker tripped (if equipped).</li> <li>4. Internal damage or wear. (Carbon brushes or switch, for example.)</li> </ol>	<ol style="list-style-type: none"> <li>1. Check that cord is plugged in.</li> <li>2. Check power at outlet. If outlet is unpowered, turn off tool and check circuit breaker. If breaker is tripped, make sure circuit is right capacity for tool and circuit has no other loads.</li> <li>3. Turn off tool and allow to cool. Press reset button on tool.</li> <li>4. Have technician service tool.</li> </ol>
Tool operates slowly.	Power being reduced by long or small diameter extension cord.	Eliminate use of extension cord. If an extension cord is needed, use one with the proper diameter for its length and load. See <i>Extension Cords</i> in <i>GROUNDING</i> section.
Performance decreases over time.	<ol style="list-style-type: none"> <li>1. Blade dull or damaged.</li> <li>2. Carbon brushes worn or damaged.</li> </ol>	<ol style="list-style-type: none"> <li>1. Keep blade sharp. Replace as needed.</li> <li>2. Have qualified technician replace brushes.</li> </ol>
Excessive noise or rattling.	Internal damage or wear. (Carbon brushes or bearings, for example.)	Have technician service tool.
Overheating.	<ol style="list-style-type: none"> <li>1. Forcing tool to work too fast.</li> <li>2. Blade dull or damaged.</li> <li>3. Blocked motor housing vents.</li> <li>4. Motor being strained by long or small diameter extension cord.</li> </ol>	<ol style="list-style-type: none"> <li>1. Allow tool to work at its own rate.</li> <li>2. Keep blade sharp. Replace as needed.</li> <li>3. Wear ANSI-approved safety goggles and NIOSH-approved dust mask/respirator while blowing dust out of motor using compressed air.</li> <li>4. Eliminate use of extension cord. If an extension cord is needed, use one with the proper diameter for its length and load. See <i>Extension Cords</i> in <i>GROUNDING</i> section.</li> </ol>
 <b>Follow all safety precautions whenever diagnosing or servicing the tool. Disconnect power supply before service.</b>		

**PLEASE READ THE FOLLOWING CAREFULLY**

THE MANUFACTURER AND/OR DISTRIBUTOR HAS PROVIDED THE PARTS LIST AND ASSEMBLY DIAGRAM IN THIS MANUAL AS A REFERENCE TOOL ONLY. NEITHER THE MANUFACTURER OR DISTRIBUTOR MAKES ANY REPRESENTATION OR WARRANTY OF ANY KIND TO THE BUYER THAT HE OR SHE IS QUALIFIED TO MAKE ANY REPAIRS TO THE PRODUCT, OR THAT HE OR SHE IS QUALIFIED TO REPLACE ANY PARTS OF THE PRODUCT. IN FACT, THE MANUFACTURER AND/OR DISTRIBUTOR EXPRESSLY STATES THAT ALL REPAIRS AND PARTS REPLACEMENTS SHOULD BE UNDERTAKEN BY CERTIFIED AND LICENSED TECHNICIANS, AND NOT BY THE BUYER. THE BUYER ASSUMES ALL RISK AND LIABILITY ARISING OUT OF HIS OR HER REPAIRS TO THE ORIGINAL PRODUCT OR REPLACEMENT PARTS THERETO, OR ARISING OUT OF HIS OR HER INSTALLATION OF REPLACEMENT PARTS THERETO.

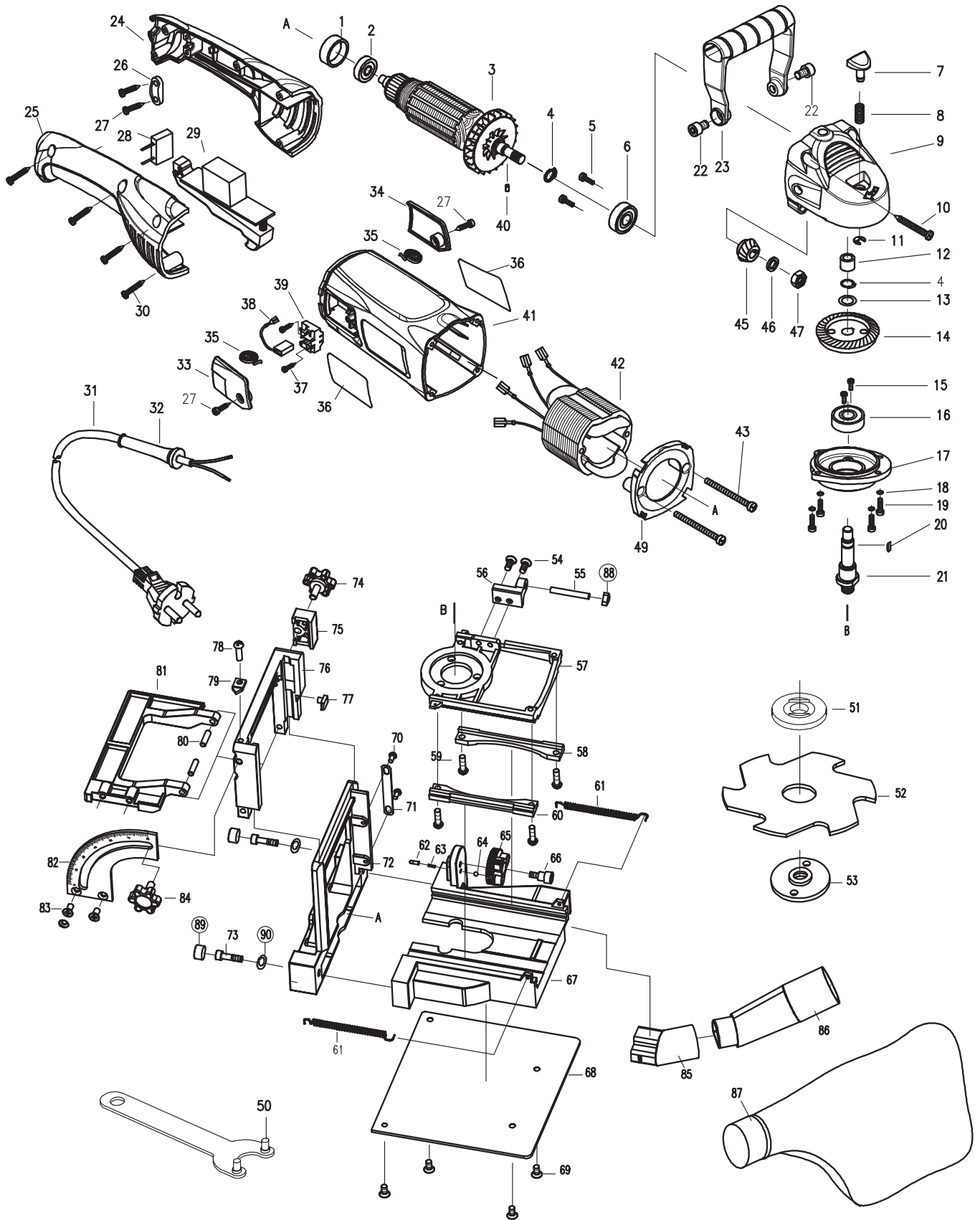
**Parts List**

Part	Description	Qty
1	Bearing Set	1
2	Bearing 60017	1
3	Armature	1
4	Check Ring φ10	2
5	Screw M4x10	2
6	Bearing 60100	1
7	Spindle Lock Button	1
8	Spring	1
9	Gear Box	1
10	Screw	4
11	Check Ring φ5	1
12	Bearing φ12Xφ8X10	1
13	Spring Washer φ10	1
14	Gear	1
15	Screw M4X12	2
16	Bearing 80201	1
17	Front Cap	1
18	Spring Washer φ4	11
19	Screw M4X14	2
20	Woodruff-Key 3X10	1
21	Spindle	1
22	Screw M6X14	2
23	Upper Handle	1
24	Handle(L)	1
25	Handle(R)	1
26	Cord Clamp	1
27	Screw ST4.2X13	2
28	Capacitor	1
29	Trigger	1
30	Screw ST4.2X16	5
31	Cord Plug	1
32	Cord Protector	1
33	Brush Cap (R)	1
34	Brush Cap(L)	1
35	Brush Spring	1
36	Label	2
37	Screw ST3.5X10	4
38	Brush	2
39	Brush Holder	2
40	Roller φ3X4.9	1
41	Housing	1
42	Stator	1
43	Screw M4X55	2
45	Pinion	1

Part	Description	Qty
46	Spring Washer φ8	1
47	Nut M8	1
49	Fan Guide	1
50	Spanner Wrench	1
51	Inner Flange	1
52	Blade	1
53	Outer Flange	1
54	Flat Screw M4X8	2
55	Depth Setting Bolt M4X25	1
56	Depth Base Block	1
57	Depth Slide Plate	1
58	Guide Bar 1	1
59	Screw M4X14	4
60	Guide Bar 2	1
61	Spring	2
62	Set Screw M4	1
63	Compressing Spring	1
64	Steel Ball φ3	1
65	Depth Adjustment Dial	1
66	Shoulder Screw M5X12	1
67	Slide Plate	1
68	Base Plate	1
69	Flat Screw M4X6	4
70	Screw M3X6	2
71	Depth Mark	1
72	Support Stand Board	1
73	Allen Bolt M4X16	2
74	Height Locking Knob	1
75	Pressed Block	1
76	Height Fence	1
77	Depth Pointer	1
78	Screw M4X14	1
79	Angle Pointer	1
80	Dowel	2
81	Angle Fence	1
82	Angle Ruler	1
83	Sink Screw	2
84	Angle Locking Knob	1
85	Dust Port	1
86	Dust Chute	1
87	Dust Bag	1
88	Nut	1
89	Cap	2
90	Spring Washer 65Mn(φ4)	2



# Assembly Diagram



SAFETY

SETUP

OPERATION

MAINTENANCE

**Record Product's Serial Number Here:** \_\_\_\_\_

**Note:** If product has no serial number, record month and year of purchase instead.

**Note:** Some parts are listed and shown for illustration purposes only, and are not available individually as replacement parts.

## Limited 90 Day Warranty

Harbor Freight Tools Co. makes every effort to assure that its products meet high quality and durability standards, and warrants to the original purchaser that this product is free from defects in materials and workmanship for the period of 90 days from the date of purchase. This warranty does not apply to damage due directly or indirectly, to misuse, abuse, negligence or accidents, repairs or alterations outside our facilities, criminal activity, improper installation, normal wear and tear, or to lack of maintenance. We shall in no event be liable for death, injuries to persons or property, or for incidental, contingent, special or consequential damages arising from the use of our product. Some states do not allow the exclusion or limitation of incidental or consequential damages, so the above limitation of exclusion may not apply to you. THIS WARRANTY IS EXPRESSLY IN LIEU OF ALL OTHER WARRANTIES, EXPRESS OR IMPLIED, INCLUDING THE WARRANTIES OF MERCHANTABILITY AND FITNESS.

To take advantage of this warranty, the product or part must be returned to us with transportation charges prepaid. Proof of purchase date and an explanation of the complaint must accompany the merchandise. If our inspection verifies the defect, we will either repair or replace the product at our election or we may elect to refund the purchase price if we cannot readily and quickly provide you with a replacement. We will return repaired products at our expense, but if we determine there is no defect, or that the defect resulted from causes not within the scope of our warranty, then you must bear the cost of returning the product.

This warranty gives you specific legal rights and you may also have other rights which vary from state to state.

**CHICAGO  ELECTRIC®**  
**POWER TOOLS**

3491 Mission Oaks Blvd. • PO Box 6009 • Camarillo, CA 93011 • (800) 444-3353