



Operation guide

High Capacity Stacker-G1

A series of horizontal lines forming a ruled area for notes or additional information, spanning the width of the page.

Copyright

© 2014 by Canon Inc. All Rights Reserved.

No part of this publication may be reproduced or transmitted in any form or by any means, electronic or mechanical, including photocopying and recording, or by any information storage or retrieval system without the prior written permission of Canon Inc.

© 2014 Océ. All rights reserved.

No part of this work may be reproduced, copied, adapted, or transmitted in any form or by any means without written permission from Océ.

Océ makes no representation or warranties with respect to the contents hereof and specifically disclaims any implied warranties of merchantability or fitness for any particular purpose.

Furthermore, Océ reserves the right to revise this publication and to make changes from time to time in the content hereof without obligation to notify any person of such revision or changes.

Contents

Chapter 1

Preface	5
Notes for the reader.....	6

Chapter 2

Components and their functions	7
Description of the main parts.....	8
Description of the stacker control panel.....	10

Chapter 3

Basic instructions	13
Turn the stacker on.....	14
Turn the stacker off.....	15
Eject a stack manually.....	16

Chapter 4

Use the stacker	17
Filling scenarios.....	18
Change the default stacker settings.....	19
Set the maximum stack height.....	21
Set the minimum filling level.....	22
Examples of using the Maximum stack height and the Minimum filling level settings.....	23

Chapter 5

Troubleshooting	27
Error location labels.....	28
Remove an error sheet from the internal error tray (A1).....	30
Clear a paper jam in the input paper path (A2-A5).....	31
Clear a paper jam in the input paper path of the registration unit (A6-A7).....	33
Clear a paper jam in the paper path (B1).....	35
Clear a paper jam in the horizontal paper path (B2-B5).....	37
Clear a paper jam at the flip wheel (C1).....	39

Chapter 6

Options	41
Use the EasyLift to unload the stacker.....	42

Appendix A

Specifications	45
Specifications.....	46

Index	47
--------------------	-----------

Chapter 1

Preface

Notes for the reader

Introduction

This manual helps you to use the High Capacity Stacker-G1 . The manual contains a description of the product and guidelines to use and operate the High Capacity Stacker-G1 .

Definition

Attention-Getters





Parts of this manual require your special attention. These parts can provide the following:

- Additional general information, for example, information that is useful when you perform a task.
- Information to prevent personal injuries or property damage.

Symbols used in this manual

The following symbols are used in this manual to explain procedures, restrictions, handling precautions, and instructions that should be observed for safety.

Overview of the attention-getters

Word	Icon	Indicates
WARNING		Indicates a warning concerning operations that may lead to death or injury to persons if not performed correctly. To use the machine safely, always pay attention to these warnings.
CAUTION		Indicates a caution concerning operations that may lead to injury to persons if not performed correctly. To use the machine safely, always pay attention to these cautions.
IMPORTANT		Indicates operational requirements and restrictions. Be sure to read these items carefully to operate the machine correctly and to avoid damaging the machine or property.
NOTE		Indicates a clarification of an operation or contains additional explanations for a procedure. Reading these notes is highly recommended.
-		Indicates an operation that must not be performed. Read these items carefully and make sure not to perform the described operations.

Chapter 2

Components and their functions

Description of the main parts

Illustration

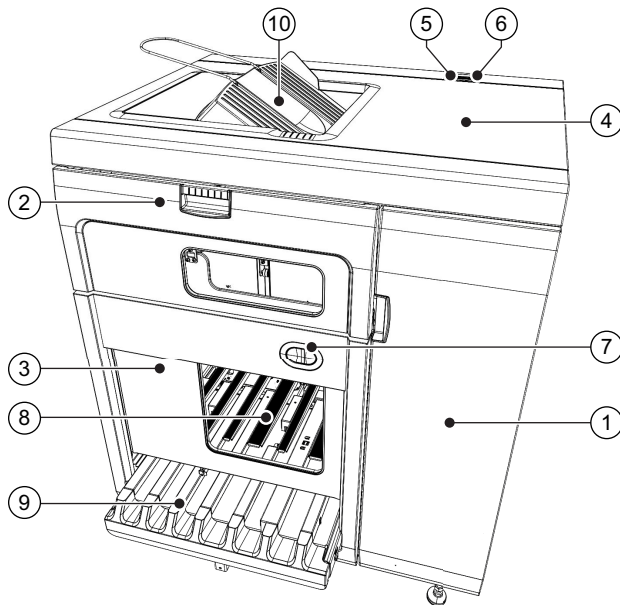

[1] The main parts of High Capacity Stacker-G1

Main parts

	Part	Description
1	Front door	The front door gives access to the registration unit and the error locations A1-A7.
2	Front cover	The front cover gives access to the flip rings and error location C1 (flip wheel).
3	Slide door	The slide door covers the tray and the stack inside the stacker.
4	Top cover	The top cover gives access to the error locations B1-B5.
5	Power switch cover	The optional power switch cover shields the power switch.
6	Power switch	The optional power switch turns the machine on or off.
7	Stacker control panel	The stacker control panel contains status LEDs, error LEDs and the eject button.
8	Stack tray	The stack tray receives the prints and transfers the stack of prints to the eject tray. After the transfer, the stack tray moves back up and the filling can continue. ▶

	Part	Description
9	Eject tray	The eject tray receives the stack from the stack tray. Then the eject tray moves horizontally out of the stacker. When the eject tray is outside the stacker, you can remove the stack. In the meantime, the filling of the stack tray can continue. When you empty the eject tray regularly, the printer can continue printing. This maximizes the productivity.
10	Top tray	The top tray is an output location for small jobs, proof prints, error prints and unused cyclic media.

Related information

[Description of the stacker control panel on page 10](#)

Description of the stacker control panel

Illustration

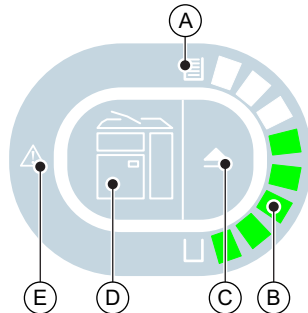

[2] The items of the stacker control panel

Description of the stacker control panel

Item	Description
A	Filling level indicator (off, orange or red).
B	Stack height indicators.
C	Eject button. The eject button LED can have the following statuses: <ul style="list-style-type: none"> • Off: Normal situation • Blinking slowly (green): The stack will be ejected at the next possible set boundary. Therefore, the stack will usually contain complete sets. • Blinking fast (green): The stack will be ejected as soon as possible. Therefore, the stack can contain incomplete sets. • Permanent red: An error has occurred that requires opening the slide door.
D	Error location indicators.
E	Error indicator.

Status LEDs on the stacker control panel

Status LEDs

Status	Description
	No stack height indicator is lit. The stack tray is empty. When the machine is off or in low power mode, the LEDs are off.

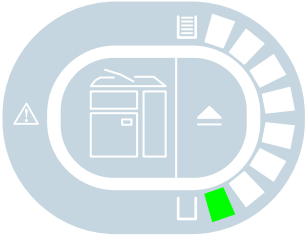
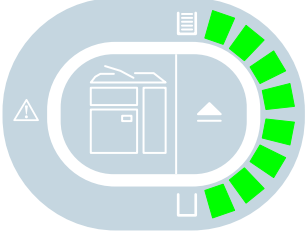
Status	Description
	1 stack height indicator is lit. The stack tray contains at least 1 sheet.
	All stack height indicators are lit. The stack height comes close to the factory default value of 302 mm (11.9"). Stacks with a height of maximum 302 mm (11.9") are always ejected properly. For higher stacks, there is a risk that the top sheets touch the underside of the slide door when ejected.

Error LEDs on the stacker control panel

Error LEDs

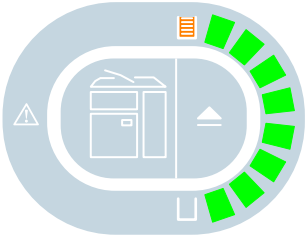
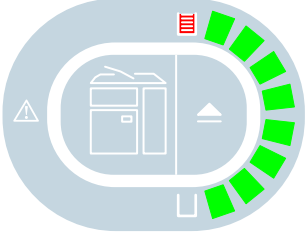
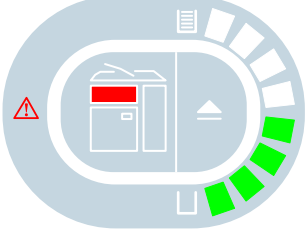
Error	Description
	Paper tray icon is orange. The stack height exceeds 302 mm (11.9"). This is possible when the maximum stack height and the filling level are set to a higher level than the factory default value, for example.
	Paper tray icon is red. Operator intervention is required. The eject tray must be emptied before printing continues. The green LEDs in the illustration are just an example. The red icon does not depend on the number of LEDs lit.
	An error or paper jam has occurred at the position indicated in red. In this example, the paper jam has occurred at the flip wheel (C1).

Related information

Description of the main parts on page 8

Chapter 3

Basic instructions

Turn the stacker on

The power switch is optional. If the switch is missing, the high capacity stacker is turned on automatically when the printer is turned on.



CAUTION

Never plug in the power plug while your hands are wet. Doing so creates the risk of electric shock.

Illustration

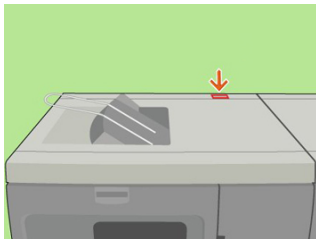

[3] The location of the power switch

Procedure

1. Confirm that the power plug is plugged securely into a power outlet.
2. Open the power switch cover.
3. Press the ON side (I) of the power switch to turn the stacker on.
4. Close the power switch cover.

Turn the stacker off

The power switch is optional. If the switch is missing, the high capacity stacker is turned off automatically when the printer is turned off.



CAUTION

Never unplug the power plug while your hands are wet. Doing so creates the risk of electric shock.

Illustration

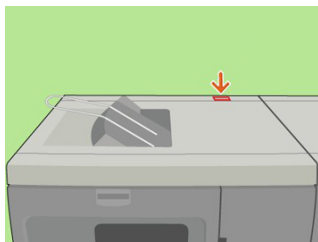

[4] The location of the power switch

Procedure

1. Open the power switch cover.
2. Press the OFF side (O) of the power switch to turn the stacker off.
3. Close the power switch cover.
4. If required, disconnect the power plug to cut off the power supply to the stacker completely.

Eject a stack manually

Eject a stack

When you press the eject button on the stacker	Then
1x The eject button on the stacker control panel blinks slowly (green).	The stack will be ejected on the next possible set boundary. Then the filling of the stacker continues. Therefore, the stack will usually contain complete sets.
2x The eject button on the stacker control panel blinks fast (green).	The stack will be ejected as soon as possible. Then the filling of the stacker continues. Therefore, the stack can contain incomplete sets.



NOTE

To stop a job completely, you must use the Stop button on the printer control panel.

Chapter 4

Use the stacker (PRISMAsync)

Filling scenarios

Filling scenarios

Scenario	Description	Where to define the settings?
Filling with default settings	The stack tray is filled until the stack reaches the factory default height of 302 mm (11.9"). Then the stack is ejected.	
Next job, next tray	Each new job is delivered to an empty stack tray.	On the printer control panel: [System] -> [Setup] -> [Workflow profile] -> [Output] -> [Next output tray] -> [After each job].
Maximum tray filling	To optimize the productivity, you can set the stack height to maximum 355 mm (14.0"). Due to curl and an uneven toner coverage of sheets, a slanting stack can occur. This can result in sheets falling off the stack during the ejection because these sheets can touch the underside of the slide door. See the section 'Set the maximum stack height'.	In the Settings Editor: [Preferences] -> [Print job defaults] -> [Stacker] -> [Maximum stack height].
Limit the stack height	According to your needs, if stacks must fit into boxes for example, you can define a stack height below the factory default value. See the section 'Set the maximum stack height'.	In the Settings Editor: [Preferences] -> [Print job defaults] -> [Stacker] -> [Maximum stack height].
Filling level	This setting is used to keep sets together. See the section 'Set the minimum filling level'.	In the Settings Editor: [Preferences] -> [Print job defaults] -> [Stacker] -> [Minimum filling level].

Change the default stacker settings

Introduction

In the Settings Editor on the PRISMAsync controller, a key operator can define a number of default stacker settings ([Preferences] -> [Print job defaults] - [Stacker]). These settings are described below. Some of these default settings can be overruled in an application, on the printer operator panel and in the printer driver.



NOTE

The [Stacker] section also displays settings for other stackers. Only for the High Capacity Stacker-G1 the settings described below are applicable.



NOTE

Changing these settings requires the key operator password for the Settings Editor.

Settings for the stacker

Setting	Description
[Stacker]	This read-only setting indicates whether a stacker is present.
Feed edge	The feed edge is the direction in which the printed documents are delivered to the stack tray, either [Long-edge feed (LEF)] or [Short-edge feed (SEF)]. You can only select the feed edge for A4-like or LTR-like media. The feed edge for large media, A3 and Tabloid for example, is always [Short-edge feed (SEF)]. You can set the feed edge for both the top tray and the stack tray. Factory default value: [Long-edge feed (LEF)].
Face orientation	The face orientation defines whether the front side of the printed documents points up or down. [Face down] means that the front side of the sheet points down. You can set the face orientation for both the top tray and the stack tray. Factory default value: [Face down].
Header orientation	The header orientation defines whether the header of the printed documents points towards the back or towards the front of the printer. [Header-up] means that the header points towards the back of the printer. You can set the header orientation for both the top tray and the stack tray. Factory default value: [Header-up].
Reverse order	The sheet order defines how the sheets are delivered to the tray. [First sheet first] means that the first sheet is delivered first. You can set the reverse order for both the top tray and the stack tray. Factory default value: [First sheet first].
Offset stacking	Offset stacking means that each set is shifted on top of the previous set to create a visible distinction between sets. You can define a value from 0-15 mm (0-0.6") for the stack tray only. When you set the value to 0 you get the straightest stacks possible. When the value is 0 while offset stacking is enabled, for example in a workflow profile, the offset stacking setting will be overruled. The sheets will be stacked without offset. Factory default value: 15 mm (0.6").
[Minimum filling level]	See the section 'Set the minimum filling level'. ▶

Setting	Description
[Maximum stack height]	See the section 'Set the maximum stack height'.

Procedure

1. Access the Settings Editor on the PRISMAsync controller.
2. Click [Preferences] - [Print job defaults].
3. Scroll down to the [Stacker] section.
4. Click the setting you want to change.
5. Change the value.
6. Click [OK].

Set the maximum stack height

Introduction

The maximum stack height is 355 mm (14") or 3,000 sheets A4/LTR (80 g/m² / 20 lb bond). However, to guarantee a safe ejection of the stack, the factory default is set to 302 mm (11.9"). Depending on your needs, you can set the maximum stack height to a higher or lower value. When the stack reaches the specified height, the stack is ejected.

Higher value

A higher value can be useful when you want to make optimal use of the output capacity in case of unattended printing, for example.

However, when you set the value close to the maximum value, there is an increasing risk that sets get split when the stack tray is almost full. Furthermore, curled paper or a slightly slanting stack can touch the underside of the slide door during the ejection. This can result in sheets falling off the stack.

Lower value

A lower value can be useful in the following situations, for example.

- When a stack must fit into a box.
- When a stack must fit the processable amount of sheets of specific offline finishing.
- When specific prints, such as curling prints or prints with an uneven toner coverage, result in slanting stacks.
- When a stack becomes too heavy to lift manually.

Next job, next tray



NOTE

When the "next job, next tray" filling scenario is active (on the printer operator panel: [System] -> [Setup] -> [Workflow profile] -> [Output] -> [Next output tray] -> [After each job]), the stack will be ejected when the specified stack height is reached. The controller does not make sure that sets are kept together.

Procedure

1. Access the Settings Editor on the PRISMAsync controller.
2. Enter the key operator password.
3. Click [Preferences] -> [Print job defaults].
4. Scroll down to the [Stacker] section.
5. Click [Maximum stack height].
6. Enter the desired stack height.
You can enter a value from 10 mm to 355 mm (0.4" to 14.0"). The factory default value is 302 mm (11.9").
7. Click [OK].

Set the minimum filling level

Introduction



NOTE

The [Minimum filling level] setting is only applied when, on the printer control panel, the [Next output tray] setting is set to [When tray is full] (under [System] -> [Setup] -> [Workflow profile] -> [Output]).

Purposes

The [Minimum filling level] setting has the following purposes.

- Maximize the time that the printer can run unattended.
- Keep sets together.

Scenarios

The minimum filling level is a percentage of the specified maximum stack height. The following scenarios can occur.

Scenarios to keep sets together

When	Then
A job is completed before the minimum filling level is reached	The next job is delivered to the same output tray.
A job exceeds the minimum filling level	The stack will be ejected after the job is ready.
A set is completed before the minimum filling level is reached	The next set is delivered to the same output tray.
A set exceeds the minimum filling level	The controller calculates whether the next set can be added to the stack. If the total stack height, including the next set, is still lower than the maximum stack height, then the next set is added to the stack. If the total stack height, including the next set, will become higher than the maximum stack height, then the next set is added to the next output tray available. The stack will be ejected after the current set is ready.

Procedure

1. Access the Settings Editor on the PRISMAsync controller.
2. Enter the key operator password.
3. Click [Preferences] -> [Print job defaults].
4. Scroll down to the [Stacker] section.
5. Click [Minimum filling level].
6. Enter the desired filling level.
You can define a percentage from 1% - 100% in steps of 1%. The factory default value is 80%. This value makes sure that, in most cases, sets are kept together.
7. Click [OK].

Examples of using the [Maximum stack height] and the [Minimum filling level] settings

Example 1 - Fill a box

Assumption

In the Settings Editor, the [Maximum stack height] setting is set to 302 mm (11.9").

In the Settings Editor, the [Minimum filling level] setting is set to 80%.

1 job using plain paper with a stack height > 302 mm (11.9").

What happens?

If you want to fill a box, you can limit the maximum stack height to the height of that box. The stacker:

- Fills the stack tray up to the specified height of 302 mm (11.9").
- Ejects the stack.
- Puts the rest of the job on the next output tray available.

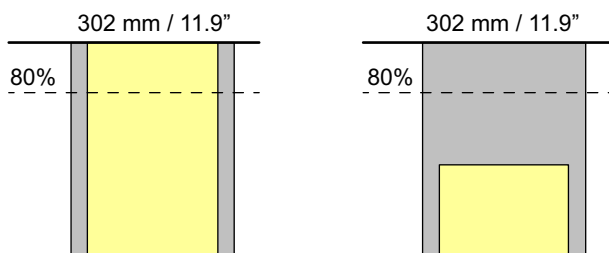

Example 2 - Handle a slanting stack

Assumption

In the Settings Editor, the [Maximum stack height] setting is set to 250 mm (9.8").

In the Settings Editor, the [Minimum filling level] setting is set to 80%.

1 job using punched media with a stack height > 302 mm (11.9").

What happens?

Punched media can create a slanting stack. To prevent sheets from sliding off the stack, you can limit the maximum stack height to 250 mm (9.8"), for example. The stacker:

- Fills the stack tray up to the specified height of 250 mm (9.8").
- Ejects the stack.
- Puts the rest of the job on the next output tray available.

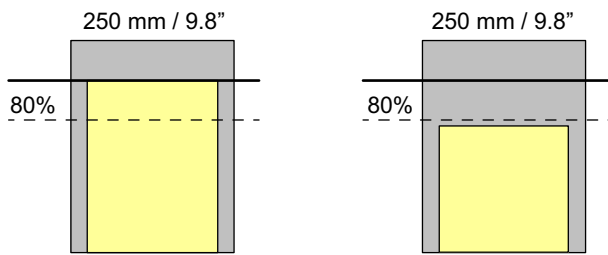

Example 3 - Keep sets together

Assumption

In the Settings Editor, the [Maximum stack height] setting is set to 302 mm (11.9").

In the Settings Editor, the [Minimum filling level] setting is set to 80%.

1 job with a stack height of 100 mm (3.9").

4 copies required.

What happens?

The sets are stacked. At the end of each set, the controller calculates whether the next set will fit. When the next set will not fit, the set is delivered to the next output tray available.

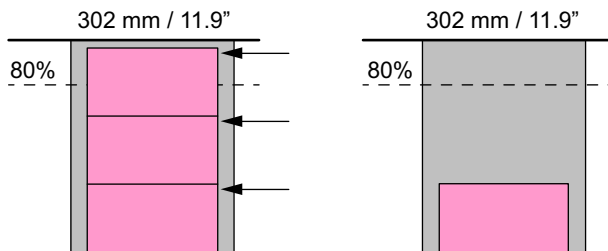

Example 4 - Keep jobs together

Assumption

In the Settings Editor, the [Maximum stack height] setting is set to 302 mm (11.9").

In the Settings Editor, the [Minimum filling level] setting is set to 80%.

4 different jobs with a stack height of 100 mm (3.9") each.

1 copy required.

What happens?

The jobs are stacked. At the end of each job, the controller calculates whether the next job will fit. When the next job will not fit, the job is delivered to the next output tray available.

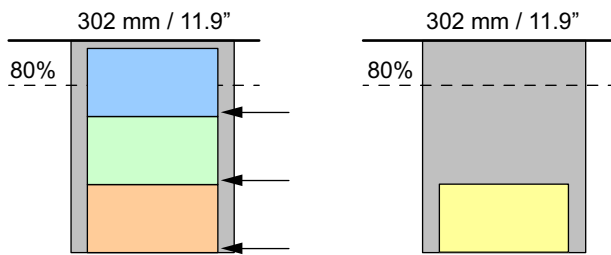

Example 5 - Two jobs exceed the maximum stack height

Assumption

In the Settings Editor, the [Maximum stack height] setting is set to 302 mm (11.9").

In the Settings Editor, the [Minimum filling level] setting is set to 80%.

On the printer operator panel, the workflow profile setting [Next output tray] is set to [When tray is full].

2 different jobs with a stack height > 302 mm (11.9") each.

1 copy required

What happens?

Job 1 is stacked until a height of 302 mm (11.9") is reached. Then the stack with the partial job 1 is ejected. The rest of job 1 is deposited on the stack tray. After you empty the stacker, job 2 will be deposited the same way. Job 2 will not be deposited on top of job 1. The keep-jobs-together function prevails.

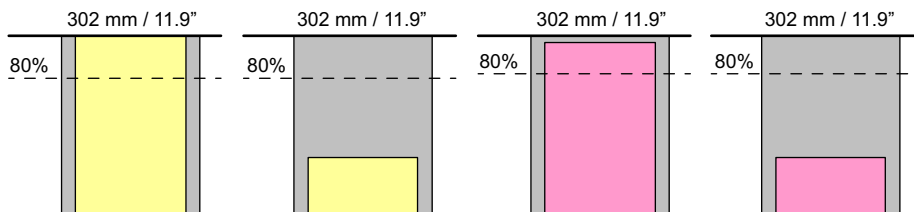

Related information

[Set the maximum stack height on page 21](#)

[Set the minimum filling level on page 22](#)

Chapter 5

Troubleshooting

Error location labels

Introduction

The stacker has various labels inside that indicate error locations. You can access these locations to remove error sheets or jammed paper.

Illustration

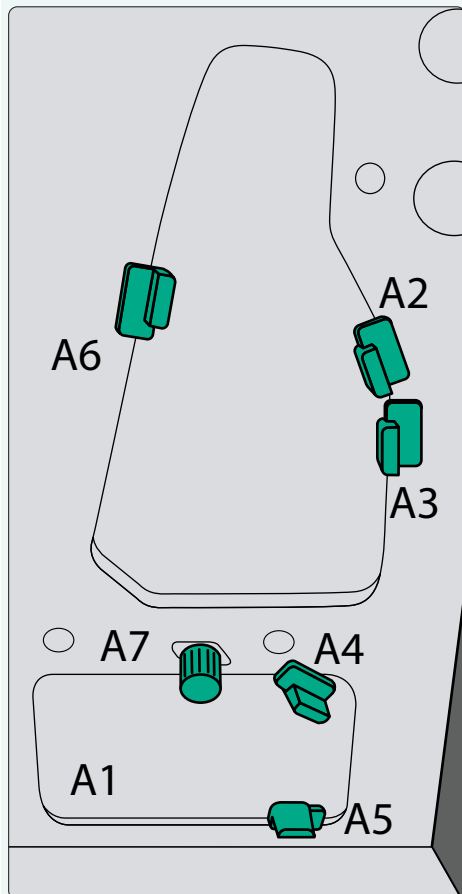

[5] Example of a label inside the stacker

Error codes and locations

Overview of error codes and locations

Error codes	Error locations	How to access the error locations
A1-A7	Paper path	Open the front door.
B1-B5	Paper path	Open the top cover.
C1	Flip wheel	Open the front cover.
No label, only indicated on the stacker control panel	Stack area	Press the eject button.

Remove an error sheet from the internal error tray (A1)

When to do

A red LED lights up at the stacker control panel.

Illustration

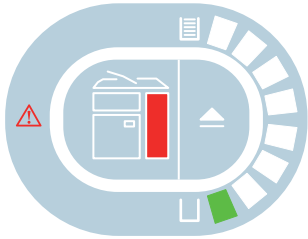

[6] Indication at the stacker control panel

Remove an error sheet from A1

Step	Action	Illustration
1	Open the front door.	
2	Remove the sheets from the internal error tray (A1).	
3	Close the front door.	

Clear a paper jam in the input paper path (A2-A5)

When to do

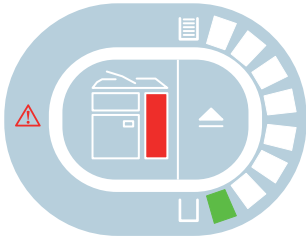

A red LED lights up at the stacker control panel.

Illustration

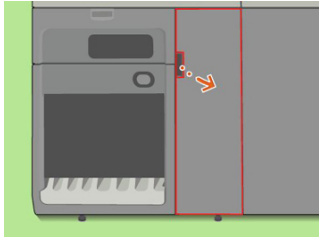
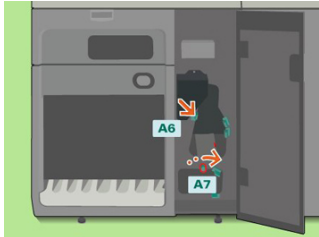

[7] Indication at the stacker control panel

Clear a paper jam at A2-A5

Step	Action	Illustration
1	Open the front door.	
2	Turn A7 to remove jammed paper.	 <p>CAUTION When you turn the knob, be careful not to get your fingers caught.</p>
3	Open A2, A3, A4 and A5 to remove the jammed paper.	

Clear a paper jam in the input paper path (A2-A5)

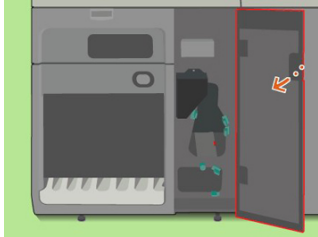
Step	Action	Illustration
4	Close the front door.	

Clear a paper jam in the input paper path of the registration unit (A6-A7)

When to do

A red LED lights up at the stacker control panel.

Illustration

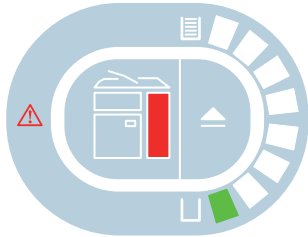

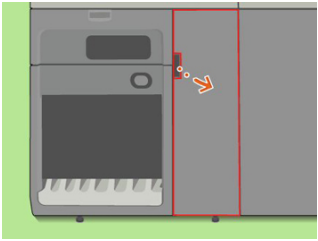
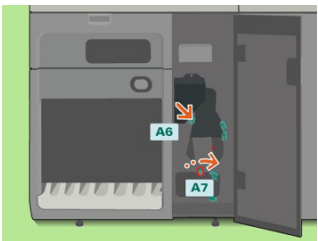

[8] Indication at the stacker control panel

Clear a paper jam at A6-A7

Step	Action	Illustration
1	Open the front door.	 An illustration of the front door of the registration unit being opened. A red vertical line indicates the door's position, and an orange arrow points to the right, showing the door swinging open.
2	Turn A7 to remove the jammed paper.	 An illustration showing the interior of the registration unit with the front door open. A hand is shown turning a knob labeled 'A7' to rotate a component and remove jammed paper. Another knob labeled 'A6' is also visible.

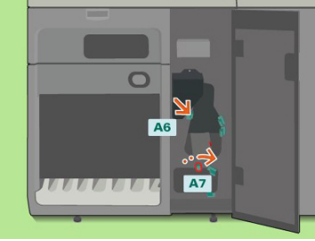
CAUTION
 When you turn the knob, be careful not to get your fingers caught.

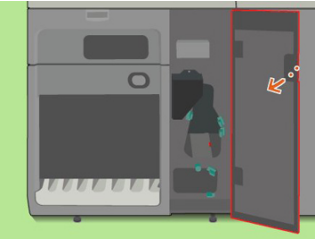
Step	Action	Illustration
3	Remove the jammed paper from A6.	 <p>CAUTION  If the lower input paper path of the registration unit also contains jammed paper, only authorized and trained persons are allowed to remove the jammed paper.</p>
4	Close the front door.	

Clear a paper jam in the paper path (B1)

When to do

A red LED lights up at the stacker control panel.

Illustration

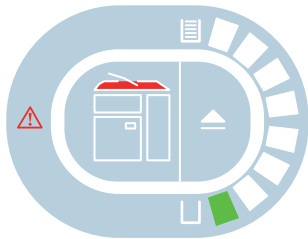

[9] Indication at the stacker control panel

Clear a paper jam at B1

Step	Action	Illustration
1	Open the top cover.	
2	Open B1 and remove the jammed paper.	

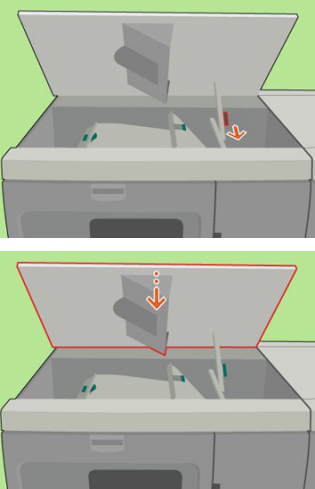
Step	Action	Illustration
3	Close the top cover.	 <p>CAUTION When you close the top cover, be careful not to get your fingers caught.</p>

Clear a paper jam in the horizontal paper path (B2-B5)

When to do

A red LED lights up at the stacker control panel.

Illustration

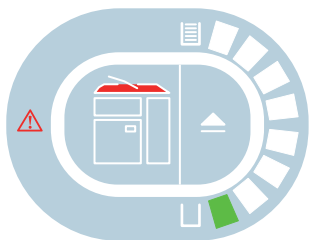

[10] Indication at the stacker control panel

Clear a paper jam at B2-B5

Step	Action	Illustration
1	Open the top cover.	
2	Open B2, B3, B4 and B5 to remove the jammed paper.	

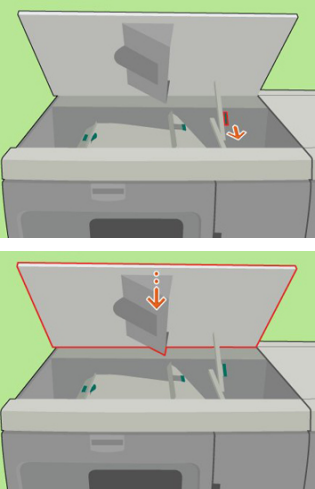
Step	Action	Illustration
3	Close the top cover.	 <p>CAUTION When you close the top cover, be careful not to get your fingers caught.</p>

Clear a paper jam at the flip wheel (C1)

When to do

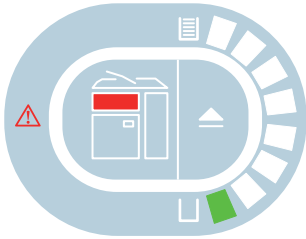

A red LED lights up at the stacker control panel.

Illustration

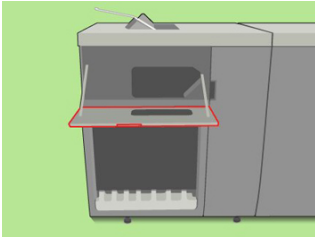

[11] Indication at the stacker control panel

Clear a paper jam at C1

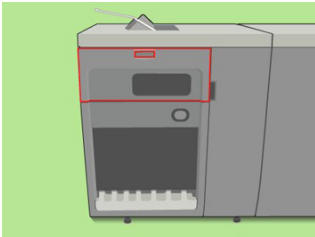
Step	Action	Illustration
1	Open the front cover.	
2	Open C1 and remove the jammed paper from the flip wheel.	 
3	Close the front cover.	

Chapter 6

Options

Use the EasyLift to unload the stacker

Introduction

The optional EasyLift is a manual device that helps you to remove a stack of paper more easily.



NOTE

The EasyLift is delivered with a user guide. Refer to the EasyLift user guide for more information. This section contains a brief description for reference only.

Examples of stack weights

The tables below give an indication of the weights of stacks of paper.

- Green = OK to lift manually
- Red (strike-through) = too heavy to lift manually

Illustration

g/m ²			x100	x500	x1000	x2000
80	A4	210 mm x 297 mm	0.5 kg	2.5 kg	5.0 kg	10.0 kg
80	A3	297 mm x 420 mm	1.0 kg	5.0 kg	10.0 kg	20.0 kg
90	A4	210 mm x 297 mm	0.6 kg	2.8 kg	5.6 kg	11.2 kg
90	A3	297 mm x 420 mm	1.1 kg	5.6 kg	11.2 kg	22.4 kg
120	A4	210 mm x 297 mm	0.8 kg	3.8 kg	7.5 kg	15.0 kg
120	A3	297 mm x 420 mm	1.5 kg	7.5 kg	15.0 kg	30.0 kg
200	A4	210 mm x 297 mm	1.3 kg	6.3 kg	12.5 kg	25.0 kg
200	A3	297 mm x 420 mm	2.5 kg	12.5 kg	25.0 kg	50.0 kg
250	A4	210 mm x 297 mm	1.6 kg	7.8 kg	15.6 kg	31.2 kg
250	A3	297 mm x 420 mm	3.1 kg	15.6 kg	31.2 kg	62.4 kg
300	A4	210 mm x 297 mm	1.9 kg	9.5 kg	19.0 kg	38.0 kg
300	A3	297 mm x 420 mm	3.7 kg	18.7 kg	37.4 kg	74.8 kg

[12] The weight of stacks of 100, 500, 1,000 and 2,000 sheets - Examples for ISO media

lbs			x100	x500	x1000	x2000
20 lb Bond	LTR	8.5" x 11"	1.0 lbs	5.0 lbs	10.0 lbs	20.0 lbs
20 lb Bond	Tabloid	11" x 17"	2.0 lbs	10.0 lbs	20.0 lbs	44.0 lbs
24 lb Bond	LTR	8.5" x 11"	1.2 lbs	6.0 lbs	12.0 lbs	24.0 lbs
24 lb Bond	Tabloid	11" x 17"	2.4 lbs	12.0 lbs	24.0 lbs	48.0 lbs
32 lb Bond	LTR	8.5" x 11"	1.6 lbs	8.0 lbs	16.0 lbs	32.0 lbs
32 lb Bond	Tabloid	11" x 17"	3.2 lbs	16.0 lbs	32.0 lbs	64.0 lbs
80 lb Cover	LTR	8.5" x 11"	2.8 lbs	13.7 lbs	27.6 lbs	54.9 lbs
80 lb Cover	Tabloid	11" x 17"	5.5 lbs	27.6 lbs	54.9 lbs	110.0 lbs
140 lb Index	LTR	8.5" x 11"	3.4 lbs	17.2 lbs	34.4 lbs	68.8 lbs
140 lb Index	Tabloid	11" x 17"	6.9 lbs	34.4 lbs	68.8 lbs	137.6 lbs
110 lb Cover	LTR	8.5" x 11"	4.1 lbs	9.4 lbs	18.8 lbs	37.6 lbs
110 lb Cover	Tabloid	11" x 17"	8.2 lbs	18.8 lbs	37.6 lbs	75.2 lbs

[13] The weight of stacks of 100, 500, 1,000 and 2,000 sheets - Examples for US media

Use the EasyLift

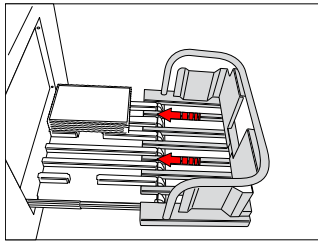
Step	Action	Illustration
1	Slide the forks of the EasyLift under the paper.	

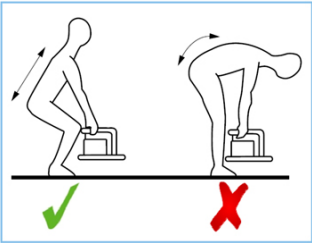
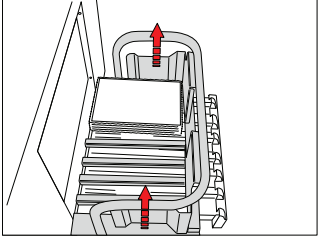
Step	Action	Illustration
2	<p>When lifting, make sure to bend your knees and keep your back straight.</p> <p> CAUTION Do not lift more than 15 kg (33 lb) to avoid physical injuries. Please observe the national health and safety regulations in your country.</p>	
3	<p>Lift the EasyLift to remove the paper from the eject tray. Make sure to place the EasyLift on a level surface.</p>	

Appendix A

Specifications

Specifications

Item	Specification
Paper size/weight/type	Paper size (Top tray, stack tray, eject tray): A3, B4, A4R, A4, B5R, B5, A5R LGL, LTR, LTRR, STMTR, SRA3, EXEC, EXECR 11" x 17", 12" x 18", 13" x 19" Custom sizes: 140 mm x 182 mm - 330.2 mm x 487.7 mm (5.5" x 7.2" - 13.0" x 19.2")
	Weight*: 50 g/m ² to 325 g/m ² (13 lb bond to 120 lb cover)
	Type: All media supported by printer
Tray capacity	Top tray: 200 sheets (80 g/m ² , 20 lb bond) (20 mm, 0.8" in height) Stack tray, eject tray: 3,000 sheets (80 g/m ² , 20 lb bond) or 355 mm (14.0") in height
Power source	90 V - 264 V, 47 Hz - 63 Hz, 10 A
Maximum power consumption	300 W maximum
Dimensions (H x W x D)	1,040 mm x 899 mm x 745 mm (40.9" x 35.4" x 29.3") 1,040 mm x 899 mm x 1,250 mm (40.9" x 35.4" x 49.2") (when eject tray is ejected)
Weight	120 kg (264.6 lb)

* Paper weight differs depending on the connected host machine.

Index

E

Eject a stack manually	
As soon as possible.....	16
At the next set boundary.....	16
Error sheet	
A1.....	30
Internal error tray.....	30

F

Filling level.....	22
Examples.....	23
Filling scenarios	
Filling level.....	18
Limit the stack height.....	18
Maximum filling.....	18
Next job, next tray.....	18

M

Main parts	
Eject tray.....	8
Front cover.....	8
Front door.....	8
Power switch.....	8
Power switch cover.....	8
Slide door.....	8
Stack tray.....	8
Stacker control panel.....	8
Top cover.....	8
Top tray.....	8
Maximum stack height.....	21
Examples.....	23
Minimum filling level	
Examples.....	23

O

Optionals	
EasyLift.....	42

P

Paper jam	
A2-A5.....	31
A6-A7.....	33
B1.....	35

B2-B5.....	37
C1.....	39
Flip wheel.....	39
Horizontal paper path.....	37
Input paper path.....	31
Input paper path of registration unit.....	33
Labels.....	28
Paper path.....	35

Power

Turn off.....	15
Turn on.....	14

S

Settings Editor	
Face orientation.....	19
Feed edge.....	19
Filling level.....	19
Header orientation.....	19
Maximum stack height.....	19
Offset stacking.....	19
Reverse order.....	19
Stacker.....	19
Stack height.....	21
Stacker control panel	
Eject button.....	10
LEDs.....	10
Status.....	10
Straightest stacks possible.....	19

T

Turn the stacker off.....	15
Turn the stacker on.....	14



CANON INC.

30-2, Shimomaruko 3-chome, Ohta-ku, Tokyo 146-8501, Japan

CANON U.S.A., INC.

One Canon Park, Melville, NY 11747, U.S.A.

CANON CANADA INC.

6390 Dixie Road Mississauga, Ontario L5T 1P7, Canada

CANON EUROPA N.V.

Bovenkerkerweg 59, 1185 XB Amstelveen, The Netherlands

(See <http://www.canon-europe.com/> for details on your regional dealer)

CANON LATIN AMERICA, INC.

703 Waterford Way Suite 400 Miami, Florida 33126 U.S.A.

CANON AUSTRALIA PTY. LTD

1 Thomas Holt Drive, North Ryde, Sydney, N.S.W. 2113, Australia

CANON CHINA CO., LTD

15F Jinbao Building No.89 Jinbao Street, Dongcheng District, Beijing 100005, China

CANON SINGAPORE PTE. LTD.

1 HarbourFront Avenue #04-01 Keppel Bay Tower, Singapore 098632

CANON HONGKONG CO., LTD

19/F., The Metropolis Tower, 10 Metropolis Drive, Hunghom, Kowloon, Hong Kong