

Canon

imageCLASS

D 680

Fax Guide



Please read this guide before operating this equipment.
After you finish reading this guide, store it in a safe place for future reference.

ENG

Using Your Documentation

Your machine includes the following documentation. This documentation has been designed so that you can easily use your machine to suit your particular needs.

Setting up the machine
Setting up paper
Installing the CAPT.....



Set-up Instructions

Document and paper handling
Making copies
Maintenance
Troubleshooting feed and copy issues



Reference Guide

Sending and receiving faxes
Speed dialing
Troubleshooting fax issues



Fax Guide
Only for the imageCLASS D680 model

Printing with the CAPT.....
Checking the status of a print job.....
Troubleshooting CAPT issues.....



Printer Guide



• Documentation is included on the CD-ROM in PDF form.

Copyright

Copyright ©2002 by Canon, Inc. All rights reserved. No part of this publication may be reproduced, transmitted, transcribed, stored in a retrieval system, or translated into any language or computer language in any form or by any means, electronic, mechanical, magnetic, optical, chemical, manual, or otherwise, without the prior written permission of Canon, Inc.

Trademarks

Canon is a registered trademark and UHQ™ is a trademark of Canon, Inc.



Super G3 is a phrase used to describe the new generation of fax machines that use ITU-T V.34 standard 33.6 Kbps* modems. Super G3 High Speed Fax machines allow transmission time of approximately 3 seconds* per page which results in reduced telephone line charges.

* Approximately 3 seconds per page fax transmission time based on ITU-T No. 1 Chart (Standard Mode) at 33.6 Kbps modem speed. The Public Switched Telephone Network (PSTN) currently supports 28.8 Kbps modem speeds or lower, depending on telephone line conditions.

Contents

Chapter 1: Introduction

Customer Support.....	1-1
Operation Panel.....	1-1
Standby Display.....	1-3
Making Connections.....	1-3
Connecting the Telephone Line and an External Device.....	1-3

Chapter 2: Registering Information

Methods of Registering Information in the Machine.....	2-1
Guidelines for Entering Numbers, Letters, and Symbols.....	2-1
Correcting a Mistake.....	2-2
Registering Required Sender Information.....	2-3
What is Sender Information?.....	2-3
Entering the Date and Time.....	2-4
Registering Your Fax/Telephone Number and Name.....	2-4
Printing a List to Check Information Registered in Your Machine.....	2-6
Setting the Telephone Line Type.....	2-7

Chapter 3: Speed Dialing

What is Speed Dialing?.....	3-1
Speed Dialing Methods.....	3-1
One-Touch Speed Dialing.....	3-2
Registering Numbers for One-Touch Speed Dialing.....	3-2
Changing/Deleting a One-Touch Speed Dialing Entry.....	3-3
Coded Speed Dialing.....	3-4
Registering Numbers for Coded Speed Dialing.....	3-4
Changing/Deleting a Coded Speed Dialing Entry.....	3-5
Group Dialing.....	3-7
Creating Groups.....	3-7

Speed Dialing Lists.....	3-9
Printing Speed Dialing Lists.....	3-9
Canceling the Print Out List.....	3-11
Registering a Password and Subaddress.....	3-12

Chapter 4: Sending Faxes

Preparing to Send a Fax.....	4-1
Documents You Can Fax.....	4-1
Adjusting the Quality of Your Faxes.....	4-1
Dialing Methods.....	4-2
Sending Methods.....	4-5
Memory Sending.....	4-5
Canceling Sending.....	4-7
Redialing When the Line is Busy.....	4-8
Manual Redialing.....	4-8
Automatic Redialing.....	4-8
Sequential Broadcasting.....	4-9
Delayed Sending.....	4-11
Confirming Transmission Status and Sending Reservation.....	4-12
Confirming Transmission Status.....	4-12
Confirming Sending Reservation.....	4-12
Documents Stored in Memory.....	4-13
Printing a List of Documents in Memory.....	4-13
Resending a Document in Memory.....	4-14
Printing a Document in Memory.....	4-15
Deleting a Document from Memory.....	4-16

Chapter 5: Receiving Faxes

Different Ways to Receive a Fax.....	5-1
Setting the Receive Mode.....	5-2
Setting the Options for FaxTel Mode.....	5-3
Setting the Options for Distinctive Ring Pattern Detection Feature: DRPD.....	5-5
Receiving Faxes Manually.....	5-6
Registering a Password and Subaddress for Polling.....	5-7
Receiving While Performing Other Tasks.....	5-9
Receiving Faxes in Memory When a Problem Occurs.....	5-9
Canceling Receiving.....	5-9

Chapter 6: Special Features

Special Dialing	6-1
Dialing Through a Switchboard	6-1
Dialing an Overseas Number (With Pauses)	6-1
Switching Temporarily to Tone Dialing.....	6-2

Chapter 7: Reports and Lists

Summary of Reports and Lists	7-1
ACTIVITY REPORT	7-2
TX (Transmission) REPORT.....	7-3
MULTI TX/RX (Transaction) REPORT	7-4
RX (Reception) REPORT	7-4

Chapter 8: Troubleshooting

LCD Messages	8-1
Faxing Problems.....	8-2
Sending Problems	8-2
Receiving Problems.....	8-3
Telephone Problems	8-5
If a Power Cut Occurs	8-5
If You Cannot Solve the Problem.....	8-6

Chapter 9: Setting the Additional Functions

Understanding the “Additional Functions”.....	9-1
Accessing the Additional Functions.....	9-1
Menu Descriptions	9-2

Appendix: Specifications

Facsimile	A-1
Telephone	A-1

Index	I-1
--------------------	-----

Users in the U.S.A.

■ Pre-Installation Requirements for Canon Facsimile Equipment

A. Location

Supply a suitable table, cabinet, or desk. See the Reference Guide for the machine's dimensions and weight.

B. Phone Line Requirements

1. Only a single line, touch-tone or rotary telephone set is to be used.
2. Order an RJ11-C modular jack (USOC code), which should be installed by the telephone company. If the RJ11-C jack is not present, installation cannot be done.
3. Order a normal business line from your telephone company's business representative. The line should be a regular voice grade line or the equivalent. Use one line per machine.

DDD (DIRECT DISTANCE DIAL) LINE

-or-

IDDD (INTERNATIONAL DIRECT DISTANCE DIAL) LINE IF YOU COMMUNICATE OVERSEAS



NOTE

- Canon recommends an individual line following industry standards, e.g., the 2500 (Touch Tone) or 500 (Rotary/Pulse Dial) telephones. A dedicated extension off a PBX unit without "Call Waiting" can be used with your unit. Key telephone systems are not recommended because they send non-standard signals to individual telephones for ringing and special codes, which may cause a fax error.

C. Power Requirements

This equipment should be connected to a standard 120-volt AC, three-wire grounded outlet only. Do not connect this machine to an outlet or power line shared with other appliances that cause "electrical noise." Air conditioners, electric typewriters, copiers, and machines of this sort generate electrical noise which often interferes with communications equipment and the sending and receiving of documents.

■ Connection of the Equipment

This equipment complies with Part 68 of the FCC rules and the requirements adopted by the ACTA. On the rear panel of this equipment is a label that contains, among other information, a product identifier in the format US:AZDFA03BF141412. If requested, this number must be provided to the telephone company.

This equipment may not be used on coin service provided by the telephone company. Connection to party lines is subjected to state tariffs.

An FCC compliant telephone cord and modular jack are provided with this equipment. This equipment is designed to be connected to the telephone network or premises wiring using a compatible modular jack which is Part 68 compliant. See Installation instructions for details.

The REN is used to determine the number of devices that may be connected to a telephone line. Excessive RENs on a telephone line may result in the devices not ringing in response to an incoming call. In most but not all areas, the sum of RENs should not exceed five (5.0). To be certain of the number of devices that may be connected to a line, as determined by the total RENs, contact the local telephone company. The REN for this product is part of the product identifier that has the format US:AZDFA03BF141412. The digits represented by 03 are the REN without a decimal point (e.g., 03 is a REN of 0.3).

■ In Case of Equipment Malfunction

Should any malfunction occur which cannot be corrected by the procedures described in this Fax Guide, disconnect the equipment from the telephone line and unplug the power cord. The telephone line should not be reconnected or the power cord plugged in until the problem is completely resolved. Users should contact Canon Authorized Service Facilities for servicing of equipment. Information regarding Authorized Service Facility locations can be obtained by calling the Canon USA Consumer Information Center. (1-800-828-4040)

■ Rights of the Telephone Company

Should the equipment cause harm to the telephone network, the telephone company may temporarily disconnect service. The telephone company also retains the right to make changes in facilities and services which may affect the operation of this equipment. When such changes are necessary, the telephone company is required to give adequate prior notice to the user.

■ FCC Notice

Facsimile Transceiver, Model F141412

This device complies with Part 15 of the FCC Rules.

Operation is subject to the following two conditions:

- (1) This device may not cause harmful interference, and
- (2) this device must accept interference received, including interference that may cause undesired operation.



NOTE

- This equipment has been tested and found to comply with the limits for a class B digital device, pursuant to Part 15 of the FCC Rules. These limits are designed to provide reasonable protection against harmful interference in a residential installation. This equipment generates, uses and can radiate radio frequency energy and, if not installed and used in accordance with the instructions, may cause harmful interference to radio communications. However, there is no guarantee that interference will not occur in a particular installation. If this equipment does cause harmful interference to radio or television reception, which can be determined by turning the equipment off and on, the user is encouraged to try to correct the interference by one or more of the following measures:
 - Reorient or relocate the receiving antenna.
 - Increase the separation between the equipment and receiver.
 - Connect the equipment into an outlet on a circuit different from that to which the receiver is connected.
 - Consult the dealer or an experienced radio/TV technician for help.

Use of shielded cable is required to comply with class B limits in Subpart B of Part 15 of FCC Rules.

Do not make any changes or modifications to the equipment unless otherwise specified in the Fax Guide. If such changes or modifications should be made, you could be required to stop operation of the equipment.

Canon U.S.A. Inc.
One Canon Plaza, Lake Success, NY 11042, U.S.A.
TEL No. (516) 328-5000

The Telephone Consumer Protection Act of 1991 makes it unlawful for any person to use a computer or other electronic device to send any message via a telephone fax machine unless such message clearly contains in a margin at the top or bottom of each transmitted page or on the first page of the transmission, the date and time it is sent and an identification of the business or other entity, or other individual sending the message and the telephone number of the sending machine or such business, other entity, or individual.

To automatically enter this information into your machine, follow the instructions in Chapter 2 of this guide.

Users in Canada

■ Pre-Installation Requirements for Canon Facsimile Equipment

A. Location

Supply a suitable table, cabinet, or desk. See the Reference Guide for the machine's dimensions and weight.

B. Phone Line Requirements

1. Provide only a single-line to touch-tone or rotary telephone set terminated with a standard 4-pin modular phone plug. (Touch-tone is recommended if available in your area.)
2. Order a CA11A modular jack (USOC code), which should be installed by the telephone company. If the CA11A jack is not present, installation cannot be done.
3. Order a normal business line from your telephone company's business representative. The line should be a regular voice grade line or equivalent. Use one line per machine.

DDD (DIRECT DISTANCE DIAL) LINE

-or-

IDDD (INTERNATIONAL DIRECT DISTANCE DIAL) LINE IF YOU COMMUNICATE OVERSEAS



NOTE

- Canon recommends an individual line following industry standards, e.g., the 2500 (Touch Tone) or 500 (Rotary/Pulse Dial) telephones. A dedicated extension off a PBX unit without "Camp On" signals is also permissible with your unit. Key telephone systems are not recommended because they send non-standard signals to individual telephones for ringing and special codes, which may cause a fax error.

C. Power Requirements

The power outlet should be a three-prong grounded receptacle (Single or Duplex). It should be independent from copiers, heaters, air conditioners or any electric equipment that is thermostatically controlled. The rated value is 120 volts and 15 amperes.

■ NOTICE

This equipment meets the applicable Industry Canada Terminal Equipment Technical Specifications. This is confirmed by the registration number. The abbreviation, IC, before the registration number signifies that registration was performed based on a Declaration of Conformity indicating that Industry Canada technical specifications were met. It does not imply that Industry Canada approved the equipment.

Cet appareil est conforme aux Spécifications techniques des équipements terminaux de l'Industrie du Canada.

Ceci est confirmé par le numéro d'enregistrement. L'abréviation IC précédant le numéro d'enregistrement signifie que l'enregistrement a été effectué sur la base de la Déclaration de conformité indiquant que le produit est conforme aux spécifications techniques du Canada. Ceci n'implique pas que le produit ait été approuvé par l'industrie du Canada.

Before installing this equipment, users should ensure that it is permissible to be connected to the facilities of the local telecommunications company. The equipment must also be installed using an acceptable method of connection. The customer should be aware that compliance with the above conditions may not prevent degradation of service in some situations.

Repairs to certified equipment should be coordinated by a representative designated by the supplier. Any repairs or alterations made by the user to this equipment, or equipment malfunctions, may give the telecommunications company cause to request the user to disconnect the equipment.

Users should ensure for their own protection that the electrical ground connections of the power utility, telephone lines and internal metallic water pipe system, if present, are connected together. This precaution may be particularly important in rural areas.



CAUTION

- **Users should not attempt to make such connections themselves, but should contact the appropriate electric inspection authority or electrician, as appropriate.**



IMPORTANT

- This Class B digital apparatus meets all requirements of the Canadian Interference-Causing Equipment Regulations.

Cet appareil numérique de la classe B respecte toutes les exigences du Règlement sur le matériel brouilleur du Canada.

The Ringer Equivalence Number (REN) for this terminal equipment is 0.3. The REN assigned to each terminal equipment provides an indication of the maximum number of terminals allowed to be connected to a telephone interface. The termination on an interface may consist of any combination of devices subject only to the requirement that the sum of the Ringer Equivalence Numbers of all the devices does not exceed five.

Le Nombre d'équivalence Ringer (REN) de cet appareil terminal est 0.3. Le REN attribué à chaque équipement terminal fournit une indication sur le nombre maximum de terminaux pouvant être connectés sur une interface téléphonique. La terminaison sur une interface peut consister en n'importe quelle combinaison d'appareils, à la condition seulement que la somme des Nombres d'équivalence Ringer de tous les appareils ne soit pas supérieure à 5.

CANON CANADA INC.
1-800-OK-CANON (1-800-652-2666)
24 HOURS A DAY, SEVEN DAYS A WEEK

Type Conventions Used in This Guide

Please read the following list of symbols, terms, and abbreviations used in this guide.



• Indicates a warning concerning operations that may lead to death or injury to persons if not performed correctly. In order to use the machine safely, always pay attention to these warnings.



• Indicates a caution concerning operations that may lead to injury to persons or damage to property if not performed correctly. In order to use the machine safely, always pay attention to these cautions.



• Indicates an operational warning or restriction. Be certain to read these items to operate the machine correctly, and to avoid damage to the machine.



• Indicates a note for operation or an additional explanation. Reading these is highly recommended.

(→ p. n-nn)	A number preceded by an arrow and enclosed in parenthesis refers to a page in this guide where more information on the topic of the previous sentence can be found.
→ Set-up Instructions	Refer to the Set-up Instructions for details on the topic of the previous sentence.
→ Reference Guide	Refer to the Reference Guide for details on the topic of the previous sentence.
machine	The word “machine” refers to the imageCLASS D680.
default	A setting that remains in effect unless you change it.
document or fax	The original sheet(s) of paper you send or receive with the machine.
menu	A list of settings from which you select an item to set up or change. A menu has a title which appears in the LCD.
transaction number	When you send or receive a document, your machine automatically assigns the document a unique transaction number. A transaction number is a four-digit number that will help you keep track of documents you send and receive.
TX/RX NO.	TX/RX NO. is the abbreviation used for <i>Transaction number</i> .
TX	Denotes <i>Sending</i> .
RX	Denotes <i>Receiving</i> .

In addition, this guide uses distinctive typefaces to identify keys and information in the LCD:

- The keys you press appear in this typeface: **Stop/Reset**.
- Information in the LCD appears in this typeface: FAX SETTINGS.

Chapter 1

Introduction

Customer Support

Your machine is designed with the latest technology to provide trouble-free operation. If you encounter a problem with the machine's operation, try to solve it by using the information in Chapter 8. If you cannot solve the problem or if you think your machine needs servicing, contact your service representative, → Reference Guide.

Operation Panel

This section describes keys used when sending and receiving faxes.

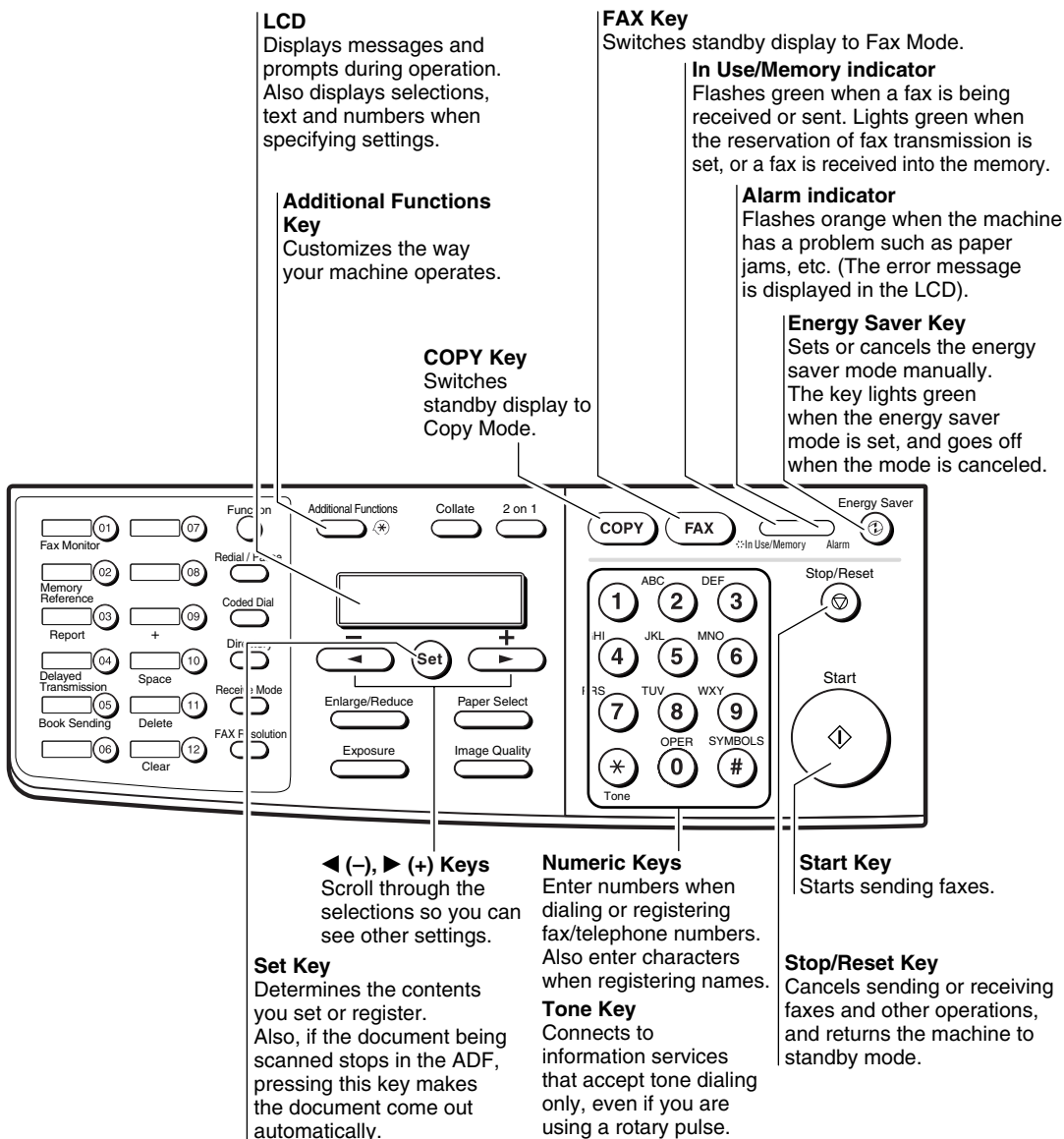

One-Touch Speed Dialing Keys

The keys marked 01 to 12 can be used to dial fax/telephone numbers pre-registered. To dial using these keys, you need to register the number for one-touch speed dialing. When the Function key is pressed and the indicator lights green, the following keys can be used for the fax functions. Also, if fax functions are programmed into these keys, they can be used directly as One-Touch Keys without pressing Function to execute the fax functions.

Fax Monitor Key

Confirms the status of fax communication.

Memory Reference Key

Confirms documents stored in the machine for memory sending or memory receiving.

Report Key

Prints a report listing fax communications, dial list, data list or document list. You can also use this key to cancel the printing job.

Delayed Transmission Key

Specifies the fax sending time for the delayed sending function.

Book Sending Key

This key can be used to send documents from the platen glass.

+ Key

Enters a plus sign (+).

Space Key

Enters a space between letters and numbers.

Delete Key

Deletes characters one by one.

Clear Key

Deletes all characters.

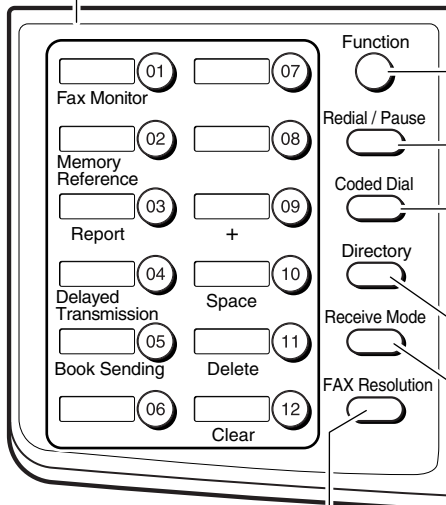

Function Key

After pressing this key, you can use the keys marked 01 to 12 (except for 06 to 08) for the fax functions. Lights green when the key is pressed and goes off when the key is pressed again.

Redial/ Pause Key

Dials the last number dialed with the numeric keys, or inserts a pause within and/or after a number.

Coded Dial

Coded Dial Key

The key can be used to dial fax/telephone numbers pre-registered under a two-digit code. To dial by using this key, you need to register a number for the coded speed dialing.

Directory

Directory Key

Searches fax/telephone numbers pre-registered under the One-Touch Speed Dialing Keys or Coded Speed Dialing Keys using the names of the registers.

Receive Mode

Receive Mode Key

Selects the receive mode.

FAX Resolution

FAX Resolution Key

Selects the fax resolution: STANDARD, FINE, PHOTO, SUPER FINE or ULTRA FINE.

Standby Display

The standby display differs depending on which mode is selected. When the machine is plugged in, the Copy Mode standby display appears. You can switch from Copy Mode to Fax Mode by pressing **FAX**. The standby display in Fax Mode is as follows:

■ Fax Mode

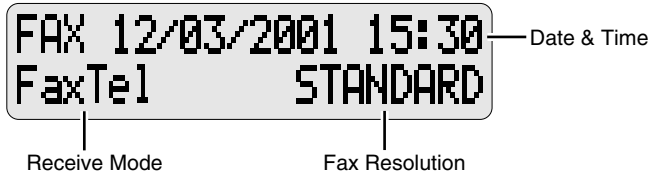

• The standby display in Copy Mode is, → Reference Guide.

Making Connections

■ Connecting the Telephone Line and an External Device

The machine has two jacks on the left side for connection of the following:



: Telephone line



: External device, such as telephone or answering machine

- 1 Connect the supplied telephone line to the  jack, then connect the other end of the line to the telephone jack on your wall.

- 2 If you need to send and receive faxes and voice calls, connect the line from the telephone or answering machine to the  jack.

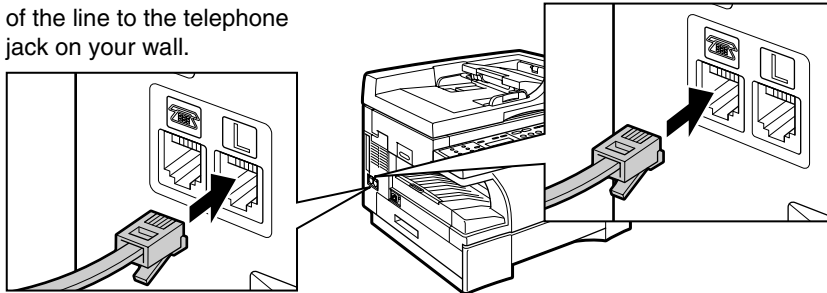

External Device Connections

The external device which you connect to the machine depends on how you want to use the machine. Recommended device connections and receive modes are shown below.



IMPORTANT

- If you have connected an external device to the machine, be sure to select the correct receive mode. (→ p. 5-1)

Recommended Device Connections ————— Receive Modes

Machine and Telephone ————— FaxTel
 Machine Only ————— DRPD
 Machine Only ————— Manual

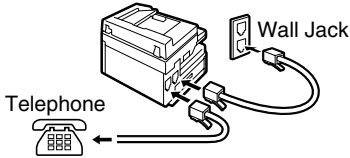

Machine Only ————— FaxOnly

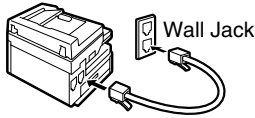

Machine and Answering Machine ————— AnsMode

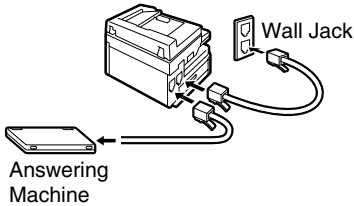

Machine, Answering Machine and Telephone ————— AnsMode

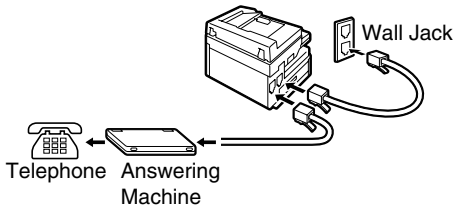

Chapter 2

Registering Information

Methods of Registering Information in the Machine

To customize the machine to your particular needs, you can adjust the general operation, sending, receiving, printing, system settings, and speed dialing settings.

You can adjust settings directly via the operation panel of the machine. Detailed instructions are described in this guide.

Guidelines for Entering Numbers, Letters, and Symbols

When you come to a step that requires you to enter a name or number, refer to the table below to determine which numeric key to press for the character you want:

Key	Letters (:A)	Numbers (:1)
①	@ . - _ /	1
<small>ABC</small> ②	ABCabc	2
<small>DEF</small> ③	DEFdef	3
<small>GHI</small> ④	GHIghi	4
<small>JKL</small> ⑤	JKLjkl	5
<small>MNO</small> ⑥	MNOmno	6
<small>PRS</small> ⑦	PRSprs	7
<small>TUV</small> ⑧	TUVtuv	8
<small>WXY</small> ⑨	WXYZwxyz	9
<small>OPER</small> ⑩		0
<small>SYMBOLS</small> #	- . * # ! " , ; : ^ ` _ = / ' ? \$ @ % & + \ → () [] { } < >	
<small>Tone</small> *	Letter input (:A) ↔ Number input (:1)	



NOTE

- If you do not press any key for more than 2 minutes, when you enter data, the machine will automatically return to standby mode with the auto clear function.
- AUTO CLEAR can be set within a range of 1 to 9 minutes at one minute intervals. You can also disable the auto clear function, → Reference Guide.



• The **Function** key will light up by pressing **Function** to be able to operate **Space**, **Delete** or **Clear**.

■ Entering Letters

1 Press **✳** to switch to letter mode (: A).

Ex:

2 Press the numeric key that contains the letter you want.

Ex:

- Press repeatedly until the letter you want appears. Each key cycles through the letters it contains.
- If you are unsure which key to press for the letter you want, → p. 2-1.



3 Continue entering other letters using the numeric keys.

Ex:

- If the next letter you want to enter is under a different numeric key, simply press that key until the letter you want appears.
- or-
- If the next letter you want to enter is under the same numeric key you pressed in step 2, use **▶ (+)** to move the cursor to the right. Then press that same numeric key repeatedly until the letter you want appears.
- Press **Space** to enter a space and move the cursor to the right.

■ Entering Symbols

1 Press **✳** to switch to letter mode (: A).

Ex:

2 Press **#** repeatedly until the symbol you want appears.

Ex:



3 If you want to enter another symbol, use **▶ (+)** to move the cursor to the right, then press **#** repeatedly until the symbol you want appears.

Ex:

■ Entering Numbers

1 Press **✳** to switch to number mode (: 1).

Ex:

2 Press the numeric key that contains the number you want.

Ex:

- Press **Space** to enter a space and move the cursor to the next digit.



3 Continue entering other numbers using the numeric keys.

Ex:

■ Correcting a Mistake

If you make a mistake while entering letters or numbers, you can delete it by pressing **Delete** or **Clear**.

■ To delete the last letter/number

Press **Delete** once to delete the last letter or the last number you entered.

■ To delete all letters/numbers

Press **Clear** to delete all letters or all numbers you entered.

Registering Required Sender Information

In the United States, FCC rules governing the use of facsimile equipment state that the following sender information must be printed on every facsimile transmission:

- Your fax/telephone number
- Your personal name or company name
- The date and time of transmission

Your machine has been designed to print this information at the top of every fax you send. You must therefore register your machine's fax/telephone number, your personal name or company name, and the current date and time before using your machine.

This section gives details on registering the sender information.

What is Sender Information?

When you receive a fax, the name of the person or company who sent you the fax, their fax/telephone number, and the date and time of transmission will be printed in small type at the top of each page. This information is called the *Sender information* or the *Transmit Terminal Identification (TTI)*. Similarly, you must register your details in your machine so that whenever you send a fax, the other party knows who sent it, and when it was sent. Below is an example of how your sender information would be printed on a fax sent from your machine:

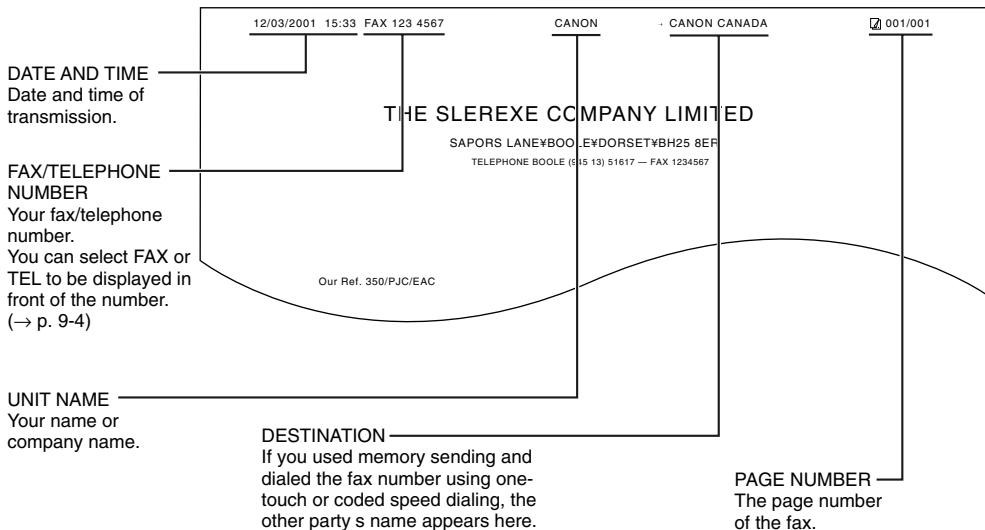

NOTE

- You can set the sender information to print inside or outside the image area. (→ p. 9-4)
- You can enter the sender information from the Additional Functions. (→ p. 9-4)

■ Entering the Date and Time

1 Press **Additional Functions**.

2 Use ◀ (-) or ▶ (+) to select 5 .TIMER SETTINGS.

```
ADDITIONAL FUNCTIONS
5.TIMER SETTINGS
```

3 Press **Set** twice.

The date and time currently set for the machine are displayed.

```
TIMER SETTINGS
1.DATE/TIME SETTING
```

Ex:

```
DATE/TIME SETTING
12/03/01 12:10
```



4 Use the numeric keys to enter the correct month, day, year, and time in this order.

Ex:

```
DATE/TIME SETTING
12/03/01 15:30
```

- Use ◀ (-) or ▶ (+) to move the cursor under the number you want to change, then press the numeric key.
- Enter only the last two digits of the year.
- Use the 24-hour format for the time setting (e.g.1:00 p.m. as 13:00).

5 Press **Set**.

```
DATE/TIME SETTING
DATA ENTRY OK
```

```
TIMER SETTINGS
2.AUTO CLEAR
```

6 Press **Stop/Reset** to return to standby display.

■ Registering Your Fax/Telephone Number and Name



NOTE

- The **Function** key will light up by pressing **Function** to be able to operate the **Space, Delete, Clear** or + key.

1 Press **Additional Functions**.

2 Use ◀ (-) or ▶ (+) to select 3 .FAX SETTINGS.

```
ADDITIONAL FUNCTIONS
3.FAX SETTINGS
```

3 Press **Set** four times.

```
FAX SETTINGS
1.USER SETTINGS
```

```
USER SETTINGS
1.TEL LINE SETTINGS
```

```
TEL LINE SETTINGS
1.USER TEL NO.
```

Ex:

```
USER TEL NO.
TEL=
```



4 Use the numeric keys to enter your fax number (max. 20 digits, including spaces).

Ex:

```
USER TEL NO.
TEL= 123 4567
```

- If you have already registered your fax/telephone number, previous entry will be displayed. To change your fax/telephone number, use the numeric keys to enter your fax number.
- Press **Space** to enter a space.
- To enter a plus sign (+) before the number, press + key.
- If you make a mistake, press **Delete** or ◀ (-) to delete the last number or press **Clear** to delete all the numbers you entered.



5 Press **Set**.

```
USER TEL NO.  
DATA ENTRY OK
```

```
TEL LINE SETTINGS  
2.TEL LINE TYPE
```

6 Press **Additional Functions**.

```
USER SETTINGS  
1.TEL LINE SETTINGS
```

7 Use **◀ (-)** or **▶ (+)** to select 2 .UNIT NAME.

```
USER SETTINGS  
2 .UNIT NAME
```

8 Press **Set**.

Ex: : A



9 Use the numeric keys to enter your name or company name (max. 24 characters, including spaces).

Ex: : A

- If you are unsure how to enter characters, → p. 2-1.
- If you have already registered your name or company name, previous entry will be displayed. To change your name, press **Clear** to delete the previous entry and re-enter.
- Press **Space** to enter a space and move the cursor to the right.
- If you make a mistake, press **◀ (-)** or **▶ (+)** to move the cursor to the incorrect character, then press **Delete**. Or press **Clear** to delete all characters you entered.

10 Press **Set**.

Ex: : A

```
USER SETTINGS  
3 .TX TERMINAL ID
```

11 Press **Stop/Reset** to return to standby display.

■ Printing a List to Check Information Registered in Your Machine

You can print the USER'S DATA LIST to check the sender information and current settings of your machine.

1 Press **Additional Functions**.

2 Use **◀ (-)** or **▶ (+)** to select **7 . PRINT LISTS**.

```
ADDITIONAL FUNCTIONS
7 . PRINT LISTS
```



3 Press **Set** twice.

```
PRINT LISTS
1 . USER DATA
```

- The machine returns to standby mode then prints the USER'S DATA LIST.

The sender information is shown at the beginning of the list. The current settings of the machine are listed after this.

```
12/03/2001 16:40 FAX 123 4567          CANON          ☑ 001
*****
***  USER'S DATA LIST  ***
*****

1. COMMON SETTINGS
  DEFAULT SETTINGS          COPY
  SW AFTER AUTO CLR        DEFAULT MODE
  VOLUME CONTROL
    KEYPAD VOLUME          ON      1
    VOLUME                  ON      1
  ALARM VOLUME             ERROR ONLY
  VOLUME
  TX DONE TONE
  VOLUME
```

Setting the Telephone Line Type

Before using your machine, you need to make sure it is set for your telephone line type. If you are unsure of your telephone line type, check with your local telephone company. Your machine is factory-set to operate with a tone line (TOUCH TONE). If you need to change the setting, follow this procedure.

1 Press **Additional Functions**.

2 Use **◀ (-)** or **▶ (+)** to select **3 . FAX SETTINGS**.

```
ADDITIONAL FUNCTIONS
3 . FAX SETTINGS
```

3 Press **Set** three times.

```
FAX SETTINGS
1 . USER SETTINGS
```

```
USER SETTINGS
1 . TEL LINE SETTINGS
```

```
TEL LINE SETTINGS
1 . USER TEL NO.
```

4 Use **◀ (-)** or **▶ (+)** to select **2 . TEL LINE TYPE**.

```
TEL LINE SETTINGS
2 . TEL LINE TYPE
```



5 Press **Set**.

```
TEL LINE TYPE
TOUCH TONE
```

Ex:

6 Use **◀ (-)** or **▶ (+)** to select the telephone line type setting you want to set.

```
TEL LINE TYPE
ROTARY PULSE
```

Ex:

- You can select from the following:
 - ROTARY PULSE
 - TOUCH TONE

7 Press **Set**.

```
TEL LINE SETTINGS
3 . TX START SPEED
```

8 Press **Stop/Reset** to return to standby display.

Chapter 3

Speed Dialing

What is Speed Dialing?

Speed dialing allows you to simplify dialing procedures by registering a fax/telephone number(s) and name under a one-touch speed dialing key or coded speed dialing keys. You can then dial that number by pressing only one or a few keys.

Speed Dialing Methods

There are three speed dialing methods available with your machine as follows:

■ One-Touch Speed Dialing (→ p. 3-2)

Allows you to dial a fax or telephone number by pressing only one key. You can register up to 12 destinations for one-touch speed dialing.

■ Coded Speed Dialing (→ p. 3-4)

Allows you to dial a fax or telephone number by pressing **Coded Dial** followed by a two-digit code of your choice. You can register up to 100 different destinations.

■ Group Dialing (→ p. 3-7)

Allows you to dial a group of registered one-touch and/or coded speed dialing fax numbers. By registering a group for one-touch or coded speed dialing, you press only one or a few keys to send the same document to several destinations.

The following pages describe how to register numbers for speed dialing.



NOTE

- For instructions on dialing using the speed dialing methods, → pp. 4-3, 4-4.

One-Touch Speed Dialing



- The **Function** key will light up by pressing **Function** to be able to operate **Space**, **Delete** or **Clear**.

■ Registering Numbers for One-Touch Speed Dialing

1 Press **Additional Functions**.

2 Use ◀ (-) or ▶ (+) to select 4 .ADD . REGISTRATION.

```
ADDITIONAL FUNCTIONS
4 .ADD . REGISTRATION
```

3 Press **Set** twice.

```
ADD . REGISTRATION
1 .1 -TOUCH SPD DIAL
```

Ex: 1 -TOUCH SPD DIAL
01= 905 795 1111

4 Use ◀ (-) or ▶ (+) to select a one-touch speed dialing key (01 to 12).

Ex: 1 -TOUCH SPD DIAL
04=

- You can directly select the one-touch speed dialing key by pressing it.
- If a one-touch speed dialing key has already been registered, the number registered under that key appears.
- If a group is already registered under a one-touch speed dialing key, GROUP DIAL appears.
- If the fax functions have been programmed into the keys marked 01 to 12 using PROG 1-TOUCH KEY in the Additional Functions, PROG 1-TOUCH KEY will appear.

5 Press **Set** twice.

```
1 -TOUCH SPD DIAL
1 .TEL NUMBER ENTRY
```

```
TEL NUMBER ENTRY
TEL=
```

6 Use the numeric keys to enter the fax/telephone number you want to register (max. 120 digits, including spaces and pauses).

Ex: TEL NUMBER ENTRY
TEL=2 50921_

- Press **Space** to enter a space and move the cursor to the next digit. Spaces are optional and are ignored during dialing.

7 Press **Redial/Pause** to enter a pause (→ p. 6-1).

- If you make a mistake, move the cursor to the incorrect number by pressing ◀ (-) or ▶ (+), and press **Delete** repeatedly to delete the numbers one by one. Or, press **Clear** to delete all the numbers you have entered.

7 Press **Set** twice.

```
TEL NUMBER ENTRY
DATA ENTRY OK
```

```
1 -TOUCH SPD DIAL
2 .NAME
```

```
: A
```

8 Use the numeric keys to enter the name that goes with the number (max. 16 characters, including spaces).

Ex: Canon ITALIA : A

- If you are unsure how to enter characters, → p. 2-1.

9 Press **Set**.

```
: A
DATA ENTRY OK
```

```
1 -TOUCH SPD DIAL
3 .OPTIONAL SETTING
```

- For details of OPTIONAL SETTING, refer to the following items as required.
 - Registering a Password and Subaddress (→ p. 3-12)
 - Registering a Password and Subaddress for Polling (→ p. 5-7)
 - TX TIME SETTING in the Additional Functions (→ p. 9-9)

10 To continue registering other one-touch speed dialing keys, press **Additional Functions** then repeat the procedure from step 4.

– or –

Press **Stop/Reset** to return to standby display.



- Use the destination label provided on your machine for easy reference dialing.

■ Changing/Deleting a One-Touch Speed Dialing Entry



• The **Function** key will light up by pressing **Function** to be able to operate **Space**, **Delete** or **Clear**.

1 Follow steps 1 to 3 of “Registering Numbers for One-Touch Speed Dialing.” (→ p. 3-2)

2 Use ◀ (-) or ▶ (+) to select the one-touch speed dialing key assigned to the entry you want to change or delete.

Ex:

1-TOUCH SPD DIAL
06= 1 432 2015

- You can directly select the one-touch speed dialing key by pressing it.

3 Press **Set** twice.

1-TOUCH SPD DIAL
1.TEL NUMBER ENTRY

TEL NUMBER ENTRY
TEL=1 432 2015_

■ To Change a One-Touch Speed Dialing Entry:

4 Press **Function**, then **Clear** to delete the previous entry, then re-enter the fax/telephone number.

Ex:

TEL NUMBER ENTRY
TEL=1 432 2060_

- If you do not want to change the fax/telephone number, ignore this step.
- Press **Space** to enter a space and move the cursor to the next digit. Spaces are optional and are ignored during dialing.
- Press **Redial/Pause** to enter a pause.
- If you make a mistake, move the cursor to the incorrect number by pressing ◀ (-) or ▶ (+), and press **Delete** repeatedly to delete the numbers one by one. Or, press **Clear** to delete all the numbers you have entered.

5 Press **Set** twice.

TEL NUMBER ENTRY
DATA ENTRY OK

1-TOUCH SPD DIAL
2.NAME

Ex:

Canon OPTIX_
:A

6 Press **Clear** to delete the previous entry, then re-enter the name.

Ex:

Canon OPTICS
:A

- If you do not want to change the name, ignore this step. Proceed to step 7.
- If you are unsure how to enter characters, → p. 2-1.

7 Press **Set**.

DATA ENTRY OK
:A

1-TOUCH SPD DIAL
3.OPTIONAL SETTING

8 Press **Stop/Reset** to return to standby display.

■ To Delete a One-Touch Speed Dialing Entry:

4 Press **Function**, then **Clear** to delete the fax/telephone number.

TEL NUMBER ENTRY
TEL=



- If you delete the number by mistake, press **Stop/Reset** before you press **Set**, so that the number is not deleted.

5 Press **Set**.

TEL NUMBER ENTRY
ERASING END

1-TOUCH SPD DIAL
2.NAME

6 Press **Stop/Reset** to return to standby display.

- The registered name is automatically cleared when you clear the fax/telephone number.

Coded Speed Dialing

■ Registering Numbers for Coded Speed Dialing



- The **Function** key will light up by pressing **Function** to be able to operate **Space**, **Delete** or **Clear**.

NOTE

1 Press **Additional Functions**.

2 Use ◀ (-) or ▶ (+) to select 4 .ADD . REGISTRATION.

```
ADDITIONAL FUNCTIONS
4 .ADD . REGISTRATION
```

3 Press **Set**.

```
ADD . REGISTRATION
1.1-TOUCH SPD DIAL
```

4 Use ◀ (-) or ▶ (+) to select 2 . CODED SPD DIAL.

```
ADD . REGISTRATION
2 .CODED SPD DIAL
```

5 Press **Set**.

Ex:

```
CODED SPD DIAL
*00=          2131 1250
```

6 Use ◀ (-) or ▶ (+) to select a coded speed dialing code (00 to 99).

Ex:

```
CODED SPD DIAL
*02=
```

- You can enter the coded speed dialing code (2-digit) with the numeric keys after pressing **Coded Dial**.
- If a coded speed dialing code has already been registered, the number registered under that code appears.
- If a group is already registered under a coded speed dialing code, GROUP DIAL appears.

7 Press **Set** twice.

```
CODED SPD DIAL
1 .TEL NUMBER ENTRY
```

```
TEL NUMBER ENTRY
TEL=_
```



8 Use the numeric keys to enter the fax/ telephone number you want to register (max. 120 digits, including spaces and pauses).

Ex:

```
TEL NUMBER ENTRY
TEL=1 49 39 25 25_
```

- Press **Space** to enter a space and move the cursor to the next digit. Spaces are optional and are ignored during dialing.
- Press **Redial/Pause** to enter a pause.
- If you make a mistake, move the cursor to the incorrect number by pressing ◀ (-) or ▶ (+), and press **Delete** repeatedly to delete the numbers one by one. Or, press **Clear** to delete all the numbers you have entered.

9 Press **Set** twice.

```
TEL NUMBER ENTRY
DATA ENTRY OK
```

```
CODED SPD DIAL
2 . NAME
```

```
_:A
```

10 Use the numeric keys to enter the name that goes with the number (max. 16 characters, including spaces).

Ex:

```
_:A
Canon FRANCE
```

- If you are unsure how to enter characters, → p. 2-1.



11 Press **Set**.

Ex: DATA ENTRY OK : A

CODED SPD DIAL
3 . OPTIONAL SETTING

- For details of **OPTIONAL SETTING**, refer to the following items as required.
 - Registering a Password and Subaddress (→ p. 3-12)
 - Registering a Password and Subaddress for Polling (→ p. 5-7)
 - **TX TIME SETTING** in the Additional Functions (→ p. 9-9)



- 12 To continue registering other coded speed dialing codes, press **Additional Functions** then repeat the procedure from step 6.
– or –
Press **Stop/Reset** to return to standby display.



NOTE

- You can print the **CODED DIAL LIST** showing all the numbers and names registered for coded speed dialing (→ pp. 3-9, 3-10). Keep this list near your machine for easy reference when dialing.

■ Changing/Deleting a Coded Speed Dialing Entry



NOTE

- The **Function** key will light up by pressing **Function** to be able to operate **Space**, **Delete** or **Clear**.

- 1 Follow steps 1 to 5 of “Registering Numbers for Coded Speed Dialing.” (→ p. 3-4)

- 2 Use **◀ (-)** or **▶ (+)** to select the coded speed dialing code assigned to the entry you want to change or delete.

Ex: CODED SPD DIAL
*32= 81 773 3115

- You can enter the coded speed dialing code (2-digit) with the numeric keys after pressing **Coded Dial**.

- 3 Press **Set** twice.

CODED SPD DIAL
1 . TEL NUMBER ENTRY

TEL NUMBER ENTRY
TEL=81 773 3115_



■ To Change a Coded Speed Dialing Entry:

- 4 Press **Function**, then **Clear** to delete the previous entry, then re-enter the fax/telephone number.

Ex: TEL NUMBER ENTRY
TEL=81 773 3173_

- If you do not want to change the fax/telephone number, ignore this step.
- Use **Space** to enter a space and move the cursor to the next digit. Spaces are optional and are ignored during dialing.
- Press **Redial/Pause** to enter a pause.
- If you make a mistake, move the cursor to the incorrect number by pressing **◀ (-)** or **▶ (+)**, and press **Delete** repeatedly to delete the numbers one by one. Or, press **Clear** to delete all the numbers you have entered.

- 5 Press **Set** twice.

TEL NUMBER ENTRY
DATA ENTRY OK

CODED SPD DIAL
2 . NAME

Ex: Canon UC_ : A



6 Press **Function**, then **Clear** to delete the previous entry, then re-enter the name.

Ex:

Canon UK	: A
----------	-----

- If you do not want to change the name, ignore this step.
- If you are unsure how to enter characters, → p. 2-1.

7 Press **Set**.

DATA ENTRY OK	: A
---------------	-----

CODED SPD DIAL 3.OPTIONAL SETTING

8 Press **Stop/Reset** to return to standby display.



■ To Delete a Coded Speed Dialing Entry:

4 Press **Function**, then **Clear** to delete the fax/telephone number.

TEL NUMBER ENTRY TEL=

5 Press **Set**.

TEL NUMBER ENTRY ERASING END

CODED SPD DIAL 2.NAME

6 Press **Stop/Reset** to return to standby display.

- The registered name is automatically cleared when you clear the fax/telephone number.

Group Dialing

Creating Groups



- The **Function** key will light up by pressing **Function** to be able to operate **Clear**.

NOTE

1 Press **Additional Functions**.

2 Use ◀ (-) or ▶ (+) to select 4 .ADD . REGISTRATION.

```
ADDITIONAL FUNCTIONS
4 .ADD . REGISTRATION
```

3 Press **Set**.

```
ADD . REGISTRATION
1 .1 -TOUCH SPD DIAL
```

4 Use ◀ (-) or ▶ (+) to select 3 .GROUP DIAL.

```
ADD . REGISTRATION
3 .GROUP DIAL
```

5 Press **Set**.

Ex:

```
GROUP DIAL
01=1 -TOUCH SPD DIAL
```

6 Select a one-touch speed dialing key or coded speed dialing code under which you want to register the group.



NOTE

- If you wish to register a group under the already registered one-touch speed dialing key or coded speed dialing code, or you want to re-enter a group, you must delete the previous information first. (→ pp. 3-3, 3-5, 3-6)
- Do not register a group under a one-touch speed dialing key or coded speed dialing code, in which SUBADDRESS TX or POLLING RX has been set. If you do so, you cannot send faxes to the other party's which have a subaddress registered.



■ **To register a group under a one-touch speed dialing key:**

Use ◀ (-) or ▶ (+) to select the key under which you want to register the group (01 to 12).

Ex:

```
GROUP DIAL
03 =
```

- If a one-touch speed dialing key has already been registered, 1-TOUCH SPD DIAL or GROUP DIAL appears.
- If the fax functions have been programmed into the keys marked 01 to 12 using PROG 1-TOUCH KEY in the Additional Functions, PROG 1-TOUCH KEY will appear.

■ **To register a group under a coded speed dialing code:**

Press **Coded Dial**, then use the numeric keys to enter the code under which you want to register the group (00 to 99).

Ex:

```
GROUP DIAL
*21 =
```

- If a coded speed dialing code has already been registered, CODED SPD DIAL or GROUP DIAL appears.

7 Press **Set** twice.

```
GROUP DIAL
1 .TEL NUMBER ENTRY
```

```
TEL =
```



8 Enter the one-touch and/or coded speed dialing numbers you want to register in the group.

- You cannot register numbers in groups that have not been registered for speed dialing.
- You can review the numbers registered under the group by pressing ◀ (-) or ▶ (+).

If you want to delete one of these numbers from the group:

Press ◀ (-) or ▶ (+) to display the number you want to delete and press **Clear** (ERASING END is displayed).

If you want to delete all numbers in the group:

Press ◀ (-) or ▶ (+) to display the number and press **Clear** repeatedly until all numbers are deleted.

Deleting all numbers will cancel the group.

- * If the group has already been registered, or the transmission time has already been registered using TX TIME SETTING, the group's name or the transmission time will not be deleted even if you delete all the numbers.
- You can cancel registering numbers and return to standby display by pressing the **Stop/Reset** anytime before pressing **Set** in step 9.

■ To enter a destination registered for one-touch speed dialing:

Press the one-touch speed dialing key assigned to each number you want to register in the group. Repeat for other keys.

Ex:

TEL=	2	50921
04	Canon	ITALIA

■ To enter a destination registered for coded speed dialing:

Press **Coded Dial**, then use the numeric keys to enter the two-digit code assigned to the number you want to register in the group. Repeat for other codes.

Ex:

TEL=	1	49	39	25	25
*02	Canon	FRANCE			

9 Press **Set** twice.

GROUP DIAL
2 . NAME
_____ : A

10 Use the numeric keys to enter a name for the group (max.16 characters, including spaces).

Ex:

Canon GROUP 2_	: 1
----------------	-----

- If you do not want to register the name, ignore this step.
- If you are unsure how to enter characters, → p. 2-1.

11 Press **Set**.

DATA ENTRY OK	: 1
GROUP DIAL	
3 . TX TIME SETTING	

- You can specify up to 5 different time settings for transmission time. (→ p. 9-9)

12 To continue registering other groups, press **Additional Functions** then repeat the procedure from step 6.

– or –
Press **Stop/Reset** to return to standby display.



NOTE

- You can print the GROUP DIAL LIST showing all the numbers and names registered for group dialing (→ pp. 3-9, 3-11). Keep this list near your machine for easy reference when dialing.

Speed Dialing Lists

You can print lists of fax/telephone numbers registered for speed dialing. Keep these lists near your machine so you can refer to them when dialing.

■ Printing Speed Dialing Lists

- 1 Press **Additional Functions**.
- 2 Use ◀ (-) or ▶ (+) to select 7 . PRINT LISTS.

ADDITIONAL FUNCTIONS
 7.PRINT LISTS
- 3 Press **Set**.

PRINT LISTS
 1.USER DATA
- 4 Use ◀ (-) or ▶ (+) to select 2 . SPEED DIAL LIST.

PRINT LISTS
 2.SPEED DIAL LIST
- 5 Press **Set**.

SPEED DIAL LIST
 1.1-TOUCH LIST
- 6 Use ◀ (-) or ▶ (+) to select the list you want to print.

SPEED DIAL LIST
 Ex: 2.CODED DIAL LIST

 - You can select from the following:
 - 1-TOUCH LIST

- CODED DIAL LIST
- 1-TOUCH (DETAIL)
- CODED (DETAIL)
- GROUP DIAL LIST

7 Press **Set**.

1-TOUCH LIST
 1.NO SORT

- If you selected 1-TOUCH LIST, or 1-TOUCH (DETAIL), CODED DIAL LIST or CODED (DETAIL) above, select SORT or NO SORT depending on what order you want the destinations to be printed:
 Select 1.NO SORT to print the list in key number order.
 -or-
 Select 2.SORT to print the list with the names of the destinations in alphabetical order.

8 Press **Set**.

- The machine prints the list and returns to standby mode.



- You can also print the list using **Report**. Press **Fax**, then press **Function** (the **Function** key lights up). Press **Report**, and select a report you want, then press **Set**. This procedure must be performed in Fax Mode.

Samples of the lists are shown as follows.

■ 1-TOUCH LIST

12/03/2001 17:02 FAX 123 4567		CANON		001
12/03/2001 17:03 FAX 123 4567		CANON		001
***** *** ONE-TOUCH SPEED DIAL TEL # LIST 1 *** *****				
NO.	DESTINATION TEL #	DESTINATION ID	TX TYPE	
[01]	905 7			
[03]	GROL			
[04]	2 509			
[06]	1 432			
[12]	2 887			
[12]	2 887 0166	Canon AUSTRALIA	REGULAR TX	
[01]	905 795 1111	Canon CANADA	REGULAR TX	
[03]	GROUP DIAL	Canon GROUP 2		
[04]	2 50921	Canon ITALIA	REGULAR TX	
[06]	1 432 2060	Canon OPTICS	REGULAR TX	

UNSORTED LIST: DESTINATIONS LISTED IN KEY ORDER.

SORTED LIST: DESTINATIONS LISTED IN ALPHABETICAL ORDER.

■ 1-TOUCH (DETAIL)

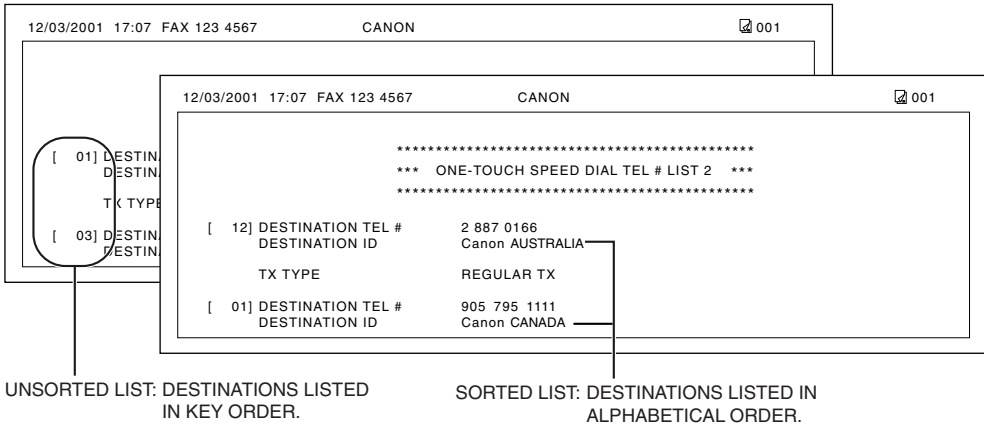

■ CODED DIAL LIST

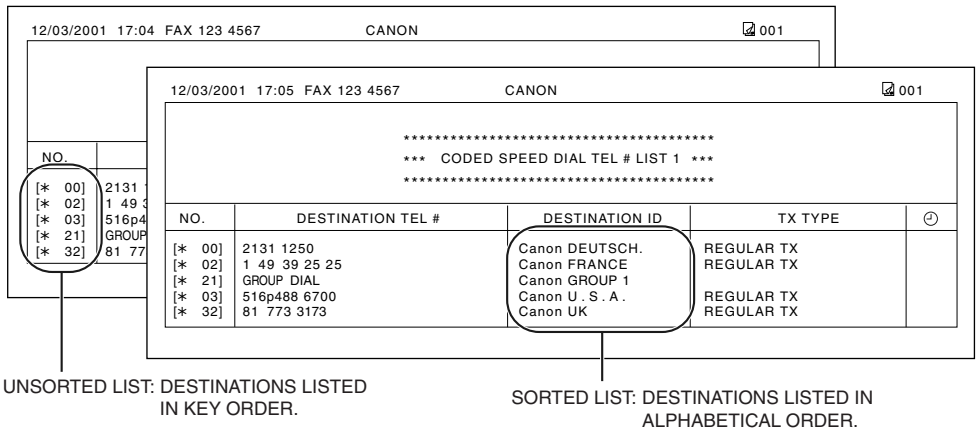

■ CODED (DETAIL)

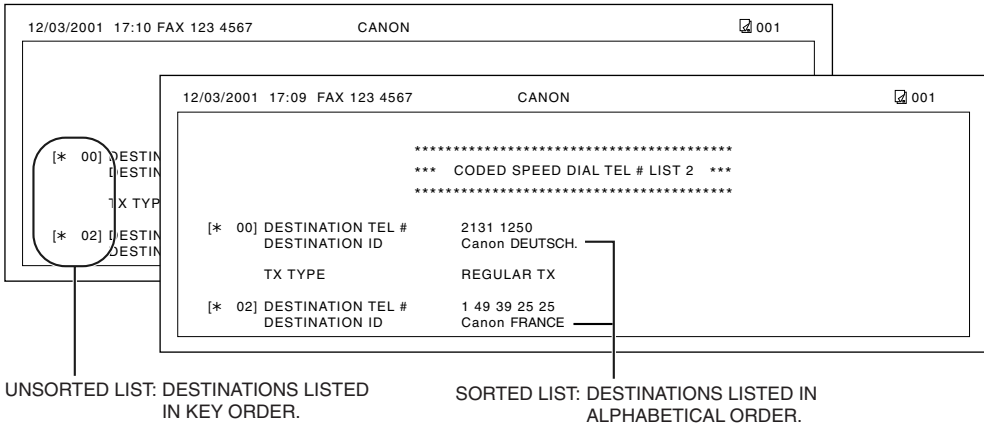

■ GROUP DIAL LIST

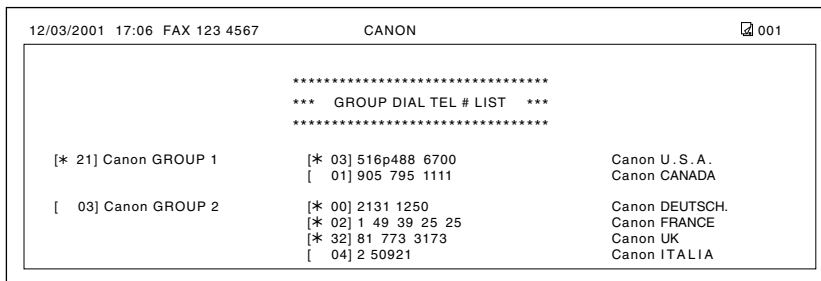

■ Canceling the Print Out List

You can cancel printing lists even after performing the printing procedure.

- 1 Press **Additional Functions**.
- 2 Use **◀ (-)** or **▶ (+)** to select 7 . PRINT LISTS.

ADDITIONAL FUNCTIONS
7 . PRINT LISTS
- 3 Press **Set**.

PRINT LISTS
1 . USER DATA
- 4 Use **◀ (-)** or **▶ (+)** to select 3 . CANCEL REPORT.

PRINT LISTS
3 . CANCEL REPORT

- 5 Press **Set**.

CANCEL REPORT?
 < YES NO >

- 6 Press **◀ (-)**.

- Printing is canceled.
- If you change your mind and want to continue the printing, press **▶ (+)**.



NOTE

- You can also cancel the printing by pressing **Function** (the **Function** key lights up) then pressing **Report**.

Registering a Password and Subaddress

The password and subaddress is required when you send faxes to the other party's fax machine that has a password and subaddress.



NOTE

- You can register the password and subaddress with a one-touch speed dialing key or coded speed dialing code.
- You must also know the password and subaddress of the other party's fax so that you can enter them on your fax. If you do not know the password and subaddress, contact the other party.
- The **Function** key will light up by pressing **Function** to be able to operate **Space**, **Delete** or **Clear**.

1 Press **Additional Functions**.

2 Use ◀ (-) or ▶ (+) to select 4 .ADD . REGISTRATION.

```
ADDITIONAL FUNCTIONS
4.ADD. REGISTRATION
```

3 Press **Set**.

```
ADD. REGISTRATION
1.1-TOUCH SPD DIAL
```

4 Use ◀ (-) or ▶ (+) to select 1 . 1-TOUCH SPD DIAL or 2 . CODED SPD DIAL.

```
ADD. REGISTRATION
Ex: 1.1-TOUCH SPD DIAL
```

5 Press **Set**.

```
1-TOUCH SPD DIAL
Ex: 01= 905795 1111
```

6 Use ◀ (-) or ▶ (+) to select the one-touch speed dialing number or coded speed dialing code.

```
1-TOUCH SPD DIAL
Ex: 02= 81 773 3115
```

7 Press **Set**.

```
1-TOUCH SPD DIAL
1.TEL NUMBER ENTRY
```

8 Use ◀ (-) or ▶ (+) to select 3.OPTIONAL SETTING.

```
1-TOUCH SPD DIAL
3.OPTIONAL SETTING
```



9 Press **Set**.

```
OPTIONAL SETTING
Ex: OFF
```

10 Use ◀ (-) or ▶ (+) to select **ON**.

```
OPTIONAL SETTING
ON
```

11 Press **Set**.

```
OPTIONAL SETTING
1.TX TIME SETTING
```

12 Use ◀ (-) or ▶ (+) to select 2 . TX TYPE.

```
OPTIONAL SETTING
2.TX TYPE
```

13 Press **Set**.

```
TX TYPE
Ex: REGULAR TX
```

14 Use ◀ (-) or ▶ (+) to select SUBADDRESS TX.

```
TX TYPE
SUBADDRESS TX
```

15 Press **Set** twice.

```
SUBADDRESS TX
1.PASSWORD
```

```
PASSWORD
```

Ex:



16 Enter a password.

Ex:

PASSWORD

 1 2 3 4 5

- If you do not need to enter a password, ignore this step.
- You can enter a password up to 20 digits long using the numeric keys, *, # or **Space**.
- Be sure to enter the password of the other party correctly, taking into account the position of spaces.
- If you make a mistake, press ◀ (-) or ▶ (+) to move the cursor to the incorrect character, then press **Delete**. Or press **Clear** to delete all characters you entered.

17 Press **Set** twice.

SUBADDRESS TX
2 . SUBADDRESS

Ex:

SUBADDRESS



18 Enter a subaddress.

Ex:

SUBADDRESS

 1 2 3 4 5 6 7 8 9 0 1 2

- You can enter a subaddress up to 20 digits long using the numeric keys, *, # or **Space**.
- Be sure to enter the subaddress of the other party correctly, taking into account the position of spaces.
- If you make a mistake, press ◀ (-) or ▶ (+) to move the cursor to the incorrect character, then press **Delete**. Or press **Clear** to delete all the characters you entered.

19 Press **Set**.

Ex:

1 - TOUCH SPD DIAL
0 3 = GROUP DIAL

20 To continue registering other passwords and subaddresses, press **Additional Functions** then repeat the procedure from step 4.

– or –
Press **Stop/Reset** to return to standby display.

Chapter 4

Sending Faxes

Preparing to Send a Fax

Documents You Can Fax

For information on the types of documents you can fax, their requirements, and details on setting up documents, → Reference Guide.

Adjusting the Quality of Your Faxes

Canon's Ultra High Quality (UHQ™) imaging technology enables you to send documents that have quality similar to the original. The machine allows you to adjust the resolution and contrast to best suit your particular document.



NOTE

- Please note that you cannot change settings while your machine is scanning a document.

Setting the Scanning Resolution

Resolution is a measure of the fineness or clarity of a printout. Low resolutions may cause text and graphics to have a jagged appearance, while higher resolutions provide smoother curves and lines, crisp text and graphics, and a better match to traditional typeface designs.



NOTE

- The higher the resolution, the higher the output quality, but the longer the transmission time.

1 Press **FAX Resolution** to select the resolution.

Ex:

FAX RESOLUTION
STANDARD

- Press **FAX Resolution** to select the following:
 - STANDARD
Suitable for most text-only documents.
 - FINE
Suitable for fine-print documents.
 - PHOTO
Suitable for documents that contain photographs.
 - SUPER FINE
Suitable for documents that contain fine print and images (the resolution is four times that of STANDARD).
 - ULTRA FINE
Suitable for documents that contain fine print and images (the resolution is eight times that of STANDARD).



2 Press **Set**.

Ex:

FAX 12/03/2001 15:30
FaxTel FINE



NOTE

- You can set the Fax Resolution so that the desired resolution such as STANDARD is automatically returned after the AUTO CLEAR function activates or documents are scanned. (→ p. 9-8)
Since RESOLUTION of FAX DEFAULT is set to OFF in the factory default setting, the resolution set using **FAX Resolution** will remain unchanged.

Dialing Methods

There are several ways of dialing the number of the party to which you want to send a fax. They are as follows:

When the fax number is not registered in the machine

- Regular Dialing
- Redialing

When the fax number is registered in the machine

- One-Touch Speed Dialing
- Coded Speed Dialing
- Group Dialing
- Directory Dialing



NOTE

- If you are unsure of the registered fax number, check the destination label, or print each list and check the numbers. (→ p. 3-9)
- For details on registering a fax number for speed dialing, → Chapter 3.

Regular Dialing

Dial a fax number by using the numeric keys, just like dialing a telephone number.

Ex:

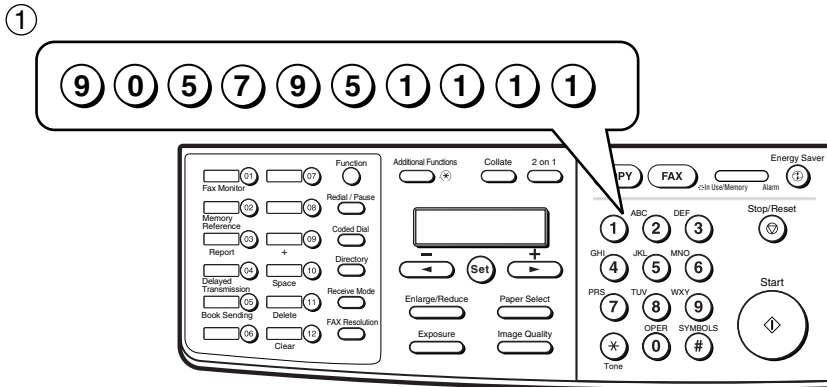

② Press **Start**.

TEL= 9057951111

Ex:

- If you enter the wrong number, press **Stop/Reset** or **Clear** to delete the number, then enter the correct number.



NOTE

- The **Function** key will light up by pressing **Function** to be able to operate **Clear**.

One-Touch Speed Dialing

Dial a fax number by pressing the one-touch speed dialing key (**01** to **12**) to which the number is assigned.

Ex:

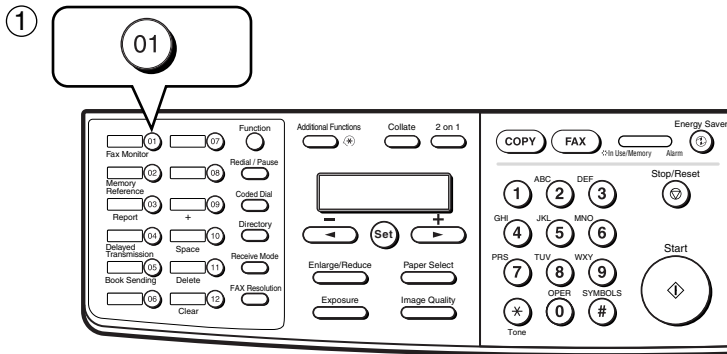

TEL= 9 05 7 95 1 111
01 Canon CANADA

Ex:

- The number registered under that one-touch speed dialing key is displayed.
- If you press the wrong key, press **Stop/Reset**. Then press the correct key.
- NO TEL # appears if no fax number is assigned to the one-touch speed dialing key you pressed.

Coded Speed Dialing

Dial a fax number by pressing **Coded Dial** followed by the two-digit code (00 to 99) to which the number is assigned.

Ex:

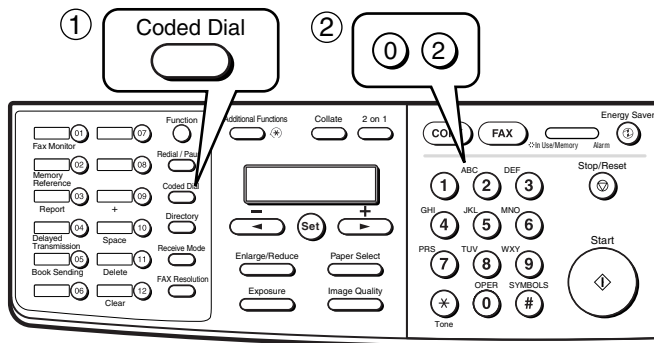

TEL= 1 49 39 25 25
*02 Canon FRANCE

Ex:

- The number registered under that coded speed dialing code is displayed.
- If you enter the wrong code, press **Stop/Reset**. Then press **Coded Dial** and enter the correct code.
- NO TEL # appears if no fax number is assigned to the coded speed dialing code you entered.

Group Dialing

Dial the fax numbers of the multiple destinations one at a time.

■ To enter a group registered under a one-touch speed dialing key:

Press the one-touch speed dialing key assigned to the group you wish to fax. (→ p. 4-3)

Ex:

TEL=GROUP DIAL 03 Canon GROUP 2

- The name of the group is displayed.
- If you press the wrong key, press **Stop/Reset**. Then press the correct key.
- NO TEL # appears if no fax number is assigned to the one-touch speed dialing key you pressed.

■ To enter a group registered under a coded speed dialing code:

Press **Coded Dial**, then using the numeric keys to enter the two-digit code assigned to the group you wish to fax. (→ p. 4-3)

Ex:

TEL=GROUP DIAL *21 Canon GROUP 1

- The name of the group is displayed.
- If you enter the wrong code, press **Stop/Reset**. Then press **Coded Dial** and enter the correct code.
- NO TEL # appears if no fax number is assigned to the coded speed dialing code you entered.

Directory Dialing

Directory dialing allows you to look up the other party's name and retrieve the number for dialing. This feature is convenient when you know the other party's name but cannot recall the One-Touch Speed Dialing key, the code for Coded Speed Dialing, or Group Dialing where the number is registered.

1 Press **Directory**.

_____ : A

- NO TEL # appears if the name of the other party is not registered and the display will return to dial entry mode.

2 Press a numeric key to enter the first letter of the name of the party you are searching for.

For example, if you want to search for a name that starts with the letter "H", press **4 (GHI)** twice.

3 Press **Set**.

- The name of the other party is displayed according to the first letter you entered.
- If there is no name that starts with the letter you entered, other names that start with the next letter will appear.



4 Press ◀ (-) or ▶ (+) to display the other names.

- Pressing ▶ (+) will display the names of other parties in alphabetical order. Pressing ◀ (-) will display them in reverse order.
- When you reach the last name, the display will return to the first name.

5 Press **Set**.

- The other party's fax number and name or GROUP DIAL and the group's name will appear.

Sending Methods

Memory Sending

The machine begins calling the other party and transmitting the information after all documents are scanned into the memory.

Since the machine is multitasking, you can even scan a document into memory while performing other tasks.

The machine has enough memory to store up to approximately 255 pages* (fewer if the document contains many graphics or particularly dense text).

* Based on ITU-T No.1 Chart, standard mode.



NOTE

- When a large amount of memory is used, **MEMORY FULL** may be displayed depending on the documents to be sent, and the machine can neither store the scanned documents in memory nor send them. In this case, print or delete any documents in memory, or select a lower fax resolution such as **STANDARD**, then send the documents.

- The **Function** key will light up by pressing **Function** to be able to operate **Delete** or **Clear**.

Using the ADF

- 1 Press **FAX** to set to Fax Mode.

Ex:

FAX 12/03/2001 15:30
FaxTel STANDARD

- 2 Prepare the document and load it face down in the ADF. (→ Reference Guide)

Ex:

MEM IN USE	0%
------------	----

(Currently used memory is displayed.)

DOCUMENT READY

(Standby to scan)

- To adjust the resolution, → p. 4-1.
- To adjust the contrast, → p. 9-4.

- 3 Dial the other party's fax number.

Ex:

TEL=	9057951111
------	------------

- For dialing methods, → p. 4-2.
- If you enter the wrong number, press **Delete** to delete the last number or press **Clear** to delete all the numbers you entered, then enter the correct number. You can also delete all the numbers by pressing **Stop/Reset**.
- If you must first dial a digit to get an outside line ("9", for example), add a pause after that digit by pressing **Redial/Pause**.

- 4 Press **Start** to begin scanning for sending.

- The machine begins calling the other party after all documents are scanned into the memory.
- If you use speed dialing or redialing, scanning starts automatically without pressing **Start** when the **TIME OUT** setting is on. (→ p. 9-6)
- To cancel sending once dialing has started, press **Stop/Reset** then press **◀ (-)**.



NOTE

- You can scan a document up to 14 inches (356 mm) long.
- You can load up to 30 pages of LTR size paper in the ADF.
- After the machine finishes scanning the document into the memory, it returns to Standby display. Then, you can make the next reservation. You can make up to 20 reservations.
- If the machine's memory becomes full while scanning your document, **MEMORY FULL** will appear in the LCD and the document being scanned stops in the ADF. Press **Set** to make the document come out automatically. If this happens, divide the documents into several sections and send each section separately.

■ Using the platen glass



NOTE

- You need to remove documents from the ADF in advance, in order to fax from the platen glass.
- You can operate **Book Sending**, **Delete** or **Clear** when the **Function** key is lit. If the **Function** key is not lit, press it. However, you do not need to press **Function** in step 3 to execute the Book Sending function if BOOK SENDING is programmed in PROGRAM 1-TOUCH KEY. (→ p. 9-4)

1 Press **FAX** to set to Fax Mode.

Ex:

FAX 12/03/2001 15:30
FaxTel STANDARD

2 Prepare the document and place it face down on the platen glass. (→ Reference Guide)

- To adjust the resolution, → p. 4-1.
- To adjust the contrast, → p. 9-4.

3 Press **Function**.

4 Press **Book Sending**.

5 Press **◀ (-)** or **▶ (+)** to select the document size.

Ex:

BOOK TX SCAN SIZE
LTR

6 Press **Set**.

7 Dial the other party's fax number.

Ex:

TEL= 9057951111

- For dialing methods, → p. 4-2.
- If you enter the wrong number, press **Delete** to delete the last number or press **Clear** to delete all the numbers you entered, then enter the correct number. You can also delete all the numbers by pressing **Stop/Reset**.
- If you must first dial a digit to get an outside line ("9", for example), add a pause after that digit by pressing **Redial/Pause**.



8 Press **Start** to begin scanning.

NEXT PAGE	: [START]
FINISH SCAN	: [SET]

9 Set the next document on the platen glass and press **Start** to begin scanning.

- Repeat for other documents.

10 After all the documents have been scanned, press **Set** to begin sending.

- To cancel sending after dialing has started, press **Stop/Reset** then press **◀ (-)**. (→ p. 4-7)



NOTE

- You can scan up to approximately 255 pages* for memory sending.
* Based on ITU-T No.1 Chart, standard mode.
- The **Function** key will light up by pressing **Function** to be able to operate **Delete** or **Clear**.
- If the machine's memory becomes full while scanning your document, MEMORY FULL will appear in the LCD and the document being scanned stops in the ADF. Press **Set** to make the document come out automatically. If this happens, divide the documents into several sections and send each section separately.

Canceling Sending

Canceling memory sending

■ To cancel memory sending while documents are being scanned using the ADF

1 Press **Stop/Reset**.

- Scanning is canceled.

■ To cancel memory sending after all documents have been scanned

■ While documents are being sent:

1 Press **Stop/Reset**.

- The machine asks you to confirm that you want to cancel.

```
CANCEL DURING TX/RX?  
< YES NO >
```

2 Press **◀ (-)** to cancel sending.

- If you change your mind and want to continue sending, press **▶ (+)**.
- The machine prints an ERROR TX REPORT. (→ p. 7-3)

■ While documents are waiting to be sent:



NOTE

- You can operate **Fax Monitor** or **Delete** when the **Function** key is lit. If the **Function** key is not lit, press it. However, you do not need to press **Function** in step 1 to execute the Fax Monitor function if FAX MONITOR is programmed in PROGRAM 1-TOUCH KEY. (→ p. 9-4)

1 Press **Function**.

2 Press **Fax Monitor**.



3 Use **◀ (-)** or **▶ (+)** to select TX RESERVE STATUS.

```
FAX MONITOR  
2.TX RESERVE STATUS
```

4 Press **Set**.

```
--:-- 0013 TX STNDBY  
Ex: 905795 1111
```

5 Use **◀ (-)** or **▶ (+)** to select the document to be canceled by checking the reservation number and the fax number.

6 Press **Delete**.

- The machine asks you to confirm that you want to delete the document.

```
OK TO DELETE?  
< YES NO >
```

7 Press **◀ (-)** to cancel sending.

- If you change your mind and want to continue sending, press **▶ (+)**.

```
TX/RX NO. 0013  
Ex: ERASING END
```



NOTE

- You can also cancel sending in Memory Reference. (→ p. 4-16)

Redialing When the Line is Busy

There are two methods of redialing: *Manual redialing* and *Automatic redialing*. This section explains these two methods.

Manual Redialing

Press **Redial/Pause** to dial the last number you dialed with the numeric keys. (This starts redialing regardless of whether automatic redialing is enabled.)

Canceling Manual Redialing

To cancel manual redialing, press **Stop/Reset**.

Automatic Redialing

The fax automatically redials twice* after the first attempt at sending fails (e.g. the line is busy). The time interval between redialing attempts is two minutes*.

The number of redialing attempts and the time interval between attempts can be adjusted by changing the settings in the **AUTO REDIAL**. Automatic redialing can also be set off and on. (→ p. 9-6)

If all attempts are unsuccessful, the machine cancels the transmission and prints an **ERROR TX REPORT**. (→ p. 7-3)

* Factory default setting

Canceling Automatic Redialing



NOTE

- If you want to cancel a transmission while the machine is waiting to redial, you must delete the document from memory using **Memory Reference**. (→ p. 4-16)

1 Wait until the machine begins redialing.

2 Press **Stop/Reset**.

- The machine asks you to confirm that you want to cancel.

```
CANCEL DURING TX/RX?  
< YES          NO >
```



3 Press **◀ (-)** to cancel redialing.

- If you change your mind and want to continue redialing, press **▶ (+)**.
- The machine prints an **ERROR TX REPORT**. (→ p. 7-3)

Sequential Broadcasting

Sending a Document to More Than One Destination

This feature allows you to scan a document once and send it to several destinations. You can send the document to a maximum of 122 destinations using a combination of the following dialing methods:

- One-touch speed dialing: up to 12 destinations
- Coded speed dialing: up to 100 destinations
- Regular dialing (using the numeric keys) or redialing: 10 destinations

You can enter the destinations in any order. (Be sure to press **Set** after your entry with the numeric keys.)



NOTE

- If you frequently send documents to the same group of destinations, you can group them and register these numbers for group dialing. You can register up to 111 fax numbers with group dialing and send the same document to these numbers. (→ p. 3-7)
- The **Function** key will light up by pressing **Function** to be able to operate **Clear**.

1 Press **FAX** to set to Fax Mode.

2 Prepare the document and load it face down in the ADF.

Ex:

MEM IN USE	0%
------------	----

(Currently used memory)

DOCUMENT READY

(Standby to scan)

- If you use the platen glass to send a document → p. 4-6.
- To adjust the resolution, → p. 4-1.
- To adjust the contrast, → p. 9-4.

3 Enter up to 122 fax numbers using any of the following methods:

■ One-touch speed dialing:

Press the desired one-touch speed dialing key(s).

Ex:

TEL=	2 50921
04	Canon ITALIA

■ Coded speed dialing:

Press **Coded Dial**, then use the numeric keys to enter the two-digit code. Repeat for other codes.

Ex:

TEL=	1 49 39 25 25
*02	Canon FRANCE

■ Regular dialing:

Use the numeric keys to enter the fax number, then press **Set**.

Ex:

TEL=	9057951111
------	------------



NOTE

- If you enter an incorrect destination, press **Clear** to delete it.
- You must enter the second fax number within five seconds of entering the first one. After that, all subsequent fax numbers must be entered within 10 seconds of each other. If you wait longer than this, the machine automatically begins scanning the document for sending. If you prefer the machine not to do this, disable the TIME OUT setting. (→ p. 9-6)
- If you want to review the numbers you entered, use ◀ (-) or ▶ (+) to scroll through the numbers.

4 Press **Start**.

- After the scanning is finished, the machine starts to dial the number.
- The machine will first send the document to the one-touch speed dialing destinations, then the coded speed dialing destinations, and finally to the destination dialed using regular dialing.
- If you prefer the machine never to scan a document automatically after a few seconds, disable the **TIME OUT** setting. (→ p. 9-6)
- To cancel sending, press **Stop/Reset** then press **◀ (-)**. Sending to all destinations specified in step 3 will be canceled. You cannot cancel just one destination.
After canceling, the machine will print a **MULTI TX/RX REPORT**. (→ p. 7-4)



- If a number is busy, the machine will continue sending to the other destinations and then redial the number that was busy.

Delayed Sending

You can use your machine to send faxes at a preset time. This feature is called *Delayed sending* or *Timer sending*. By using this feature, you can take advantage of lower long distance rates at night, for example. You can set up to 122 destinations, and up to 20 reservations of delayed sending.



NOTE

- You can perform other tasks even when you have set the machine for delayed sending.
- You can operate **Book Sending**, **Delayed Transmission** or **Clear** when the **Function** key is lit. If the **Function** key is not lit, press it. However, you do not need to press **Function** in step 1 or 2 to execute the Delayed Transmission function or Book Sending function if DELAYED TX or BOOK SENDING is programmed in PROGRAM 1-TOUCH KEY. (→ p. 9-4)

1 Prepare the document and place it on the platen glass or load it face down in the ADF.



NOTE

- When using the platen glass, press **Function** and then **Book Sending**, and select the document size with ◀ (-) or ▶ (+). In this case, you do not need to press Function in step 2.

2 Press **Function**.

3 Press **Delayed Transmission**.

4 Use the numeric keys to enter the reservation time to send faxes.

Ex:

DELAYED TX
TX TIME SETTING 15:30



5 Press **Set**.

DELAYED TX
SELECT LOCATIONS

TEL=

6 Enter a destination using a one-touch speed dialing key, coded speed dialing keys, Redial/Pause key or the numeric keys.



NOTE

- You can use the one-touch speed dialing key when the **Function** key is not lit. If the **Function** key is lit, press it.
- If you enter an incorrect destination, press **Clear** to delete it.

7 Press **Start** to begin scanning.

- When you use speed dialing, scanning starts automatically without pressing **Start** when the TIME OUT setting is on. (→ p. 9-6)
- When the time you set in step 4 comes, the machine will begin sending faxes.
- When you place the document on the platen glass, see step 8 on p. 4-6.

Confirming Transmission Status and Sending Reservation

You can check the status of sending or receiving fax, or sending reservation.



- You do not need to press **Function** in step 1 to execute the Fax Monitor function if FAX MONITOR is programmed in PROGRAM 1-TOUCH KEY. (→ p. 9-4)

Confirming Transmission Status

The sending or receiving status can be confirmed using the following method:

1 Press **Function** while **In Use/Memory** is flashing.

2 Press **Fax Monitor**.

```
FAX MONITOR
1.RX/TX STATUS
```

3 Press **Set**.

Ex:

16	:	50		00	56		TX												

Destination
TX/RX mode
TX/RX number
Scanned/received time



- To return to standby display, press **Stop/Reset**.
- If you perform the procedure above when the machine is not sending or receiving faxes, NO CURRENT RX/TX JOB will appear, and the display will return to the display shown in step 2.
- The transaction number, TX/RX means the following:
 - 0001 to 4999: A sent document;
 - 5001 to 9999: A received document.

Confirming Sending Reservation

Sending reservation or checking if there is a document being scheduled to be sent can be confirmed using the following method:

1 Press **Function** while **In Use/Memory** is lit.

2 Press **Fax Monitor**.

```
FAX MONITOR
1.RX/TX STATUS
```

3 Press **◀ (-)** or **▶ (+)**, then select **2.TX RESERVE STATUS**.

```
FAX MONITOR
2.TX RESERVE STATUS
```

4 Press **Set**.

Ex:

16	:	00		00	56		TX												

STNDBY
905 795 1111

- The sending reservation can be confirmed by checking the sending time, TX/RX NO. or fax number.

5 Press **◀ (-)** or **▶ (+)** to confirm the sending reservation.

Ex:

17	:	00		00	58		TX												

STNDBY
20 545 8584



- To return to standby display, press **Stop/Reset**.
- If you perform the procedure above when there is no sending reservation, NO DOC. STORED will appear, and the display will return to the display shown in step 3.
- You can also check the reservations by printing out the DOCUMENT MEMORY LIST. (→ p. 4-13)

Documents Stored in Memory



NOTE

- If there are no documents stored in memory, the machine will return to standby mode when you select Memory Reference.
- You do not need to press **Function** in step 1 to execute the Memory Reference function if MEMORY REFERENCE is programmed in PROGRAM 1-TOUCH KEY. (→ p. 9-4)

Printing a List of Documents in Memory

The machine can print a list of documents stored in memory, along with the transaction number (TX/RX NO.) of each document.

1 Press **Function**.

2 Press **Memory Reference**.

```
MEMORY REFERENCE
1.DOC. MEMORY LIST
```

3 Press **Set**.

- The machine prints the DOCUMENT MEMORY LIST and returns to standby mode.



NOTE

- Once you know the transaction number of a document stored in memory, you can print it or delete it. (→ pp. 4-15, 4-16)

12/03/2001 17:15 FAX 123 4567		CANON		001	
***** *** DOCUMENT MEMORY LIST *** *****					
TX/RX NO	MODE	DESTINATION TEL/ID	PGS.	SET TIME	ST. TIME
0046	DELAYED TX	[* 01] Canon TOKYO	3	12/03 16:30	14:00
0047	DELAYED TX	[04] Canon ITALIA	2	12/03 16:37	14:05
0048	DEL SQ BDCST	[* 02] Canon FRANCE	1	12/03 16:42	14:07
		[01] Canon CANADA			14:07
0049	DEL SQ BDCST	[03] Canon GROUP 2	1	12/03 16:55	14:10

■ Resending a Document in Memory

You can resend documents that are stored in memory. The machine stores faxes that are received but not printed because paper or toner has run out, a paper jam has occurred, or documents have not been transmitted due to a transmission error.

You can send such faxes to another fax machine to be printed.

1 Press **Function**.

2 Press **Memory Reference**.

```
MEMORY REFERENCE
1.DOC. MEMORY LIST
```

3 Use **◀ (-)** or **▶ (+)** to select **4 .RESEND DOCUMENT**.

```
MEMORY REFERENCE
4 .RESEND DOCUMENT
```



NOTE

- The sending error document also can be resent using **2 .MEMORY RETRANSMT**.

4 Press **Set**.

```
RESEND DOCUMENT
Ex: TX/RX NO.      0051
```



5 Use **◀ (-)** or **▶ (+)** to select the transaction number (TX/RX NO.) of the document you want to send again.

```
RESEND DOCUMENT
Ex: TX/RX NO.      0053
```

6 Press **Set**.

```
RESEND DOCUMENT
SELECT LOCATIONS
```

```
TEL=
```

7 Enter the fax number.

8 Press **Set**.

- For dialing methods, → p. 4-2.
- You need to press **Set** twice when using the numeric keys.
- The machine begins sending.

■ Printing a Document in Memory

1 Press **Function**.

2 Press **Memory Reference**.

```
MEMORY REFERENCE
1.DOC. MEMORY LIST
```

3 Use **◀ (-)** or **▶ (+)** to select 3 . PRINT DOCUMENT.

```
MEMORY REFERENCE
3 . PRINT DOCUMENT
```

4 Press **Set**.

```
PRINT DOCUMENT
Ex: TX/RX NO.      0001
```

5 Use **◀ (-)** or **▶ (+)** to select the transaction number (TX/RX NO.) of the document you want to print.

```
PRINT DOCUMENT
Ex: TX/RX NO.      0003
```

- You can enter the transaction number using the numeric keys.



6 Press **Set**.

```
PRINT 1ST PAGE ONLY?
< YES                NO >
```

7 Press **◀ (-)** to print the first page only, or press **▶ (+)** to print all pages of the document.

- The machine prints the document.



- Pressing **◀ (-)** prints the first page when sending (this is the last scanned page), not the first page when scanning with the ADF.

8 To continue printing other documents in memory, repeat the procedures from step 5. – or – Press **Stop/Reset** to return to standby display.

■ Deleting a Document from Memory

1 Press **Function**.

2 Press **Memory Reference**.

3 Use **◀ (-)** or **▶ (+)** to select 5 .DELETE DOCUMENT.

```
MEMORY REFERENCE
5 .DELETE DOCUMENT
```

4 Press **Set**.

```
DELETE DOCUMENT
Ex: TX/RX NO.      0001
```

5 Use **◀ (-)** or **▶ (+)** to select the transaction number (TX/RX NO.) of the document you want to delete.

```
DELETE DOCUMENT
Ex: TX/RX NO.      0004
```

- You can enter the transaction number using the numeric keys.



6 Press **Set**.

- The machine asks you to confirm that you want to delete the document.

```
OK TO DELETE?
< YES                NO >
```

7 Press **◀ (-)** to delete the document.

- The machine deletes the document.
- If you change your mind and want to keep the document in memory, press **▶ (+)**.

8 To continue deleting other documents in memory, repeat the procedures from step 5. – or –

Press **Stop/Reset** to return to standby display.

Chapter 5

Receiving Faxes

Different Ways to Receive a Fax

The machine provides you with several modes for receiving faxes. Once you have decided which mode is suitable for your needs, set the mode as described (→ p. 5-2). You can change the mode when the machine is in standby mode. To determine which mode best suits your requirements, refer to the table below:

Receive Mode	Main Use	Operation	Requirements
FaxTel*	Fax/Tel	Automatically switches between fax calls and voice calls. Receives faxes automatically and rings for voice calls. To set the details, → pp. 5-3, 5-4.	Telephone connected to the machine.
FaxOnly	Fax	Machine answers all calls as fax calls. It receives faxes automatically and disconnects voice calls.	Separate telephone line for fax use only.
DRPD	Fax/Tel	Allows you to have separate fax and telephone numbers that you distinguish by the type of ring. To set the details, → p. 5-5.	Subscription to a DRP service. Telephone connected to the machine.
Manual	Tel	Machine rings for every call, whether it is a fax call or a voice call. For a fax call, you have to manually activate reception of the fax.	Telephone connected to the machine.
AnsMode	Fax/Tel	Receives faxes automatically and routes voice calls to the answering machine.	Answering machine connected to the machine.

* Factory default setting

You can confirm which receive mode is set by checking the standby display. The receive mode is displayed in the lower left of the LCD.

Ex:

FAX 12/03/2001 15:30
FaxTel STANDARD

Setting the Receive Mode

The setting of the receive mode can be changed if necessary.

- 1 Press **Receive Mode** until the mode you want appears.

RECEIVE MODE
Manual

Ex:

- You can select from the following:
 - FaxTel* :
when a telephone is connected to the machine, the machine automatically switches between fax calls and voice calls.
 - FaxOnly :
if you use your machine to receive only faxes.
 - DRPD* :
to distinguish between fax and voice calls by using Distinctive Ring Patterns.
 - Manual :
when a telephone is connected to the machine, you can receive faxes by pressing **Start** before replacing the handset on the telephone.
 - AnsMode :
if you want to receive faxes automatically and route voice calls to an answering machine.

* You can set details for the FaxTel and DRPD modes. (→ pp. 5-3 to 5-5)



- 2 Press **Set**.

FAX 12/03/2001 15:30
Manual STANDARD

Ex:

The selected receive mode is set and the machine returns to standby mode. The current date and the selected receive mode are displayed.



NOTE

- The machine does not ring when it receives a fax in FaxOnly. If you want to be alerted when a fax call is received, connect a telephone to the machine, and enable the INCOMING RING setting.
- When an answering machine or a telephone with an answering machine is connected to your machine, select AnsMode. (→ p. 1-4)
- Follow these guidelines when using the machine with an answering machine:
 - Set the answering machine to answer on the first or second ring.
 - When recording the outgoing message on the answering machine, the entire message must be no longer than 15 seconds.

Ex: “Hello. I can’t answer the phone right now, but please leave a message after the beep. I’ll return your call as soon as possible.”

■ Setting the Options for FaxTel Mode

When selecting FaxTel mode, the following options can be set.

- Adjust the time the machine takes to check whether a call is from a fax machine or a telephone (RING START TIME setting).
- Adjust the length of time the machine rings when the call is a voice call (F/T RING TIME setting).
- Set whether the machine switches to receive mode after the ring time set in F/T RING TIME has elapsed (F/T SWITCH ACTION setting).

■ What Happens When FaxTel Mode is Selected

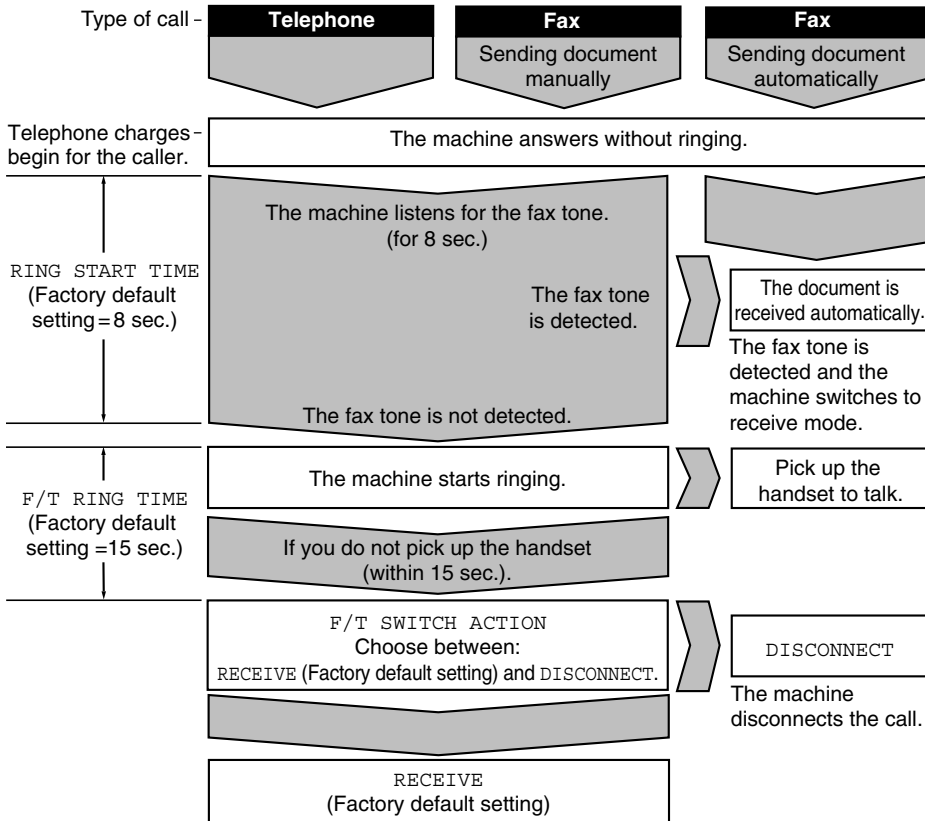

Not all fax machines are capable of sending a fax tone. For those cases if you set the F/T SWITCH ACTION to RECEIVE, the machine switches to receive mode automatically and starts receiving the document. If no document comes in, it disconnects the call after approximately 40 seconds.

1 Press **Additional Functions**.

2 Use ◀ (-) or ▶ (+) to select 3 . FAX SETTINGS.

```
ADDITIONAL FUNCTIONS
3 . FAX SETTINGS
```

3 Press **Set**.

```
FAX SETTINGS
1 . USER SETTINGS
```

4 Use ◀ (-) or ▶ (+) to select 4 . RX SETTINGS.

```
FAX SETTINGS
4 . RX SETTINGS
```

5 Press **Set**.

```
RX SETTINGS
1 . ECM RX
```

6 Use ◀ (-) or ▶ (+) to select 2 . FAX/TEL OPT . SET.

```
RX SETTINGS
2 . FAX/TEL OPT . SET
```

7 Press **Set** twice.

```
FAX/TEL OPT . SET
1 . RING START TIME
```

Ex:

```
RING START TIME
08SEC
```

8 Use ◀ (-) or ▶ (+) to set the time the machine waits before ringing when it receives a call.

Ex:

```
RING START TIME
09SEC
```

- You can select from 0 to 30 seconds.
- The default setting is eight seconds.
- You can use the numeric keys instead of using ◀ (-) or ▶ (+) to set the time.



9 Press **Set** twice.

```
FAX/TEL OPT . SET
2 . F/T RING TIME
```

Ex:

```
F/T RING TIME
015SEC
```

10 Use ◀ (-) or ▶ (+) to set the time the machine rings while waiting for someone to pick up the handset.

Ex:

```
F/T RING TIME
030SEC
```

- You can select from 15 to 300 seconds.
- The default setting is 17 seconds.

11 Press **Set** twice.

```
FAX/TEL OPT . SET
3 . F/T SWITCH ACTION
```

Ex:

```
F/T SWITCH ACTION
RECEIVE
```

12 Use ◀ (-) or ▶ (+) to select RECEIVE or DISCONNECT .

Ex:

```
F/T SWITCH ACTION
DISCONNECT
```

- This setting tells the machine what to do if no one picks up the handset within the specified ring time set in step 10.
- Select RECEIVE to receive the call, or DISCONNECT to disconnect the call.
- The default setting is RECEIVE.

13 Press **Set**.

```
RX SETTINGS
3 . DRPD : SELECT FAX
```

14 Press **Stop/Reset** to return to standby display.

■ Setting the Options for Distinctive Ring Pattern Detection Feature: DRPD

Some telephone companies offer a Distinctive Ring Pattern (DRP) service whereby they assign two or more telephone numbers with distinctive ring patterns to a single telephone line. If your telephone company offers such a service, you can have both a fax number(s) and a telephone number(s) for your machine using only one telephone line.

Your machine will automatically monitor incoming calls and based on the distinctive ring pattern, it will determine if the call is from a fax machine trying to send a document or from a telephone trying to make a voice call.

Use the information in this section to set up the machine for use with a DRP service. For more details on the DRP service, contact your local telephone company. (Your telephone company may have a different name for this service. Also, this service may not be offered in all areas.)

Types of Ring Patterns

Your telephone company will assign a distinctive ring pattern to each number when you order the DRP service. See the fax ring pattern to match that assigned by the telephone company.

1 Press **Additional Functions**.

2 Use ◀ (-) or ▶ (+) to select 3 . FAX SETTINGS.

```
ADDITIONAL FUNCTIONS
3 . FAX SETTINGS
```

3 Press **Set**.

```
FAX SETTINGS
1 . USER SETTINGS
```

4 Use ◀ (-) or ▶ (+) to select 4 . RX SETTINGS.

```
FAX SETTINGS
4 . RX SETTINGS
```

5 Press **Set**.

```
RX SETTINGS
1 . ECM RX
```

6 Use ◀ (-) or ▶ (+) to select 3 . DRPD : SELECT FAX.

```
RX SETTINGS
3 . DRPD : SELECT FAX
```



7 Press **Set**.

```
DRPD : SELECT FAX
DOUBLE RING
```

Ex:

8 Use ◀ (-) or ▶ (+) to select the type of ring pattern for the number the machine uses.

```
DRPD : SELECT FAX
SHORT - SHORT - LONG
```

Ex:

- Select the type of ring pattern of which your telephone company assigned for the number.
- You can select from the following:
 - DOUBLE RING
 - SHORT-SHORT-LONG
 - SHORT-LONG-SHORT
 - OTHER RING TYPE
 - NORMAL RING

9 Press **Set**.

```
RX SETTINGS
4 . INCOMING RING
```

10 Press **Stop/Reset** to return to standby display.

Receiving Faxes Manually

In Manual mode, if you connect a telephone to your machine, you can receive voice calls as well as manually activate reception of faxes. You can activate reception from the machine or from the telephone connected to the machine (this is called *Remote receiving*).



NOTE

- For this mode, you need to connect a telephone to your machine. (→ p. 1-4)
- Make sure there are no documents in the ADF.
- Make sure the REMOTE RX setting is enabled. (→ p. 9-7)
- If your telephone line uses rotary pulse and the telephone connected to the machine cannot be switched to tone dialing, you cannot activate Remote receiving.

1 Make sure Manual is displayed in the LCD.

Ex:

FAX 12/03/2001 15:30
Manual STANDARD

- To set Manual, → p. 5-2.

2 Make sure you have connected a telephone to the machine.

3 When you hear the telephone ring, pick up the handset.

4 ■ If you hear a person's voice:

Start your conversation. If the caller wants to send a fax after talking to you, ask them to press the start key on their fax machine.

When you hear a slow beep, press **Start** on your machine to begin receiving the fax. Hang up the handset.

■ If you hear a slow beep tone or silence:

Someone is trying to send you a fax.

If the telephone is close to your machine, press **Start** on the machine to begin receiving the fax. Hang up the handset.



NOTE

- If no paper is loaded in the cassette, the LCD displays RECEIVED IN MEMORY. When paper is loaded, the machine automatically resumes printing.
- The machine will beep and HANG UP PHONE will be displayed if the handset is not hung up properly. Make sure the handset is seated properly in its cradle. If you do not want the machine to beep, disable the OFFHOOK ALARM setting. (→ p. 9-5)
- If the telephone is located away from your machine, dial 25 (the remote receiving ID) on your telephone and hang up. When your telephone line uses rotary pulse, switch to tone dialing on your telephone before dialing 25 (the remote receiving ID).
- You can change the number for the remote receiving ID, with a combination of two characters using 0 to 9, * and #, or disable remote receiving. (→ p. 9-7)
- If you have an answering machine connected to your machine that can carry out remote-control operations (controlling your answering machine from a remote telephone), the security code for this function may be the same as the remote receiving ID. If so, make sure you change the machine's remote receiving ID to make it distinct from the answering machine's security code. (→ p. 9-7)

Registering a Password and Subaddress for Polling

The polling feature allows you to request a document to be faxed to you from another fax machine. The sender only needs to make sure that the document is on his fax machine and ready to be sent. When this machine polls the sender's machine, the document is sent automatically.



NOTE

- You can register a password and subaddress with a one-touch speed dialing key or coded speed dialing code.
- You must know if the other party's fax is holding the document under both a password and subaddress or only a password or subaddress. You must also know the password and subaddress so that you can enter them on your fax. If you do not know the password and subaddress, contact the other party.
- The **Function** key will light up by pressing **Function** to be able to operate **Space**, **Delete** or **Clear**.

1 Press **Additional Functions**.

2 Use ◀ (-) or ▶ (+) to select 4 .ADD . REGISTRATION.

```
ADDITIONAL FUNCTIONS
4.ADD. REGISTRATION
```

3 Press **Set**.

```
ADD. REGISTRATION
1.1-TOUCH SPD DIAL
```

4 Use ◀ (-) or ▶ (+) to select 1 .1-TOUCH SPD DIAL or 2 .CODED SPD DIAL.

Ex:

```
ADD. REGISTRATION
1.1-TOUCH SPD DIAL
```

5 Press **Set**.

Ex:

```
1-TOUCH SPD DIAL
01=          905795 1111
```

6 Use ◀ (-) or ▶ (+) to select the one-touch speed dialing number or coded speed dialing code.

Ex:

```
1-TOUCH SPD DIAL
02=          81 773 3115
```

7 Press **Set**.

```
1-TOUCH SPD DIAL
1.TEL NUMBER ENTRY
```



8 Use ◀ (-) or ▶ (+) to select 3.OPTIONAL SETTING.

```
1-TOUCH SPD DIAL
3.OPTIONAL SETTING
```

9 Press **Set**.

Ex:

```
OPTIONAL SETTING
OFF
```

10 Use ◀ (-) or ▶ (+) to select **ON**.

```
OPTIONAL SETTING
ON
```

11 Press **Set**.

```
OPTIONAL SETTING
1.TX TIME SETTING
```

12 Use ◀ (-) or ▶ (+) to select 2 .TX TYPE.

```
OPTIONAL SETTING
2.TX TYPE
```

13 Press **Set**.

Ex:

```
TX TYPE
SUBADDRESS TX
```

14 Use ◀ (-) or ▶ (+) to select POLLING RX.

```
TX TYPE
POLLING RX
```



15 Press **Set** twice.

POLLING RX
1 . PASSWORD

Ex: PASSWORD

16 Enter a password.

Ex: PASSWORD 1 2 3 4 5

- You can enter a password up to 20 digits long using the numeric keys, *, # or **Space**.
- Be sure to enter the password of the other party correctly, taking into account the position of spaces.
- If you make a mistake, press **Delete** to delete the last number or press **Clear** to delete all numbers you entered.

17 Press **Set** twice.

Ex: SUBADDRESS



18 Enter a subaddress.

Ex: SUBADDRESS
1 2 3 4 5 6 7 8 9 0 1 2

- You can enter a subaddress up to 20 digits long using the numeric keys, *, # or **Space**.
- Be sure to enter the subaddress of the other party correctly, taking into account the position of spaces.
- If you make a mistake, press **Delete** to delete the last character or press **Clear** to delete all the characters you entered.

19 Press **Set**.

Ex: 1 - TOUCH SPD DIAL
0 3 = GROUP DIAL

- 20** To continue registering other passwords and subaddresses, press **Additional Functions** then repeat the procedure from step 4.
– or –
Press **Stop/Reset** to return to standby mode.

Receiving While Performing Other Tasks

Since the machine is a multitasking device, it can receive faxes and voice calls while you are performing other tasks.

If you receive a fax while you are performing certain tasks, the machine stores the incoming fax in memory. Then, as soon as you finish your task, the machine automatically prints the fax.



NOTE

- If you are copying or printing, printing of the received fax is suspended and then resumed after copying or printing is finished.

Receiving Faxes in Memory When a Problem Occurs

If the machine encounters a problem when it is receiving a fax, the machine automatically stores the unprinted pages of the fax in memory, and the LCD displays RECEIVED IN MEMORY as well as one or more messages. When the problem is cleared, the machine automatically prints the fax which was stored in memory. For an explanation of the message(s) and details on the action to take, → p. 8-1.



NOTE

- The machine memory can store up to approximately 255 pages.*
- Once the pages are printed, they are deleted from memory.
- If the memory becomes full, you will not be able to receive the remaining pages. Contact the other party and ask them to resend the remainder of the fax.

* Based on the condition, that the other party sends the fax by imageCLASS D680, with ITU-T No.1 Chart, standard mode.

The maximum number of pages, that the machine's memory can store, differs depending on the other party's machine.

Canceling Receiving

Follow this procedure if you want to stop receiving a fax before reception is completed:

1 Press **Stop/Reset**.

- The machine asks you to confirm that you want to cancel.

```
CANCEL DURING TX/RX?  
< YES          NO >
```



2 Press **◀ (-)** to cancel receiving.

- If you change your mind and want to continue receiving, press **▶ (+)**.

Chapter 6

Special Features

Special Dialing

This section explains special dialing features, such as dialing through a switchboard, dialing an overseas number, and switching temporarily to tone dialing.

Dialing Through a Switchboard

A PBX (Private Branch Exchange) is an on-site telephone switchboard. If your machine is connected through a PBX or other telephone switching system, you have to dial the outside line access number first, and then dial the number of the party you are calling.

Dialing an Overseas Number (With Pauses)

When you dial or register an overseas number, you may need to insert a pause within and/or after the number. The length and location of the pause depends on the telephone system of your country.



NOTE

- The **Function** key will light up by pressing **Function** to be able to operate **Delete** or **Clear**.

1 Press **FAX** to set to Fax Mode.

Ex:

FAX 12/03/2001 15:30
FaxTel STANDARD

2 Prepare the document and load it facing down into the ADF.

Ex:

MEM IN USE	0%
------------	----

(Currently used memory)

DOCUMENT READY

(Standby to scan)

- If you use the platen glass to send a document, → p. 4-6.

3 Use the numeric keys to dial the international access code.

Ex:

TEL=	00
------	----

- If you enter the wrong number, press **Stop/Reset**, then enter the correct number.
- For details on international access codes, contact your local telephone company.

4 If necessary, press **Redial/Pause** to enter a pause.

Ex:

TEL=	00P
------	-----



- A pause entered within a number (p) is two seconds long.
- For a longer pause, press **Redial/Pause** again for another two-second pause. Alternatively, you can change the length of the pause. (→ p. 9-5)

5 Use the numeric keys to dial the country code, the area code, and the fax/telephone number of the other party.

Ex:

TEL=	00p81123
------	----------

- If you enter the wrong number, press **Delete** to delete the last number, then enter the correct number. Or, press **Clear** or **Stop/Reset** to delete all the numbers you entered, then start again from step 3.

6 If necessary, press **Redial/Pause** to enter a pause at the end of a number.

Ex:

TEL=	00p81123P
------	-----------

- A pause at the end of a number (P) is fixed to 10 seconds.

7 Press **Start** to begin scanning for sending.

- To cancel sending after dialing has started, press **Stop/Reset** then ◀ (–). (→ p. 4-7)



NOTE

- To take advantage of the speed dialing features of your machine, register frequently used overseas numbers for one-touch or coded speed dialing. (→ pp. 3-2, 3-4)

Switching Temporarily to Tone Dialing

Many information services for banks, airline reservations, hotel reservations, etc., require tone dialing for their services. If your machine is connected to a rotary pulse line, follow this procedure to set the machine temporarily for tone dialing:

1 Press **FAX** to set to Fax Mode.

Ex:

FAX 12/03/2001 15:30
FaxTel STANDARD

2 Pick up the handset of your telephone.

3 Enter a destination using the numeric keys on your telephone or using a one-touch speed dialing key, coded speed dialing code, Redial/Pause key or the numeric keys on the machine.

4 When the recorded message of the information service answers, press *** (Tone)** to switch to tone dialing.

Ex:

TEL = T

- When *** (Tone)** is pressed, T is displayed in the LCD.
- If your telephone line uses tone dialing, go to the next step.



5 Use the numeric keys on the machine to enter the numbers requested by the information service.

Ex:

TEL = T 3 4

- Numbers entered after pressing *** (Tone)** will be dialed using tone dialing.
- After pressing *** (Tone)**, you cannot use the numeric keys on the telephone. Use the numeric keys on the machine.

6 If you want to receive faxes, press **Start**.

7 Hang up to disconnect the call.

- Tone dialing is canceled when you disconnect the call.

Chapter 7

Reports and Lists

Summary of Reports and Lists

The table below shows the reports and lists that can be printed from your machine. Refer to the pages indicated for more details.



NOTE

- Make sure that LTR or LGL-size paper is loaded in the cassette. If a different paper size is loaded, the report or list cannot be printed. Also, you cannot use the multi-purpose tray for printing the report or list.

Report or List	Description	Details
USER'S DATA LIST	Lists the current settings of your machine and the registered sender information.	p. 2-6
ACTIVITY REPORT	Shows recent facsimile transactions performed by your machine. You can enable or disable automatic printing of this report after every 20 transactions. You can also manually set the machine to print it.	p. 7-2
TX (Transmission) REPORT	Prints after transmission of a document. You can enable or disable this feature, or set the machine to print a report only when an error occurs. You can also set the machine to print the first page of the document under the transmission report to remind you of the contents of the document.	p. 7-3
RX (Reception) REPORT	Prints after reception of a document. You can enable or disable this feature, or set the machine to print a report only when an error occurs.	p. 7-4
DOCUMENT MEMORY LIST	Lists the documents currently stored in the machine's memory.	p. 4-13
1-TOUCH LIST/ 1-TOUCH (DETAIL)	Lists the numbers and names registered under one-touch speed dialing keys.	pp. 3-9, 3-10
CODED DIAL LIST/ CODED (DETAIL)	Lists the numbers and names registered under coded speed dialing codes.	pp. 3-10, 3-11
GROUP DIAL LIST	Lists groups registered under one-touch speed dialing keys and coded speed dialing codes.	p. 3-11

ACTIVITY REPORT

The machine is factory-set to automatically print an ACTIVITY REPORT after every 20 transactions. If you want to print an ACTIVITY REPORT before it is automatically printed, follow this procedure:



- If you prefer the machine not to print an ACTIVITY REPORT after every 20 transactions, set ACTIVITY REPORT to OFF. (→ p. 9-5)
- You do not need to press **Function** in step 1 to execute the Report function if REPORT is programmed in PROGRAM 1-TOUCH KEY. (→ p. 9-4)

1 Press **Function**.

2 Press **Report**.

3 Use **◀ (-)** or **▶ (+)** to select 1 .ACTIVITY REPORT .

```
REPORT
1 .ACTIVITY REPORT
```

4 Press **Set**.

- The machine prints an ACTIVITY REPORT and returns to standby mode.

Transactions in an ACTIVITY REPORT are listed chronologically.

12/03/2001 17:28 FAX 123 4567		CANON		001	
***** *** ACTIVITY REPORT *** *****					
ST. TIME	DESTINATION TEL/ID	NO.	MODE	PGS.	RESULT
*12/03 15:10	905 795 1111	5001	AUTO RX ECM	1	OK 00'33
*12/03 15:14	905 795 1111	5002	AUTO RX ECM	1	OK 00'24
*12/03 15:22	Canon TOKYO 03 3758 2111	0001	SEQ. B'CAST ECM	3	OK 01'18
*12/03 15:24	Canon AUSTRALIA 2 887 0166	0001	SEQ. B'CAST ECM	3	OK 01'18
*12/03 16:10	905 795 1111	5003	AUTO RX ECM	1	OK 00'18
*12/03 16:16	2 887 0166	5004	AUTO RX ECM	4	OK 00'59
*12/03 16:27	Canon EUROPE 20 545 8545	0002	TRANSMIT ECM	1	OK 01'20
*12/03 16:30	Canon EUROPE 20 545 8545	0003	TRANSMIT ECM	1	OK 04'12
12/03 16:53	03 3758 2111	5005	AUTO RX ECM	1	OK 01'16
12/03 17:08	Canon AUSTRALIA 2 887 0166	0004	TRANSMIT	3	NG 00'51
12/03 17:20	CANON OPTICS 1 432 2060	0005	TRANSMIT	0	NG 00'01
				0	#0018

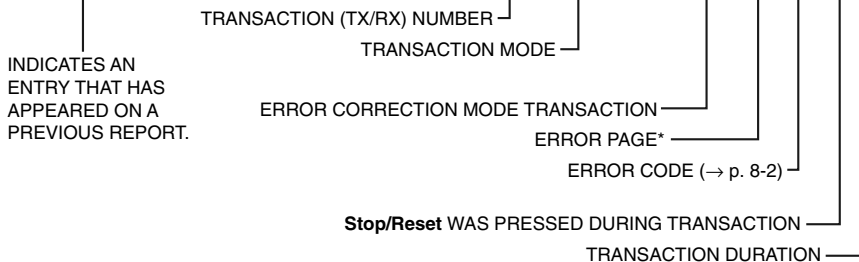

* The number of pages that have been printed and the number of pages indicated on the report may not be the same.

TX (Transmission) REPORT

The machine is factory-set to print a TX (transmission) REPORT only when an error occurs during sending. To change this setting, → p. 9-5.

If you set the machine to print a report, a TX REPORT or an ERROR TX REPORT, similar to the ones below, will be printed depending on the setting you select.

12/03/2001 17:47 FAX 123 4567 CANON 001

*** TX REPORT ***

TRANSMISSION OK

TX/RX NO 0003
DESTINATION TEL # 1 432 2060

12/03/2001 17:21 FAX 123 4567 CANON 001

*** ERROR TX REPORT ***

TX FUNCTION WAS NOT COMPLETED

TX/RX NO 0004
DESTINATION TEL # 20 545 8545
DESTINATION ID Canon EUROPE
ST. TIME 12/03 17:21
TIME USE 00'18
PAGES SENT 1
RESULT NG #0018 BUSY/NO SIGNAL

●

THE SLEREXE COMPANY LIMITED

SAPORS LANE•BOOLE•DORSET•BH25 8ER
TELEPHONE BOOLE (945 13) 51617 – FAX 1234567

Our Ref. 350/PJC/EAC December 3, 2001

Dr. P. N. Cundall,
Mining Surveys Ltd.,
Holroyd Road,
Reading,
Berks.

OK: TRANSMISSION SUCCESSFUL
NG: SOME OR NO PAGES SENT

NUMBER OF PAGES SENT
TRANSMISSION DURATION
TRANSMISSION TIME

IF YOU ENABLE THE REPORT WITH TX IMAGE SETTING (→ p. 9-5), THE FIRST PAGE OF THE DOCUMENT WILL PRINT ON THE REPORT TO REMIND YOU OF THE CONTENTS OF THE DOCUMENT .

MULTI TX/RX (Transaction) REPORT

If the transmission was a sequential broadcast, a MULTI TX/RX (transaction) REPORT, similar to the one below, will be printed.

It will also be printed if you select OUTPUT YES under TX REPORT or RX REPORT in the Report Settings (→ p. 9-5).

12/03/2001 18:16 FAX 123 4567		CANON		001	
***** *** MULTI TX/RX REPORT *** *****					
TX/RX NO	0054				
PGS.	1				
TX/RX INCOMPLETE TRANSACTION OK	[* 00] 2131 1250			Canon DEUTSCH.	
	[* 02] 1 49 39 25 25			Canon FRANCE	
	[01] 905 795 1111			Canon CANADA	
ERROR INFORMATION					

RX (Reception) REPORT

The machine is factory-set not to print an RX (reception) REPORT even if an error occurs during reception. To change this setting, → p. 9-5.

If you set the machine to print a report, an RX REPORT, similar to the one below, will be printed.

12/03/2001 17:52 FAX 123 4567		CANON		001	
***** *** RX REPORT *** *****					
RECEPTION OK					
TX/RX NO	5004				
DESTINATION TEL #	905 795 1111				
DESTINATION ID	Canon CANADA				
ST. TIME	12/03 17:52				
TIME USE	01'59				
PGS.	4				
RESULT	OK				

OK: RECEPTION SUCCESSFUL
NG: SOME OR NO PAGES RECEIVED
NUMBER OF PAGES RECEIVED
RECEPTION DURATION
RECEPTION TIME

Chapter 8

Troubleshooting

LCD Messages

The following messages are displayed in the LCD when the machine performs a function or if it encounters an error.

This section describes messages related to fax functions. For other messages → Reference Guide.

Message	Cause	Action
CHANGE DOCUMENT	When using the platen glass to send documents with Book sending, you pressed Start without changing the document.	Place the next document on the platen glass then press Start .
DOCUMENT TOO LONG	The length of the document exceeds 356 mm.	The length of the document should be within 356 mm.
HANG UP PHONE	The handset is not placed in the handset cradle correctly.	Replace the handset correctly.
MEM IN USE <i>nn</i> %	Shows the percentage of memory currently in use.	Wait for the machine to send any faxes in memory. Also, print or delete any documents in memory you no longer need. (→ pp. 4-15, 4-16)
MEMORY FULL	The memory becomes full during the document scanning.	When sending the document, divide it into a few parts or select a lower fax resolution. If you need more space, wait for the machine to send any faxes. Also, print or delete any documents in memory you no longer need. (→ pp. 4-15, 4-16) If the machine's memory becomes full while scanning documents using the ADF, the document being scanned stops in the ADF. Press Set to make the document come out automatically.
NO TEL #	The one-touch speed dialing key or coded speed dialing code you entered has not been registered.	Register the one-touch speed dialing key or coded speed dialing code. (→ pp. 3-2, 3-4)
RECEIVED IN MEMORY	The machine received the fax in memory because paper or toner ran out, or a paper jam occurred.	Load paper in the cassette (→ Set-up Instructions), replace the cartridge (→ Reference Guide), or clear the paper jam. (→ Reference Guide)
TX/RX NO. <i>nnnn</i> *	When the machine sends or receives a fax, it assigns a unique identification number (<i>nnnn</i>).	Write the number down if you will need it later.

* The identification number does not appear in the standby display. It appears when scanning documents, operating Fax Monitor or Memory Reference, or receiving faxes in Manual mode.

Faxing Problems

Sending Problems

■ You cannot send a fax.

The machine may have overheated.

- Unplug the machine and let it cool for about 10 minutes. Then plug in the machine and try sending again.

The machine may not be set for the type of telephone line in use (pulse/tone).

- Make sure the machine is set for the correct telephone line type. (→ p. 2-7)

The document may not have been loaded.

- Remove the document, stack it if necessary, and place it on the platen glass or load it into the ADF correctly. (→ Reference Guide)

The one-touch speed dialing key or coded speed dialing code you entered may not be registered for the feature you want to use.

- Check the one-touch speed dialing key or coded speed dialing code and make sure it is registered correctly. (→ Chapter 3)

You dialed or have been provided with an incorrect number.

- Dial the number again, or check that you have the correct number.

The other party's fax machine may be out of paper.

- Call the other party and ask them to make sure paper is loaded in their fax machine.

There may be other documents being sent from memory.

- Allow time for those documents to finish sending.

An error may have occurred during sending.

- Print an ACTIVITY REPORT and check for an error. (→ p. 7-2)

The telephone line may not be working properly.

- Make sure there is a dial tone when you lift the handset of the telephone connected to the machine. If there is no dial tone, contact your local telephone company.

The receiving fax machine may not be a G3 fax machine.

- Make sure the receiving fax machine is compatible with the machine (which is a G3 fax machine).

The other party's telephone may be busy or the other party's fax machine may be turned OFF.

BUSY/NO SIGNAL is shown on the ERROR TX REPORT.

- The telephone number you dialed is busy. Try sending the document at a later time.
- The other party's fax machine is not working. Contact the other party and have them check their fax machine.

The receiving fax machine did not answer within 55 seconds (after all automatic redialing attempts).

- Contact the other party and have them check their fax machine. For an overseas call, add pauses to the registered number. (→ p. 6-1)

■ Faxes sent from the machine are spotted or dirty.

The receiving fax machine may not be working properly.

- Check the machine by making a copy (→ Reference Guide). If the copy is clear, the problem may be in the receiving fax machine. If the copy is spotted or dirty, clean the platen glass or the rollers inside the main unit. (→ Reference Guide)

The document may not have been loaded.

- Remove the document, stack it if necessary, and place it on the platen glass or load it into the ADF correctly. (→ Reference Guide)

■ Cannot send using Error Correction Mode (ECM).

The other party's fax machine may not support ECM.

- If the other party's fax machine does not support ECM, then the document is sent in normal mode without error checking.

ECM may be disabled.

- Make sure ECM is on. (→ p. 9-5)

■ Errors occur frequently while sending.

The telephone lines may be in poor condition, or you may have a bad connection.

- Lower the transmission speed. (→ p. 9-4)

■ Receiving Problems

■ Cannot receive a fax automatically.

The machine may not be set to receive automatically.

- For the machine to receive faxes automatically, the receive mode must be set to FaxTel, FaxOnly, AnsMode or DRPD (→ Chapter 5). If you have set AnsMode, confirm that an answering machine is connected to the machine and that it is turned on with an outgoing message properly recorded. (→ p. 5-2)

The machine's memory is full.

- Print out or delete any documents stored in memory to free up space in the machine's memory. (→ pp. 4-15, 4-16)

An error may have occurred during reception.

- Print an ACTIVITY REPORT and check for an error. (→ p. 7-2)

No paper in the cassette.

- Make sure paper is loaded in the cassette. (→ Set-up Instructions)

The telephone line may not be connected properly.

- Make sure all line connections are secure. (→ p. 1-3)

■ The machine does not switch automatically between telephone and fax reception.

The machine may not be set to switch automatically between telephone and fax reception.

- For the machine to switch automatically, the receive mode must be set to FaxTel, AnsMode or DRPD (→ Chapter 5). If you have set AnsMode, confirm that an answering machine is connected to the machine and that it is turned on with an outgoing message properly recorded. (→ p. 5-2)

The sending fax machine cannot send the CNG signal that tells the machine that the incoming signal is a fax.

- Some fax machines cannot send the CNG signal that tells your machine the incoming call is from a fax machine. In such cases, you will have to receive the fax manually. (→ p. 5-6)

■ Cannot receive a document manually.

You may have disconnected the call by pressing Start or dialing the remote receiving ID after hanging up the handset.

- Always press **Start** or dial the remote receiving ID before hanging up the handset. Otherwise you will disconnect the call.
- When your telephone line uses rotary pulse, switch to tone dialing on your telephone before dialing 25 (the remote receiving ID).

■ Print quality is poor.

You may not be using the correct type of paper.

- Make sure you load paper that meets the paper requirements for the machine. (→ Reference Guide)

The sending fax machine may not be functioning properly.

- The sending fax machine usually determines the fax's quality. Call the sender and have them make sure the top cover and scanning glass of their fax machine are clean.

Error Correction Mode (ECM) may be disabled.

- Make sure ECM is on. (→ p. 9-6)

■ Faxes do not print.

The Cartridge may not be installed properly.

- Make sure the Cartridge is installed properly. (→ Reference Guide)

The Cartridge may need to be replaced.

- Determine if the problem is with the Cartridge, and replace if necessary. (→ Reference Guide)

No paper may be loaded in the cassette.

- Make sure paper is loaded in the cassette. (→ Set-up Instructions)

■ Faxed images are blotched or uneven.

The telephone lines may be in poor condition, or you may have a bad connection.

- Error Correction Mode (ECM) sending/receiving should eliminate such problems. However, if the telephone lines are in poor condition, you may have to try again.

The sending fax machine may not be functioning properly.

- The sending fax machine usually determines the fax's quality. Call the sender and have them make sure the top cover and scanning glass of their fax machine are clean.

■ Cannot receive using Error Correction Mode (ECM).

The other party's fax machine may not support ECM.

- If the other party's fax machine does not support ECM, then the document is received in normal mode without error checking.

ECM may be disabled.

- Make sure ECM is on. (→ p. 9-6)

■ Errors occur frequently while receiving.

The telephone lines may be in poor condition, or you may have a bad connection.

- Lower the reception speed. (→ p. 9-4)

The sending fax machine may not be functioning properly.

- Call the sender and have them check that their fax machine is functioning properly.

Telephone Problems

■ You cannot dial.

The telephone line may not be connected properly.

- Make sure all line connections are secure. (→ p. 1-3)

The machine may not be set for the type of telephone line in use (pulse/tone).

- Make sure the machine is set for the correct telephone line type. (→ p. 2-7)

■ The telephone disconnects while you are talking.

The telephone line may not be plugged in securely.

- Check that the modular cord is connected securely to the jacks on the machine, the telephone jack on your wall and the connecting jack on your telephone.

If a Power Cut Occurs

If power is suddenly lost due to an outage or accidental unplugging, a built-in battery retains the user data settings and the speed dialing settings. Any sent or received documents stored in memory are backed up for about two hours.

During a power cut, functions are limited as follows:

- You cannot send, receive, or copy documents.
- You can make or receive calls.

When power is restored to the machine, the machine will automatically print a list of documents that were stored in memory at the time of the power cut.

12/03/2001 15:38 FAX 123 4567		CANON		001	
***** *** MEMORY CLEAR REPORT *** *****					
MEMORY FILES DELETED					
TX/RX NO	MODE	DESTINATION TEL/ID	PGS.	SET TIME	ST. TIME
0023	SEQ. B'CAST	[01]Canon CANADA [05]Canon OPTICS	3	12/03 14:23	
0024	TRANSMIT	[* 32]Canon UK	1	12/03 14:28	



NOTE

- Make sure that LTR-size paper is loaded in the cassette. If a different paper size is loaded, the report cannot be printed. Also, you cannot use the multi-purpose tray for printing the report.
- If there is no paper in the cassette or no toner in the cartridge when power is restored, the MEMORY CLEAR REPORT will not be printed.

If You Cannot Solve the Problem

If you have a problem with your machine and you cannot solve it by referring to the information in this chapter and in the Reference Guide, contact your service representative.

Canon's support personnel are trained in the technical support of Canon's products and should be able to help you with your problem. The details on contacting your service representative, → Reference Guide.

Chapter 9

Setting the Additional Functions

Understanding the “Additional Functions”

The menus of the Additional Functions can allow you to specify or register the various settings. Available menus differ depending on the machine type. This section explains the procedure to access the menus, and the contents of the menus only related to the fax functions.



NOTE

- For the menus related to the common settings and the copy functions, → Reference Guide.
- Before adjusting any settings, you may want to print the USER'S DATA LIST to check the current settings. (→ p. 2-6)

Accessing the Additional Functions

1 Press **Additional Functions** to display the menus.

- The Additional Functions key blinks.

2 Press **◀ (-)** or **▶ (+)** to select the menu you want to change.

Ex:

ADDITIONAL FUNCTIONS
3 . FAX SETTINGS

3 Press **Set**.

FAX SETTINGS
1 . USER SETTINGS

4 Use **◀ (-)** or **▶ (+)** to select the sub menu you want to change.

Ex:

FAX SETTINGS
2 . REPORT SETTINGS

5 Press **Set**.

REPORT SETTINGS
1 . TX REPORT



NOTE

- For details of the submenus, → pp. 9-2 to 9-10.
- After selecting the item or value with **◀ (-)** or **▶ (+)**, press **Set** to enter the setting.
- If you press **Stop/Reset** before **Set** is pressed, the item you have selected will not be registered.
- Press **Stop/Reset** to exit from menu system.
- If you press **Additional Functions**, the display returns to the previous screen.

■ Menu Descriptions

COMMON SETTINGS

Name	Descriptions
DEFAULT SETTINGS	Selects which mode standby display appears in the LCD when the power cord is connected, or the AUTO CLEAR function* activates.
COPY	The copy mode is selected.
FAX	The fax mode is selected.
SW AFTER AUTO CLR	Selects whether the machine switches to the mode you set in DEFAULT SETTINGS after the AUTO CLEAR function* activates.
DEFAULT MODE	The machine automatically switches to the mode you set in DEFAULT SETTINGS after the AUTO CLEAR function* activates.
CURRENT MODE	The machine does not automatically switch to the mode you set in DEFAULT SETTINGS even after the AUTO CLEAR function* activates.
VOLUME CONTROL	Adjusts the volume of the unit.
1. KEYPAD VOLUME	Adjusts the keypad volume.
ON	1 to 3 (1)
OFF	The volume is turned off.
2. ALARM VOLUME	Adjusts the alarm volume.
ON	1 to 3 (1)
OFF	The volume is turned off.
3. TX DONE TONE	Adjusts the volume of the done tone sounded when the machine has finished sending faxes.
ON	1 to 3 (1)
ERROR ONLY	1 to 3 (1)
OFF	The volume is turned off.
4. RX DONE TONE	Adjusts the volume of the done tone sounded when the machine has finished receiving faxes.
ON	1 to 3 (1)
ERROR ONLY	1 to 3 (1)
OFF	The volume is turned off.
5. PRINTING END TONE	Adjusts the volume of the done tone sounded when the machine has finished printing.
ON	1 to 3 (1)
ERROR ONLY	1 to 3 (1)
OFF	The volume is turned off.

* (→ Reference Guide)

(The factory default setting is in **bold** face.)

Name	Descriptions
6 . SCANNING END TONE ON ERROR ONLY OFF	Adjusts the volume of the done tone sounded when the machine has finished scanning. 1 to 3 (1) 1 to 3 (1) The volume is turned off.
7 . CALLING VOLUME	Adjusts the volume of the ring produced when the unit detects a voice call. 1 to 3 (2)
8 . LINE MONITOR VOL. ON OFF	Adjusts the line monitor volume. 1 to 3 (2) The volume is turned off.

(The factory default setting is in **bold** face.)



NOTE

- MP TRAY PAPERSIZE, CAS. PAPER SIZE, PRINT EXPOSURE, MP PAPERTYPE, HIGH COPY MODE, TONER SAVER MODE, PRT FEED INTERVAL and DISPLAY LANGUAGE, → Reference Guide.

COPY SETTINGS

For details, → Reference Guide.

FAX SETTINGS

Name	Descriptions
USER SETTINGS	The basic operation settings in the Fax mode can be specified.
1. TEL LINE SETTINGS	Specify the telephone line settings.
1. USER TEL NO.	Your telephone and fax number can be registered. (→ p. 2-4)
2. TEL LINE TYPE	Selects the telephone line type. (→ p. 2-7)
TOUCH TONE	The telephone line is set for touch tone dialing.
ROTARY PULSE	The telephone line is set for rotary pulse dialing.
3. TX START SPEED	Sets the transmission speed for all documents you send. 33600bps/14400bps/9600bps/7200bps/4800bps/2400bps
4. RX START SPEED	Sets the transmission speed for all documents you receive. 33600bps/14400bps/9600bps/7200bps/4800bps/2400bps
2. UNIT NAME	You can register your name (or your company name). (→ p. 2-5)
3. TX TERMINAL ID	Prints your ID (transmitting terminal ID) on each page you transmit. (→ p. 2-3)
1. TTI POSITION	OUTSIDE IMAGE: Terminal ID is printed outside the image border. INSIDE IMAGE: Terminal ID is printed inside the image border.
2. TEL NUMBER MARK	Selects the prefix for the identification header number. FAX, TEL
4. DENSITY CONTROL	Sets the density of the documents.
LIGHT	Sets for dark documents.
STANDARD	Sets for the documents of normal density.
DARK	Sets for light documents.
5. PROG 1-TOUCH KEY	Programs a fax function into the One-Touch key. The programmed fax function will be executed by directly pressing the corresponding One-Touch key. You do not need to press Function before pressing the One-Touch key.
01 - 12	Select the One-Touch key (01 to 12) in which you want to program the fax function.
USE	Uses PROGRAM 1-TOUCH KEY. The following functions can be programmed: 1. REPORT; 2. DELAYED TX; 3. FAX MONITOR; 4. MEMORY REFERENCE; 5. BOOK SENDING.
DO NOT USE	Disables PROGRAM 1-TOUCH KEY.

(The factory default setting is in **bold** face.)

Name	Descriptions
6 . OFFHOOK ALARM ON OFF	Enables/disables the offhook alarm that alerts you when the handset is not in the handset cradle. After reception, the offhook alarm sounds when the handset of extension telephone is left off the hook. No offhook alarm.
REPORT SETTINGS	Sets the report setting.
1 . TX REPORT OUTPUT NO PRINT ERROR ONLY REPORT WITH TX IMAGE ON OFF OUTPUT YES	Enables/disables automatic printing of a transmission report. No report is printed. Prints a report only when a transmission error occurs. If you select PRINT ERROR ONLY or OUTPUT YES , enables/disables printing of the first page of the fax under the report. Prints a first page only when a transmission error occurs. No first page is printed. Prints a report every time you send a document.
2 . RX REPORT OUTPUT NO PRINT ERROR ONLY OUTPUT YES	Enables/disables automatic printing of a reception report. No report is printed. Prints a report only when a reception error occurs. Prints a report every time you receive a document.
3 . ACTIVITY REPORT ON OFF	Enables/disables automatic printing of an ACTIVITY REPORT after every 20 transactions. Prints the ACTIVITY REPORT . No ACTIVITY REPORT is printed.
TX SETTINGS	Sets the transmission functions.
1 . ECM TX ON OFF	ECM (error correction mode) transmission is turned on or off. All transmissions are conducted with ECM if the other party's fax supports ECM. ECM is turned off.
2 . PAUSE TIME	Sets the length of the pause you insert into a dialing sequence. 1 to 15 SEC (2 SEC)

(The factory default setting is in **bold** face.)

Name	Descriptions
3 .AUTO REDIAL	Sets whether to perform automatic redial when the other line is busy or no answer.
ON	Customizes the redial operation.
1 .REDIAL TIMES	Sets the number of retries. 1 to 10 TIMES (2 TIMES)
2 .REDIAL INTERVAL	Sets period of time between redialings. 2 to 99 MIN. (2 MIN.)
3 .TX ERROR RESEND	Redialing is attempted when a transmission error occurred.
ON	RESEND TX FROM: Sets the number of pages to be sent when redialing is attempted. ERROR & 1ST PAGE , ERROR PAGE, ALL PAGES
OFF	Redialing is not attempted when a transmission error has occurred.
OFF	After the first attempt at dialing fails, redialing is not attempted.
4 .ERASE FAILED TX	Sets the ERASE FAILED TX function.
ON	The document is deleted from the memory stored in the machine if a transmission error has occurred.
OFF	The document is not deleted from the memory stored in the machine even if a transmission error has occurred.
5 .TIME OUT	Enables/disables automatic scanning of documents after the fax number is entered by using speed dialing.
ON	Scanning begins automatically in 5 or 10 seconds after you enter the phone number.
OFF	Press Start to scan document. Otherwise, the machine will return to standby mode after 2 minutes while the AUTO CLEAR function activates.
RX SETTINGS	Sets the reception functions.
1 .ECM RX	ECM (error correction mode) receiving is turned on or off.
ON	All receptions are conducted with ECM if the other party's fax supports ECM.
OFF	ECM is turned off.
2 .FAX/TEL OPT.SET	When FaxTel has been set, the optional settings are available.
1 .RING START TIME	Sets the duration that the machine listens for a fax tone before starting to ring. 0 to 30 SEC (8 SEC)
2 .F/T RING TIME	Sets the length of time the machine rings to alert you of an incoming call. 15 to 300 SEC (15 SEC)
3 .F/T SWITCH ACTION	Selects the action taken after the F/T RING TIME expires.
RECEIVE	The machine switches to fax receive mode automatically at that point and starts to receive the document.
DISCONNECT	The machine disconnects the call.

(The factory default setting is in **bold** face.)

Name	Descriptions
3. DRPD: SELECT FAX NORMAL RING DOUBLE RING SHORT-SHORT-LONG SHORT-LONG-SHORT OTHER RING TYPE	Select a ring pattern when the machine receives faxes. (→ p. 5-5) Ring type of normal telephone line. Two short rings at regular intervals. Short-short-long at regular intervals. Short-long-short at regular intervals. Patterns other than those described above.
4. INCOMING RING OFF ON RING COUNT	When the machine is set to FaxOnly and Fax/Te1, set whether the machine rings when it receives a call. The machine does not ring when it receives a fax. (In energy saver mode, the fax may ring one or two times.) The machine rings when it receives a fax if the handset or a telephone is connected. Sets the number of incoming rings before the machine answers. 1 to 99 TIMES (2 TIMES)
5. MAN/AUTO SWITCH OFF ON	Sets the machine to switch to document receive mode after ringing for a specified length of time in the manual receive mode. The machine keeps ringing until someone answers the call manually with the handset or a connected extension telephone. F/T RING TIME: Sets the length of time to elapse before the machine switches to the document receiving. 5 to 99 SEC (15 SEC)
6. REMOTE RX ON REMOTE RX ID OFF	Receives from a remote telephone with preset setting. Remote receiving is turned on. You can dial a number code on the remote extension to start receiving a document. A combination of two characters using 0 to 9, * and # (25) is possible. Remote receiving is turned off.
PRINTER SETTINGS	Sets the print functions.
1. RX REDUCTION ON 1. RX REDUCTION 2. SELECT REDUCE DIR OFF	Receives images at a reduced size. Turn on image reduction. AUTO SELECTION: Reducing size is set to auto. FIXED REDUCTION: Reducing size is preset. 97%, 95%, 90% , 75% VERTICAL ONLY: Reduction is performed in the vertical direction only. HORIZ & VERTICAL: Reduction is performed in the horizontal and vertical direction. Image reduction is turned off.

(The factory default setting is in **bold** face.)

Name	Descriptions
2.TONER SUPPLY LOW KEEP PRINTING RX TO MEMORY	Allows you to set whether the machine stores the document in memory when the toner supply is low or ignores the warning and keeps printing until the document is completely printed. This setting is convenient if a new cartridge is not at hand. The keep printing function is turned on. With this setting, the machine does not store documents in memory if the toner has run out. Re-set to RX TO MEMORY after replacing the cartridge with a new one. The machine receives the document in memory.
SYSTEM SETTINGS	Sets the functions of FAX DEFAULT and LOCK PHONE.
----- 1.FAX DEFAULT 1.RESOLUTION OFF STANDARD FINE PHOTO SUPER FINE ULTRA FINE 2.BOOK TX SCAN SIZE	Sets the FAX DEFAULT functions. Sets the fax resolution. The setting of resolution set using FAX Resolution remains even after the AUTO CLEAR function activates. Suitable for most text-only documents. Suitable for fine-print documents. Suitable for documents that contain photographs. Suitable for documents that contain fine print and images (the resolution is four times that of STANDARD). Suitable for documents that contain fine print and images (the resolution is eight times that of STANDARD). When you select SHEET: Before sending a fax, you must press Book Sending and specify the scanning size of either LGL or LTR. When you select LGL or LTR: The document will be scanned in the size you selected, either LGL or LTR. SHEET , LGL, LTR
----- 2.LOCK PHONE OFF ON	Sets the LOCK PHONE functions. The telephone or fax transmission can be used normally. The telephone transmission cannot be used. The telephone reception and fax transmission/reception can be used.

(The factory default setting is in **bold** face.)

ADD. REGISTRATION

Name	Descriptions
1-TOUCH SPD DIAL	Registers the informations on One-Touch Speed Dialing. (→ p. 3-2)
----- 1-TOUCH SPD DIAL	Selects a one-touch speed dialing key.
1. TEL NUMBER ENTRY	Registers the other party's telephone number.
2. NAME	Registers the other party's name.
3. OPTIONAL SETTING	The transmission time and settings including the registration of password and subaddress can be specified.
ON	The optional settings can be set.
1. TX TIME SETTING	5 settings of the transmission time can be specified.
	Setting procedure
	1 Select the time setting number (1 to 5) by repeatedly pressing Set , and press Set again.
	2 Enter the hour and minute for the transmission time using the numeric keys, then press Set . (Enter 0 before the 1-digit hour or minute. For example, enter "0905" for 9:05 am.)
	• If you make a mistake while entering, press Function and Clear , then enter the correct time.
	Sending procedure
	1 Load the document face down in the ADF or on the platen glass.
	2 Press the one-touch speed dialing key on which the transmission time is set. The document is scanned and stored in memory.
	The machine transmits the document at the transmission time. If you have set more than 2 transmission time settings, the document will be transmitted at the preset time closest to the time that the document has been scanned.
	Once you set the transmission time, the machine will transmit the document at the same time on every day.
	However, you cannot use the one-touch speed dialing key to send the document as usual, and cannot send the document any time unless you cancel the transmission time setting.
	To cancel the setting, press Set in TX TIME SETTING to select the preset time, and press Set again. Then, press Function and Clear , and press Set . The preset time is deleted.
	If you have set more than 2 transmission time settings, repeat this procedure to delete all the preset times. Or, when OFF is selected in OPTIONAL SETTING, TX TIME SETTING and TX TYPE are canceled. You do not need to delete all the preset times.
2. TX TYPE	REGULAR TX: For a normal transmission.
	SUBADDRESS TX: For a subaddress transmission.
	Registers passwords and subaddresses.
	POLLING RX: For a polling reception. Registers passwords and subaddresses.
OFF	No setting.

(The factory default setting is in **bold** face.)

Name	Descriptions
CODED SPD DIAL	Registers the information on Coded Speed Dialing. (→ p. 3-4) To register them, perform the same procedure with that of 1-TOUCH SPD DIAL.
GROUP DIAL	Registers the information on Group Dialing. (→ p. 3-7)
1.TEL NUMBER ENTRY	Registers the other party's telephone numbers by specifying the One-Touch Speed Dialing keys or Coded Speed Dialing codes.
2.NAME	Registers the group's name.
3.TX TIME SETTING	Sets the transmission time. 5 settings of the transmission time can be specified. To set them, perform the same procedure with that of 1-TOUCH SPD DIAL.

TIMER SETTINGS

For details, → Reference Guide.

ADJUST/CLEAN

For details, → Reference Guide.

PRINT LISTS

Name	Descriptions
USER DATA	Prints out a list of items set or registered in the Additional Functions.
SPEED DIAL LIST	Prints the list of the fax/telephone numbers registered for the One-Touch Speed Dialing keys, Coded Speed Dialing codes or Group Dialing.
1.1-TOUCH LIST	Prints the 1-TOUCH LIST.
1.NO SORT	The printout of the list is not sorted.
2.SORT	The printout of the list is sorted.
2.CODED DIAL LIST	Prints the CODED DIAL LIST.
1.NO SORT	The printout of the list is not sorted.
2.SORT	The printout of the list is sorted.
3.1-TOUCH (DETAIL)	Prints the details of the 1-TOUCH LIST.
1.NO SORT	The printout of the list is not sorted.
2.SORT	The printout of the list is sorted.
4.CODED (DETAIL)	Prints the details of the CODED DIAL LIST.
1.NO SORT	The printout of the list is not sorted.
2.SORT	The printout of the list is sorted.
5.GROUP DIAL LIST	Prints the list of the Group Dialing.
CANCEL REPORT	Cancels printout of the report.

Appendix:

Specifications

■ Facsimile

■ Applicable Line

Public Switched Telephone Network (PSTN)

■ Compatibility

G3

■ Data Compressing System

MH, MR, MMR, JBIG

■ Modem Speed

33.6/31.2/28.8/26.4/24/21.6/19.2/16.8/14.4/12/
9.6/7.2/4.8/2.4 Kbps
Automatic fallback

■ Transmission Speed

Approx. 3 seconds/page* at 33.6 Kbps,
ECM-MMR, transmitting from memory
* Based on ITU-T No. 1 Chart, standard mode.

■ Scanning Image Processing

- UHQ™ (Ultra High Quality) image enhancement

■ Transmission/Reception Memory

Transmission: Maximum approx. 255 pages*
Reception: Maximum approx. 255 pages*
* Based on ITU-T No. 1 Chart, standard mode.

■ Fax Scanning Speed

Approx. 3.2 seconds/page*
* Based on standard mode.

■ Fax Resolution

STANDARD: 203 pels/in. × 98 lines/in.
(8 pels/mm × 3.85 lines/mm)
FINE: 203 pels/in. × 196 lines/in.
(8 pels/mm × 7.7 lines/mm)
SUPER FINE: 203 pels/in. × 392 lines/in.
(8 pels/mm × 15.4 lines/mm)
ULTRA FINE: 406 pels/in. × 392 lines/in.
(16 pels/mm × 15.4 lines/mm)

■ Dialing

- Automatic dialing
 - One-touch speed dialing (12 destinations)
 - Coded speed dialing (100 destinations)
 - Group dialing (Max. 111 destinations)
 - Directory dialing (with Directory key)
- Regular dialing (with numeric keys)
- Automatic redialing
- Manual redialing (with Redial/Pause key)

■ Networking

- Sequential broadcast (Max. 122 destinations)
- Automatic reception
- Automatic Fax/Tel switchover
- Remote reception by telephone (Default ID: 25)
- Non-ring reception
- ECM deactivation
- DRPD (Distinctive Ring Pattern Detection)
- ACTIVITY REPORT (after every 20 transactions)
- Non-delivery report
- TTI (Transmit Terminal Identification)

■ Telephone

■ Connection

Telephone/answering machine (CNG detecting signal)/data modem

Index

- ◀ (-) key1-1
- ▶ (+) key1-1
- + key1-2
- 1-TOUCH
 - SPD DIAL setting9-9
- 1-TOUCH LIST
 - description7-1
 - printing3-9
 - sample3-9, 3-10

- A**
- Accessing, menus9-1
- ACTIVITY REPORT
 - description7-1, 7-2
 - printing7-2
 - sample7-2
 - setting9-5
- Additional Functions
 - accessing9-1
 - key1-1
 - understanding9-1
- Alarm indicator1-1
- ALARM VOLUME setting9-2
- AnsMode, description5-1
- Answering machine
 - connecting1-4
- AUTO REDIAL settings9-6
- Automatic redialing
 - canceling4-8
 - description4-8

- B**
- Book Sending key1-2
- BOOK TX SCAN SIZE setting9-8
- Broadcasting, sequential4-9
- BUSY/NO SIGNAL8-2

- C**
- CANCEL REPORT setting9-10
- Canceling
 - automatic redialing4-8
 - manual redialing4-8
 - printing lists3-11
 - receiving5-9
 - sending4-7
- CHANGE DOCUMENT message8-1
- Clear key1-2
- Coded Dial key1-2
- CODED DIAL LIST
 - description7-1
 - printing3-9
 - sample3-10, 3-11
- CODED SPD DIAL setting9-10
- Coded speed dialing
 - changing, deleting3-5
 - description3-1
 - registering numbers for3-4
 - using4-3
- Confirming
 - sending reservation4-12
 - transmission status4-12
- Connecting
 - answering machine1-4
 - external device1-4
 - telephone1-3, 1-4
 - telephone line1-3
- COPY key1-1
- CURRENT MODE setting9-2
- Customer support1-1

- D**
- Date, entering2-4
- DEFAULT MODE setting9-2
- DEFAULT SETTINGS9-2
- Delayed sending4-11
- Delayed Transmission key1-2, 4-11
- Delete key1-2
- Deleting document from memory4-16
- DENSITY CONTROL settings9-4
- Device connections1-4

Dialing	
coded speed	3-1, 3-4, 3-5, 3-6, 4-3
group	3-1, 3-7, 3-8, 4-4
methods	4-2
one-touch speed	3-1, 3-2, 3-3, 4-3
overseas number	6-1
regular	4-2
speed (See Speed dialing)	
switching temporarily to tone	6-2
through switchboard	6-1
with pauses	6-1
Directory key	1-2
Document	
in memory	4-13
printing document in memory	4-15
printing list of documents in memory	4-13
DOCUMENT MEMORY LIST	
description	7-1
printing	4-13
sample	4-13
DOCUMENT TOO LONG message	8-1
DOUBLE RING setting	9-7
DRPD	
description	5-1, 5-2
setting options for	5-5
settings	9-7
types of ring patterns	5-5
E	
ECM	
RX setting	9-6
TX setting	9-5
Energy Saver key	1-1
ERASE FAILED TX setting	9-6
External device, connecting	1-4
F	
F/T RING TIME setting	9-6
F/T SWITCH ACTION setting	5-4, 9-6
FAX key	1-1
FAX DEFAULT settings	9-8
Fax Monitor key	1-2
FaxOnly	
description	5-1, 5-2
device connections	1-4
FAX Resolution key	1-2
FaxTel	
description	5-1, 5-2
device connections	1-4
setting options for	5-3
FAX/TEL OPT. SET settings	9-6
FINE	
description	4-1
setting	4-1, 9-8
Function key	1-2
G	
GROUP DIAL LIST	
description	7-1
printing	3-9
sample	3-11
Group dialing	
creating groups	3-7
description	3-1
using	4-4
H	
HANG UP PHONE message	8-1
I	
In Use/Memory indicator	1-1
INCOMING RING settings	9-7
INSIDE IMAGE setting	9-4
J	
Jack	1-3
K	
KEEP PRINTING setting	9-8
KEYPAD VOLUME setting	9-2
Keys (See also individual key names)	
numeric	1-1
one-touch speed dialing	1-2
L	
LCD	
description	1-1
messages (See also individual message names)	
messages, descriptions	8-1
Letters, entering	2-2
LINE MONITOR VOL. setting	9-3
List (See individual list names)	

LIST setting		NO TEL # message	8-1
1-TOUCH	9-10	NORMAL RING setting	9-7
CODED DIAL	9-10	Numbers, entering	2-2
GROUP DIAL	9-10	Numeric keys	1-1
SPEED DIAL	9-10		
LOCK PHONE setting	9-8	O	
M		OFFHOOK ALARM setting	9-5
MAN/AUTO SWITCH settings	9-7	One-touch speed dialing	
Manual		changing, deleting	3-3
description	5-1, 5-2	description	3-1
device connections	1-4	keys	1-2
receiving in	5-6	registering numbers for	3-2
Manual redialing		using	4-3
canceling	4-8	Operation panel	
MEM IN USE nn % message	8-1	registering information via	2-1
Memory		OPTIONAL SETTING	
deleting document from	4-16	for 1-TOUCH SPD DIAL	9-9
documents in	4-13	OTHER RING TYPE setting	9-7
printing document in	4-15	OUTSIDE IMAGE setting	9-4
printing list of documents in	4-13	Overseas number, dialing	6-1
receiving when problem occurs	5-9		
sending (See Memory sending)		P	
MEMORY CLEAR REPORT		PAUSE TIME setting	9-5
description	8-5	Pauses, dialing with	6-1
sample	8-5	PHOTO	
MEMORY FULL message	8-1	description	4-1
Memory Reference key	1-2	setting	4-1, 9-8
Memory sending		Polling	5-8, 5-9
canceling	4-7	Power	
using, ADF	4-5	cut	8-5
using, platen glass	4-6	PRINTER SETTINGS	9-7
Menu descriptions	9-2	Printing	
Messages, LCD (See also individual message names)		1-TOUCH LIST	3-9
descriptions	8-1	ACTIVITY REPORT	7-2
Mistake, correcting	2-2	CODED DIAL LIST	3-9
MULTI TX/RX REPORT		document in memory	4-15
description	7-4	DOCUMENT MEMORY LIST	4-13
sample	7-4	GROUP DIAL LIST	3-9
N		list of documents in memory	4-13
NAME setting		speed dialing lists	3-9
for 1-TOUCH SPD DIAL	9-9	USER'S DATA LIST	2-6
for GROUP DIAL	9-10	PRINTING END TONE setting	9-2

Problems	
cannot solve	8-6
faxing	8-2
receiving.....	8-3
receiving in memory when	5-9
sending.....	8-2
telephone.....	8-5
PROG 1-TOUCH KEY settings.....	9-4
Q	
Quality, adjusting.....	4-1
R	
Receive Mode key	1-2
Receive Mode	
device connections.....	1-4
settings	5-2
RECEIVED IN MEMORY message.....	8-1
Receiving (See also individual receive modes)	
canceling	5-9
in memory when problem occurs	5-9
manually.....	5-6
methods	5-1, 5-2
problems.....	8-3
while performing other tasks	5-9
Redial/Pause key	1-2
REDIAL INTERVAL setting.....	9-6
REDIAL TIMES setting.....	9-6
Redialing	
automatic.....	4-8
manual.....	4-8
Registering	
coded speed dialing	3-4
one-touch speed dialing	3-2
password and subaddress.....	3-12, 3-13, 5-7, 5-8
sender information	2-3 to 2-5
via operation panel.....	2-1
Regular dialing	4-2
REMOTE RX ID setting	9-7
REMOTE RX settings.....	9-7
Report (See also individual report names)	
settings	9-5
Report key	1-2
REPORT SETTINGS	9-5
REPORT WITH TX IMAGE setting	9-5
Resolution, setting scanning.....	4-1
RESOLUTION settings.....	9-8
RING COUNT setting.....	9-7
RING START TIME setting.....	9-6
ROTARY PULSE setting.....	2-7, 9-4
RX (Reception)	
report.....	7-1
SETTINGS.....	9-6
RX DONE TONE setting	9-2
RX REDUCTION settings	9-7
RX REPORT	
description	7-1, 7-4
sample	7-4
settings	9-5
RX START SPEED setting	9-4
RX TO MEMORY setting.....	9-8
S	
Scanning	
resolution, setting.....	4-1
SCANNING END TONE setting.....	9-3
SELECT REDUCE DIR setting.....	9-7
Sender information	
description.....	2-3
printing list to check	2-6
registering.....	2-4, 2-5
Sending	
canceling	4-7
memory	4-5
methods	4-5
preparing	4-1
problems.....	8-2
sequential broadcasting	4-9, 4-10
setting scanning resolution	4-1
timer (See Delayed sending)	
to more than one destination	4-9, 4-10
using coded speed dialing.....	4-3
using group dialing	4-4
using one-touch speed dialing	4-3
Set key	1-1
Setting	
resolution	4-1
Settings, list of.....	9-10

SHORT-LONG-SHORT setting	9-7	TTI POSITION setting	9-4
SHORT-SHORT-LONG setting	9-7	TX DONE TONE setting	9-2
Space key	1-2	TX ERROR RESEND setting	9-6
Speed dialing		TX REPORT	
coded	3-4, 3-5, 3-6, 4-3	description	7-1, 7-3
description	3-1	sample	7-3
group dialing	3-7, 3-8, 4-4	settings	9-5
lists	3-9, 3-10, 3-11	TX START SPEED setting	9-4
methods	3-1	TX TERMINAL ID setting	9-4
one-touch	3-2, 3-3, 4-3	TX TIME SETTING	
STANDARD		for 1-TOUCH SPD DIAL	9-9
description	4-1	for GROUP DIAL	9-10
setting	4-1, 9-8	TX (Transmission) SETTINGS	9-5
Standby display, fax mode	1-3	TX TYPE settings	9-9
Start key	1-1	TX/RX NO. nnnn message	8-1
Stop/Reset key	1-1	Type conventions, this guide	ix
SUPER FINE		U	
description	4-1	ULTRA FINE	
setting	4-1, 9-8	description	4-1
Support		setting	4-1, 9-8
customer	1-1	UNIT NAME setting	9-4
SW AFTER AUTO CLR setting	9-2	USER	
Symbols, entering	2-2	DATA setting	9-10
SYSTEM SETTINGS	9-8	SETTINGS	9-4
T		USER TEL NO. setting	9-4
TEL LINE SETTINGS	9-4	USER'S DATA LIST	
TEL LINE TYPE settings	9-4	description	7-1
TEL NUMBER		printing	2-6
ENTRY setting for 1-TOUCH SPD DIAL	9-9	sample	2-6
ENTRY setting for GROUP DIAL	9-10	V	
TEL NUMBER MARK setting	9-4	VOLUME CONTROL setting	9-2
Telephone			
connecting	1-3, 1-4		
problems	8-5		
Telephone line			
connecting	1-3		
setting type	2-7		
Time, entering	2-4		
TIME OUT setting	9-6		
Timer sending (See Delayed sending)			
TONE (✳) key	1-1		
Tone dialing, switching to	6-2		
TONER SUPPLY LOW setting	9-8		
TOUCH TONE setting	2-7, 9-4		



CANON INC.

30-2, Shimomaruko 3-chome, Ohta-ku, Tokyo 146-8501, Japan

CANON U.S.A., INC.

One Canon Plaza, Lake Success, NY 11042, U.S.A.

CANON CANADA INC.

6390 Dixie Road Mississauga, Ontario L5T 1P7, Canada

CANON EUROPA N.V.

Bovenkerkerweg 59-61 P.O. Box 2262, 1180 EG Amstelveen, The Netherlands

CANON FRANCE S.A.

17, quai du President Paul Doumer 92414 Courbevoie Cedex, France

CANON COMMUNICATION & IMAGE FRANCE S.A.

(Pour les utilisateurs de l'imprimante laser uniquement)

102, avenue du Général de Gaulle 92257 La Garenne-Colombes Cedex, France

CANON (U.K.) LTD.

Woodhatch, Reigate, Surrey, RH2 8BF, United Kingdom

CANON DEUTSCHLAND GmbH

Europark Fichtenhain A10, 47807 Krefeld, Germany

CANON ITALIA S.p.A.

Palazzo L Strada 6 20089 Milanofiori Rozzano (MI) Italy

CANON LATIN AMERICA, INC.

703 Waterford Way Suite 400 Miami, Florida 33126 U.S.A.

CANON AUSTRALIA PTY. LTD

1 Thomas Holt Drive, North Ryde, Sydney, N.S.W. 2113, Australia

CANON SINGAPORE PTE. LTD.

79 Anson Road #09-01/06, Singapore 079906

CANON HONGKONG CO., LTD

9/F, The Hong Kong Club Building, 3A Chater Road, Central, Hong Kong

120V