

BUNN[®]

SINGLE TF DBC W/SMART FUNNEL[®]

S/N SNG0033000 & UP



INSTALLATION & OPERATING MANUAL

BUNN-O-MATIC CORPORATION

POST OFFICE BOX 3227

SPRINGFIELD, ILLINOIS 62708-3227

PHONE: (217) 529-6601 FAX: (217) 529-6644

To ensure you have the latest revision of the manual or to obtain the illustrated parts catalog, please visit the Bunn-O-Matic website, at www.bunn.com. This is absolutely FREE, and the quickest way to obtain the latest catalog and manual updates. Contact Bunn-O-Matic Corporation at 1-800-286-6070 to obtain a paper copy of the required Illustrated Parts Catalog mailed via U.S. Postal Service.

BUNN-O-MATIC COMMERCIAL PRODUCT WARRANTY

Bunn-O-Matic Corp. ("BUNN") warrants equipment manufactured by it as follows:

- 1) All equipment other than as specified below: 2 years parts and 1 year labor.
- 2) Electronic circuit and/or control boards: parts and labor for 3 years.
- 3) Compressors on refrigeration equipment: 5 years parts and 1 year labor.
- 4) Grinding burrs on coffee grinding equipment to grind coffee to meet original factory screen sieve analysis: parts and labor for 3 years or 30,000 pounds of coffee, whichever comes first.

These warranty periods run from the date of installation BUNN warrants that the equipment manufactured by it will be commercially free of defects in material and workmanship existing at the time of manufacture and appearing within the applicable warranty period. This warranty does not apply to any equipment, component or part that was not manufactured by BUNN or that, in BUNN's judgment, has been affected by misuse, neglect, alteration, improper installation or operation, improper maintenance or repair, damage or casualty. This warranty is conditioned on the Buyer 1) giving BUNN prompt notice of any claim to be made under this warranty by telephone at (217) 529-6601 or by writing to Post Office Box 3227, Springfield, Illinois 62708-3227; 2) if requested by BUNN, shipping the defective equipment prepaid to an authorized BUNN service location; and 3) receiving prior authorization from BUNN that the defective equipment is under warranty.

THE FOREGOING WARRANTY IS EXCLUSIVE AND IS IN LIEU OF ANY OTHER WARRANTY, WRITTEN OR ORAL, EXPRESS OR IMPLIED, INCLUDING, BUT NOT LIMITED TO, ANY IMPLIED WARRANTY OF EITHER MERCHANTABILITY OR FITNESS FOR A PARTICULAR PURPOSE. The agents, dealers or employees of BUNN are not authorized to make modifications to this warranty or to make additional warranties that are binding on BUNN. Accordingly, statements by such individuals, whether oral or written, do not constitute warranties and should not be relied upon.

If BUNN determines in its sole discretion that the equipment does not conform to the warranty, BUNN, at its exclusive option while the equipment is under warranty, shall either 1) provide at no charge replacement parts and/or labor (during the applicable parts and labor warranty periods specified above) to repair the defective components, provided that this repair is done by a BUNN Authorized Service Representative; or 2) shall replace the equipment or refund the purchase price for the equipment.

THE BUYER'S REMEDY AGAINST BUNN FOR THE BREACH OF ANY OBLIGATION ARISING OUT OF THE SALE OF THIS EQUIPMENT, WHETHER DERIVED FROM WARRANTY OR OTHERWISE, SHALL BE LIMITED, AT BUNN'S SOLE OPTION AS SPECIFIED HEREIN, TO REPAIR, REPLACEMENT OR REFUND.

In no event shall BUNN be liable for any other damage or loss, including, but not limited to, lost profits, lost sales, loss of use of equipment, claims of Buyer's customers, cost of capital, cost of down time, cost of substitute equipment, facilities or services, or any other special, incidental or consequential damages.

BrewWISE, BUNN Gourmet Ice, BUNN Pour-O-Matic, BUNN, Bunn-OMatic, Bunn-O-Matic, BUNNlink, BUNNserve, BUNN Espresso, DBC, Dr. Brew, Dual, EasyClear, EasyGard, Easy Pour, FlavorGard, Gourmet Ice, Gourmet Juice, High Intensity, IMIX, Infusion Series, Legendary for Quality, The Mark of Quality in Beverage Equipment Worldwide, My Café, PowerLogic, Safety-Fresh, Single, Smart Funnel, Smart Hopper, Soft Heat, SplashGard, System III, ThermoFresh, 392, AXIOM, Beverage Profit Calculator, Beverage Bar Creator, BrewLOGIC, BrewMETER, BrewWIZARD, BUNNSERVE, BUNNsource, Coffee At Its Best, Cool Froth, Digital Brewer Control, Intellisteam, Nothing Brews Like a BUNN, Pouring Profits, Pulse Wave, Quality Beverage Equipment Worldwide, Scale-Pro, Signature Series, Silver Series, Smart Heat, SmartWAVE, Tea At Its Best, The Horizontal Red Line, Titan, Ultra, are either trademarks or registered trademarks of Bunn-O-Matic Corporation.

TABLE OF CONTENTS

User Notices	4
Electrical	5
Plumbing Requirements	7
Operating Controls	8
Initial Setup	9
Coffee Brewing	9
Cleaning	10
Glossary	11
PROGRAMMING	12
Programming Switches	12
Programming the Brewer	13
PROGRAM FUNCTIONS (LEVEL 1) Brew Lockout	13
PROGRAM FUNCTIONS (LEVEL 2)	14
PROGRAM FUNCTIONS (FLOW)	15
Set Units (Setting units of measure)	18
Set New Recipe (using a Smart Funnel and G92T DBC or MHG Grinder)	19
Set Brew Volumes	19
Set By-Pass Percentages	20
Set Pulse Brew Times	20
Set Drip Times	20
Set New Recipe (using a Recipe Card)	18
Set New Recipe (no Smart Funnel nor G9-2T DBC Grinder)	19
Review Recipes/Modify Recipes/Set up No Name Coffee	20
Set Brew Volumes	24
Set Bypass Percentages	25
Set Pulse Brew Times	26
Easy Pulse	28
Enter Times	29
Set Preinfusion Times	30
Set Drip Times	31
Assign Recipes	32
Enable Ads	32
Set Temp (Brewing Temperature)	33
Set Ready (Ready Temperature)	33
Refill (Adjust Sensitivity)	33
Spray Oz/M (Read sprayhead flow rate)	34
Bypass Oz/M (Read bypass flow rate)	34
Calibrate Flow	34
Calibrate Sprayhead Flow	34
Calibrate Bypass Flow	35
Brew Counters (View/Reset)	36
Funnel Detect	36
Service Tools	37
Test Outputs (Components)	37
Test Switches	38
Test Frequency	38
Factory Defaults (Reset)	39
Troubleshooting	40
Schematic (Wiring Diagram)	51

USER NOTICES

The notices on this brewer should be kept in good condition. Replace unreadable or damaged labels.



00658.0000



03408.0004



03409.0004



20201.5600

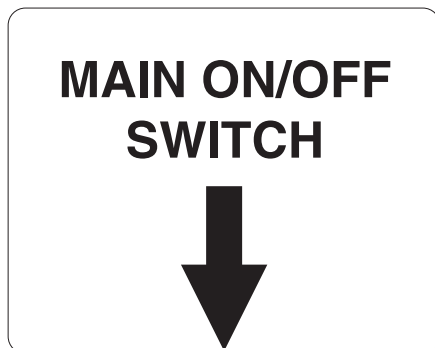

39803.0000



00824.0000



00824.0001

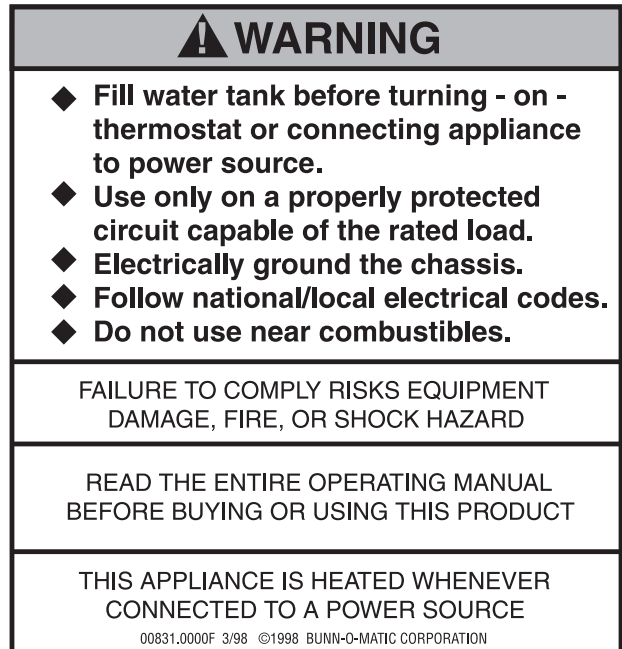

00831.0000

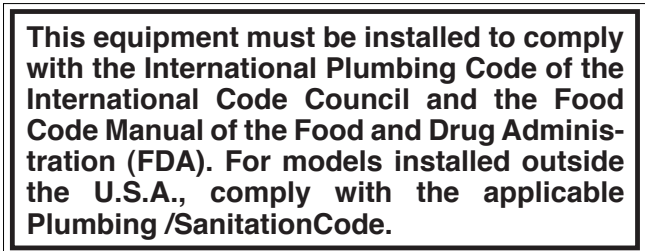

00656.0000

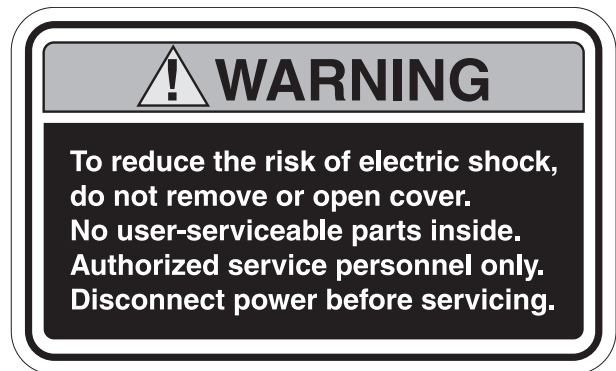

37881.0000

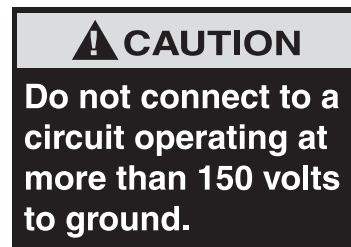

27508.0000

USER NOTICES (cont.)

⚠ WARNING

To reduce the risk of electric shock, do not remove or open cover. No user-serviceable parts inside.

Authorized service personnel only. Disconnect power before servicing.

37881.0002

ELECTRICAL REQUIREMENTS (Models with power cord)

WARNING - The brewer must be disconnected from the power source until specified in *Initial Set-Up*.

Refer to Data Plate on the Brewer, and local/national electrical codes to determine circuit requirements.

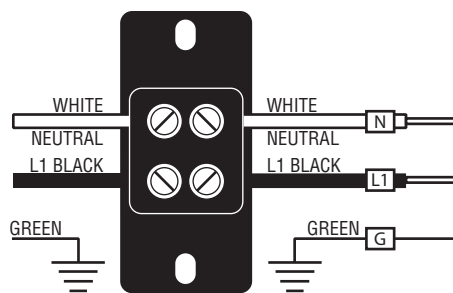

120 volt ac single phase,
60 Hz models

Note: This electrical service consists of 2 current carrying conductors (Neutral and L1) and a separate conductor for earth ground.

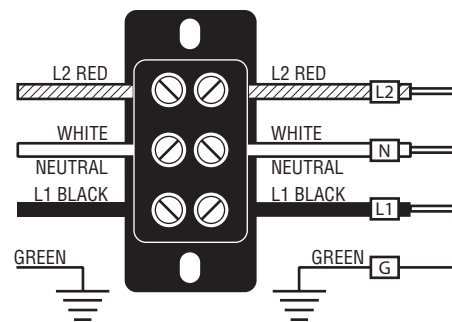

120/208 and 120/240 volt ac
single phase, 60 Hz models

Note: This electrical service consists of 3 current carrying conductors (Neutral, L1 and L2) and a separate conductor for earth ground.

ELECTRICAL HOOK-UP

WARNING – If the power cord is ever damaged, it must be replaced by the manufacturer or authorized service personnel with a special cord available from the manufacturer or its authorized service personnel in order to avoid a hazard. Improper electrical installation will damage electronic components. **Damage caused by incorrect electrical connections is not covered by warranty.**

1. An electrician must provide electrical service.
2. Using a voltmeter, check the voltage and color coding of each conductor at the electrical source.
NOTE - The brewer is shipped without a plug on the power cord. Qualified service personnel must select and install the proper UL listed grounding type attachment plug specified on the rear of the brewer.
3. Install the specified plug on the attached power cord.
4. Remove the front panel beneath the sprayheads to gain access to the terminal block.
5. Connect the brewer to the power source and verify the voltage at the terminal block before proceeding.
6. If plumbing is to be hooked up later be sure the brewer is disconnected from the power source. If plumbing has been hooked up, the brewer is ready for *Initial Set-Up*.

WARNING – Electrical connections must be made as specified above. Failure to follow these instructions can result in personal injury, property or equipment damage.

ELECTRICAL REQUIREMENTS (Models without power cord)

WARNING - The brewer must be disconnected from the power source until specified in *Initial Set-Up*.

Refer to Data Plate on the Brewer, and local/national electrical codes to determine circuit requirements.

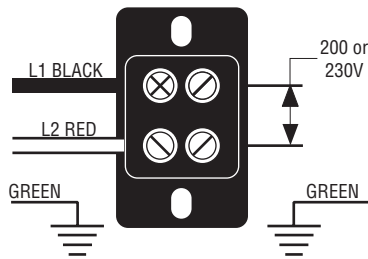

200 and 230 volt ac
single phase, 60 Hz models

Note: This electrical service consists of 2 current carrying conductors (L1 and L2) and a separate conductor for earth ground.

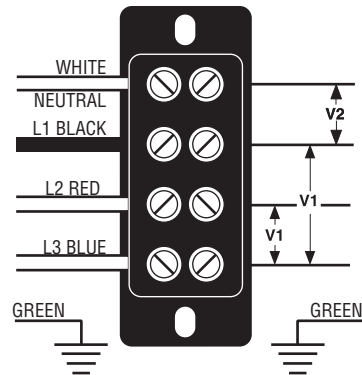

120/208 and 120/240 volt ac
three phase, 50 Hz models

Note: This electrical service consists of 4 current carrying conductors (Neutral, L1, L2 and L3) and a separate conductor for earth ground.

SYSTEM VOLTAGE	V1	V2
208	208	120
240	240	120

L1, L2, L3, are the 3 phases

V1 = Phase to phase voltage, between any 2 phases.

V2 = Phase to neutral voltage, L1 to neutral must be 120V.

CAUTION: Do not connect L1 to a circuit operating at more than 150 volts to ground.

ELECTRICAL HOOK-UP

CAUTION – Improper electrical installation will damage electronic components. **Damage caused by incorrect electrical connections is not covered by warranty.**

1. An electrician must provide electrical service as specified.
2. Using a voltmeter, check the voltage and color coding of each conductor at the electrical source.
3. Remove the front panel beneath the sprayheads to gain access to the terminal block.
4. Feed the cord through the strain relief and connect it to the terminal block.
5. Connect the brewer to the power source and verify the voltage at the terminal block before proceeding. Replace the front panel.
6. If plumbing is to be hooked up later be sure the brewer is disconnected from the power source. If plumbing has been hooked up, the brewer is ready for *Initial Set-Up*.

WARNING – Electrical connections must be made as specified above. Failure to follow these instructions can result in personal injury, property or equipment damage.

CE REQUIREMENTS

- This appliance must be installed in locations where it can be overseen by trained personnel.
- For proper operation, this appliance must be installed where the temperature is between 0°C to 35°C.
- Appliance shall not be tilted more than 10° for safe operation.
- An electrician must provide electrical service as specified in conformance with all local and national codes
- This appliance must not be cleaned by water jet
- This appliance is not intended for use by persons (including children) with reduced physical, sensory or mental capabilities, or lack of experience and knowledge, unless they have been given instructions concerning use of this appliance by a person responsible for its safety.
- If the power cord is ever damaged, it must be replaced by the manufacturer or authorized service personnel with a special cord available from the manufacturer or its authorized service personnel in order to avoid a hazard.

PLUMBING REQUIREMENTS

This brewer must be connected to a cold water system with operating pressure between 20 and 90 psi (138 and 620 kPa) from a ½" or larger supply line. A shut-off valve should be installed in the line before the brewer. Install a regulator in the line when pressure is greater than 90 psi (620 kPa) to reduce it to 50 psi (345 kPa). The water inlet fitting is ¾" flare or female quick connect.

NOTE – Bunn-O-Matic recommends ¾" copper tubing for all installations from the ½" water supply line. A tight coil of copper tubing in the water line will facilitate moving the brewer to clean the counter top. Bunn-O-Matic does not recommend the use of a saddle valve to install the brewer. The size and shape of the hole made in the supply line by this type of device may restrict water flow.

This equipment must be installed to comply with the International Plumbing Code of the International Code Council and the Food Code Manual of the Food and Drug Administration (FDA). For models installed outside the U.S.A., you must comply with the applicable Plumbing/Sanitation Code for your area.

PLUMBING HOOK-UP

1. Flush the water line and securely attach it to the flare fitting located on bottom of brewer.
2. Turn on the water supply.

OPERATING CONTROLS^f

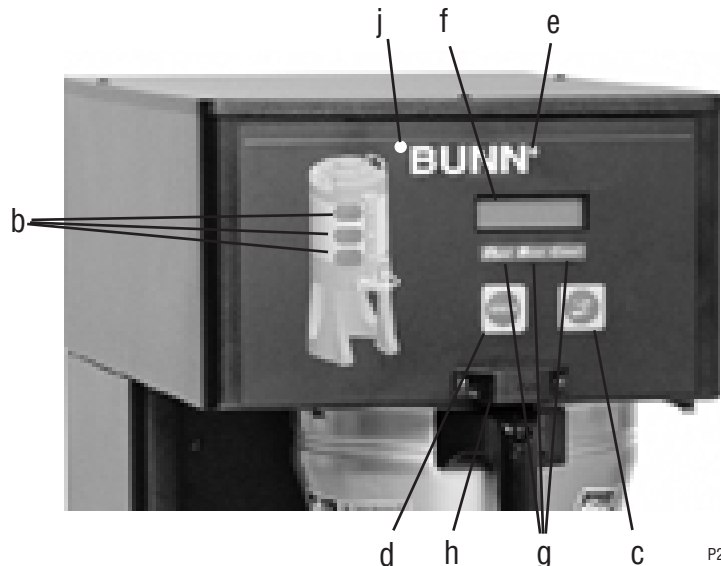
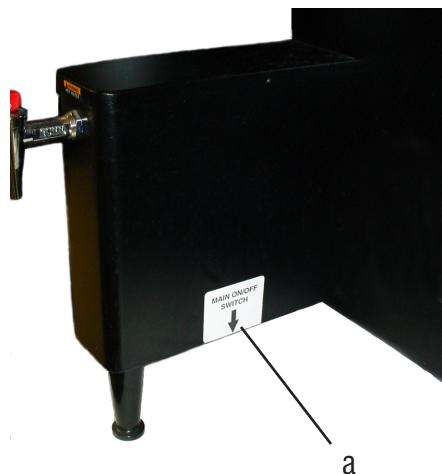

P2725

(a) MAIN ON/OFF SWITCH

This switch, located under the brewer behind the front leg, turns power on and off to all components in the brewer.

(b) BATCH SELECTOR SWITCHES

Pressing the switch corresponding to the Small, Medium, or Large batch selects the amount of coffee to be brewed. Pressing a different switch after a brew cycle has been initiated does not change the brew batch in progress. Light indicates the selected batch to brew.

(c) ON/OFF SWITCH (ENABLE BREW)

Pressing the ON/OFF switch alternately turns the brewer on and off. Pressing this switch during the brew cycle will interrupt the brew cycle, stopping the flow of water. Pressing this switch during the programming of the brewer will exit the setup and return to the main screen.

(d) BREW SWITCH

Momentarily pressing and releasing this switch begins a brew cycle.

(e) ® SWITCH

Pressing and holding the ® switch allows entry to the programming menus. Pressing and releasing the switch steps through each function screen during programming.

(f) FUNCTION SCREEN

This is the display which shows the various functions of the brewer and allows the programming to be accomplished.

(g) FUNCTION SCREEN SWITCHES

These are the hidden switches which are used to program the brewer.

(h) FUNNEL SENSING COILS

This is used to "receive" information from the Smart Funnel handle (coffee name and batch size), and also from **RECIPE CARDS**.

(j) SCROLL BACKWARDS

The upper left corner of the B in BUNN can be used to scroll backwards through the function list.

INITIAL SETUP

CAUTION – The brewer must be disconnected from the power source throughout the initial setup, except when specified in the instructions.

1. Insert an empty funnel into the funnel rails of the brew station.
2. Place an empty server under the funnel.
3. Connect the brewer to the power source. Water will begin flowing into the tank and stop when the tank is filled to its capacity. Display will show **PLEASE WAIT...TANK FILLING** until tank is filled with water.
4. Wait approximately 20 mins for the water in the tank to heat to the proper temperature on 120V/208V machines. (Wait approximately 45 mins on 120V machines). Display will show **READY TO BREW...WATER TEMP: XXX°** when tank is at operating temperature.
5. Place a small vessel beneath the faucet and open the faucet handle. Release it when you hear the tank refilling.
6. Water volumes have been preset at the factory. Refer to adjustments for the Set Brew Volumes section of this manual should the volume need to be increased or decreased.
7. The brewer is now ready for use in accordance with the coffee brewing instructions.

COFFEE BREWING

1. Insert a BUNN filter into the Smart Funnel.
2. If a grinder is not used to obtain the coffee grounds, pour the proper amount of fresh coffee grounds into the funnel and level by gently shaking. Slide the funnel into the funnel rails and select batch size. Proceed to step 5.
3. If a G9-2T DBC or MHG grinder is used with a compatible Smart Funnel, select the desired batch size on the grinder. Grind the selected amount of fresh coffee into funnel and level grounds by gently shaking. It is not necessary to select a size on the brewer.
4. Slide the funnel into the funnel rails. The brewer will read the size ground through the chip in the funnel handle and will automatically select the correct size to brew.
5. Place an empty server under the funnel.
6. The ENABLE BREW switch must be ON (indicator lit). Momentarily press and release the BREW switch. If the brewer has the funnel lock option and if it is activated, once a brew cycle has been started the funnel is locked in place. There may be certain situations in which the brew cycle will not begin when BREW switch is pressed:
 - a) ENABLE BREW must be ON.
 - b) **BREW TEMPERATURE TOO LOW** - wait until heated or cancel **BREW LOCKOUT** option.
 - c) **FUNNEL NOT IN PLACE** (or using a standard brew funnel) - cancel **FUNNEL DETECT**.
 - d) **CHECK FUNNEL** - remove funnel, empty previously brewed grounds and grind a new batch into the funnel.
7. If none of the above messages are displayed, the display will read **NOW BREWING** and the time remaining in the brew cycle.
8. Following the BREW will be a countdown **DRIPPING** time which shows the time remaining until the funnel lock will release. Discard the grounds and filter only after visible dripping stops.

CLEANING

1. The use of a damp cloth rinsed in any mild, nonabrasive, liquid detergent is recommended for cleaning all surfaces on Bunn-O-Matic equipment. Do **NOT** clean this equipment with a water jet device.
2. Check and clean each sprayhead. The sprayhead holes must always remain open.

NOTE: Any buildup on the sprayhead and fitting may restrict water flow, and impact your coffee brewing. For consistently great coffee, clean sprayhead and fittings weekly with sprayhead cleaning tool (#38227.0000). Upon visual inspection it may appear that light passes through all holes in the sprayhead plate, but a thin film of residue can pass light and still impede water flow.

3. Insert the long end of sprayhead cleaning tool into the sprayhead fitting, and rotate several times to remove any mineral deposits from the fitting.
4. Insert the short end of sprayhead cleaning tool into the bypass fitting, and rotate several times to remove any mineral deposits from the fitting.
5. Remove sprayhead from brewer. Disassemble by removing the seal.
6. Use the pointed end of sprayhead cleaning tool to remove any mineral deposits from the sprayhead holes.
7. Reassemble sprayhead and reattach. Sprayhead only needs to be hand tightened.

See page 34 of instruction manual for calibration routine to verify sprayhead flow rate matches programmed flow rate. Machine may need to be re-calibrated due to lime build up. If machine is cleaned and build up removed, machine must be re-calibrated to achieve desired volumes.

GLOSSARY

- AD CARD:** An assembly consisting of computer chips and an instruction label. Used for loading advertising messages into the brewer.
- BREW LOCKOUT:** The inability to initiate a brew if the water temperature is less than the ready temperature programmed into the brewer.
- BYPASS:** The process of diverting a portion of the brew water to the outside of the paper filter so that it does not pass through the coffee grounds. This process is sometimes used to optimize the flavor of the finished brew.
- CHIP:** A computer chip containing either recipes for specific coffee flavors or advertising messages which are read by the sensing coil on the brewer. One chip is embedded in each Smart Funnel handle to carry the coffee flavor name and batch size ground from the grinder to the brewer.
- DRIP TIME:** The length of time from when the water spray over the grounds ends, to the time that no water drips from the funnel tip.
- FACTORY DEFAULTS:** The factory preset brew settings that were installed into the brewer's memory.
- FIRST ON-TIME:** During a pulse brew, this is the time set for the initial flow of water over the grounds.
- FUNNEL DETECT:** Sets the inability to initiate a brew cycle if the funnel is not properly inserted into the funnel rails.
- FUNNEL SENSING COIL:** A sensor on the front hood of the brewer, which reads what name and batch size of coffee was ground into the funnel and allows for the brewer to automatically set itself to what is read from the funnel handle.
- LAST ON-TIME:** During a pulse brew, this is the time set for the second on-time, and each alternating on-time for the remainder of the brew cycle.
- MAIN SCREEN:** The term used to describe the screen that is displayed when the brewer is not in use. This screen is also displayed after exiting the programming mode.
- NO-NAME COFFEE:** The term for the recipe used by the brewer when there is no coffee name stored in the funnel.
- OFF-TIME:** During a pulse brew or preinfusion, this is the time set for the length of time that the water is not spraying over the grounds.
- PREINFUSION:** The process of beginning a brewing cycle with an initial spray of water onto the grounds followed by a pause in the spray. After the programmed pause, the spray continues without interruption until the end of the brewing cycle.
- PULSE BREW:** The process which allows the brew water to start, then stop, repeatedly, over the grounds in order to derive the best flavor from the coffee. Pulse brew is also used in some instances to prevent a filter overflow.
- RECIPE:** Set of brewing parameters stored in the brewer. The parameters are unique for each coffee name and include brew ounces, pulse brew, percent bypass, preinfusion and drip time.
- RECIPE CARD:** An assembly consisting of a computer chip and an instruction label. Used for loading a recipe into the brewer and the companion DBC Grinder.

PROGRAMMING

Using the menu-driven display on the front of the brewer, the operator has the ability to alter or modify various brewing parameters such as brew temperatures, brew volumes, bypass percentages, etc. This allows for the precise brewing of various flavors of coffee.

Programming of the brewer is achieved by entering a certain function. Then, by the use of hidden programming switches, the operator can customize the brewing process to their specifications.

PROGRAMMING SWITCHES

To access the programming mode, and to scroll through the different function screens, hidden programming switches are used. There are five of these switches that will be used for the setup of the brewer.

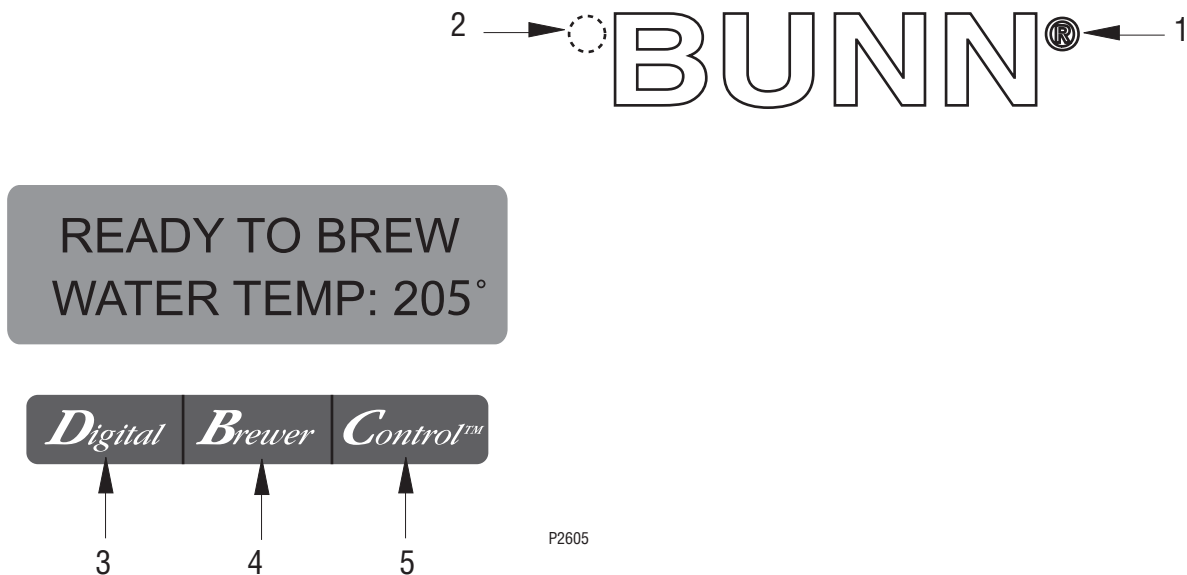

1. **® symbol** (upper right of the BUNN logo)
This is used to access the programming mode and is also used to scroll forward through the function list.
2. **Upper left corner** of the "B" in the BUNN logo
This is used to scroll backwards through the function list.
3. **"Digital"** (lower left under the display)
This is used to select options that appear on the display during programming.
4. **"Brewer"** (center under the display)
This is used to select options that appear on the display during programming.
5. **"Control"** (lower right under the display)
This is used to select options that appear on the display during programming.

PROGRAMMING THE BREWER

The programming of the brewer is divided into two levels. There is one function in Level 1. All other functions are accessed in Level 2.

The following function screens are in order of appearance. Each screen will have instructions on how to access, and the procedures to program the various functions of the brewer.

IMPORTANT PROGRAMMING NOTES - READ CAREFULLY -

To exit the programming mode at any time, press and release the ON/OFF switch located on the front switch panel. The display will return to the **MAIN SCREEN**.

If none of the five programming switches are pressed within one minute during the setup of the brewer, the programming of the function screen that is being set will be exited and the display will return to the **MAIN SCREEN**.

Always remember to place a container and funnel under the sprayhead when operating the brewer during the set-up of **PULSE BREW**, **CALIBRATE FLOW** and testing the brew and bypass valves in **SERVICE TOOLS/TEST OUTPUTS**.

MAIN SCREEN

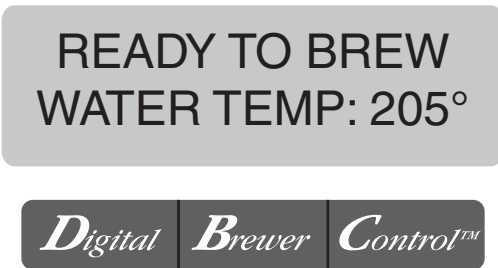

This screen will be shown when the brewer is ready for use. The screen displays the water temperature in the tank. When the water in the tank reaches the correct set temperature, the display will change from **HEATING** to **READY TO BREW**.

PROGRAMMING LOCKOUT SWITCH (mounted on main control board)

This switch can be set to prevent access to the programming levels of the brewer. Once all the correct brew settings are programmed, the operator can set the switch to the "DISABLE" position to prohibit anyone from changing the settings.

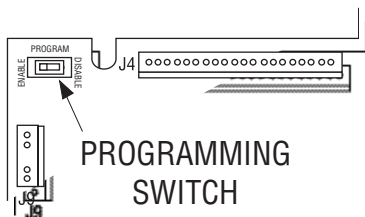

P2424

PROGRAM FUNCTIONS - LEVEL 1 BREW LOCKOUT

This function allows the operator to prevent or allow brewing if the water temperature is less than the set **READY** temperature.

To access this function screen press and hold the **®** symbol. Release the **®** when the display reads:

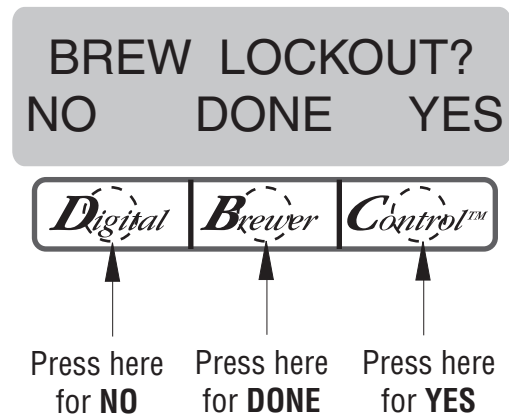

The **YES** or **NO** should be flashing. Select **YES** to prevent brewing if the water temperature is below the set **READY** temperature. Select **NO** to permit brewing at any water temperature.

When finished, press and release **DONE**. This will exit this function screen and return to the **MAIN SCREEN** on the display.

PROGRAMMING THE BREWER (cont.)

PROGRAM FUNCTIONS - LEVEL 2

There are three methods of programming the various brewing parameters of the Single TF DBC with Smart Funnel Brewer.

METHOD 1:

Using a Smart Funnel and a G9-2T DBC or MHG Grinder:

Certain coffee **NAMES** are stored in the G9-2T DBC or MHG's memory. When a particular name of coffee is ground into the Smart Funnel, that name and the batch size selected are transferred from the grinder to the programming **chip** located in the funnel's handle. The funnel is then inserted into the brewer's funnel rails. The sensor coil on the brewer reads the information contained in the handle. This then allows the operator to set the **BREW VOLUMES, BYPASS PERCENTAGES, PULSE BREW TIMES, PREINFUSION TIMES** and **DRIP-OUT TIMES** for that particular coffee **NAME**. Each coffee **NAME** can be set individually to provide optimum brewing quality.

RECIPES

This diagram allows for the creating, modifying, or viewing of recipes in the brewer.

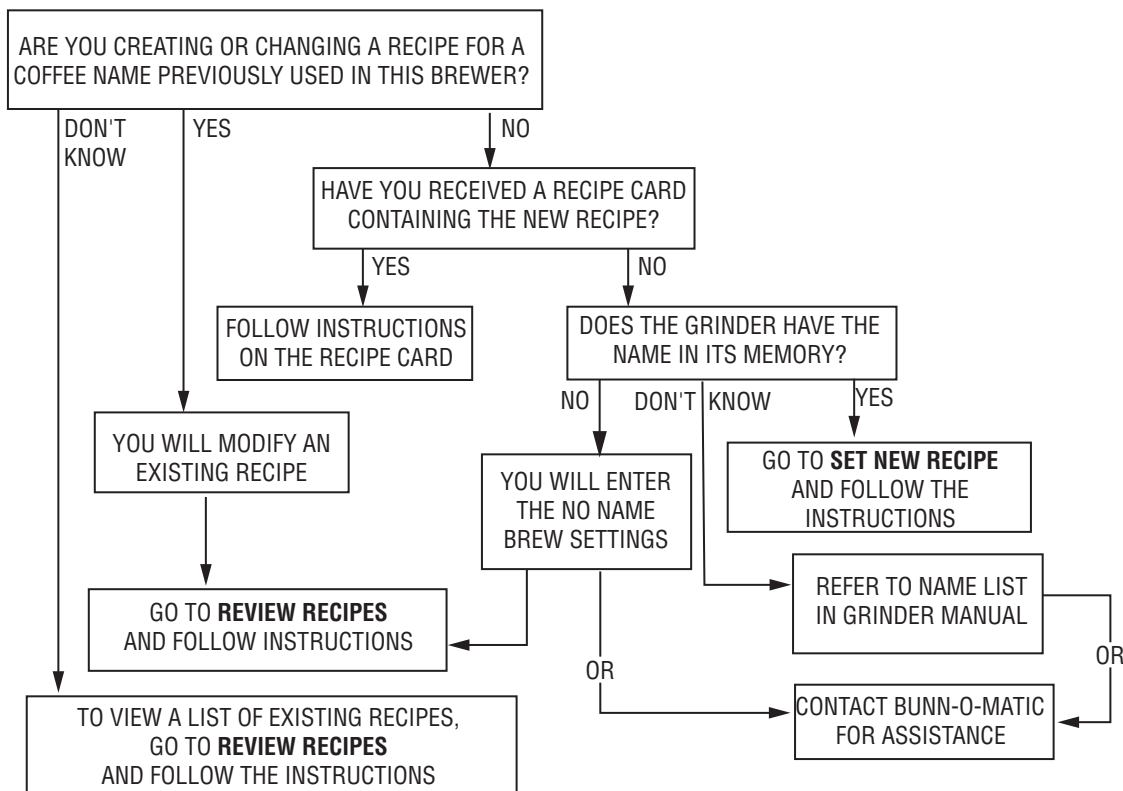

METHOD 2:

Using a RECIPE CARD to enter all of the brew settings at one time:

If using a coffee name not in the grinder's memory, the customer can obtain a **RECIPE CARD** from the factory with all the information needed to set up that particular coffee flavor. This includes the **COFFEE NAME, BREW VOLUMES, BYPASS PERCENTAGES, PULSE BREW TIMES, PREINFUSION TIMES, and DRIP-OUT TIMES**.

METHOD 3:

Not using a Smart Funnel and/or a G9-2T DBC or MHG Grinder:

This allows the operator to enter **ONE** set of brewing parameters for each side, in the event a Smart Funnel and/or a G9-2T DBC or MHG is not used with the brewer. This is referred to as a **NO NAME** coffee flavor. If the brewer does not read the information in the funnel's handle, it automatically selects the **NO NAME** brewing parameters set up prior to brewing. This includes the **BREW VOLUMES, BYPASS PERCENTAGES, PULSE BREW TIMES, PREINFUSION TIMES** and **DRIP-OUT TIMES** for the three batch sizes.

PROGRAMMING THE BREWER (cont.)
PROGRAM FLOW DIAGRAM

LEVEL I

Press upper right hidden switch for approximately 2 seconds, until the following screen appears.



Returns to normal operating mode

LEVEL II

Press upper right hidden switch for approximately 4 seconds, until "UNITS" appears on screen.

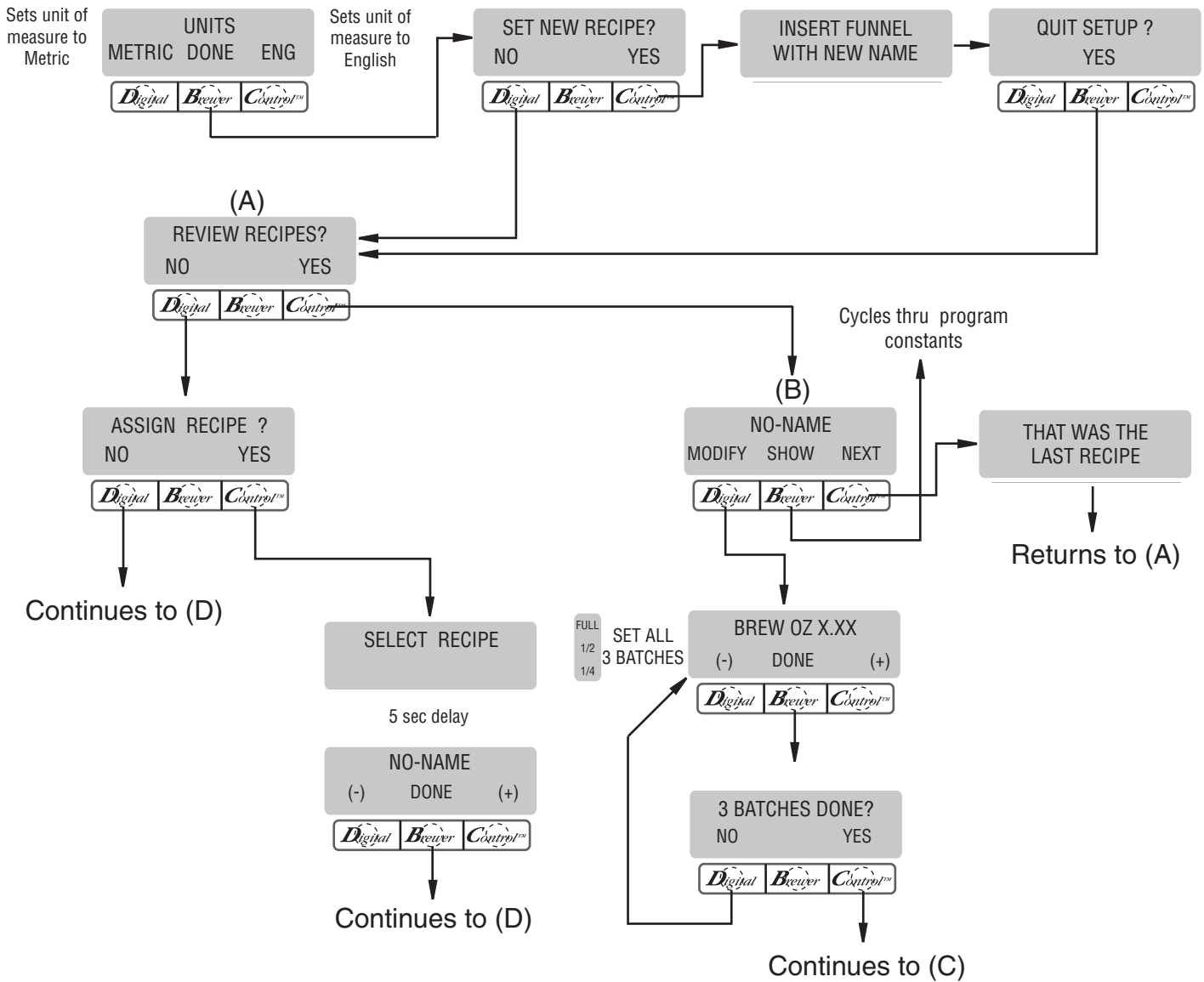

PROGRAMMING THE BREWER (cont.)

PROGRAM FLOW DIAGRAM (Cont.)

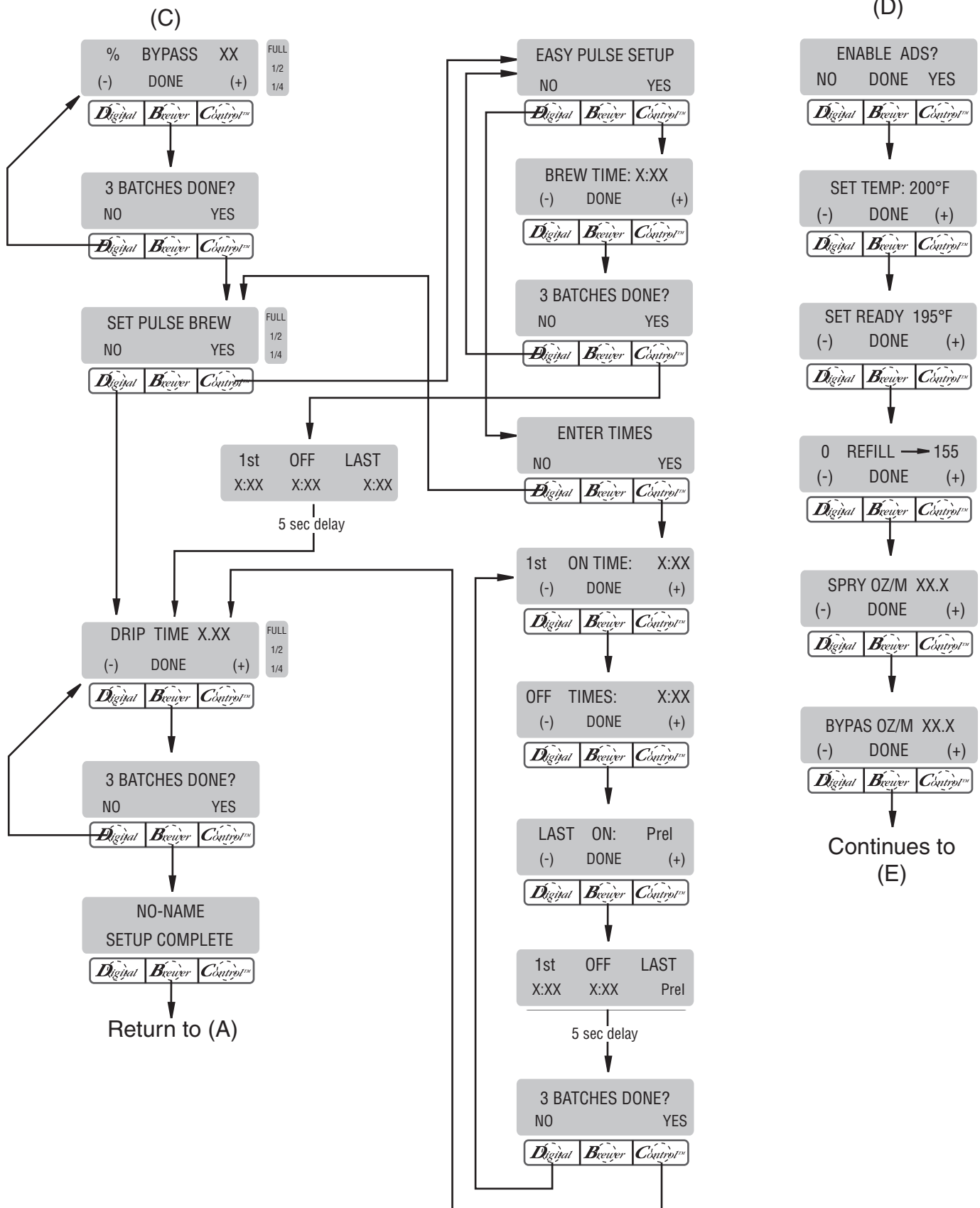

PROGRAMMING THE BREWER (cont.)

PROGRAM FLOW DIAGRAM (Cont.)

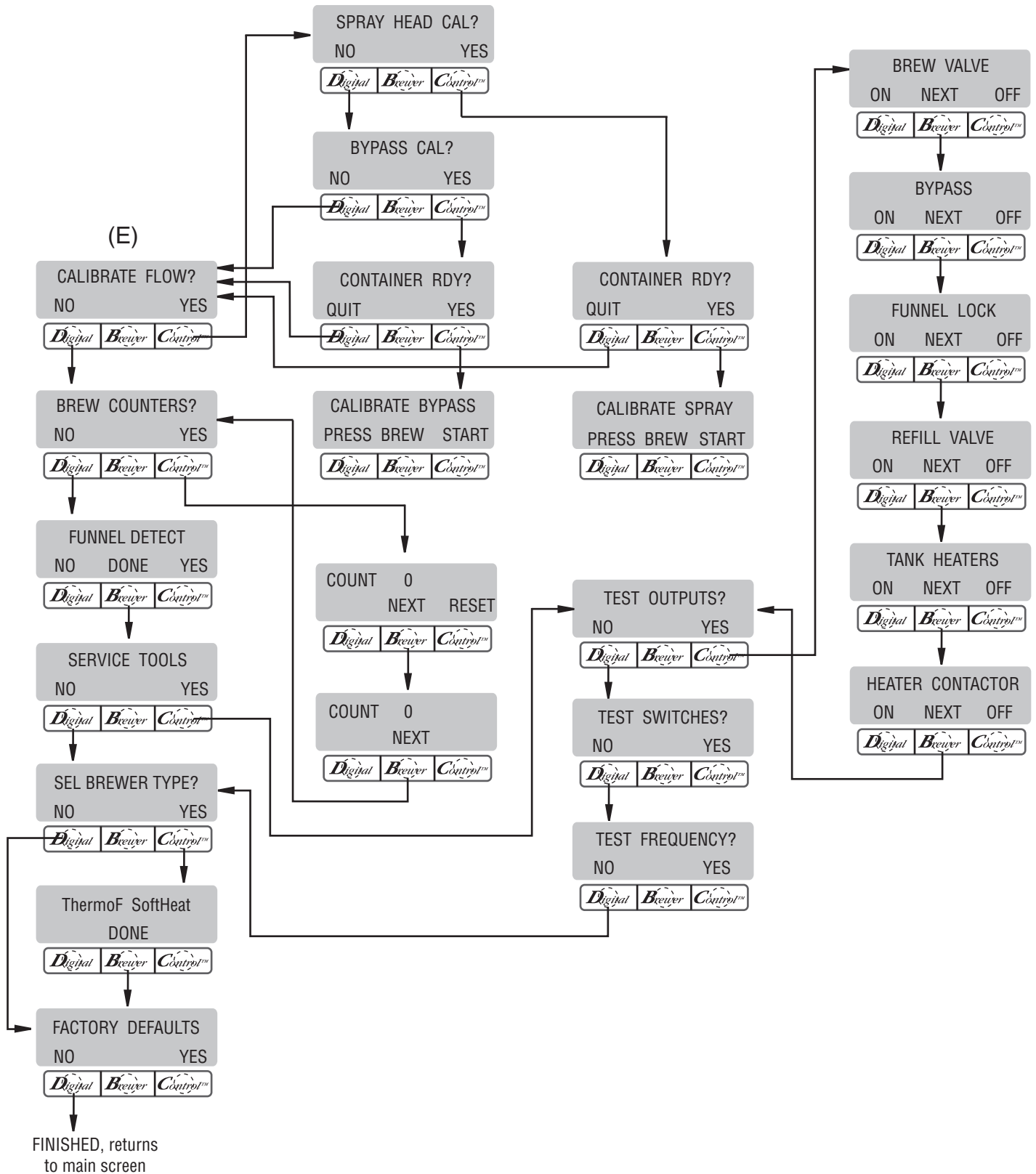

PROGRAMMING THE BREWER (cont.)

UNITS (SETTING UNITS OF MEASURE)

This function allows the units of measure to be set in English or Metric readings for all screens. The program is defaulted to English.

WARNING: Changing the unit of measure will erase all coffee recipes stored in memory. All preinfusion, pulse times, etc will also be erased. If using this option after information has been stored, it is important to have this information stored elsewhere so that the machine can be reprogrammed.

Procedure for modifying units of measure:

1. Press and hold upper right hidden switch until the display reads **UNITS**. Release switch. Press and release **METRIC** or **ENG** to make a selection.

2. Press **DONE** to proceed. The display should now read **CHANGING UNITS!! WILL ERASE!! ... ALL PREVIOUSLY STORED RECIPES AND ALL SETUP INFO WILL BE LOST ... ARE YOU SURE?**
3. Press **YES** to begin the change. While the change is in process, the display will read **RESTORING DEFAULTS** and a count down will begin.
4. When the count down reaches 0 the display will read **SET NEW RECIPE?**. The units have been reset.
5. Press and release either of the ON/OFF switches located on the front switch panel to exit the **UNITS** function and return to the **MAIN SCREEN**.

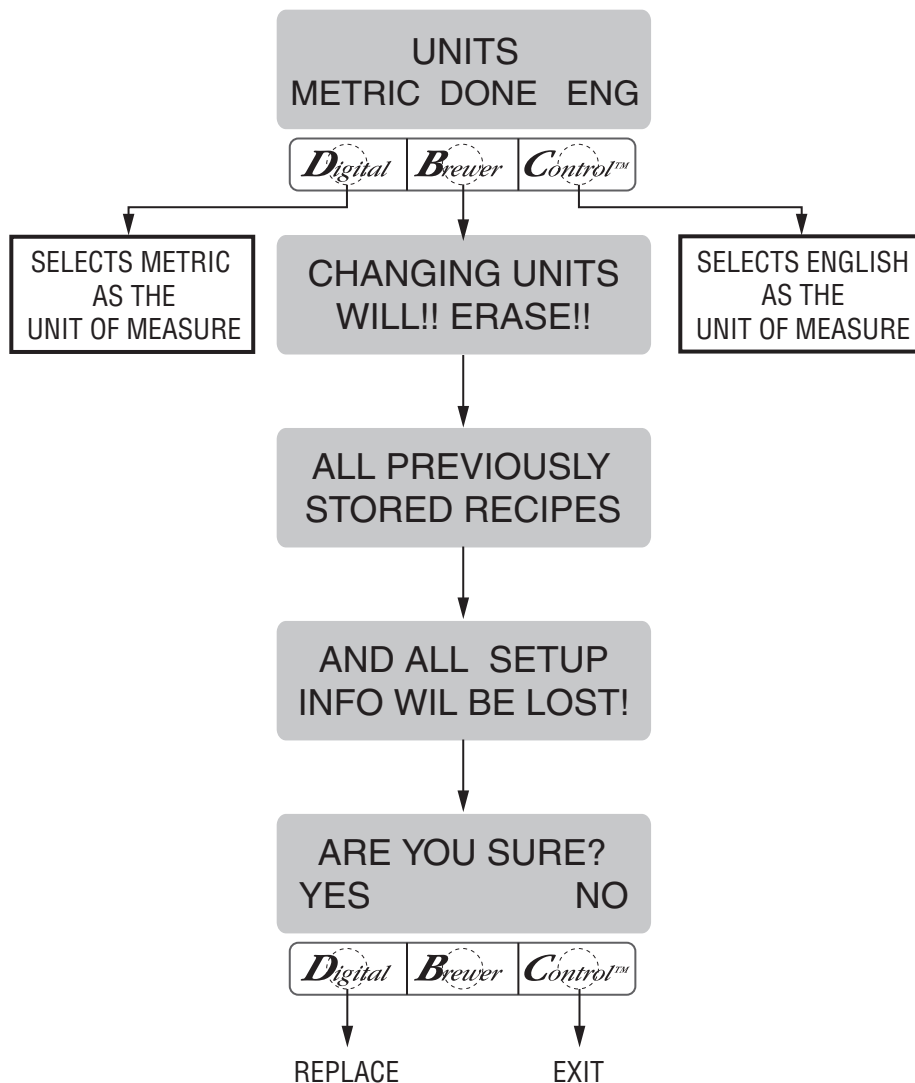

P3260

PROGRAMMING THE BREWER (cont.)

SET NEW RECIPE

Using a Smart Funnel and a G9-2T DBC or MHG Grinder:

This function allows the operator to set **BREW VOLUMES, BYPASS PERCENTAGES, PULSE BREW TIMES** and **DRIP-OUT TIMES** for each coffee name preset in the grinder's memory.

Certain coffee **NAMES** are stored in the grinder's memory. When a particular name of coffee is ground into the Smart Funnel, that name and the batch size selected are transferred from the grinder to the programming **chip** located in the funnel handle. The funnel is then inserted into the brewer's funnel rails. The sensor coil on the brewer reads the information contained in the handle. The name of the coffee flavor will then appear on the display. This allows the operator to set the **BREW VOLUMES, BYPASS PERCENTAGES, PULSE BREW TIMES** and **DRIP-OUT TIMES** for that particular coffee **NAME**. It also allows the operator to set other brewing parameters, such as **BREW TEMPERATURE, READY TEMPERATURE, BREW LOCKOUTS**, etc. Each coffee **NAME** can be set individually to provide optimum brewing quality.

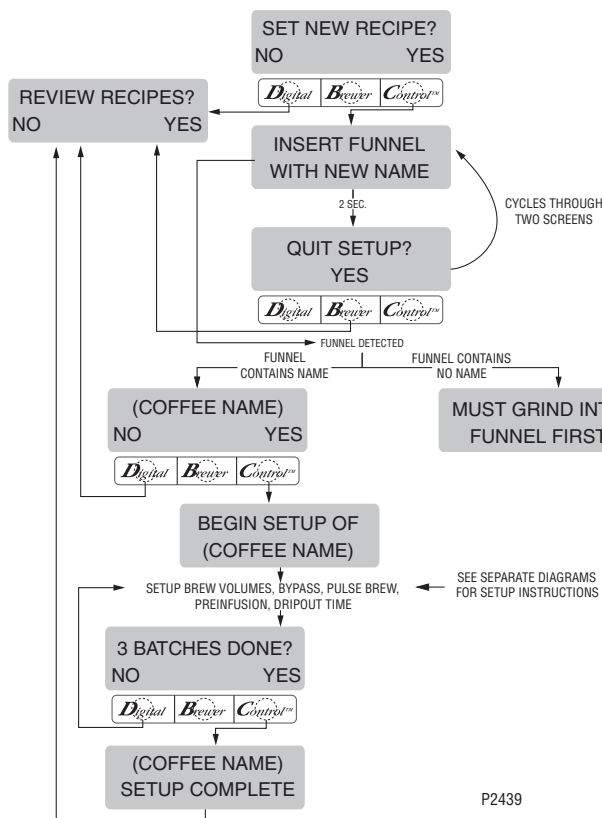

P2439

Procedure for Setting the Recipe:

NOTE: Before beginning setup, place a server beneath the brew funnel.

1. Insert the funnel into the grinder and select a batch size to grind. It is not necessary to have coffee beans in the hopper(s) in order to program the brewer. The coffee name is pre-selected and stored in the grinder's memory for the side being ground.
2. Press the GRIND switch. When the grinder stops grinding, remove the funnel.
3. On the brewer, press and hold the upper right hidden switch until the display reads **UNITS**. Release the switch, then press and release the switch again until the display reads **SET NEW RECIPE**.
4. Press and release **YES**. The display should read **INSERT FUNNEL WITH NEW NAME**, then **QUIT SETUP?** These three displays will repeatedly cycle.
5. Insert the funnel into the rails of the brewer. The display should read the **NAME** of the coffee that was ground into the funnel, along with a **NO** and **YES**. If the **NAME** on the display is correct, press **YES**.
6. If, for some reason, the name of the coffee from the grinder did not load properly into the funnel, or if a grind has not yet been done, the display will read **MUST GRIND INTO FUNNEL FIRST**. It will be necessary to grind another batch following steps 1 and 2.
7. If the grind is acknowledged by the brewer, the display will read **BEGIN SETUP OF (COFFEE NAME)**. Then the screen will display **BREW OZ.** and a batch light will be blinking. (Refer to **BREW OZ. SETTING OR ADJUSTING** for description).

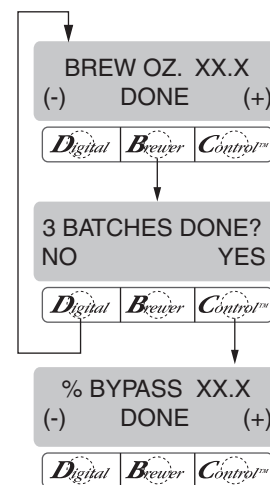

P2415

PROGRAMMING THE BREWER (cont.)

SET NEW RECIPES (cont.)

8. Using (-) and (+), set the amount of brew water, in ounces, to be dispensed for that particular batch size.
9. When finished, press another batch size and repeat step 8 for that size. Continue setting all batch sizes.
10. When finished setting all batch sizes, press and release **DONE**. The display should read **3 BATCH SIZES DONE?**
11. If the three batch sizes are not correct, press and release **NO** to return to the **BREW OUNCES** setup screen and repeat steps 8 through 10. If the three batch sizes are correct, press **YES**. This will advance to the **% BYPASS** function. (Refer to **% BYPASS** for description).

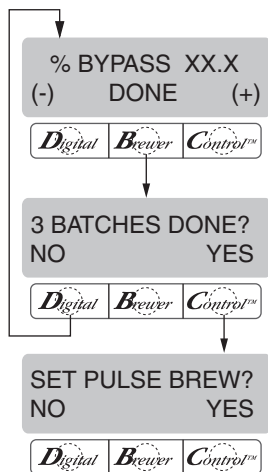

P2416

12. Using (-) and (+) set the amount of bypass water (percentage) to be dispensed **around** the grounds for that particular batch size.
13. When finished, press another batch size and repeat step 12 for each batch to be set.
14. When finished setting each batch size, press **DONE**. The display should read **3 BATCHES DONE?**
15. If the three batch sizes are not correct, press and release **NO** to return to the **% BYPASS** setup screen and repeat steps 12 through 15. If they are correct, press **YES**. This will advance to **SET PULSE BREW**. (Refer to **SET PULSE BREW** for description).
16. To **SET PULSE BREW**, if setting pulse brew using **EASY PULSE** (brewing into a funnel) press **YES** and proceed with the setup instructions for **SETTING PULSE BREW - EASY PULSE**.
17. If setting pulse brew by **ENTER TIMES** (entering known times) press **NO**. The display should read **ENTER TIMES**. Press and release **YES** and proceed

with the setup instructions for **SETTING PULSE BREW - ENTER TIMES**. **SET DRIP TIME**. (Refer to **SET DRIP TIME** for description).

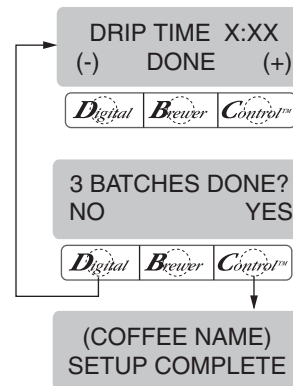

P2418

18. The display should now read **DRIP TIME**, along with either the word **OFF**, or a time will be showing. A batch light should also be blinking.
19. Using (-) and (+), set the amount of time from when the brew spray ends to when the funnel is emptied of hot liquid for that batch size.

NOTE: Set to **OFF** to prevent funnel locks from engaging (to disable this function), for a particular batch size. To set to **OFF**, continue to press and release (-) until **OFF** appears on the screen.

20. When finished, press another batch size and repeat step 19 until all three sizes are set.
21. When finished setting all batch sizes press **DONE**. The display should read **3 BATCHES DONE?**
22. If the three batch sizes are not correct, press **NO** to return to the **DRIP TIME** setup screen and repeat steps 19 through 21.
23. If the three batch sizes are correct, press **YES**. The screen should show the name of the coffee being programmed (modified) along with **SETUP COMPLETE**.
24. After a 5 second delay, the display will advance to the next coffee name in the brewer's memory. If no other coffee names are present, the display will read **THAT WAS THE LAST RECIPE**, and return to the **REVIEW RECIPES** screen.

PROGRAMMING THE BREWER (cont.)

SET NEW RECIPE

Using a RECIPE CARD to load coffee names and brew settings into the Brewer with Smart Funnel:

The G9-2T DBC or MHG's memory contains certain coffee names. If the operator uses a coffee name that is not already stored in the grinder's memory, a **RECIPE CARD** can be obtained from the factory. The **RECIPE CARD** would include all the information needed to set up that particular coffee name. The information from the **RECIPE CARD** is loaded into the grinder's memory, then into the brewer's memory by holding the chip area up to the equipment's sensing coil. This information can include the coffee name, **BREW VOLUMES, BYPASS PERCENTAGES, PULSE BREW TIMES** and **DRIP-OUT TIMES** for that particular coffee **NAME**. These can all be loaded in seconds.

Contact Bunn-O-Matic Corporation for the availability of **RECIPE CARDS**.

NOTE: Instructions to program the brewer and grinder are printed on the **RECIPE CARD**, along with the coffee name that is being programmed.

Procedure to program the coffee name:

1. Remove the funnels (if present) from the left and right funnel rails.
2. Position the **RECIPE CARD** vertically, so that the top end of the **CHIP** is beneath the left side funnel sensing coil.
3. After a short pause the display will read **CARD CONTAINS RECIPE FOR** then will change to **(COFFEE NAME) SHOW QUIT SAVE**. All brewing parameters for that coffee name are now transferred from the **CARD** to the brewer.
4. To show (view) this information, press and release **SHOW**. The display will scroll through all of the brew settings for all three batch sizes. The display will then return to **CARD CONTAINS RECIPE FOR** then will change to **(COFFEE NAME) SHOW QUIT SAVE**.
5. If all brew settings are correct, press **SAVE**. The display will read **(COFFEE NAME) SETUP COMPLETE**. All brew settings for that name are now stored in the brewer's memory.

6. If the brewing information is not correct, or it is desired to exit the setup before the settings are loaded into the brewer's memory, press **QUIT**. The display will read **(COFFEE NAME) NOT SAVED**. The display will then return to the **MAIN SCREEN**.

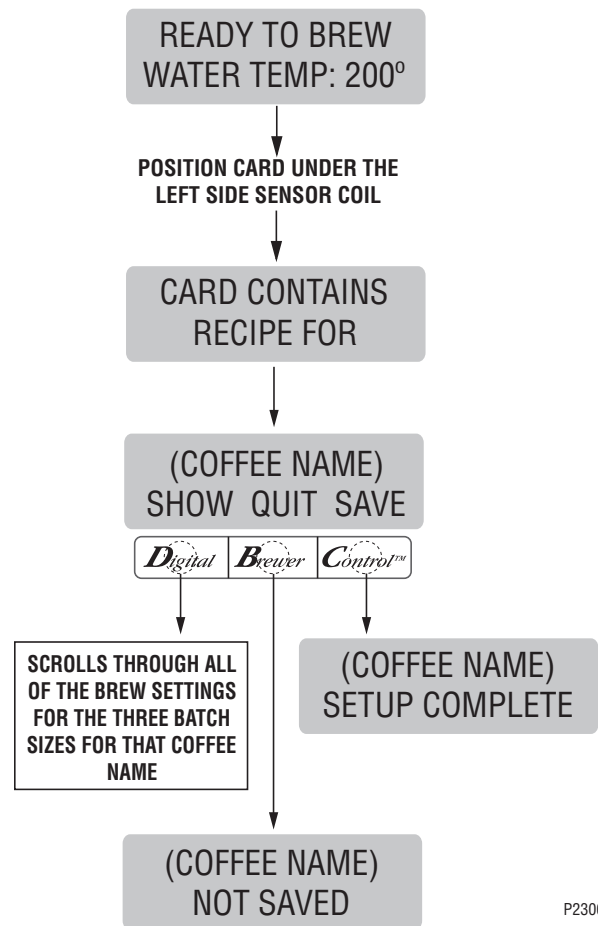

P2300

PROGRAMMING THE BREWER (cont.)

SET NEW RECIPE:

If not using a Smart Funnel (with a sensor coil) and/or a G9-2T DBC or MHG Grinder, the brewer will function as a standard Bunn Single TF DBC Brewer:

It is possible to operate the brewer without using a Smart Funnel and/or a G9-2T DBC or MHG Grinder. If a standard funnel, or if a non-DBC grinder is used the brewer will automatically select a **NO NAME** coffee name when the BREW switch is pressed. This means that no name was read from the funnel's handle.

There is one **NO NAME** coffee program that can be set in the brewer. It is referred to as **NO NAME**.

The instructions for programming the **NO NAME** settings are on the following pages. The same steps are followed for setting the recipe as those that are used to **MODIFY A RECIPE**, beginning on page 21.

Note that when the display reads **NO NAME**, that is when **MODIFY** should be pressed in order to set the parameters for the **NO NAME** coffee.

NOTE: Before beginning setup, insert a funnel into the funnel rails, and place a ThermoFresh Server beneath the brew funnel.

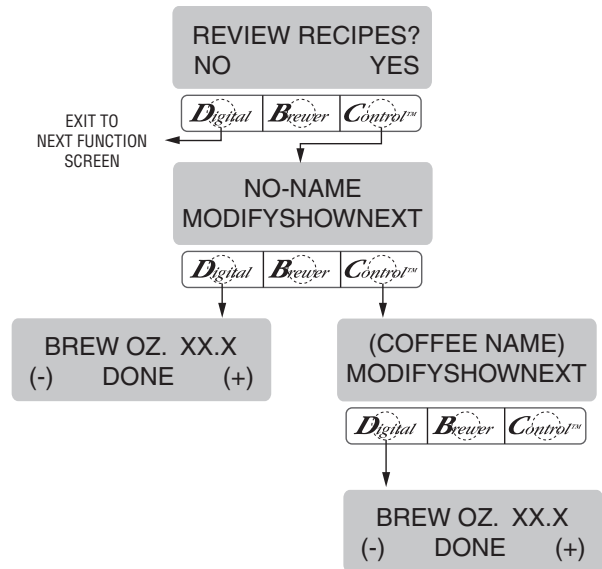

P2441

PROGRAMMING THE BREWER (cont.)

REVIEW RECIPES/MODIFY RECIPES/SET UP NO NAME COFFEE NAMES:

This function has three parts. It allows the operator to view the brew settings for the various coffee names programmed into the brewer.

It also allows the operator to modify (change) any of the **BREW VOLUMES**, **BYPASS PERCENTAGES**, **PULSE BREW TIMES** and **DRIP-OUT TIMES** for a particular coffee name programmed into the brewer.

Finally, this function is used to set up the **NO NAME** coffee **BREW VOLUMES**, **BYPASS PERCENTAGES**, **PULSE BREW TIMES** and **DRIP-OUT TIMES**.

Procedure for reviewing recipes:

- Press and hold the **Ⓜ** pad until the display reads
 - Press and hold the upper right hidden switch **Ⓜ** until the display reads **UNITS**. Release the switch, then press and release switch until the display reads **REVIEW RECIPES**.

- Press **YES** to proceed. The display should now read **NO-NAME**, along with **MODIFY**, **SHOW** and **NEXT**.
- Press and release **SHOW**. The screen will scroll through all the brew settings for that particular coffee name. When finished, the display will return to the coffee name just viewed.
- To see settings again, press **SHOW**. To advance to the next coffee name, press **NEXT**.
- To exit, press **NEXT** until the display reads **THAT WAS THE LAST RECIPE**.
- After 5 seconds, the display will return to the **REVIEW RECIPES** screen. Press and release **NO** to advance to the next function screen, or press and release the ON/OFF switch located on the front switch panel to exit the programming mode and return to the **MAIN SCREEN**.

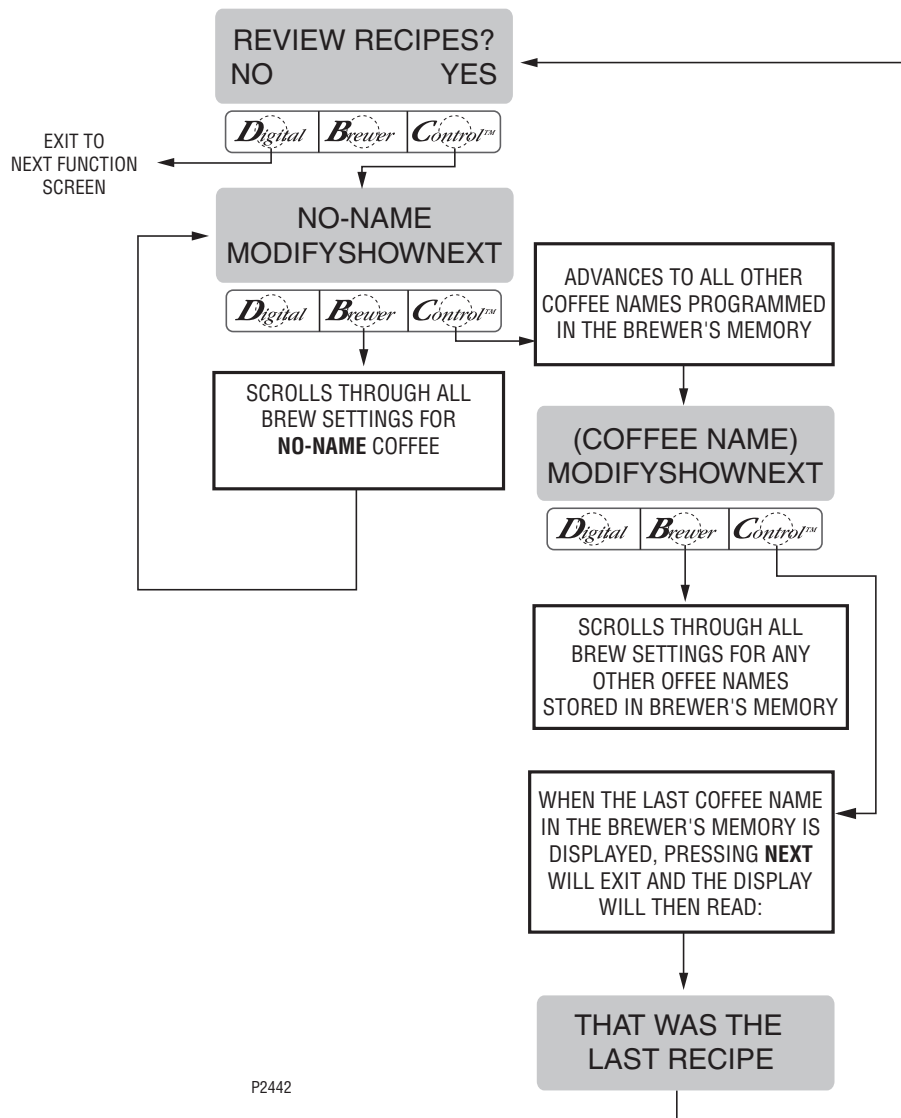

PROGRAMMING THE BREWER (cont.)

BREW OZ (SETTING OR ADJUSTING BREW VOLUMES)

This function allows adjustment of the brew volumes for each batch. The indicator signifies volume in ounces per batch.

Procedure for modifying recipes - brew ounces: Range: 10.0 oz to 400 oz for all three batch sizes

1. Press and hold the upper right hidden switch until the display reads **UNITS**. Release the switch, then press and release switch again until the display reads **REVIEW RECIPES**.
2. Press **YES** to proceed. The display should now read **NO NAME**, along with **MODIFY, SHOW** and **NEXT**.
3. Press and release **NEXT** to advance to the desired coffee name to be modified.
4. Press and release **MODIFY**. The display should read **BREW OZ** and a batch light will be blinking.

5. Press and release the batch size to be modified.
6. Using **(-)** and **(+)**, set the amount of brew water, in ounces, to be dispensed **over** the grounds for that particular batch size.
7. When finished, press another batch size and repeat step 5 for that size for each batch size to be modified. Continue setting all batch sizes.
8. When finished setting all batch sizes, press and release **DONE**. The display should read **3 BATCH SIZES DONE?**
9. If the three batch sizes are not correct, press and release **NO** to return to the **BREW OUNCES** setup screen and repeat steps 5, 6 and 7.
10. If the three batch sizes are correct, press **YES**. This will advance to the **% BYPASS** function. Another alternative is to press the ON/OFF switch to exit the **BREW OZ** setup and return to the **MAIN SCREEN**.

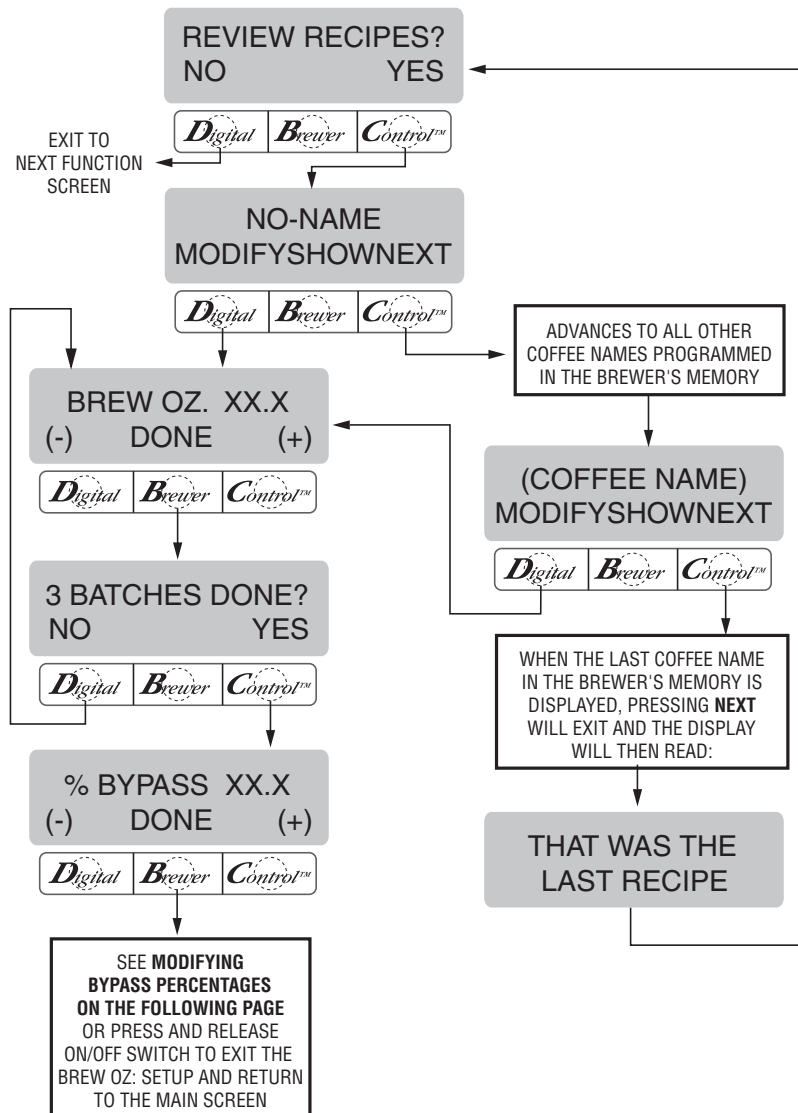

PROGRAMMING THE BREWER (cont.)

% BYPASS

This function allows adjustment of the amount of water that bypasses the grounds. The number signifies the percentage of the brew volume which does not flow over the coffee grounds.

Modifying recipes - bypass percentages:

Range: 0% to 90% for all three batch sizes

NOTE: If the brewer is already in the % **BYPASS** screen, it is not necessary to follow steps 1 through 6 in this section, but proceed directly to step 7.

1. Press and hold the upper right hidden switch until the display reads **UNITS**. Release the switch, then press and release switch until the display reads **REVIEW RECIPES**.
2. Press **YES** to proceed. The display should now read **NO NAME**, along with **MODIFY**, **SHOW** and **NEXT**.
3. Press and release **NEXT** to advance to the desired

coffee name to be modified.

4. Press and release **MODIFY**. The display should read **BREW OZ**.
5. Press and release **DONE**. The display should read **3 BATCHES DONE?**
6. Press and release **YES**. The display should now read % **BYPASS**, and a batch light will be blinking. Press and release the batch size to be modified.
7. Using **(-)** and **(+)** set the amount of bypass water (percentage) to be dispensed **around** the grounds for that particular batch size.
8. When finished, press another batch size and repeat step 7 for each batch to be modified.
9. When finished setting all batch sizes, press **DONE**. The display should read **3 BATCHES DONE?**
10. If they are not correct, press and release **NO** to return to the % **BYPASS** setup screen.
11. If the 3 batch sizes are correct, press **YES**. This will advance to **SET PULSE BREW**. Another alternative is to press the ON/OFF switch to exit the % **BYPASS** setup and return to the **MAIN SCREEN**.



P2444

PROGRAMMING THE BREWER (cont.)

SET PULSE BREW:

This function allows the operator to program the brewer to "pulse" the sprayhead flow on and off continually during a brew cycle (start and stop the flow of water out of the sprayhead). This feature allows the ability to "fine-tune" the brewer for specific flavor profiles. Pulse brewing can be set up for any and all batches.

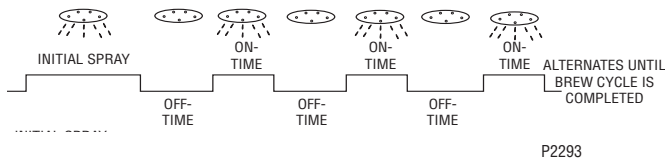

- a) **1st ON TIME** - This time is the duration from when the BREW switch is pressed to when the desired water level in the funnel is reached. (Soaking the grounds)
- b) **OFF-TIME** - This time is the duration from when the water in the funnel reaches the desired **ON TIME** level to when it drains out of the funnel to a desired lower level.
- c) **LAST ON-TIME** - This time is the duration from when the water in the funnel drains down to the lower level to when it fills the funnel to a desired higher level. (Soaking the grounds).

These three times can be set two different ways. The first is accomplished by utilizing the **EASY PULSE** screen and following the subsequent steps under that function.

The other allows the actual times to be entered for each of the settings. This is done by utilizing the **ENTER TIMES** screen and following the subsequent steps under that function.

Either of these methods can be used to set the pulse brew for each batch.

Modifying pulse brew:

Range: 1st on time - off to 4 minutes

Off time - off to 4 minutes

Last on time - off to 4 minutes

NOTE: If the brewer is already in the **SET PULSE BREW** screen, it is not necessary to follow steps 1 through 8 in this section, but proceed directly to step 9.

1. Press and hold the upper right hidden switch (®) until the display reads **UNITS**. Release the switch, then press and release the switch until the display reads **REVIEW RECIPES**.
2. Press **YES** to proceed. The display should now read **NO NAME**, along with **MODIFY**, **SHOW** and **NEXT**.
3. Press and release **NEXT** to advance to the desired coffee name to be modified.
4. Press and release **MODIFY**. The display should read **BREW OZ**.
5. Press and release **DONE**. The display should read **3 BATCHES DONE?**.
6. Press and release **YES**. The display should now read **% BYPASS**.
7. Press and release **DONE**. The display should read **3 BATCHES DONE?**.
8. Press and release **YES**. The display should now read **SET PULSE BREW**.
9. Press and release **YES**. The display should now read **EASY PULSE SETUP**.
10. If setting pulse brew using **EASY PULSE** (brewing into a funnel) press **YES** and proceed with the setup instructions for *SETTING PULSE BREW - EASY PULSE SETUP*.
11. If setting pulse brew by **ENTER TIMES** (entering known times) press **NO**. The display should read **ENTER TIMES**. Press and release **YES** and proceed with the setup instructions for *SETTING PULSE BREW - ENTER TIMES*.

PROGRAMMING THE BREWER (cont.)

SET PULSE BREW (cont.)

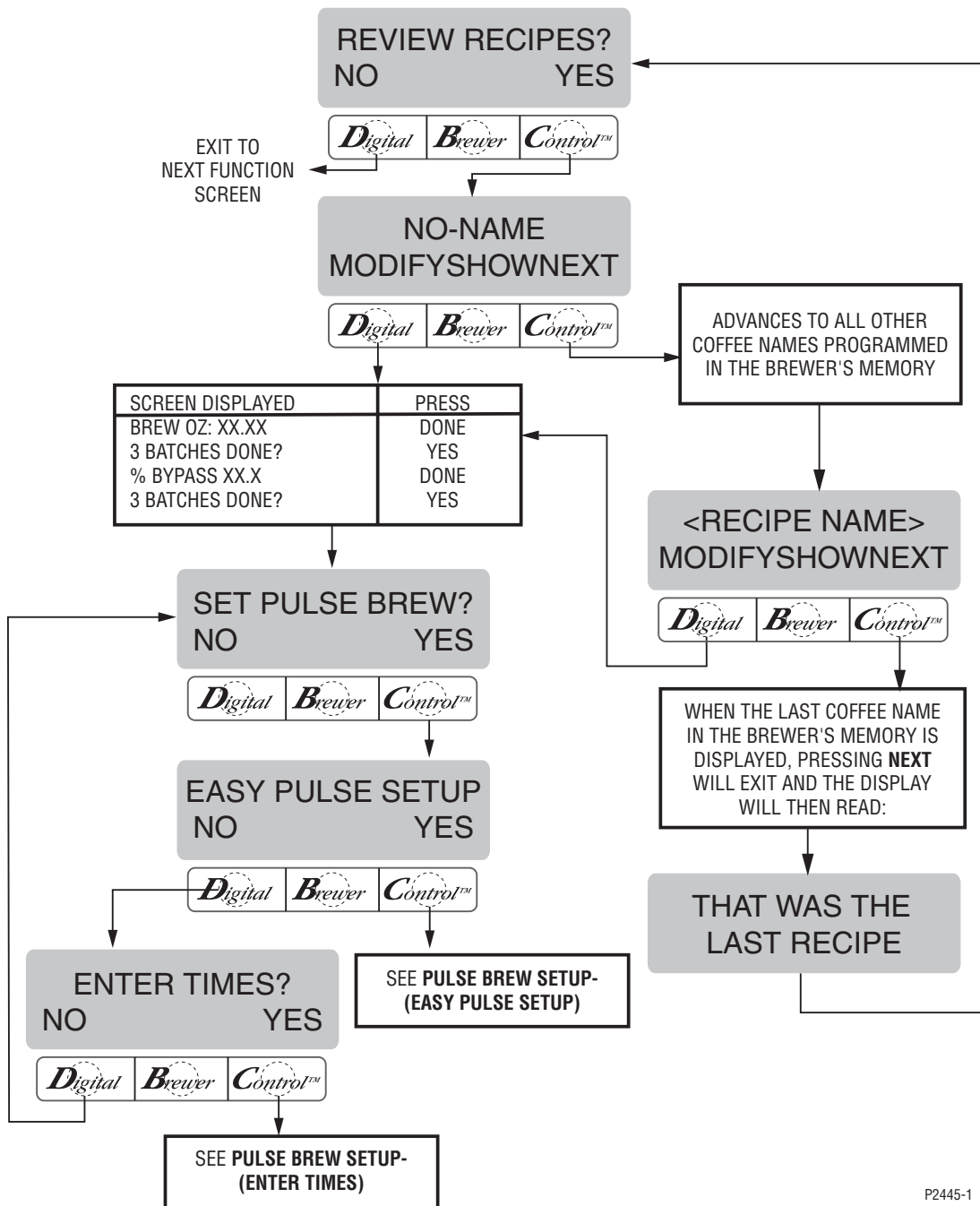

P2445-1

PROGRAMMING THE BREWER (cont.)

SET PULSE BREW - EASY PULSE SETUP

NOTE: The procedure to enter the *PULSE BREW* function must be performed prior to following the steps listed below.

1. The display should read **BREW TIME: X.XX** and a batch size indicator will be flashing.
2. Using (-) and (+), set the desired brew time for the selected batch size.

3. When finished, select another batch size to be set by pressing the switch next to the indicator light. Repeat step 2 for each batch size to be set.
4. When finished setting all batch sizes, press done. The display should read **3 BATCHES DONE ?**.
5. If the three batch sizes are not correct, press and release **NO** to return to **BREW TIME** setup screen and repeat steps 2 thru 4. If they are correct, press **YES**. This will display the **1st, OFF, and LAST** times for 5 seconds, then advance to the **DRIP TIME** setup. (See *DRIP TIME SET UP*)

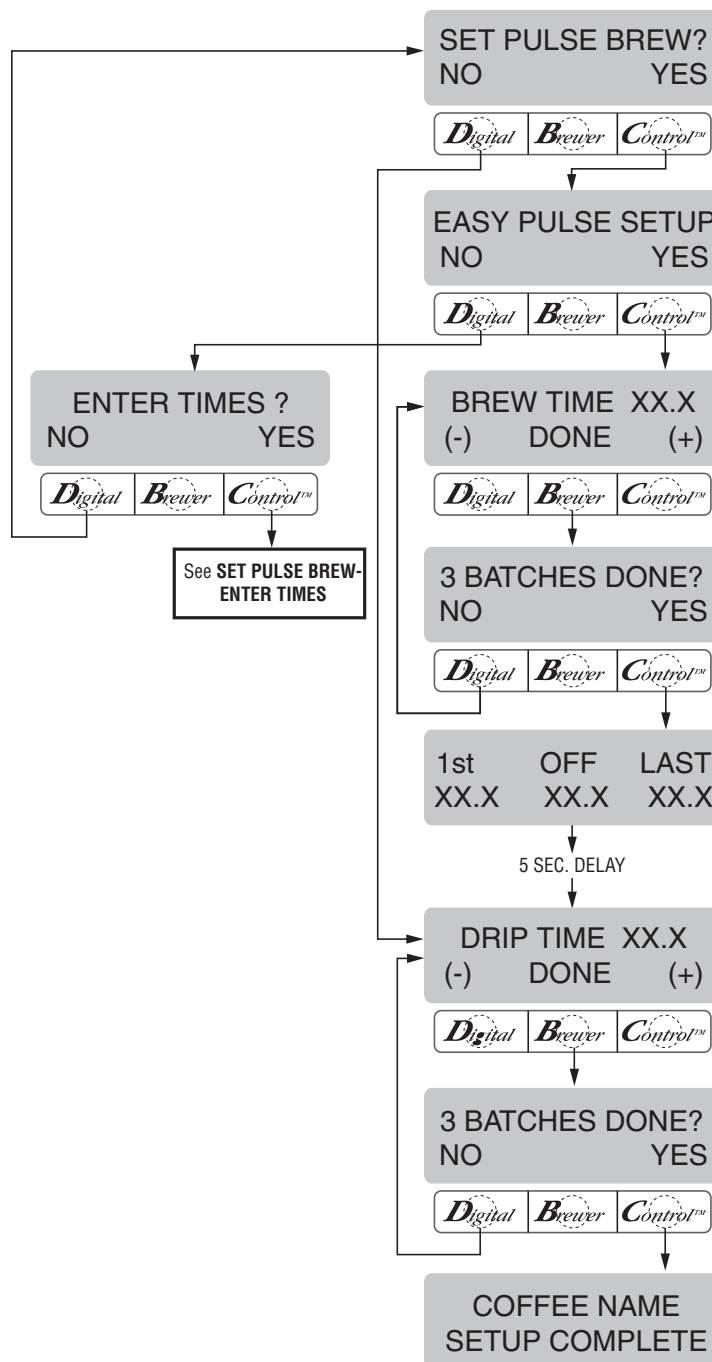

PROGRAMMING THE BREWER (cont.)

SET PULSE BREW - ENTER TIMES

NOTE: The procedure to enter the *PULSE BREW* function must be performed prior to following the steps listed below.

1. Press and release **YES**. The display should now read **EASY PULSE SETUP**.
2. Press and release **NO**. The display will read **ENTER TIMES?**
3. Press **YES** to proceed. The display should now read **1st ON TIME X:XX**.
4. Using **(-)** and **(+)** set the amount of time the flow of water into the funnel will be on.
5. When finished, press **DONE**. The display will now read **OFF TIMES: X:XX**.
6. Using **(-)** and **(+)** set the amount of time the flow of water into the funnel will be off.
7. When finished, press **DONE**. The display will now read **LAST ON: X.XX**.
8. Using **(-)** and **(+)** set the amount of time the water will be on to complete the brew.
9. When finished, press **DONE**. The display will show the three times just entered for that batch size. After a 5 second delay, the display will read **3 BATCHES DONE?**
10. If other batch sizes need to be modified, press **NO**.
12. Press a different batch size and repeat steps 3 through 7. Repeat until all the desired batch sizes are set.
13. When finished press **YES** in **3 BATCHES DONE?**. The display will then read **DRIP TIME**.
14. Press and release the ON/OFF switch located on the front switch panel to exit the **SET PULSE BREW** function and return to the **MAIN SCREEN**.

NOTE: Pressing the upper right hidden button before reaching the final setting screen exits the setup and retains the old values.

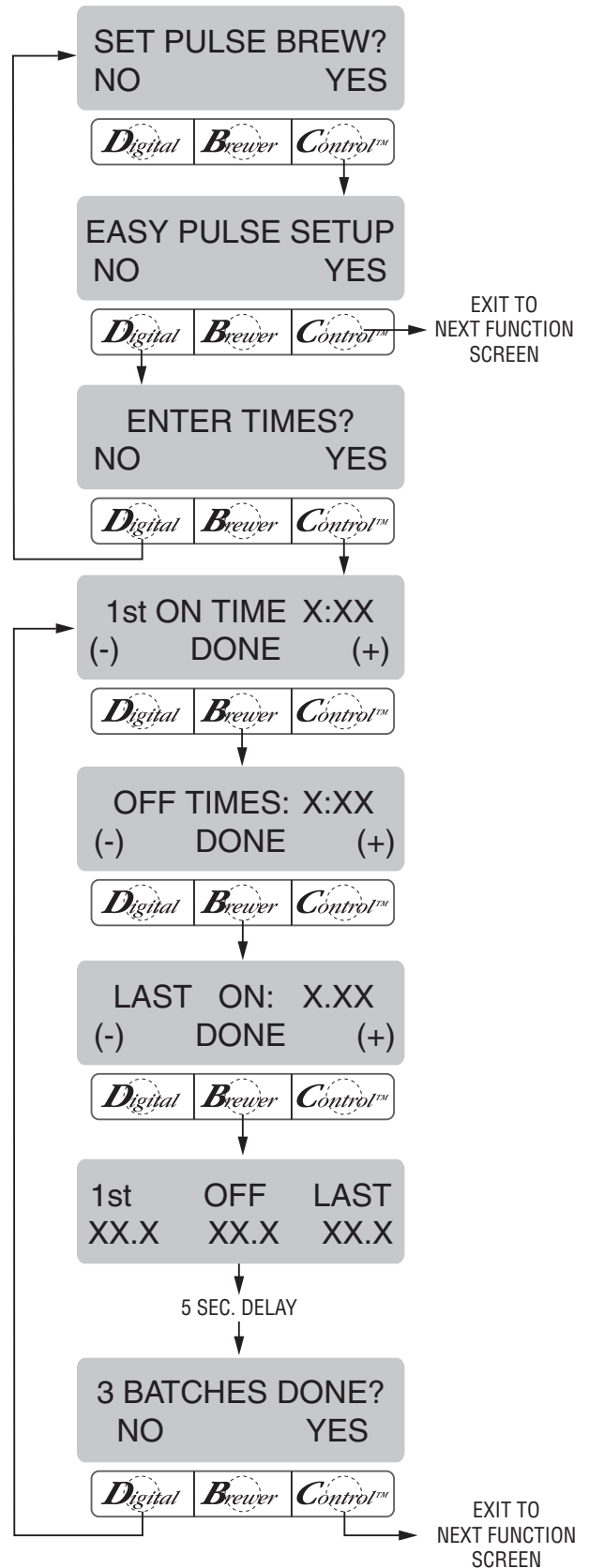

PROGRAMMING THE BREWER (cont.)

SET PREINFUSION:

This function sets the brewer to turn the sprayhead flow on for a preset time (1st ON TIME) followed by a preset spray pause (OFF TIMES) and then turn the spray on continuously until the brew volume is completed.

This is a special case of pulse brew. It is not possible to set a batch size to have both pulse brew and preinfusion. One or the other (or neither) must be chosen. However, it is possible to set one batch size to pulse brew and the other two to preinfusion or vice versa.

NOTE: The procedure to enter the *PULSE BREW* function must be performed prior to following the steps listed below.

1. Press and release **YES**. The display should now read **EASY PULSE SETUP**.
2. Press and release **NO**. The display will read **ENTER TIMES?**
3. Press **YES** to proceed. The display should now read **1st ON TIME X:XX**.
4. Using **(-)** and **(+)** set the amount of time the flow of water into the funnel will be on.
5. When finished, press **DONE**. The display will now read **OFF TIMES: X:XX**.
6. Using **(-)** and **(+)** set the amount of time the flow of water into the funnel will be off.
7. When finished, press **DONE**. The display will now read **LAST ON: Prel**
8. If the display shows a time use **(-)** and **(+)** to set it to read **Prel**. (Prel is an abbreviation for preinfusion)
9. When finished, press **DONE**. The display will show the two settings and Prel just entered for that batch size. After a 5 second delay, the display will read **3 BATCHES DONE?**
10. If other batch sizes need to be modified, press **NO**.
12. Press a different batch size pad and repeat steps 3 through 7. Repeat until all the desired batch sizes are set.
13. When finished press **YES** in **3 BATCHES DONE?**. The display will then read **DRIP TIME**.
14. Press and release the ON/OFF switch located on the front switch panel to exit the **SET PULSE BREW** function and return to the **MAIN SCREEN**.

NOTE: Pressing the upper right hidden button before reaching the final setting screen exits the setup and retains the old values.

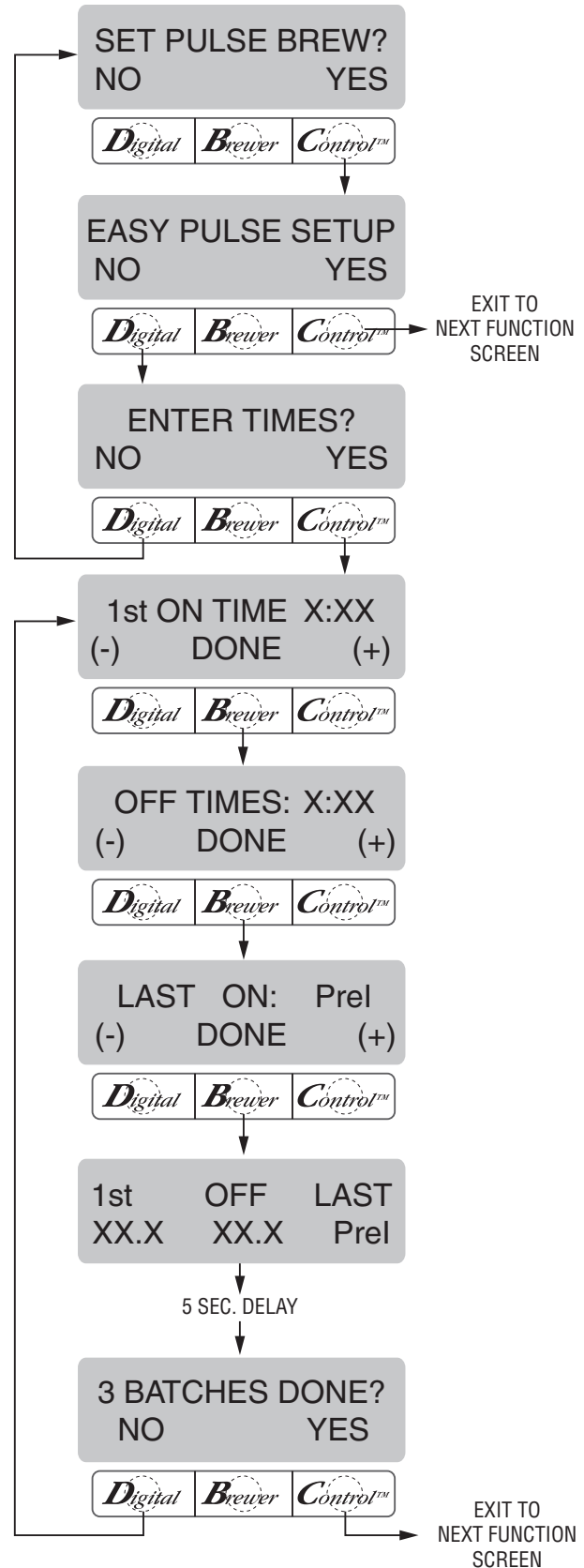

PROGRAMMING THE BREWER (cont.)

DRIP TIME (now displayed on "non" funnel lock units as well)

This function allows the setting or modification of the funnel locks to stay engaged after the end of a brew cycle. This ensures that the funnel cannot be removed until after the liquid has emptied out of the funnel.

Procedure to modify drip times:

Range: OFF to 10 minutes for all three batch sizes.

NOTE: If the brewer is already in the **DRIP TIMES** screen, it is not necessary to follow steps 1 through 9 in this section, but proceed directly to step 10.

1. Press and hold the upper right hidden switch until the display reads **UNITS**. Release the switch, then press and hold the upper right hidden switch until the display reads **REVIEW RECIPES**.
2. Press **YES** to proceed. The display should now read **NO NAME**, along with **MODIFY, SHOW** and **NEXT**.
3. Press and release **NEXT** to advance to the desired coffee name to be modified.
4. Press and release **MODIFY**. The display should read **BREW OZ**.
5. Press and release **DONE**. The display should read **3 BATCHES DONE?**
6. Press and release **YES**. The display should now read **% BYPASS**.
7. Press and release **DONE**. The display should read **3 BATCHES DONE?**
8. Press and release **YES**. The display should now read **SET PULSE BREW**.
9. Press and release **NO**. The display should now read **DRIP TIME**, along with either the word **OFF**, or a time will be showing. A batch light should also be blinking.
10. Using the **(-)** and **(+)**, set the amount of time from when the brew solenoid shuts off to when drip-out occurs for that batch size.

NOTE: Set to **OFF** to prevent funnel locks from engaging (to disable this function), for a particular batch size. To set to **OFF**, press and release **(-)** until **OFF** is displayed.

11. When finished, press another batch size and repeat step 10 until all three batches are set.
12. When finished, press **DONE**. The display should read **3 BATCHES DONE?**
13. If the three batch sizes are set correctly, press **YES**. The screen should show the name of the coffee flavor being programmed (modified) along with **SETUP COMPLETE**.
14. After a 5 second delay, the display will advance to the next coffee name in the brewer's memory. If no other coffee names are present, the display will read **THAT WAS THE LAST RECIPE**, and return to the **REVIEW RECIPES** screen.

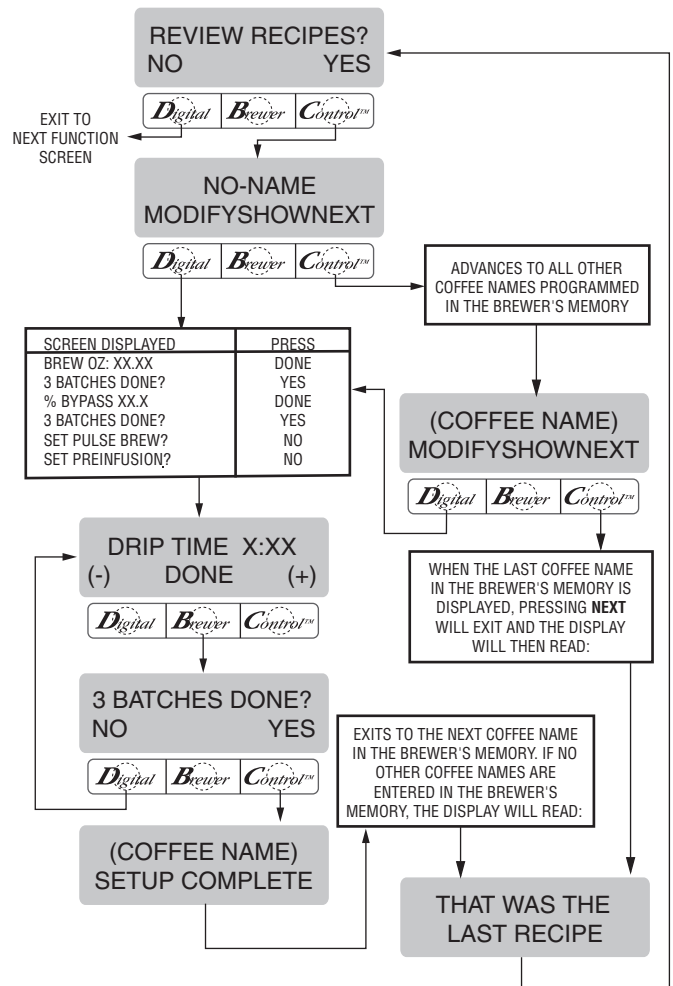

P2447

PROGRAMMING THE BREWER (cont.)

ASSIGN RECIPES

This function allows for assigning a coffee name other than **NO-NAME** to the **BREW** switch.

Procedure to assign recipes:

1. Press and hold the upper right hidden switch until the display reads **UNITS**. Release the switch, then press and release switch until the display reads **ASSIGN RECIPE ?**.
2. Press **YES** to assign a recipe to the BREW switch.
3. Use **(-)** and **(+)** to select recipe which you want to assign to the BREW switch.
4. Press and release **DONE** when selected to advance to next function screen, **ENABLE ADS**.

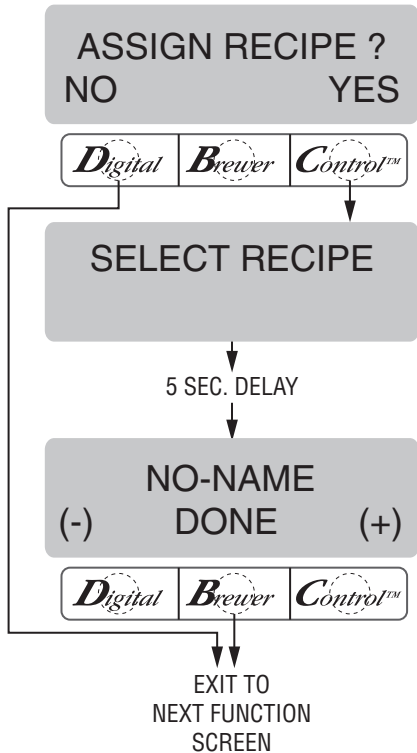

P3515

ENABLE ADS?

This function allows the operator to choose whether or not to display the advertising message that was entered into the brewer with an **AD CARD**. This message will be displayed when the brewer is not in use.



P2721

Procedure to Enable/Disable Ads:

1. Press and hold the upper right hidden switch until the display reads **UNITS**. Release the switch, then press and release switch until the display reads **ENABLE ADS**. The **YES** or **NO** will be flashing to indicate the current selection.
2. Press and release the **NO** switch to disable this function (no ads will be displayed on the screen), or;
3. Press and release the **YES** switch to enable this function (ads will be displayed on screen).
4. When finished, press and release **DONE** to save the new setting, exit the **ENABLE ADS** function and advance to the next function screen, **SET TEMP**. Another alternative is to press the ON/OFF switch located on the front switch panel to exit the **ENABLE ADS** function and return to the **MAIN SCREEN**.

Brew water temperature is factory set at 200° F (93.3° C). Areas of high altitude will require lowering this temperature to prevent boiling. This chart should be used as a guide when readjusting the brew water temperature.

Altitude (Feet)	Boiling point of water		Recommended water temperature	
	° F	° C	° F	° C
-1000	213.8	101.0	200	93.3
-500	212.9	100.5	200	93.3
0	212.0	100.0	200	93.3
500	211.1	99.5	200	93.3
1000	210.2	99.0	200	93.3
1500	209.3	98.5	200	93.3
2000	208.4	98.0	200	93.3
2500	207.4	97.4	200	93.3
3000	206.5	96.9	199	92.8
3500	205.6	96.4	198	92.2
4000	204.7	95.9	197	91.7
4500	203.8	95.4	196	91.1
5000	202.9	94.9	195	90.6
5500	201.9	94.4	195	90.6
6000	201.0	93.9	194	90.0
6500	200.1	93.4	193	89.4
7000	199.2	92.9	192	88.9
7500	198.3	92.4	191	88.3
8000	197.4	91.9	190	87.8
8500	196.5	91.4	189	87.2
9000	195.5	90.8	188	86.7
9500	194.6	90.3	187	86.1
10000	193.7	89.8	186	85.6

SET TEMP - Range: 185°F (85°C) to 205°F (96°C)

This function allows the operator to set the brew water temperature in the tank. It also sets the hot water faucet dispense temperature.

PROGRAMMING THE BREWER (cont.)

SET TEMP (cont.)



P2721

Procedure to set brew temperature:

1. Press and hold the upper right hidden switch until the display reads **UNITS**. Release the switch, then press and release switch until the display reads **SET TEMP**.
2. To adjust the brew temperature, press **(-)** to decrease or **(+)** to increase the brew temperature.
3. When finished, press and release **DONE** to save the new setting, exit the **SET TEMP** function and advance to the next function screen, **SET READY**. Another alternative is to press the ON/OFF switch located on the front switch panel to exit the **SET TEMP** function and return to the **MAIN SCREEN**.

SET READY - Range: 185°F (85°C) to 203°F (95°C)

This function allows the operator to set the minimum temperature allowable to start a brew cycle. The range can be from 185°F (85°C) to within 2°F (-1.7°C) of the **SET TEMP**. The water must be at the **SET READY** temperature or higher for the display to indicate **READY TO BREW**. If brew lockout is enabled, the brewing process will not start below this **READY** temperature.

NOTE: The upper limit is the water temperature control setting minus 2°F (-1.7°C).



P2721

Procedure to set ready temperature:

1. Press and hold the upper right hidden switch until the display reads **UNITS**. Release the switch, then press and release switch until the display reads **SET READY**.
2. To adjust the ready temperature, press the **(-)** switch to decrease, or **(+)** to increase the ready temperature.

3. When finished, press and release **DONE** to save the new setting, exit the **SET READY** function and advance to the next function screen, **REFILL**. Another alternative is to press the ON/OFF switch located on the front switch panel to exit the **SET READY** function and return to the **MAIN SCREEN**.

REFILL - Range: 20 to 230

This function allows the operator to adjust the sensitivity of the refill circuit. This is mainly a troubleshooting feature. Water in different geographical locations can have different conductivities. By adjusting the sensitivity of the refill circuit, this will allow the brewer to operate under various water conditions.



P2721

Procedure to set the sensitivity threshold of the refill circuit:

NOTE: Make sure the water in the tank is touching the refill probe.

1. Press and hold the upper right hidden switch until the display reads **UNITS**. Release the switch, then press and release switch until the display reads **REFILL** and shows a number on both sides of the word.
2. To adjust the threshold setting, press **(-)** to decrease, or **(+)** to increase the setting.
NOTE: Always make sure that the number on the right is larger than the number on the left when water is in contact with the refill probe in the tank.
3. When finished, press and release **DONE**. This saves the new setting and advances to the next function screen, **SPRAY OZ/M**. Another alternative is to press the ON/OFF switch located on the front switch panel to exit **REFILL** and return to the **MAIN SCREEN**.

SPRAY OZ/M

This function allows the operator to view or to enter the actual flow rate coming out of the sprayhead. This is **NOT** used to change the actual flow rate, but to tell the internal controller how fast the water is flowing. The unit of measure is ounces per minute. (Oz/M)

PROGRAMMING THE BREWER (cont.)

SPRAY OZ/M (cont.)



P2721

Procedure to adjust the flow rate setting:

1. Press and hold the upper right hidden switch until the display reads **UNITS**. Release the switch, then press and release switch until the display reads **SPRAY OZ/M**. The number represents what the brewer thinks is the flow rate of the sprayhead valve in ounces per minute.
2. If the actual flow rate of the sprayhead valve is known, but is different than the number on the display, use the **(-)** and **(+)** to enter the correct flow rate in ounces per minute.
3. When finished, press and release **DONE**. This saves the new setting and advances to the next function screen, **BYPASS OZ/M**. Another alternative is to press the ON/OFF switch located on the switch panel to exit **SPRAY OZ/M** function and return to the **MAIN SCREEN**.

BYPASS OZ/M

This function allows the operator to view or to enter the actual flow rate coming out of the bypass nozzle. This is **NOT** used to change the actual flow rate, but to tell the internal controller how fast the water is flowing. The unit of measure is ounces per minute.

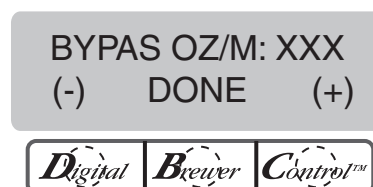

P2721

Procedure to adjust the flow rate setting:

1. Press and hold the upper right hidden switch until the display reads **UNITS**. Release the switch, then press and release switch until the display reads **BYPAS OZ/M**. The number represents what the brewer thinks is the flow rate of the bypass valve in ounces per minute.
2. If the actual flow rate of the bypass valve is known, but is different than the number on the display, use the **(-)** and **(+)** to enter the correct flow rate in ounces per minute.

3. When finished, press and release **DONE**. This saves the new setting and advances to the next function screen, **CALIBRATE FLOW**. Another alternative is to press the ON/OFF switch located on the front switch panel to exit the **BYPASS OZ/M** function and return to the **MAIN SCREEN**.

CALIBRATE FLOW

This function allows the operator to enter the actual flow rate of the sprayhead and the bypass by dispensing both separately for one minute. The volumes are then entered in ounces per minute. (Oz/M)

Procedures to calibrate the sprayhead flow rate:

1. Place a container, accurately graduated in ounces, and with a minimum capacity of 60 ounces, beneath the funnel on the brewer.
2. Press and hold the upper right hidden switch until the display reads **UNITS**. Release the switch, then press and release switch until the display reads **CALIBRATE FLOW**.
3. Press and release **YES** to advance to the **SPRAY-HEAD CAL?** function screen. (Pressing **NO** in the **CALIBRATE FLOW** screen will advance to the next function screen, **BREW COUNTERS**).
4. Press and release the **YES** pad. The display should read **CONTAINER READY?** If the container is under the funnel, press **YES**. The display should read **CALIBRATE SPRAY .. PRESS BREW TO START**.
5. Press and release the BREW switch. The display should read **CALIBRATE SPRAY .. 60 SEC TO FINISH**. The 60 second timer on the display will count down to zero. When the counter reaches zero, the display will change to **ENTER OZ.**, along with a number measured in ounces per minute.
6. Measure the amount of water in the container and using the **(-)** or **(+)**, adjust the amount on the display to match the amount in the container. Then press **DONE**.
7. The display should now read **NEW SPRAY FLOW**, along with the correct flow rate of the sprayhead in ounces per minute. After about 5 seconds, the display will return to the **CALIBRATE FLOW** screen.
8. To exit the **CALIBRATE FLOW** program, press **NO** to advance to the next function screen, or press the ON/OFF switch located on the front switch panel to exit the **CALIBRATE FLOW** function and return to the **MAIN SCREEN**.

PROGRAMMING THE BREWER (cont.)

CALIBRATE FLOW (cont.)

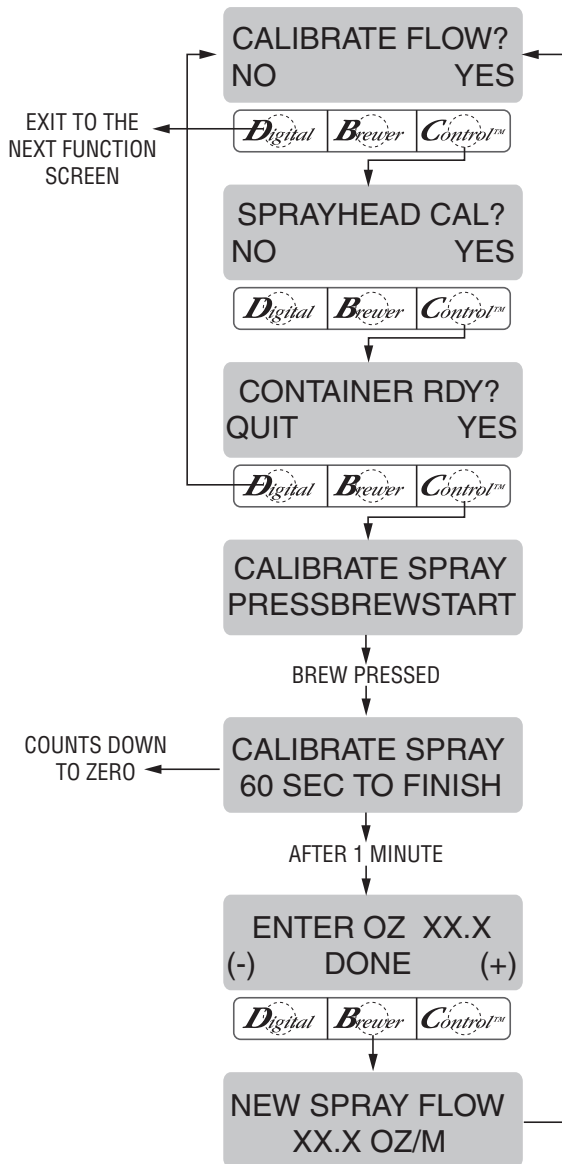

P2307

Procedures to calibrate the bypass flow rate:

1. Place a container, accurately graduated in ounces, and with a minimum capacity of 60 ounces, below the funnel on the brewer.
2. Press and hold the upper right hidden switch until the display reads **UNITS**. Release the switch, then press and release switch until the display reads **CALIBRATE FLOW**.
3. Press and release **YES** to advance to the **SPRAYHEAD CAL?** function screen. (Pressing **NO** in the **CALIBRATE FLOW** screen will advance to the next function screen, **BREW COUNTERS**).
4. Press and release **NO** to advance to the **BYPASS CALIBRATION** screen.

5. Press and release the **YES** pad. The display should read **CONTAINER READY?** If the container is under the funnel, press **YES**. The display should read **CALIBRATE BYPASS .. PRESS BREW TO START**.
6. Press and release the BREW switch. The display should read **CALIBRATE BYPASS .. 60 SEC TO FINISH**. The 60 second timer on the display will count down to zero. When the counter reaches zero, the display will change to **ENTER OZ.**, along with a number measured in ounces per minute.

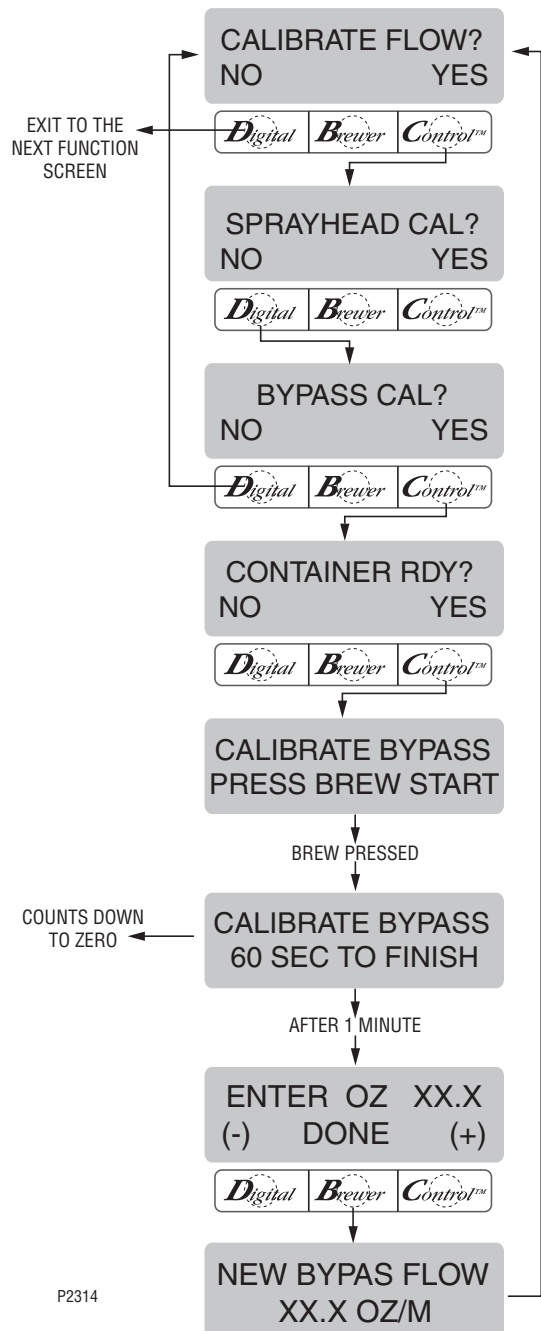

P2314

PROGRAMMING THE BREWER (cont.)

CALIBRATE FLOW (cont.)

7. Measure the amount of water in the container, and using (-) or (+), adjust the amount on the display to match the amount in the container. Then press **DONE**.
8. The display should now read **NEW BYPASS FLOW**, along with the correct flow rate of the bypass in ounces per minute. After about 5 seconds, the display will return to the **CALIBRATE FLOW** screen.
9. To exit the **CALIBRATE FLOW** function, press and release **NO** to advance to the next function screen, or press the ON/OFF switch located on the front switch panel to exit the **CALIBRATE FLOW** function and return to the **MAIN SCREEN**.

BREW COUNTERS

This function allows the operator to track the number of brew cycles completed. There is one resettable counter, and one life counter that is not resettable.

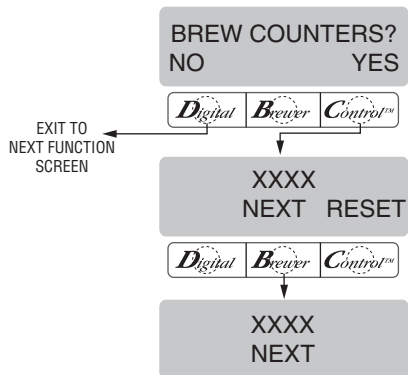

P2448

Procedures to view/reset the brew counters:

1. Press and hold the upper right hidden switch until the display reads **UNITS**. Release the switch, then press and release switch until the display reads **BREW COUNTERS**.
2. Pressing **NO** in this screen will advance to the next function. Press **YES** to view the first brew counter. This number represents the brew cycles initiated since that counter was last reset.
3. To reset the resettable counter to zero press and release **RESET** when viewing that particular counter's screen.

4. To advance to the other counter, press and release **NEXT**. This will advance to total brews (non-resettable).
5. When finished, press **NEXT** until the display reads **BREW COUNTERS**. Press and release **NO** to advance to the next function screen, or press the ON/OFF switch located on the front switch panel to exit the **BREW COUNTERS** function and return to the **MAIN SCREEN**.

FUNNEL DETECT (optional)

This function allows the operator to prevent the start of a brew cycle if a Smart Funnel is not positioned correctly in the funnel rails.



P2721

Procedure to set funnel detect:

1. Press and hold the upper right hidden switch until the display reads **UNITS**. Release the switch, then press and release switch until the display reads **FUNNEL DETECT**.
2. **NO** or **YES** should be flashing to indicate the current setting.
3. Select **YES** to prevent brewing if a Smart Funnel is not correctly situated in the rails. If this function is activated and a brew cycle is attempted with the funnel not properly situated, the display will read, **FUNNEL NOT IN PLACE**, until one is in place.
4. Select **NO** to allow brewing without a Smart Funnel in place. This is selected when brewing with a funnel other than a Smart Funnel (a regular brew funnel).
5. When finished, press and release **DONE**. This will retain the changes, exit this function screen and advance to the next. Another alternative is to press the ON/OFF switch located on the front switch panel to exit the **FUNNEL DETECT** and return to the **MAIN SCREEN**.

PROGRAMMING THE BREWER (cont.)

SERVICE TOOLS

This function allows the testing of individual components and the ability to check switches for proper function. This function also tests the Soft Heat server's status on the brewer (in place or removed), and the funnel sensor coil's frequency (diagnostic tool for troubleshooting purposes only).

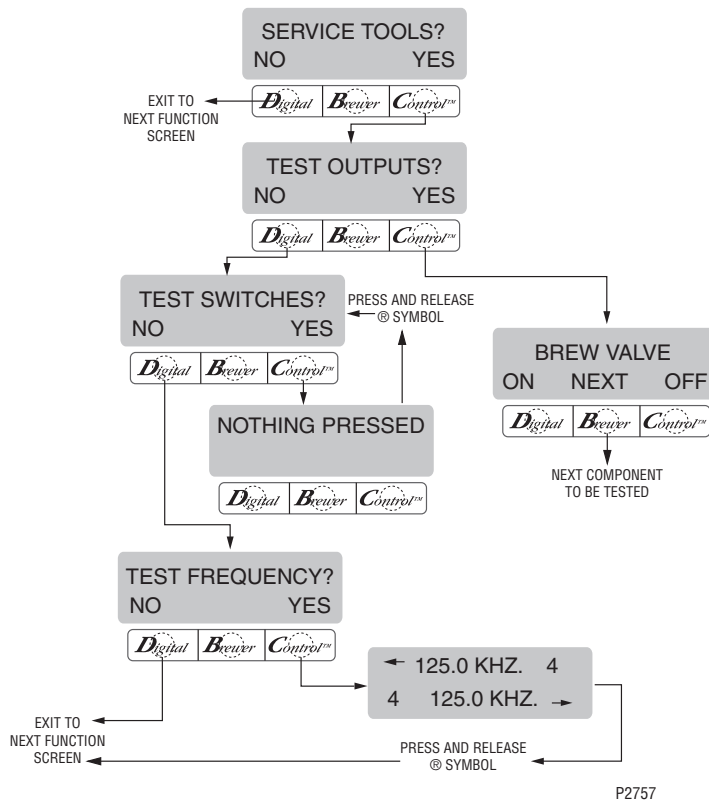

Testing individual components (outputs):

This will allow the operator to test the operation of individual components and outputs of the brewer. The components that can be individually tested are as follows:

Brew Valve
Bypass Valve
Funnel Lock (Optional)
Refill Valve
Tank Heaters
Heater Contactor

Procedure to test components (outputs):

1. Place brew funnels into rails on the brewer.
2. Place a Soft Heat server beneath the brew funnel.
3. Press and hold the upper right hidden switch until the display reads **UNITS**. Release the switch, then press and release switch until the display reads **SERVICE TOOLS**.
4. Press **YES** to run tests on various components and outputs within the brewer. Pressing **NO** will exit this function and advance to the next function screen.
5. The display should read **TEST OUTPUTS**.
6. Press and release **YES**. The display should read **BREW VALVE**.
7. To test **BREW VALVE**, press **ON**. If the brew valve is functional, water should run from the brewer.
8. Press **OFF** to end flow of water.
9. Press **NEXT** to advance to the next component to be tested.

NOTE: To bypass testing any component, press **NEXT** to advance to the next one, without testing the previous component.

10. To test **BREW BYPASS**, press **ON**. If the bypass valve is functional, water should run from the brew bypass.
11. Press **OFF** to end flow of water.
12. Press **NEXT** to advance to the next component to be tested.
13. To test **FUNNEL LOCK**, press **ON**. If the funnel lock is functional, the lock will come down to hold the funnel in place.

PROGRAMMING THE BREWER (cont.)

SERVICE TOOLS (cont.)

14. Press **OFF** to retract the funnel lock.
15. Press **NEXT** to advance to the next component to be tested.
16. To test **REFILL VALVE**, press **ON**. If the refill valve is functional, the sound of the valve operating will be heard.
17. Press **OFF** to end testing of refill valve.
18. Press **NEXT** to advance to the next component to be tested.
19. To test **TANK HEATER**, connect a voltmeter across the tank heater to check for voltage.
20. Press **ON**. The correct voltage should be present at the heater terminals.
21. Press **OFF** to end testing of the tank heater.

NOTE: The tank heater will automatically turn off if left on too long.

22. After testing the tank heater, press **NEXT** to advance to the next test.
23. The **HEATER CONTACTOR** is used only on certain models. Check the machine schematic to see if the contactor is present. Connect a voltmeter across the tank heater and press **ON** to check that correct voltage is present. Press **OFF** and confirm the voltage is zero.
24. Press **NEXT** to return to **TEST OUTPUTS**.
25. To exit **SERVICE TOOLS**, press and release the ON/OFF switch located on the front switch panel. This will return to the **MAIN SCREEN**.

Procedure to test switches:

This function allows the operator to test the operation of the individual switches on the front panel.

1. Place brew funnel into rails on the brewer.
2. Place a server beneath the brew funnel.
3. Press and hold the upper right hidden switch until the display reads **UNITS**. Release the switch, then press and release switch until the display reads **SERVICE TOOLS**.
4. Press **YES** to run tests on various components and outputs within the brewer. (Pressing **NO** will exit this function and advance to the next function screen.)
5. The display should read **TEST OUTPUTS**.
6. In **TEST OUTPUTS** screen, press **NO**. This advances

to **TEST SWITCHES**.

7. Pressing **NO** in this screen will advance to the next function. Press **YES** in the **TEST SWITCHES** screen to test the switches. The display will read **NOTHING PRESSED**.
8. From this screen, press any of the switches on the front of the brewer. While the switch is pressed, the display shows the name of that switch. If the name does not appear, or if it remains after the switch has been released, the switch is defective. Each switch can be tested in this manner.
9. After all switches have been tested, press the upper right hidden switch located on the front switch panel. This will exit **TEST SWITCHES** and return to the **MAIN SCREEN**.

Procedures to test coil frequency:

1. Place brew funnel into rails of the brewer.
2. Place a server beneath the brew funnel.
3. Press and hold the upper right hidden switch until the display reads **UNITS**. Release the switch, then press and release switch until the display reads **SERVICE TOOLS**.
4. Pressing **NO** will exit this function and advance to the next function screen. Press **YES** to run tests on various components and outputs within the brewer.
5. The display should read **TEST OUTPUTS**.
6. In **TEST OUTPUTS** screen, press **NO**. Continue to press and release **NO** until the display reads **TEST FREQUENCY**.
7. Press and release **YES**. The display will show the frequency of the sensor coil circuits. This is for diagnostic service use when troubleshooting this circuit.
8. After the coils have been tested, press and release the ON/OFF switch located on the front switch panel. This will exit the **TEST FREQUENCY** function and return to the **MAIN SCREEN**.

NOTE: If the operator wishes to test more than one function in the **SERVICE TOOLS** section (outputs, switches, servers, or coil frequency), it is not necessary to exit the program. Use the flow chart for **SERVICE TOOLS** to navigate to a particular function.

PROGRAMMING THE BREWER (cont.)

FACTORY DEFAULTS

This function allows the operator to erase **all** of the previously entered recipes and ad messages. Factory-set default values will replace **all** previous settings.

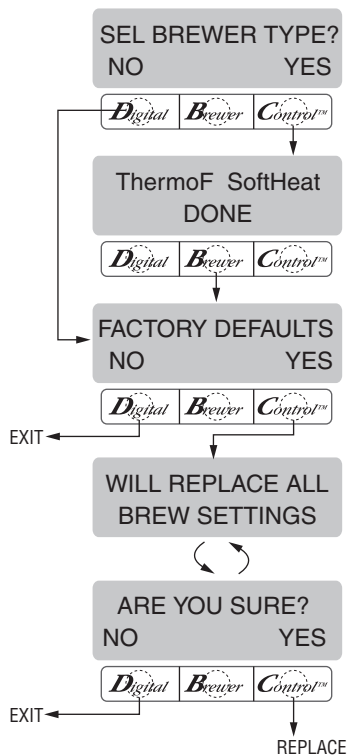

P2312

Procedure to set factory defaults:

1. Press and hold the upper right hidden switch until **UNITS** appears. Release the switch. Press and release the upper right hidden switch until the display reads **SEL BREWER TYPE?**.
2. Pressing **NO** in this screen will advance to **FACTORY DEFAULTS**. Press and release **YES**. The display should read **ThermoF SoftHeat**. The selected brewer type will be flashing. When correct brewer type is selected press **DONE**.
3. The display should now read **FACTORY DEFAULTS**. Pressing **NO** in this screen will revert to the **MAIN SCREEN**. Press **YES** to replace the defaults. This advances to **WILL REPLACE ALL BREWING SETTINGS**. This screen will alternate with **ARE YOU SURE?**.
4. Pressing **NO** in the confirmation screen will revert to **MAIN SCREEN**, without resetting the brewing setups to the defaults. Press **YES** to load the defaults. This will then revert to the **MAIN SCREEN**, and the factory default values will replace **all** previously entered values. It will NOT reset the summation Brew counter.

TROUBLESHOOTING

A troubleshooting guide is provided to suggest probable causes and remedies for the most likely problems encountered. If the problem remains after exhausting the troubleshooting steps, contact the Bunn-O-Matic Technical Service Department.

- Inspection, testing, and repair of electrical equipment should be performed only by qualified service personnel.
- All electronic components have 120 - 240 volt ac and low voltage dc potential on their terminals. Shorting of terminals or the application of external voltages may result in board failure.
- Intermittent operation of electronic circuit boards is unlikely. Board failure will normally be permanent. If an intermittent condition is encountered, the cause will likely be a switch contact or a loose connection at a terminal or crimp.
- Solenoid removal requires interrupting the water supply to the valve. Damage may result if solenoids are energized for more than ten minutes without a supply of water.
- The use of two wrenches is recommended whenever plumbing fittings are tightened or loosened. This will help avoid twists and kinks in the tubing.
- Make certain that all plumbing connections are sealed and electrical connections tight and isolated.
- This brewer is heated at all times. Keep away from combustibles.

WARNING

- Exercise extreme caution when servicing electrical equipment.
- Disconnect the brewer from the power source when servicing, except when electrical tests are specified.
- Follow recommended service procedures.
- Replace all protective shields or safety notices.

Screen Displayed

Possible Cause

Troubleshooting Procedures

OVERFLOW CUP
FULL. EMPTY CUP

1. 1. Overflow cup is full of water. This could be caused by boiling; see chart on page 32. Also could be Refill Sensitivity adjustment; see page 33.

Empty cup. Correct cause and retry.

NO FUNNEL
PRESENT

1. **SMART FUNNEL** not fully inserted into the funnel rails.

Position the funnel so that the sensor is directly beneath the sensor coil on the brewer.

2. Not using a **SMART FUNNEL**, and the **FUNNEL DETECT** function is activated (on).

Disable the **FUNNEL DETECT** function.

TROUBLESHOOTING (cont.)

Screen Displayed

TEMPERATURE
TOO LOW

Possible Cause

1. Water temperature in the tank does not meet the **SET READY TEMPERATURE**.

Troubleshooting Procedures

(a) Wait for the brewer to heat to the proper temperature.

(b) Disable the **BREW LOCKOUT** function.

CHECK FUNNEL
FOR FRESH COFFEE

1. Brew funnel was not removed after the previous brew cycle was finished.

Remove funnel, check contents, and insert back into the funnel rails.

OR

PRESS BREW
TO BREW ANYWAY

Press **BREW** to start a brew cycle without removing the funnel.

BREW STOPPED!
FUNNEL REMOVED?

1. Brew funnel was moved out of position after the brew cycle was started.

To resume brewing, correctly position the funnel and press **BREW** again. The brew cycle will resume from the point it was interrupted.

OR

TO FINISH:
PRESS BREW

Press **ON/OFF** to terminate the cycle.

TO CANCEL
PRESS ON/OFF

TROUBLESHOOTING (cont.)

Screen Displayed

BREW STOPPED!
IS SWITCH OFF?



TO FINISH:
PRESS BREW



TO CANCEL
PRESS ON/OFF

HEATING TIME
TOO LONG



CHECK HEATING
CIRCUIT

Possible Cause

1. **ON/OFF** switch was pressed after the brew cycle was started.

Troubleshooting Procedures

To resume brewing, press **BREW** again. The brew cycle resumes from the point it was interrupted.

OR

Press **ON/OFF** to terminate the brew cycle.

1. Tank Heater failure

Service Required

2. Triac Failure

Service Required

3. Control Board/Thermistor failure

Service Required

TROUBLESHOOTING (cont.)

Screen Displayed

FILL TIME TOO
LONG



CHECK WATER
SUPPLY

Possible Cause

1. Water shut off to brewer
2. Inlet Solenoid Valve failure
3. Control Board Failure

Troubleshooting Procedures

- Check water supply shut-off
- Service required
- Service required

TEMP SENSOR
OUT OF RANGE



CHECK FOR BAD
CONNECTIONS

1. Temperature Sensor Probe wire(s) broken or not making connection.

Check wire and connection of both black and white wires of temperature probe.

TEMP SENSOR
OUT OF RANGE



CHECK WIRE FOR
SHORTS

1. Temperature Sensor Probe wire(s) shorted to housing, or to each other.

Check to confirm that wire(s) are not pinched between two surfaces or connected to each other.

TROUBLESHOOTING (cont.)

Problem	Possible Cause	Troubleshooting Procedure
Equipment will not operate.	1. No power or incorrect voltage.	Measure the voltage at the terminal block and confirm that it matches the voltage specified on the brewer data plate within +/- 10%.
Brew cycle will not start.	1. No water 2. ON/OFF switch 3. Brew switch 4. Brew Valve 5. Electronic Control Board	Check plumbing and shut-off valves Test the ON/OFF switch. Refer to the switch test procedures. Test the BREW switch. Refer to the switch test procedures. Test the Brew valve. Refer to <i>Testing Individual Components</i> . Substitute a control board known to be in good working order.
Automatic refill will not operate or display shows FILL TIME TOO LONG	1. No water 2. Water strainer	Check plumbing and shut-off valves. (A) Direction of flow arrow must be pointing towards direction of water flow. (B) Remove the strainer and check for obstructions. Clear or replace

TROUBLESHOOTING (cont.)

Problem

Automatic refill will not operate or display shows FILL TIME TOO LONG (cont.)

Possible Cause

3. Refill Probe or Sensitivity Setting

Troubleshooting Procedure

Check the sensitivity setting. Refer to the *Refill* function. If the left three digit number is less than the right number, the machine “thinks” it is full and the refill valve should be off. If the left number is larger than the right, then the refill valve will automatically be turned on to fill the tank. The right number is the threshold setting and can be adjusted to compensate for extreme water conditions: very pure, low conductance water requires a higher setting, while high mineral content, high conductance water requires a lower setting. Note that the left number changes from a high value when water is NOT touching the refill probe to a low value when water IS touching the probe. For best operation, the right number should be set to a value midway between these low and high numbers. Before changing the setting, confirm that the refill probe is free of scale buildup and the connection to it is secure.

4. Refill Valve

Test the Refill valve. Refer to *Testing Individual Components*.

5. Overflow Protection Switch

When this condition occurs, the brewer will display OVERFLOW CUP FULL. EMPTY CUP. The reason for overfilling could be a defective refill valve, an incorrect sensitivity setting, (see above) or boiling.

6. Electronic Control Board

Substitute a control board known to be in good working order.

Water flows into tank continuously with power removed from brewer.

1. Refill valve

Foreign material lodged in valve, holding it in open state.

TROUBLESHOOTING (cont.)

Problem

Water flows into tank continuously with power applied to brewer.

Possible Cause

1. Refill Probe or Sensitivity Setting

Troubleshooting Procedures

Check the sensitivity setting. Refer to the *Refill* function. If the left three digit number is less than the right number, the machine “thinks” it is full and the refill valve should be off. If the left number is larger than the right, then the refill valve will automatically be turned on to fill the tank. The right number is the threshold setting and can be adjusted to compensate for extreme water conditions: very pure, low conductance water requires a higher setting, while high mineral content, high conductance water requires a lower setting. Note that the left number changes from a high value when water is NOT touching the refill probe to a low value when water IS touching the probe. For best operation, the right number should be set to a value midway between these low and high numbers. Before changing the setting, confirm that the refill probe is free of scale buildup and the connection to it is secure.

2. Electronic Control Board

Substitute a control board known to be in good working order.

Water will not heat or display shows HEATING TIME TOO LONG

1. Limit Thermostat

CAUTION - Do not eliminate or bypass limit thermostat. Use only replacement part #23717.0001.

Remove power from the brewer. Press reset button on limit thermostat. Then check for continuity through it.

2. Tank Heaters

Remove power from the brewer. Check for continuity through the tank heaters.

TROUBLESHOOTING (cont.)

Problem

Water will not heat or display shows
HEATING TIME TOO LONG (cont.)

Possible Cause

3. Triac

4. Electronic Control Board

Troubleshooting Procedures

Remove power from the brewer. Connect a voltmeter across one of the tank heaters. Reapply power to the brewer and refer to *Testing Individual Components*. If the full supply voltage is measured when the tank heater is turned on, and zero voltage is measured with the triac off, then the triac is good. If half the supply voltage is measured, the triac is defective. If very low, or zero voltage is measured, there could be a defective triac or a defective control board.

Perform the above procedure for testing triacs. If the voltage measured is very low or zero, then substitute a control board known to be in good working order.

Spitting or unusual steaming from
sprayhead or air vent. (Water too
hot)

1. Triac

2. Lime Buildup

CAUTION - Tank and tank components should be delimed regularly depending on local water conditions. Excessive mineral buildup on stainless steel surfaces can initiate corrosive reactions resulting in serious leaks.

Remove power from the brewer. Connect a voltmeter across one of the tank heaters. Reapply power to the brewer and refer to *Testing Individual Components*. If the full supply voltage is measured when the tank heater is turned on, and zero voltage is measured with the triac off, then the triac is good. If half the supply voltage is measured, the triac is defective. If very low, or zero voltage is measured, there could be a defective triac or a defective control board.

Inspect the tank assembly for excessive lime deposits. Delime as required.

TROUBLESHOOTING (cont.)

Problem	Possible Cause	Troubleshooting Procedures
Spitting or unusual steaming from sprayhead or air vents. (Water too hot) (cont.)	3. Electronic control board	Perform the previous procedure for testing triacs. If the voltage measured is very low or zero, then substitute a control board known to be in good working order.
Inconsistent beverage level in server.	1. Strainer	(A) Direction of flow arrow must be pointing towards the brewer. (B) Remove the strainer and check for obstructions. Clear or replace.
	2. Improper water pressure	Check operating water pressure to the brewer. It must be between 20 and 90 psi (138 and 620 kPa).
	3. Brew Valve	Test the Brew Valve. Refer to <i>Testing Individual Components</i> . Turn the valve on for 30 seconds and collect the water dispensed from the sprayhead. Repeat the test several times to confirm a consistent volume of dispensed water. If not consistent, check the valve, tubing and sprayhead for lime buildup.
	4. Bypass Valve	If bypass is being used on the inconsistent brewing recipe, test the Bypass Valve. Refer to <i>Testing Individual Components</i> . Turn the valve on for 30 seconds and collect the water collected from the bypass opening. Repeat the test several times to confirm a consistent volume of dispensed water. If not consistent, check the valve, tubing and bypass opening for lime buildup.
	5. Lime buildup	Inspect for lime buildup that could block the tank, tank fittings, tubing, valves and sprayhead.

TROUBLESHOOTING (cont.)

Problem	Possible Cause	Troubleshooting Procedures
Consistently high or low beverage level in server.	1. Brew Volume adjustment	Adjust the brew volume as required to achieve the recommended volume for each brew cycle.
Dripping from sprayhead.	1. Brew Valve	Repair or replace leaky valve.
Water overflows filter.	1. Type of paper filters	BUNN paper filters should be used for proper extraction.
	2. No sprayhead	Check sprayhead
Beverage overflows server.	1. Beverage left in server from previous brew	The brew cycle should be started only with an empty server under the funnel.
	2. Brew Volume adjustment	Adjust the brew volume as required to achieve the recommended volume for each brew cycle.
Weak beverage.	1. Type of paper filters	BUNN paper filters should be used for proper extraction.
	2. Coffee	A sufficient quantity of fresh drip or regular grind should be used for proper extraction.
	3. Sprayhead	B.O.M. sprayhead should be used to properly wet the bed of ground coffee in the funnel.
	4. Funnel Loading	The BUNN paper filter should be centered in the funnel and the bed of ground coffee leveled by gentle shaking.
	5. Water temperature	Empty the server, remove its cover, and place the server beneath the sprayhead. Place empty funnel over the server entrance, with ON/OFF switch in the "ON" position press the Brew switch and release it. Check the water temperature immediately below the sprayhead with a thermometer. The reading should not be less than 195°F (91°C).

TROUBLESHOOTING (cont.)

Problem	Possible Cause	Troubleshooting Procedures
Weak beverage (cont.)	6. Incorrect Recipe	Consider adjusting bypass percentage, preinfusion, or pulse brew. Contact Bunn-O-Matic for suggestions.
Brewer is making unusual noises.	1. Solenoid (Inlet)	The nut on back of the solenoid must be tight or it will vibrate during operation
	2. Plumbing lines	Plumbing lines should not be resting on the counter top.
	3. Water Supply	(A) The brewer must be connected to a cold water line. (B) Water pressure to the brewer must not be higher than 90 psi (620 kPa). Install a regulator if necessary to lower the working pressure to approximately 50 psi (345 kPa).
	4. Tank Heaters.	Remove and clean lime off tank heaters.

SCHEMATIC WIRING DIAGRAM SINGLE TF DBC

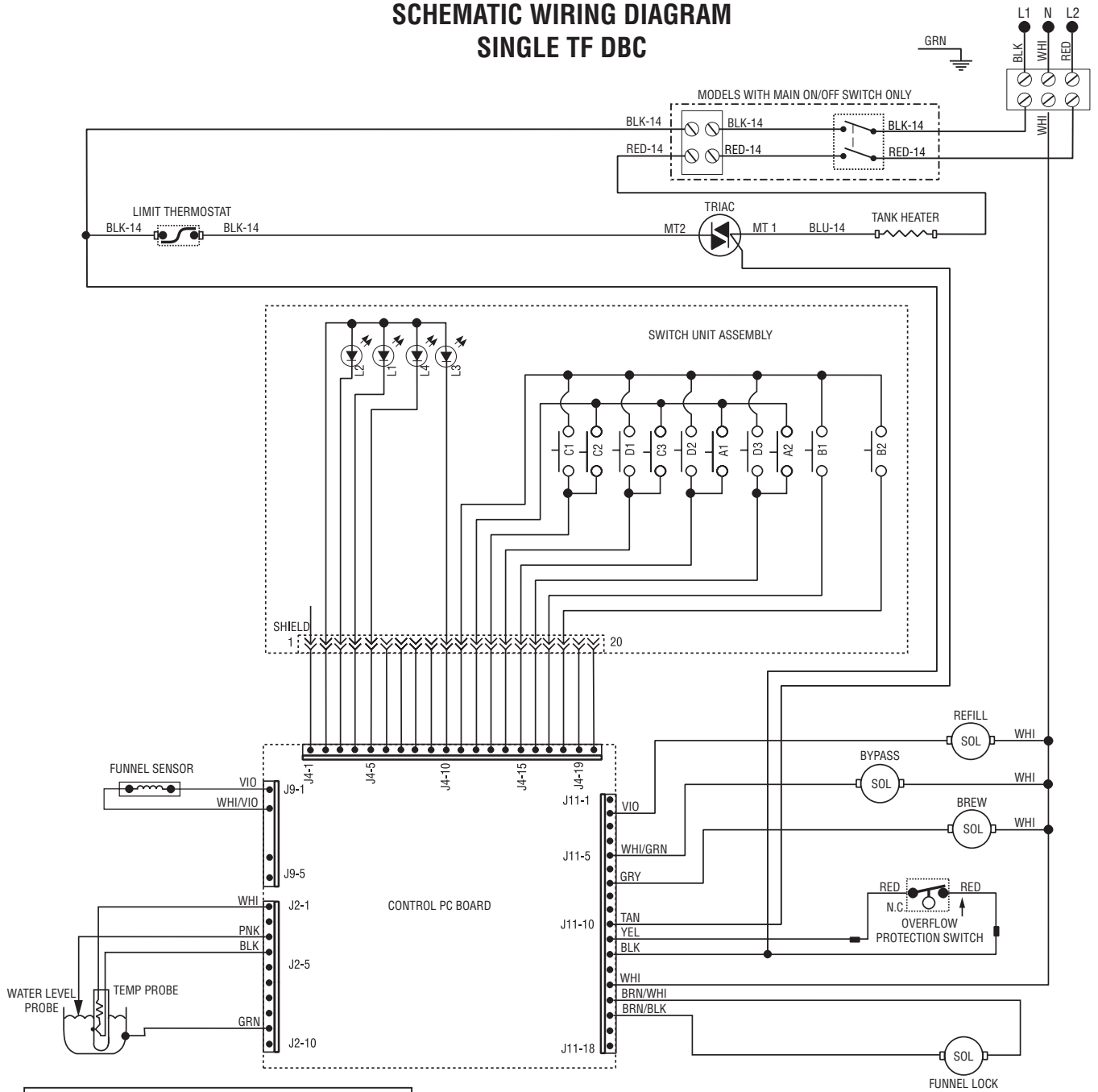

Switch Unit Assembly Codes			
A1	Brew	C2	Medium Batch
A2	On/Off	C3	Small Batch
B1	"Hidden" Left	D1	"Digital" Left Hidden Button
B2	"Hidden" Right	D2	"Brewer" Center Hidden Button
C1	Large Batch	D3	"Control" Right Hidden Button
LED's			
L1	Large Batch LED		
L2	Medium Batch LED		
L3	Small Batch LED		
L4	On/Off LED		

**120/208 OR 120/240 VOLT A.C.
3 WIRE + GND
SINGLE PHASE**

SCHEMATIC WIRING DIAGRAM SINGLE TF DBC

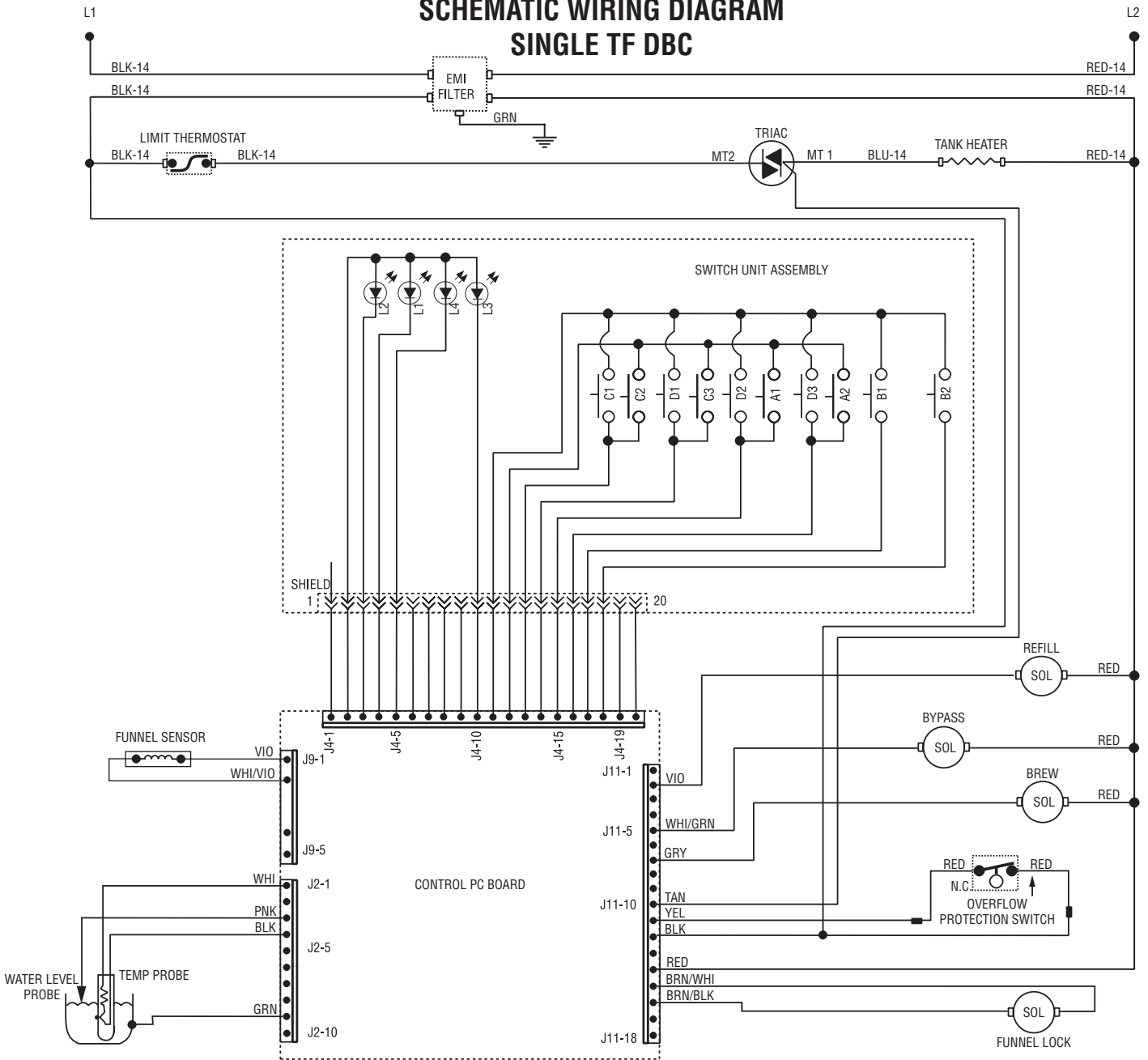

Switch Unit Assembly Codes			
A1	Brew	C2	Medium Batch
A2	On/Off	C3	Small Batch
B1	"Hidden" Left	D1	"Digital" Left Hidden Button
B2	"Hidden" Right	D2	"Brewer" Center Hidden Button
C1	Large Batch	D3	"Control" Right Hidden Button
LED's			
	L1		Large Batch LED
	L2		Medium Batch LED
	L3		Small Batch LED
	L4		On/Off LED

**230 OR 200
VOLT A.C.
SINGLE PHASE**

SCHEMATIC WIRING DIAGRAM SINGLE TF DBC

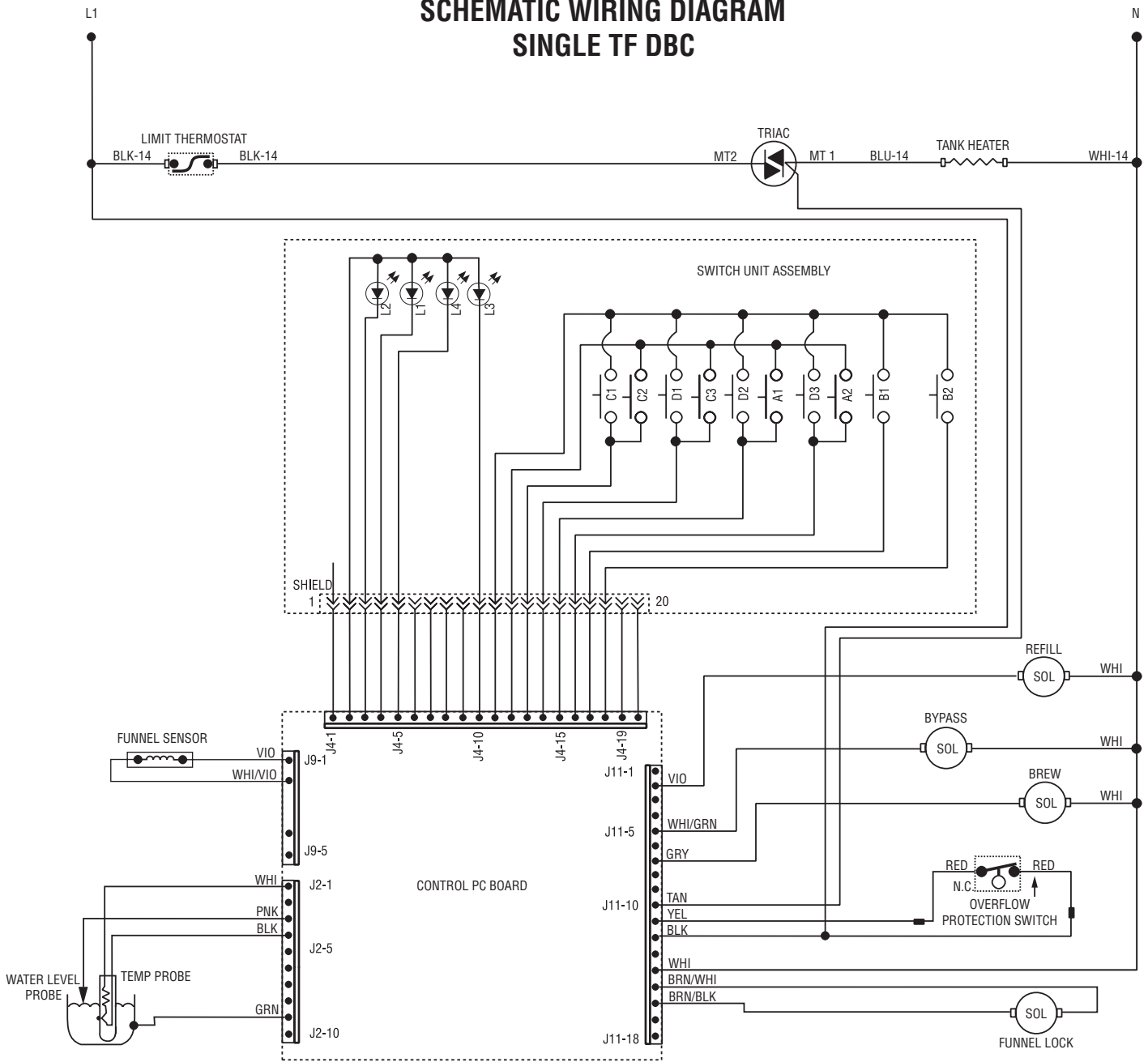

Switch Unit Assembly Codes			
A1	Brew	C2	Medium Batch
A2	On/Off	C3	Small Batch
B1	"Hidden" Left	D1	"Digital" Left Hidden Button
B2	"Hidden" Right	D2	"Brewer" Center Hidden Button
C1	Large Batch	D3	"Control" Right Hidden Button
LED's			
L1	Large Batch LED		
L2	Medium Batch LED		
L3	Small Batch LED		
L4	On/Off LED		

**120 VOLT A.C.
2 WIRE SINGLE PHASE
60HZ**

SCHEMATIC WIRING DIAGRAM SINGLE TF DBC

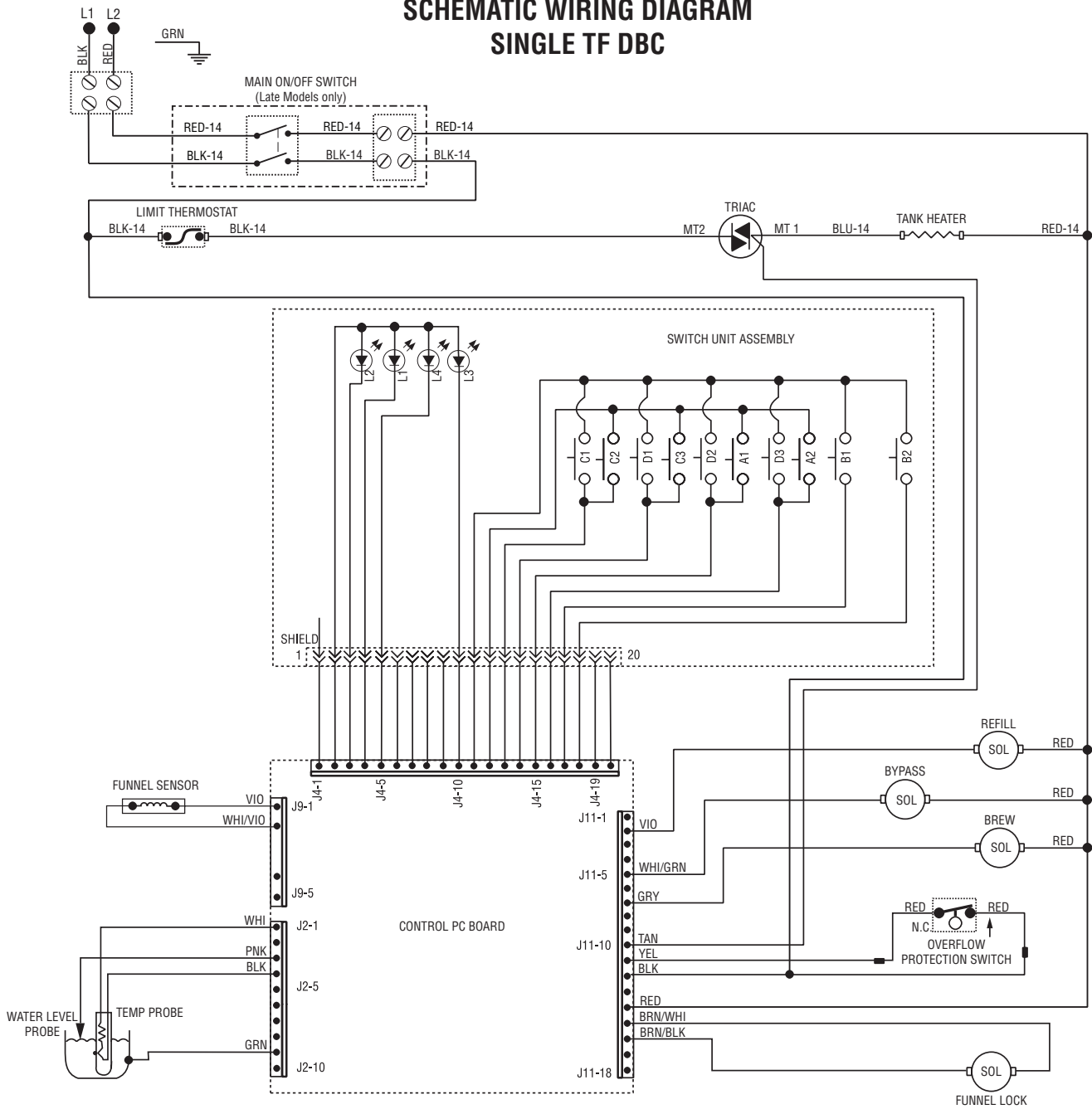

Switch Unit Assembly Codes			
A1	Brew	C2	Medium Batch
A2	On/Off	C3	Small Batch
B1	"Hidden" Left	D1	"Digital" Left Hidden Button
B2	"Hidden" Right	D2	"Brewer" Center Hidden Button
C1	Large Batch	D3	"Control" Right Hidden Button
LED's			
L1	Large Batch LED		
L2	Medium Batch LED		
L3	Small Batch LED		
L4	On/Off LED		

200, 208 or 240 VOLT A.C.
2 WIRE + GND
SINGLE PHASE 50/60HZ