

# BUNN®

## TDR-3

## TDR-5

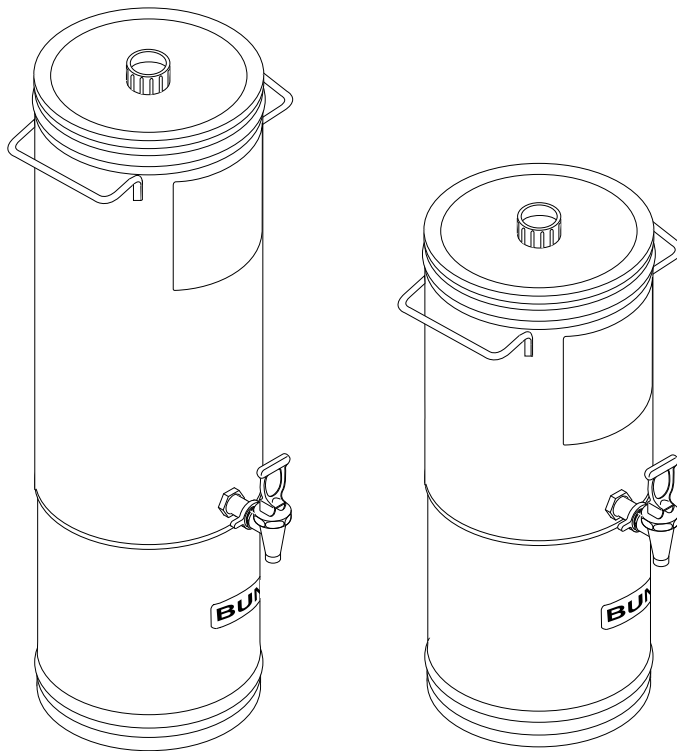

## USE & CARE INFORMATION

### INTRODUCTION

These dispensers are designed to hold and serve either a three or five gallon batch of iced tea or iced coffee, depending on the model. When proper precautions are followed, tea/coffee may be brewed directly into the dispenser and then transported to a remote serving location. The dispenser must be placed on a sturdy counter or shelf.

**NOTE** - The TDR3 dispenser weighs approximately 40 pounds when full. The TDR5 weighs approximately 55 pounds when full. **You must be careful when lifting these dispensers.**

### REPLACEMENT PARTS

- |               |                               |                |  |
|---------------|-------------------------------|----------------|--|
| 1. 03043.0002 | Decal, Fresh Brewed Tea       | 8. 24733.0006  | O-Ring 70-EP-112 (2)                     |
| 2. 00674.0000 | Faucet Cleaning Brush         | 9. 03093.0002  | Faucet Wing Nut                          |
| 3. 29720.0000 | Lid, Tea Reservoir - TDR 3    | 10. 01221.0000 | C-Ring, Faucet Shank                     |
| 4. 00651.0000 | Decal, Bunn                   | 11. 26685.0000 | Faucet Assy (Includes items 12, 13 & 14) |
| 5. 27294.0000 | Decal, Cleaning               | 12. 26884.0000 | Handle                                   |
| 6. 32224.0000 | Nut, Faucet Shank - TDR       | 13. 00601.0000 | Faucet Spring                            |
| 7. 32223.0000 | Fitting, Faucet Shank - TDR 3 | 14. 00600.0000 | Faucet Seat Cup                          |

## BUNN-O-MATIC CORPORATION

POST OFFICE BOX 3227

SPRINGFIELD, ILLINOIS 62708-3227

PHONE: (217) 529-6601 FAX: (217) 529-6644

## DAILY CLEANING

### **CAUTION - CLEAN AND SANITIZE YOUR DISPENSER DAILY**

1. Thoroughly clean the inner surfaces of the dispenser using a mild cleaner/sanitizer and water solution then thoroughly rinse the dispenser with warm water.

**NOTE** - Bunn-O-Matic recommends the use of KAY-5® for this purpose. (Kay-5 is a product of the Kay Chemical Company, Greensboro, NC) Simply pour the cleaner/sanitizer into an empty dispenser. Run a complete brew cycle of just water into the dispenser and let it set for a minute. Empty the dispenser and thoroughly rinse with warm water.

2. Remove the faucet handle/stem assembly by unscrewing the faucet bonnet just beneath the faucet handle. Use the enclosed cleaning brush to thoroughly clean the inside of the faucet and the faucet shank from inside the dispenser.

3. Disassemble the faucet/stem assembly. The faucet cleaning procedure requires a 3-compartment sink. Thoroughly wash all faucet parts in a mild detergent and water solution in the first sink. Rinse the parts in hot water in the second sink. Sanitize the parts for one minute in 75°F warm chlorine solution (at least 50 ppm) in the third sink. Reassemble the faucet and attach it to the dispenser.

4. Wash the entire outside surface of the dispenser with a clean damp cloth.

### **CAUTION - NEVER KEEP BREWED ICED BEVERAGES OVERNIGHT**

## WARRANTY

Bunn-O-Matic Corp. ("Bunn") warrants the equipment manufactured by it to be commercially free from defects in material and workmanship existing at the time of manufacture and appearing within one year from the date of installation. In addition:

1.) Bunn warrants electronic circuit and/or control boards to be commercially free from defects in material and workmanship for two years from the date of installation.

2.) Bunn warrants the compressor on refrigeration equipment to be commercially free from defects in material and workmanship for two years from the date of installation.

3.) Bunn warrants that the grinding burrs on coffee grinding equipment will grind coffee to meet original factory screen sieve analysis for three years from date of installation or for 30,000 pounds of coffee, whichever comes first.

This warranty does not apply to any equipment, component or part that was not manufactured by Bunn or that, in Bunn's judgement, has been affected by misuse, neglect, alteration, improper installation or operation, improper maintenance or repair, damage or casualty.

**THE FOREGOING WARRANTY IS EXCLUSIVE AND IS IN LIEU OF ANY OTHER WARRANTY, WRITTEN OR ORAL, EXPRESS OR IMPLIED, INCLUDING, BUT NOT LIMITED TO, ANY IMPLIED WARRANTY OF EITHER MERCHANTABILITY OR FITNESS FOR A PARTICULAR PURPOSE.** The agents, dealers or employees of Bunn are not authorized to make modifications to this warranty or to make additional warranties that are binding on Bunn. Accordingly, statements by such individuals, whether oral or written, do not constitute warranties and should not be relied upon.

The Buyer shall give Bunn prompt notice of any claim to be made under this warranty by telephone at (217) 529-6601 or by writing to Post Office Box 3227, Springfield, Illinois, 62708-3227. If requested by Bunn, the Buyer shall ship the defective equipment prepaid to an authorized Bunn service location. If Bunn determines, in its sole discretion, that the equipment does not conform to the warranty, Bunn shall repair the equipment with no charge for parts during the warranty period and no charge for labor by a Bunn Authorized Service Representative during the warranty period. If Bunn determines that repair is not feasible, Bunn shall, at its sole option, replace the equipment or refund the purchase price for the equipment.

**THE BUYER'S REMEDY AGAINST BUNN FOR THE BREACH OF ANY OBLIGATION ARISING OUT OF THE SALE OF THIS EQUIPMENT, WHETHER DERIVED FROM WARRANTY OR OTHERWISE, SHALL BE LIMITED, AS SPECIFIED HEREIN, TO REPAIR OR, AT BUNN'S SOLE OPTION, REPLACEMENT OR REFUND.**

In no event shall Bunn be liable for any other damage or loss, including, but not limited to, lost profits, lost sales, loss of use of equipment, claims of Buyer's customers, cost of capital, cost of down time, cost of substitute equipment, facilities or services, or any other special, incidental or consequential damages.