

SBCN

Abrasive Blast Cabinet Assembly & Operating Instructions



READ ALL INSTRUCTIONS AND WARNINGS BEFORE USING THIS PRODUCT.

This manual provides important information on proper operation & maintenance. Every effort has been made to ensure the accuracy of this manual. These instructions are not meant to cover every possible condition and situation that may occur. **We reserve the right to change this product at any time without prior notice.**

IF THERE IS ANY QUESTION ABOUT A CONDITION BEING SAFE OR UNSAFE, DO NOT OPERATE THIS PRODUCT!

HAVE QUESTIONS OR PROBLEMS? DO NOT RETURN THIS PRODUCT TO THE RETAILER - CONTACT CUSTOMER SERVICE.

If you experience a problem or need parts for this product, visit our website <http://www.buffalotools.com> or call our customer help line at **1-888-287-6981**, Monday-Friday, 8 AM - 4 PM Central Time. A copy of the sales receipt is required.

FOR CONSUMER USE ONLY – NOT FOR PROFESSIONAL USE.

KEEP THIS MANUAL, SALES RECEIPT & APPLICABLE WARRANTY FOR FUTURE REFERENCE.

TABLE OF CONTENTS

RECOGNIZE SAFETY SYMBOLS, WORDS AND LABELS	2
SERVICE.....	5
SPECIFIC SAFETY RULES AND/OR SYMBOLS.....	5
ASSEMBLY	5
OPERATION	6
MAINTENANCE	7
PARTS DIAGRAM.....	8
PARTS LIST.....	8

RECOGNIZE SAFETY SYMBOLS, WORDS AND LABELS

What You Need to Know About Safety Instructions

Warning and Important Safety Instructions appearing in this manual are not meant to cover all possible conditions and situations that may occur. Common sense, caution and care must be exercised when assembling or using this product.

Always contact your dealer, distributor, service agent or manufacturer about problems or conditions you do not understand.



This is a safety alert symbol. It is used to alert you to potential personal injury hazards. Obey all safety messages that follow this symbol to avoid possible injury or death.



This is a safety alert symbol. It is used to alert you to potential personal injury hazards. Obey all safety messages that follow this symbol to avoid possible injury or death.

GENERAL PRODUCT SPECIFICATIONS

FEATURES:

- Abrasive Blast Cabinet Vertical
- 4 Assorted Ceramic Nozzle
- Rubber Gloves
- Blasting Gun With Trigger
- Dust Collector Port
- Hopper & Screen

SPECIFICATIONS

- | | |
|--------------------|--------------------|
| • Tank Volume | 32 Lb Max Capacity |
| • Working Pressure | 40-80 PSI |
| • Air Consumption | 5 CFM |



KEEP THIS MANUAL, SALES RECEIPT & APPLICABLE WARRANTY FOR FUTURE REFERENCE.

READ ALL INSTRUCTIONS AND WARNINGS BEFORE USING THIS PRODUCT.

When unpacking, check to make sure all parts listed are included. If any parts are missing or broken, please call Customer Service at 1-888-287-6981.

FOR CONSUMER USE ONLY – NOT FOR PROFESSIONAL USE

IMPORTANT SAFETY RULES

COMMON SENSE AND CAUTION ARE FACTORS WHICH CANNOT BE BUILT INTO ANY PRODUCT. THESE FACTORS MUST BE SUPPLIED BY THE OPERATOR.

WARNING

Keep your work area clean and well lit. Cluttered work benches and dark work areas may cause accidents or injury.

Do not operate the abrasive blaster in explosive areas, such as in the presence of flammable liquids, gases or dust. Tools create sparks which may ignite the dust or fumes.

Keep bystanders, children and visitors away while operating the abrasive blaster. Distractions can cause you to lose control.

CAUTION

Do not force tool. Use the correct tool for your application. The correct tool will do the job better and safer at the rate for which it is designed.

Store idle tools out of reach of children and other untrained persons. Tools are dangerous in the hands of untrained users.

DANGER

Always check to make sure that the power switch is turned off before connecting blaster to power source. Tool may cause damage to property or person if plugged in while power switch is on.

WARNING

Keep children, and other distractions at a distance while operating the Blast Cabinet.

WARNING

Use common sense while operating this abrasive blast cabinet.

Do not use this tool if you are:

- Feeling tired or are under the influence of alcohol or drugs.
- Wearing loose clothing or jewelry. Keep long hair pulled back and away from moving parts.
- Overreaching or have improper footing. Handling the tool in this way could cause serious injury.
- When using this blast cabinet, always:
 - Wear the proper safety equipment, such as safety goggles, dust masks, non-skid shoes, etc.
 - Check that the power switch is in the "OFF" position before plugging the unit into an electrical outlet.

CAUTION

Use the correct tool for the job. Using the correct tool is safer and faster.

Check to be sure all moving parts are free from binding and are properly aligned.

Use only accessories that are recommended by the manufacturer for your tool model.

WARNING

Safety glasses and ear protection must be worn during operation.

If Gloves are punctured or if you feel air blowing in the Glove, replace them immediately. DO NOT use a damaged or punctured glove.

Abrasive media will not be effective after much use. Replace abrasive media periodically.

SERVICE

Tool service must be performed only by qualified repair personnel. Service or maintenance by unqualified personnel could result in a risk of injury.

When servicing a tool, use only identical replacement parts and follow instructions in the manual. Use of unauthorized parts or failure to follow Maintenance Instructions may create a risk of shock or injury.

SAVE THESE INSTRUCTIONS FOR FUTURE REFERENCE.

This manual contains important information regarding safety, operation, maintenance and storage of this product. Before use, read carefully and understand all warnings, cautions, instructions and labels. Failure to do so could result in serious personal injury, property damage or even death.

IMPORTANT SAFETY INSTRUCTIONS

WARNING





Before using this tool, you need to become familiar with its operation. If you are unsure about the operation of the tool, or have any questions about its proper use, call the Customer Service Department at 1-888-287-6981. Follow these instructions for safe handling of the tool:

- **Close and latch the door before operating the Blast Cabinet.**
- **Check for damaged parts before use.** Do not operate the Blast Cabinet if there are damaged parts.
- **Maintain proper footing.** Make sure you have secure footing and balance.
- **Clean spills and sand abrasive in the work area.**

SPECIFIC SAFETY RULES AND/OR SYMBOLS

SYMBOLS

The following symbols may be used on your tool. Be familiar with and learn the symbols to operate the tool safely.

Symbol	Name	Description
V	Volts	Voltage (Potential)
A	Amperes	Current
Hz	Hertz	Frequency (Cycles per Second)
W	Watt	Power
Kg	Kilograms	Weight
	Alternating Current	Type of Current
	Direct Current	Type of Current
	Alternating or Direct Current	Type of Current
	Earthing Terminal	Grounding Terminal
	Class II Construction	Denotes Double Insulation
min	Minutes	Time
s	Seconds	Time
ϕ	Diameter	Size of Drill Bits, Grinding Wheels, etc.
n_0	No Load Speed	No-load Rotational Speed
.../min	Revolutions per Minute	Revolutions, Surface Speed, Strokes, etc. per Minute
1,2,3...	Ring Selector Settings	Speed, Torque or Position Settings

ASSEMBLY

WARNING

Be certain the Blast Cabinet is not connected to a power source before assembly. Plug the Blast Cabinet into a power source only when assembly is complete.

Installing the Legs

1. Unpack the unit and place cabinet, with the viewing window face down, on a table.
2. Loosen the clamp which holds the glove opposite the door and remove glove from mounting ring.

3. Align the four holes on any of the legs with the corresponding holes on cabinet.
4. Attach the leg to the cabinet by inserting a short screw with washer through the leg, then through cabinet, and nut. Firmly tighten nut. Repeat for all holes.
5. Repeat steps 3 and 4 for remaining legs.
6. Place screen frame into cabinet with flat edge of frame facing the bottom of cabinet.

Installing Cabinet Funnel and Shelf

1. Install the Abrasive Suction Pipe into the Cabinet Funnel, securing in place with 2 short screws, 2 washers, and 2 nuts.
2. Place the open end of the Cabinet Funnel on top of the Screen Frame with Abrasive Suction Pipe towards front of unit.
3. Align the holes in the lip of the Cabinet Funnel with holes in the Screen Frame and Cabinet.
4. Attach the Cabinet Funnel to the Screen Frame and Cabinet by inserting a long screw with washer through each of the holes in the Cabinet, Screen Frame and Cabinet Funnel. Place a nut onto end of each screw, and hand tighten nuts.
5. Attach the shelf to the legs by inserting a short screw with washer through each of the holes in the legs, then through the shelf and nut. Securely tighten nuts.

Final Assembly

1. Carefully stand unit upright.
2. Level unit on all four legs and then securely tighten all nuts.
3. Re-install Rubber Glove onto Mounting Ring and tighten in place with Clamp.
4. Open side door of Cabinet and place steel screen into place on Screen Frame. Steel Screw will seat itself into recessed area of Screen Frame when it is properly aligned.
5. Secure plastic Abrasive Intake Hose to Abrasive Suction Pipe with the clamp provided. Tighten clamp securely.
6. Wrap the threads of the Air Hose Adapter with tape and place a Washer onto Air Hose Adapter. Insert the threaded end of the Air Hose Adapter through the Hose Inlet Fitting located on the front of the Cabinet. Place another Washer onto threaded end of Air Hose Adapter and then securely tighten the Air Adapter Nut onto threaded end of Air Hose Adapter. Connect the air hose from your air compressor the Air Adapter Nut.

You will need a Union fitting (sold separately) before you can connect your Blast Cabinet to an air compressor. attach the Union fitting to the Air Inlet and tighten the fitting. Attach a Quick Connect Set-Up (sold separately) to the Union fitting if desired. This is a useful accessory as it allows quick-coupling action when using a variety of tools with the same air compressor.

OPERATION

⚠ CAUTION

Always wear your hood, dust mask and heavy duty canvas gloves when operating the abrasive blaster. Close and latch the door prior to operating the cabinet.

⚠ WARNING

Before operating your abrasive blaster, inspect each connection, double checking to make sure that all are tight and properly sealed.

⚠ WARNING

THIS MACHINE IS NOT INTENDED FOR USE WITH SILICA BASED ABRASIVES. SILICA BASED ABRASIVES HAVE BEEN LINKED TO SEVERE RESPIRATORY DISEASE. ALWAYS USE SILICA SUBSTITUTES WHEN ABRASIVE BLASTING!

When using your abrasive blast cabinet, a 5 HP compressor is recommended with a fine grade of abrasive.

Open the Blast Cabinet Window and fill the cabinet with fine abrasive material. Use about 10 pounds.

The Sand will feed from the air tube. The air hose is attached to the base of the gun. Connect the air compressor. Set the compressor pressure regulator to 80 PSI. Do not exceed 80 PSI.

Open the cabinet window and place the work piece in the center. Close the window securely. Insert your hands into the gloves. Be certain your fingers are properly positioned and you can move your hands easily and grip the work piece comfortably.

Point the nozzle and operate the gun to be certain that the blaster is working correctly. Make certain there is no leaks. Hold the work piece, and position your fingers so that the glove is not in the way of the work piece. Reposition the work piece as needed in order to access the complete surface area.

Use a circular motion or side-to-side motion, and the nozzle should be 2 inches away from the work piece.

Once the work piece is completed, remove your hands from the gloves & turn the blaster and compressor off.

Dirt and water in the air supply are major causes of pneumatic tool wear. Use a filter/oiler for better performance & longer life of the tool. The filler must have adequate flow capacity of r the specific application.

MAINTENANCE

⚠ WARNING

Keep your abrasive blaster clean, and protect it from damage.

Check for damaged parts before and after use. Replace any parts which appear worn. Call customer service for replacement parts if needed. After 10-12 hours of blasting time, the nozzle should be checked. If it shows uneven wear it should be turned 1/4 turn every 10 hours of use.

TROUBLESHOOTING

If abrasive media doesn't fire from the Abrasive Gun, make sure that you are using the right size Ceramic Nozzle for your abrasive.

If not enough abrasive media is coming from the Abrasive Gun, check the level of abrasive in the Cabinet Funnel. If the level is too low, add additional abrasive.

If the light does not work, check to make certain that the electrical plug is plugged into an outlet and that the Switch is ON.

If the dust collector has insufficient air movement/vacuum, check to make sure that the Intake Vent Cover is off when using a dust collector.

PARTS DIAGRAM

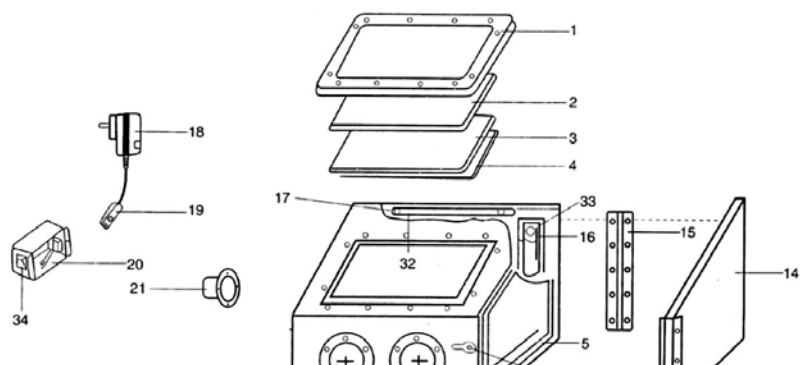

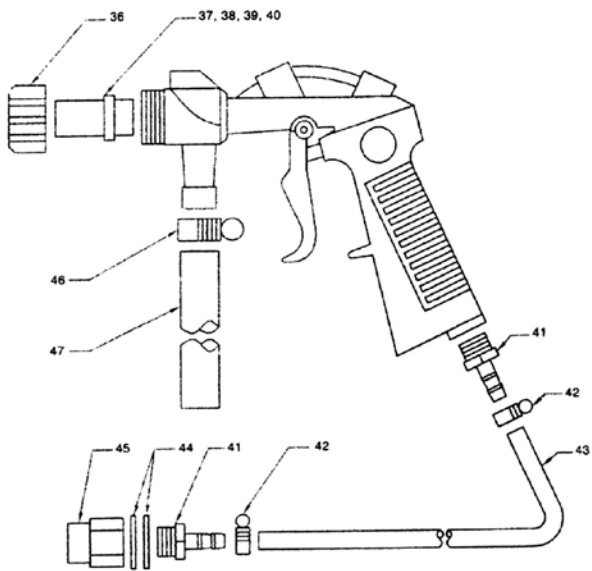

PARTS LIST

Part #	Description	Part #	Description
SBCN1	Frame	SBCN26	Suction Hose
SBCN2	Glass	SBCN27	Mounting Ring, glove
SBCN3	Glass Board	SBCN28	Clamp
SBCN4	Protection Film	SBCN29	Gloves
SBCN5	Cabinet	SBCN30	Feet
SBCN6	Steel Screen	SBCN31	Screws, nuts, washers
SBCN7	Screen Frame	SBCN32	Light, low voltage
SBCN8	Cabinet Funnel	SBCN33	Intake vent
SBCN9	Abrasive Suction Pipe	SBCN34	Switch low voltage
SBCN10	Abrasive Removal Cover	SBCN36	Nozzle adapter nut
SBCN11	Cover Lock	SBCN37	Abrasive nozzle 4mm
SBCN12	Shelf	SBCN38	Abrasive nozzle 5mm
SBCN13	Legs	SBCN39	Abrasive nozzle 6mm
SBCN14	Plastic Door	SBCN40	Abrasive nozzle 7mm
SBCN15	Hinge	SBCN41	Air hose adapter
SBCN16	Intake Vent Cover	SBCN42	Worm drive clip diameter 10
SBCN17	Light Clamp	SBCN43	Air hose
SBCN18	Transformer low voltage	SBCN44	Flat washer
SBCN19	Plug, low voltage	SBCN45	Air adapter nut
SBCN20	Switch box, low voltage	SBCN46	Clamp
SBCN21	Suction flange 2 1/2" x 2 1/4"	SBCN47	Abrasive intake hose
SBCN22	Hose inlet fitting		
SBCN23	Latch		
SBCN24	Metal liner		
SBCN25	Abrasive gun		