



breatheaudio™
elevate

EXPERIENCE THE RHYTHM OF YOUR LIFE

Six Source, Six Zone Audio Distribution System



ENGLISH

Danger

Exposure to extremely high noise levels may cause a permanent hearing loss. Individuals vary considerably to noise induced hearing loss but nearly everyone will lose some hearing if exposed to sufficiently intense noise for a sufficient time. The U.S. Government's Occupational Safety and Health Administration (OSHA) has specified the following permissible noise level exposures:

DURATION PER DAY (HOURS)	8	6	4	3	2	1
SOUND LEVEL (dB)	90	93	95	97	100	103

According to OSHA, any exposure in the above permissible limits could result in some hearing loss. Ear plugs or protectors in the ear canal or over the ears must be worn when operating this amplification system in order to prevent a permanent hearing loss. If exposure in excess of the limits as put forth above, to insure against potentially harmful exposure to high sound pressure levels, it is recommended that all persons exposed to equipment capable of inducing high sound pressure levels, such as this amplification system, be protected by hearing protectors while this unit is in operation.

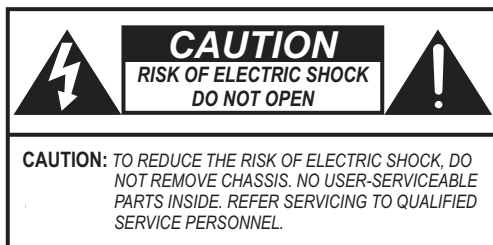

AVIS: RISQUE DE CHOC ELECTRIQUE-NE PAS OUVRIR.



THIS SYMBOL IS INTENDED TO ALERT THE USER TO THE PRESENCE OF NON-INSULATED "DANGEROUS VOLTAGE" WITHIN THE PRODUCT'S ENCLOSURE THAT MAY BE OF SUFFICIENT MAGNITUDE TO CONSTITUTE A RISK OF ELECTRIC SHOCK TO PERSONS.



THIS SYMBOL IS INTENDED TO ALERT THE USER TO THE PRESENCE OF IMPORTANT OPERATING AND MAINTENANCE (SERVICING) INSTRUCTIONS IN THE LITERATURE ACCOMPANYING THE UNIT.



APPARATUS SHALL NOT BE EXPOSED TO DRIPPING OR SPLASHING AND THAT NO OBJECTS FILLED WITH LIQUIDS, SUCH AS VASES, SHALL BE PLACED ON THE APPARATUS.

IMPORTANT SAFETY INSTRUCTIONS

1. Read all safety and operating instructions before using this product.
2. All safety and operating instructions should be kept for future reference.
3. Read and understand all warnings listed on the operating instructions.
4. Follow all operating instructions to operate this product.
5. This product should not be used near water, i.e. bathtub, sink, swimming pool, wet basement, etc.
6. Only use dry cloth to clean this product.
7. Do not block any ventilation openings, It should not be placed flat against a wall or placed in a built-in enclosure that will impede the flow of cooling air.
8. Do not install this product near any heat sources ; such as, radiators, heat registers, stove or other apparatus (including heat producing amplifiers) that produce heat.
9. Do not defeat the safety purpose of the polarized or grounding-type plug. A polarized plug has two blades with one wider than the other. A grounding-type plug has two blades and a third grounding prong. The wide blade or the third prong are provided for your safety. If the provided plug does not fit into your outlet, consult an electrician for replacement of the obsolete outlet.
10. Protect the power cord being walked on or pinched, particularly at plugs, convenience receptacles and the point where they exit from the apparatus. Do not break the ground pin of the power supply cord.
11. Only use attachments specified by the manufacturer.
12. Use only with the cart, stand, tripod, bracket, or table specified by the manufacturer or sold with the apparatus. When a cart is used, use caution when moving cart/apparatus combination to avoid injury from tip-over.
13. Unplug this apparatus during lightning storms or when unused for long periods of time.
14. Care should be taken so that objects do not fall and liquids are not spilled into the unit through the ventilation ports or any other openings.
15. Refer all servicing to qualified service personnel. Servicing is required when the apparatus has been damaged in any way; such as, power-supply cord or plug is damaged, liquid has been spilled or objects have fallen into the apparatus, the apparatus has been exposed to rain or moisture, does not operate normally or has been dropped.
16. **WARNING:** To reduce the risk of fire or electric shock, do not expose this apparatus to rain or moisture.

FRENCH

Danger

L'exposition a des niveaux eleves de bruit peut provoquer une perte permanente de l'audition, Chaque organisme humain reagit differemment quant a la perte de l'audition, mais quasiment tout le monde subit une diminution de l'acuite auditive lors d'une exposition suffisamment longue au bruit intense. Les autorites competentes en reglementation de bruit ont defini les expositions tolerees aux niveaux de bruits:

DURE EN HEURES PAR JOUR	8	6	4	3	2	1
INIVEAU SONORE CONTINU EN dB	90	93	95	97	100	103

Selon les autorites, toute exposition dans les limites citees ci-dessus, peuvent provoquer certaines pertes d'audition. Des bouchons ou protections dans l'appareil auditif ou sur l'oreille doivent etre portes lors de l'utilisation de ce systeme d'amplification afin de prevenir le risque de perte permanente de l'audition, Dans le cas d'expositions superieures aux limites precitees il est recommande, afin de se premunir contre les expositions aux pressions acoustiques lvees potentiellement dangeure u ses, aux personnes exposees aux equipements capables de delivrer de telles puissances, tels ce systeme d'amplification en fonctionnement, de proteger l'appareil auditif.



CE SYMBOLE A POUR BUT D'AVERTIR L'UTILISATEUR DE LA PRESENCE DE VOLTAGE DANGEREUX NON-ISOLE A L'INTERIEUR DE CE PRODUIT QUI PEUT ETRE DE PUISSANCE SUFFISAMMENT IMPORTANTE POUR PROVOQUER UN CHOC ELECTRIQUE AUX PERSONNES.



CE SYMBOLE A POUR BUT D'AVERTIR L'UTILISATEUR DE LA PRESENCE D'INSTRUCTIONS D'UTILISATION ET DE MAINTENANCE DANS LES DOCUMENTS FOURNIS AVEC CE PRODUIT.



AFIN DE REDUIRE LES RISQUÉ D'INCENDIE ET DE DECHARGE ELECTRIQUE, NE PAS EXPOSER CET APPAREIL A LA PLUIE OU A L'HUMIDITE.

IMPORTANTES INSTRUCTIONS DE SECURITE

1. Lire avec attention toutes les recommandations et précautions d'emploi avant d'utiliser ce produit.
2. Toutes les recommandations et précautions d'emploi doivent être conservées afin de pouvoir s'y reporter si nécessaire.
3. Lire et comprendre tous les avertissements énumérés dans les précautions d'emploi.
4. Suivre toutes les précautions d'emploi pour utiliser ce produit.
5. Ce produit ne doit pas être utilisé près d'eau, comme par exemple baignoires, éviers, piscine, sous-sol humides ... Etc.
6. Utiliser exclusivement un chiffon sec pour nettoyer ce produit.
7. Ne bloquer aucune ouverture de ventilation. Ne pas placer le produit tout contre un mur ou dans une enceinte fermée, cela générerait le flux d'air nécessaire au refroidissement.
8. Ne pas placer le produit près de toute source de chaleur telle que radiateurs, arrivées d'air chaud, fourneaux ou autres appareils générant de la chaleur (incluant les amplificateurs producteurs de chaleur) .
9. Ne pas négliger la sécurité que procure un branchement polarisé ou avec raccordement à la terre, Un branchement polarisé comprend deux fiches dont l'une est plus large que l'autre. Un branchement à la terre comprend deux fiches plus une troisième reliée à la terre. Si la fiche secteur fournie ne s'insert pas dans votre prise de courant. consulter un 'électricien afin de remplacer votre prise obsolète.
10. Protéger le cordon d'alimentation de tout écrasement ou pincement, particulièrement au niveau des fiches, des réceptacles utilisés et à l'endroit de sortie de l'appareil. Ne pas casser la fiche de terre du cordon d'alimentation.
11. Utiliser uniquement les accessoires spécifiés par le constructeur.
12. Utiliser uniquement avec le chariot de transport, le support, le trépied, la console ou la table spécifiés par le constructeur ou vendus avec l'appareil. Lors de l'utilisation d'un chariot, bouger avec précaution l'ensemble chariotlappareil afin d'éviter les dommages d'un renversement.
13. Débrancher cet appareil lors d'orages ou s'il n'est pas utilisé pendant une longue période.
14. Des précautions doivent être prises afin qu'aucun objet ne tombe et qu'aucun liquide ne se répande à l'intérieur de l'appareil par les orifics de ventilation ou n'importe quelle autre ouverture.
15. Pour toutes interventions techniques s'adresser à un technicien qualifié.L'intervention technique est nécessaire lorsque l'appareil a été endommagé de n'importe quelle façon, comme par exemple si le cordon secteur ou sa fiche sont détériorés,si du liquide a coulé ou si des objets sont tombés à l'intérieur de l'appareil1,si l'appareil a été exposé à la pluie ou à l'humidité, s'il ne fonctionne pas normalement ou s'il est tombé.
16. ATTENTION:Pour réduire le risque d'incendie ou de choc électrique ne pas exposer l'appareil à la pluie ou à l'humidité.

Introduction

The new Elevate 6.6 whole-home audio system is the perfect 6 source, 6 zone audio system for any home. Jazz up the kitchen, do the salsa on the patio, and let the kids listen to... what ever kids listen to these days... in the living room, and so on. You can choose music from six audio sources in up to 6 zones throughout the home, or easily expand the system to 12 zones. Providing music for the entire family is easy with the Elevate 6.6.

BA-6640MS Package Contents

Qty	Description
1	BA-6640M 6 source, 6 zone amplifier
6	BA-6640KP Keypads with white, ivory, almond and black inserts and trim plates
1	BA-6640AP Allport Connection Hub
1	BA-6640APC Allport Cable
6	BA-VEC Visible LED IR emitters
1	BA-NC1 Network cable
1 pr.	BA-REM double space rack ear mounts
1	BA-PC2-NA Power cable, 2 wire, (North America only)

BA-6640XS Expander Package Contents

Qty	Description
1	BA-6640X 6 zone expander amplifier
6	BA-6640KP Keypads with white, ivory, almond and black inserts and trim plates
1	BA-6640AP Allport Connection Hub
1	BA-6640APC Allport Cable
1	BA-DLC 15 Pin Digital Link Cable
1	BA-SLC1 26 Pin Source Link Cable
1	BA-NC3 3 foot black Network Cable
1 pr.	BA-REM double space rack ear mounts
1	BA-PC2-NA Power cable, 2 wire, (North America only)

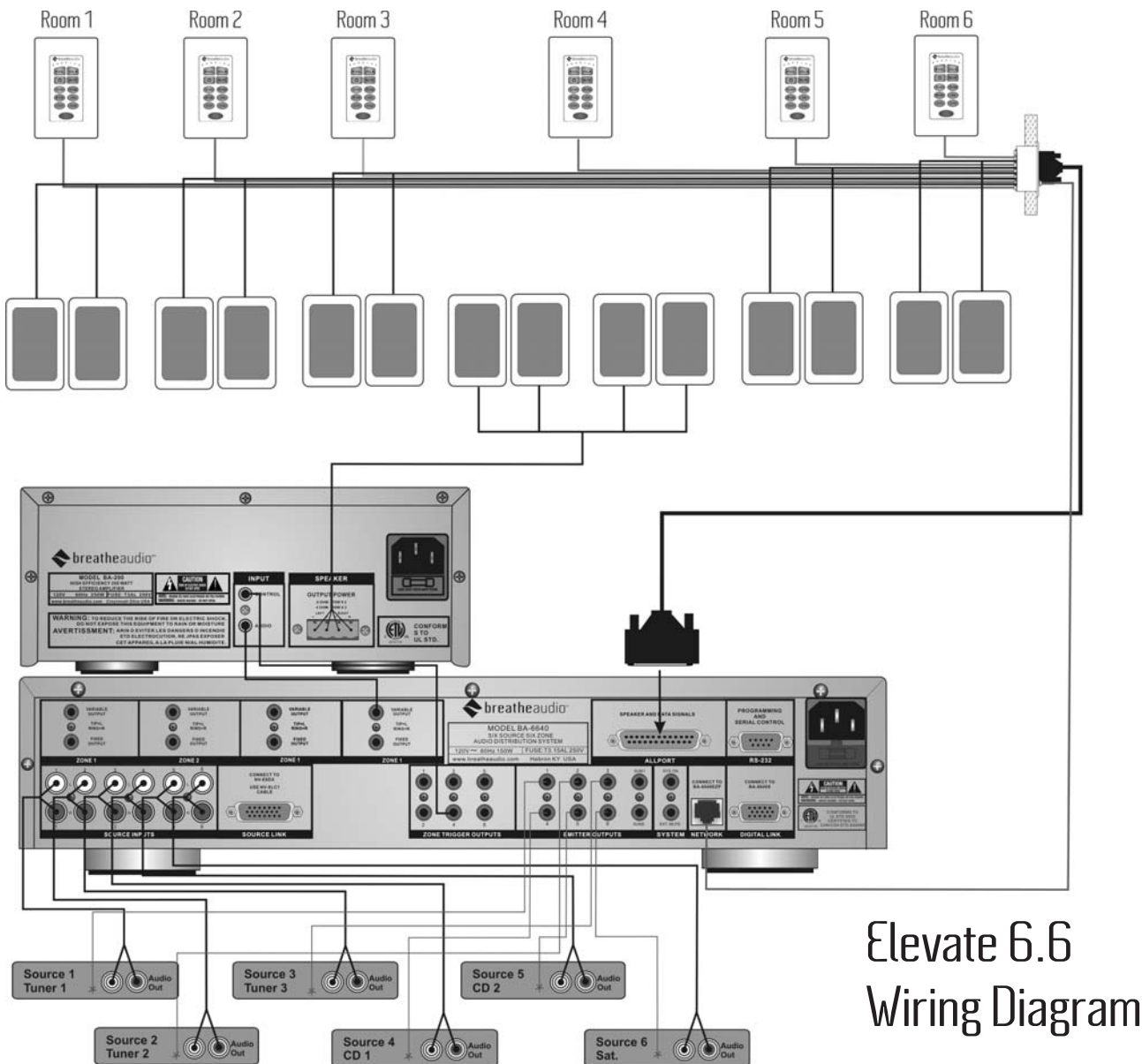

Elevate 6.6
Wiring Diagram

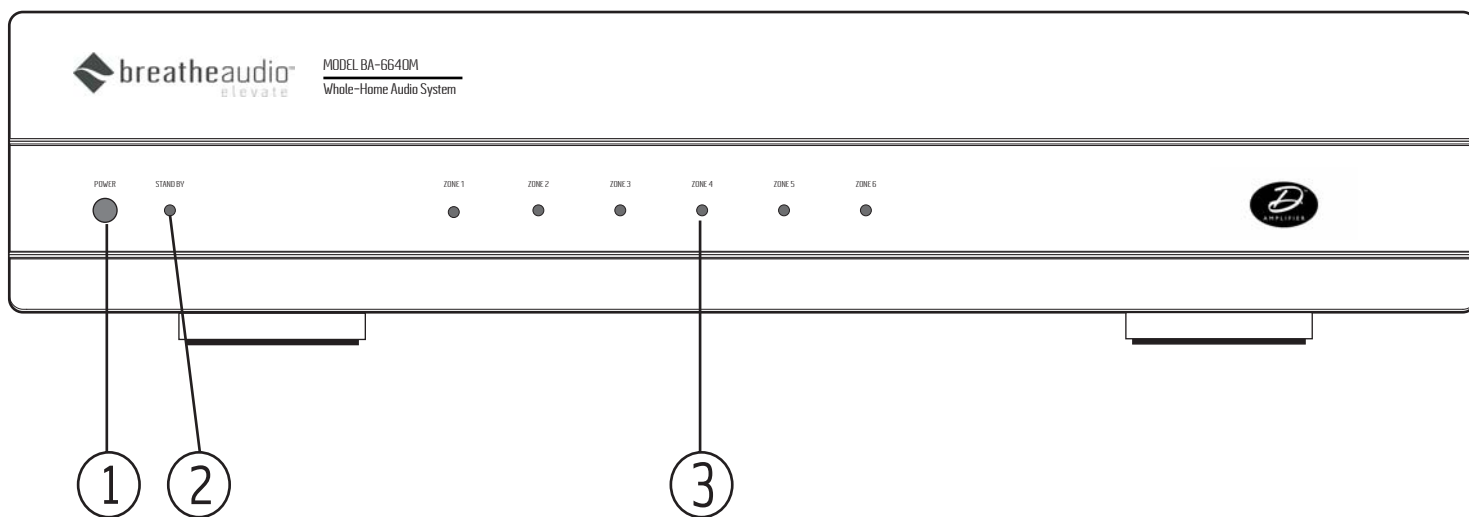

Elevate 6.6 Front Panel

1. **POWER Button:** The amplifier is designed to be turned on and remain on. The power button supplies power to the system. Each zone can then be turned on or off independently. The amplifier should be turned on before any external connections are made. This activates internal protective circuitry.
2. **STAND BY LED:** When lit, this blue LED (light-emitting diode) indicates that the amplifier is plugged into an AC power outlet source.
3. **Zone Status LED's:** These LED's indicate the power status of each zone. When a zone LED is lit, it indicates that the keypad in that zone has been activated.

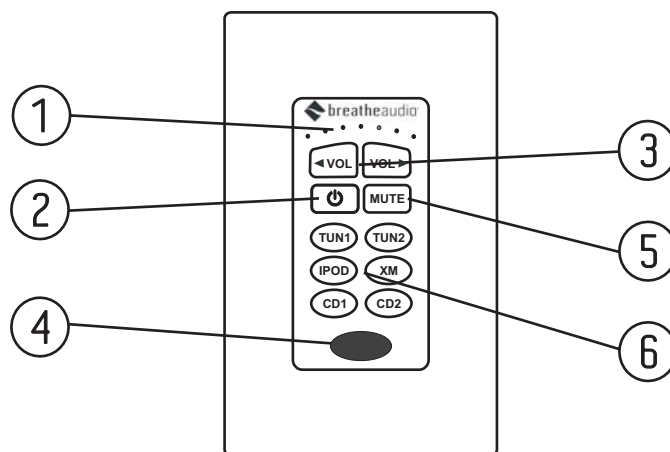

Keypad Features

1. **Volume Level** The level of the zone volume is indicated by these LEDs (light-emitting diodes).
2. **Power** The power button turns that keypad's zone on and off independently of the other zones. Pressing and holding the power button turns all zones off simultaneously.
3. **Volume** Independent audio volume level for each zone is controlled with these buttons.
4. **IR Receiver** Each keypad has an IR (infrared) receiver for wireless control of the audio source equipment.
5. **Mute** The mute button temporarily silences any audio playing in that keypad's zone.
6. **Source Selection Buttons** The source buttons independently select any of the six sources connected to the Elevate 6.6 amplifier. The selected source button will remain lit while in use.

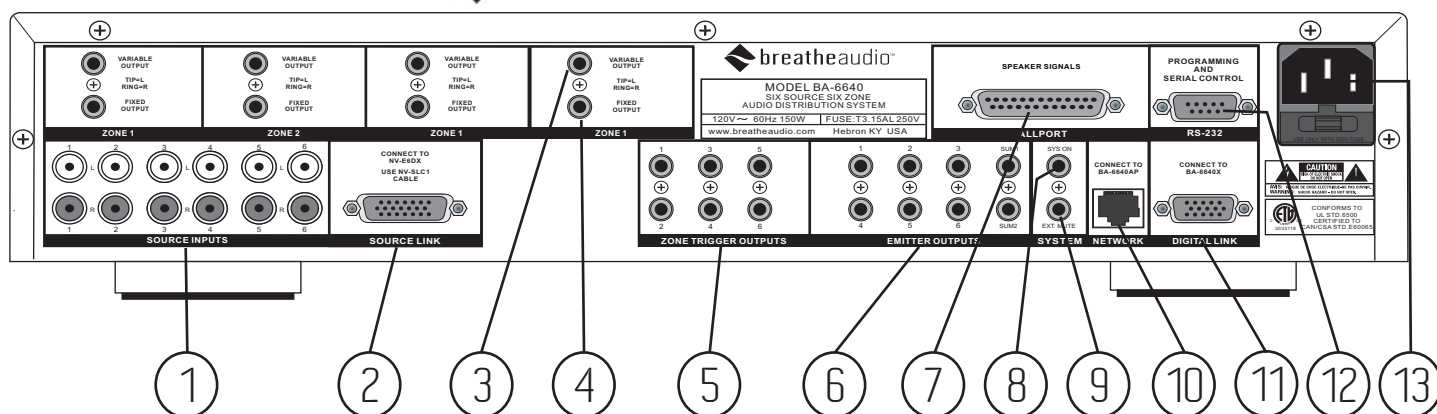

Elevate 6.6 Back Panel

1. **Audio Source Inputs:** The Elevate 6.6 amplifier accepts up to six audio sources. A source consists of any audio component capable of supplying a line level signal.
2. **Source Link:** This multi-pin connection is used to transfer the audio information from the Elevate 6.6 main amplifier to the expander amplifier. This output is only used to expand the system to twelve zones. The source link connection cable is provided with the Elevate 6.6 Expander package.
3. **Variable Lineout:** The variable lineout is intended for zones where additional amplification is needed and the Elevate 6.6 keypad is used to control the volume of all the speakers in that zone.
4. **Fixed Lineout:** The fixed lineout is intended for zones where additional amplification and separate volume control are needed.
5. **Zone Triggers:** These outputs provide a 12-volt output when the corresponding zone is turned on. This is used to trigger external equipment specific to a given zone.
6. **Emitter Outputs:** These outputs transfer IR (infrared) signals, repeated from a zone keypad, from the Elevate 6.6 amplifier to the audio source equipment. There are six source specific outputs and two "sum" outputs that sends IR signals regardless of the selected source.
7. **Speaker Outputs:** Individual stereo speaker outputs for each zone provide 20 watts output per channel. The speaker connection at the back of the amplifier is a unique single termination using the included Allport Cable.
8. **System On:** This output provides a constant 12-volt output when any zone is turned on. This is used to trigger external devices.
9. **External Mute:** This is designed to mute any audio playing through the system when the phone or doorbell rings.
10. **Network Input:** This RJ-45 connection is the input for all zone information coming from the Elevate 6.6 keypads. The connection is made using the Network Cable supplied with the package.
11. **Digital Link:** This multi-pin connection transfers all the digital information from the main amplifier to the expander amplifier. This output is used to expand the system from six to twelve zones. The Digital Link connection cable is provided with the Elevate 6.6 Expander package.
12. **RS232 Port:** The RS232 serial port allows two-way communication for control by a home automation system.
13. **AC Power:** A detachable power cable supplies power to the Elevate 6.6 System from any AC outlet.

Installing the Elevate 6.6 System in Your Home

I. Prewire

The Elevate 6.6 System uses CAT5 cable for keypad control and either two or four-conductor 16-gauge speaker wire. All the wire is "homerun" from each zone to the location of the Elevate 6.6 amplifier and Audio Source equipment.

Complete CAT5 Crimping Instructions

The Breatheaudio audio systems require CAT5, unshielded, twisted pair (UTP), for communication between the keypads/Display Pads and the main amplifier unit. Each end of the wire is terminated with an RJ45 connector.

The Elevate 6.6 System can accommodate 2,000 total feet of CAT5 cable. For the most reliable operation, it is best that no single run of CAT5 exceeds 250 feet.

The correct wiring scheme for the CAT5 cable is standard EIA/TIA 568A or the commercial standard, 568B. Properly terminating the CAT5 cable is crucial for the operation of the system. It is very important to use a good quality crimp tool, and test each end to end run with a CAT5 wire tester to insure that your system operates flawlessly, fig.1. The BA-AWT1 Allport tester is available and sold separately.

Step-by-Step Crimping Instructions:

- Strip a 2 to 3 inch portion of the insulation, exposing the 4 twisted pairs.
- Untwist the wires and fan them out individually. Arrange the wires into the correct color scheme as shown in Fig. 1.
- Flatten the wires in their correct order, and trim them evenly across the top. Most crimp tools have a wire trimmer built-in. It is best to trim the wires to about $\frac{1}{2}$ " in length.
- While holding the wires flat between your thumb and forefinger, insert the wires into the RJ45 connector, so each is in its own slot. Push the wire into the RJ45, so all 8 conductors touch the end of the connector. The insulation jacket should extend beyond the crimp point of the RJ45.
- Insert the RJ45 into the crimp tool receptacle and squeeze the tool firmly. Note that a ratchet type tool should tighten down until it no longer clicks.
- The RJ45 should be firmly crimped to the CAT5 insulation. It is necessary that the color scheme be repeated identically on each end of the wire.

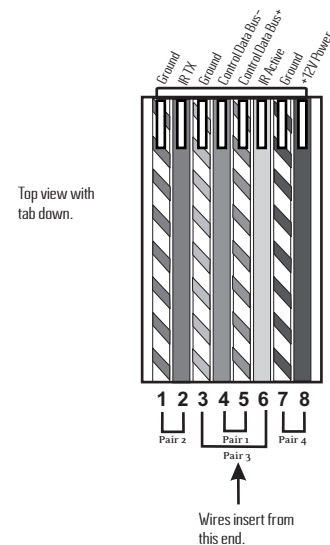

Fig. 1: EIA 568A wiring scheme for CAT5 Cable

- Pin #
1. Green Stripe
 2. Green
 3. Orange Stripe
 4. Blue
 5. Blue Stripe
 6. Orange
 7. Brown Stripe
 8. Brown

Note: Colors listed as "stripe" are a white wire with a colored stripe.

Step 1



Step 2



Step 3



Step 4



Step 5



Step 6

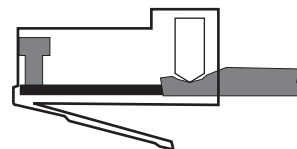

II. Installing the Elevate 6.6 Amplifier

System setup works best when the amplifier is placed in the same location as the audio source equipment. This is typically in an audio rack, entertainment center or a closet dedicated to housing the home audio/video equipment.

The amplifier should be plugged in and the power button on the front panel should be depressed before proceeding with the rest of the installation. This activates the internal protective circuitry of the Elevate 6.6 System.

II. Terminating Speaker Wire

The speaker wire for each zone is terminated at the back of the system's Allport. The six zone screw down terminals are located on each side and labeled for the appropriate zone. The common speaker termination scheme is Left - Left +, Right - Right +. Either two or four-conductor 16-gauge wire is recommended. Larger than 14-gauge wire will not fit into the termination.

To terminate the speaker wire, strip back the outer jacket and expose the inner conductors. Strip approximately 1/4" [4 mm] of the insulation from the inner conductors exposing the copper wire. Place the exposed wire in the appropriate termination and tighten the screw to hold the wire in place, fig. 2.

Be careful not to allow the exposed wire from each conductor to touch the adjacent conductor. This will short the speaker input. Each speaker output is designed for two 8-Ohm speakers. Overloading the amplifier could cause it to overheat and do damage to the output.

III. Installing the BA-6640AP Allport

The Allport is a multi-connection hub designed to accept all the CAT5 and speaker wires from the keypads in the system. Both the BA-6640MS main system and the BA-6640XS six zone expander system have an Allport included designed for up to six zones of speakers and keypads. When using both the BA-6640MS main system and the BA-6640 expander system for a full twelve zones, connect the two Allport with a short CAT5 jumper wire, see fig.8 page 9. The location of the Allport should be determined by the location of the Elevate 6.6 amplifier. It is best to place it in the wall behind the amplifier that would be easily accessible if necessary.

The Allport fits easily in any dual-gang size construction bracket with an open back. These are often referred to as "mud rings". Simply plug the terminated CAT5 wires into any of the available RJ-45 jacks on the back of the Allport, Fig. 3. The order in which the individual CAT5 wires are plugged is in not important, although it is strongly recommended that you label the CAT5 with the appropriate zone number for future reference.

Once you have plugged the CAT5 wires into the Allport, screw the Allport into its construction bracket using the supplied mounting screws.

Fig. 2

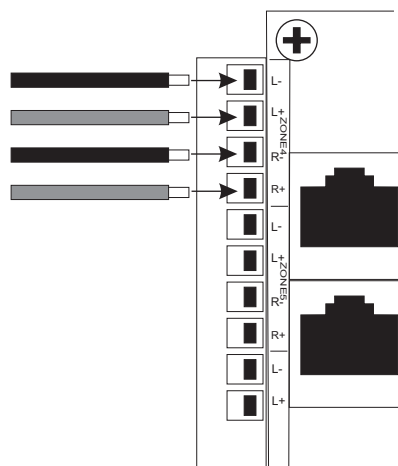
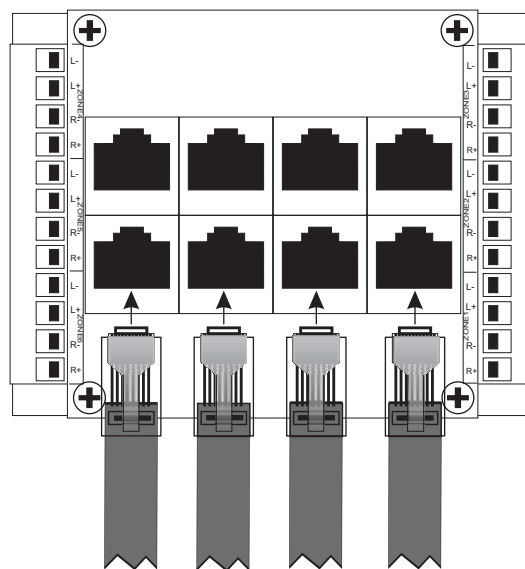

Fig. 3



IV. Connecting the Allport to the Elevate 6.6 amplifier

When the Allport is installed in the wall the only part visible should be the faceplate with a 25 pin connector for the Speaker Allport Cable and a single RJ45 jack. The supplied Allport Cable and the pre-terminated network cable can then be plugged into the appropriate jack on the Allport and into the Speaker Signal and Network connections on the back of the Elevate 6.6 amplifier, Fig. 4.

Fig. 4

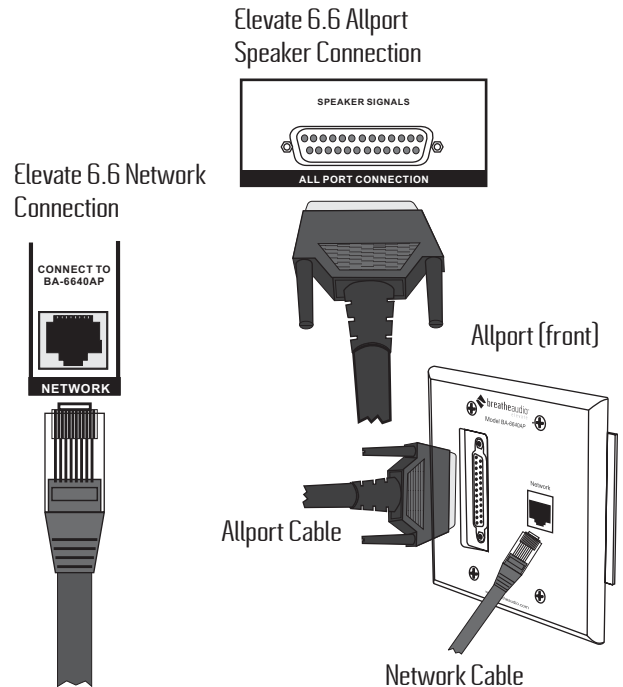

V. Attaching Audio Source Equipment to the Elevate 6.6 Amplifier

Each piece of audio source equipment is connected to the Elevate 6.6 amplifier with standard stereo RCA cables. Attach the RCA cable to the corresponding audio output on the source equipment and to the desired source input on the back of the Elevate 6.6 amplifier, Fig. 5.

Fig. 5

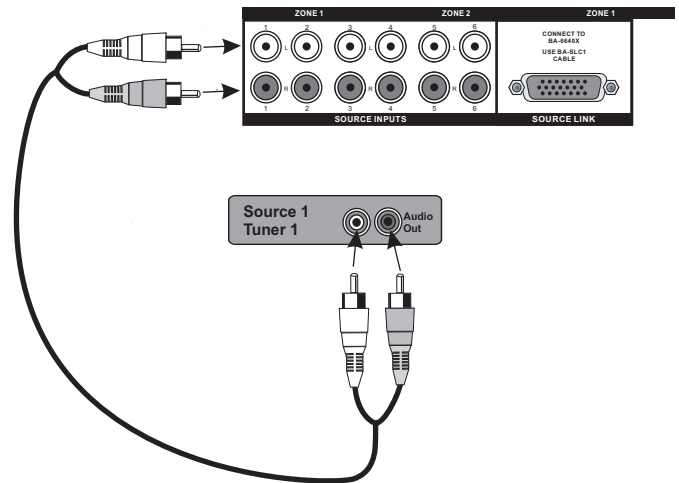

VI. Connecting the IR Emitters

IR commands for the source equipment are transferred from the Elevate 6.6 amplifier to the source equipment via mini IR mouse emitters. Six of these are supplied with your Elevate 6.6 System. The emitter is plugged into the corresponding source IR output on the Elevate 6.6 and then placed over the IR receiver window on the source component, fig. 6. The IR outputs are individually routed to sources 1–6 allowing IR commands from the chosen source to only control that source.

Fig. 6

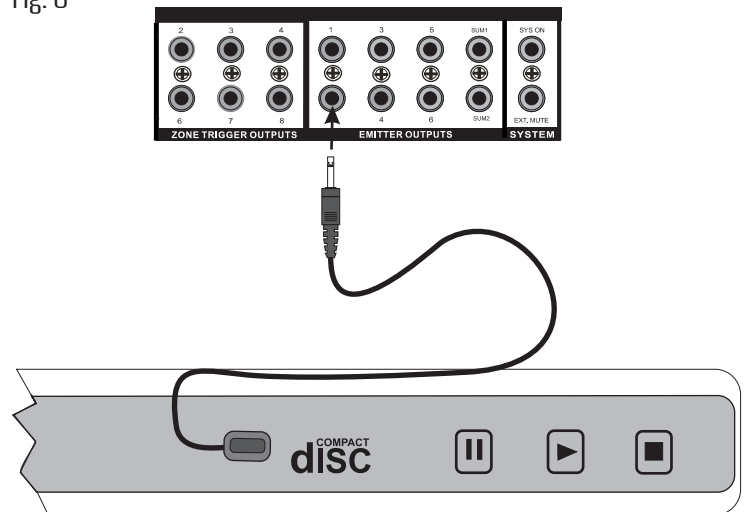

The two SUM outputs will flash any IR command that is sent from any of the zones. This can be used with an IR blaster designed to flash IR commands to a variety of components. This is done by plugging a single mono 1/8" patch cable into the SUM IR output and into the Direct IR input on the blaster.

VII. Expanding Elevate 6.6 to 12 Zones

Six additional listening zones can be added to the Elevate 6.6 System using the Elevate 6.6 Expander package. The expansion is easily done using the Source Link and Digital Link multi-pin outputs on the Elevate 6.6 main amplifier, Fig. 7. The Source Link and Digital Link cables are supplied with the expander package, and are plugged into the Source Link and Digital Link inputs on the Expander amplifier.

An additional Allport Hub is included with the Expander package to allow for the additional zone speaker and keypad connections. Terminate the speakers for zones 7–12 in the same fashion as zones 1–6, page 7, fig. 2, into the Expander Allport. The included multi-pin Allport Cable is used to connect the speakers from the Expander Allport to the Allport connection on the back of the Expander amplifier. The additional CAT5 cables for the zone 7–12 keypads must also be plugged into the Expander package Allport, see page 7 fig. 3. An additional BA-NC3 Network Cable is supplied to act as a jumper from the Expander Allport to the Main Allport, fig. 8. This combines all of the keypad CAT5 cables into one CAT5 connection at the Main Elevate 6.6 amplifier. No other connections are necessary with the exception of the AC power cord. Note that the “Network” RJ-45 connection on the Expander Allport is not used.

VIII. Installing the Elevate 6.6 Keypads

You are now ready to install the keypads and complete the Elevate 6.6 installation. This is easily done using a rotary switch located on the back of the keypad to set a specific zone address, Fig. 9.

The switch requires the use of a small flat screwdriver and is set by turning the arrow insert on the switch to the appropriate zone number. Zones 1–12 are set by using switch positions 1–C (note that zones 10, 11 and 12 are denoted by A, B and C respectively). Switch positions D, E, F and O are for additional keypads in zones 1–4.

It is important to note that the keypads will NOT function properly unless each has its own unique zone address.

Once each keypad’s zone address is set, the CAT5 can be plugged in and the keypad should then be installed in the wall.

The System will not recognize a zone setting if it is set while keypad is plugged into the CAT5.

Fig. 7

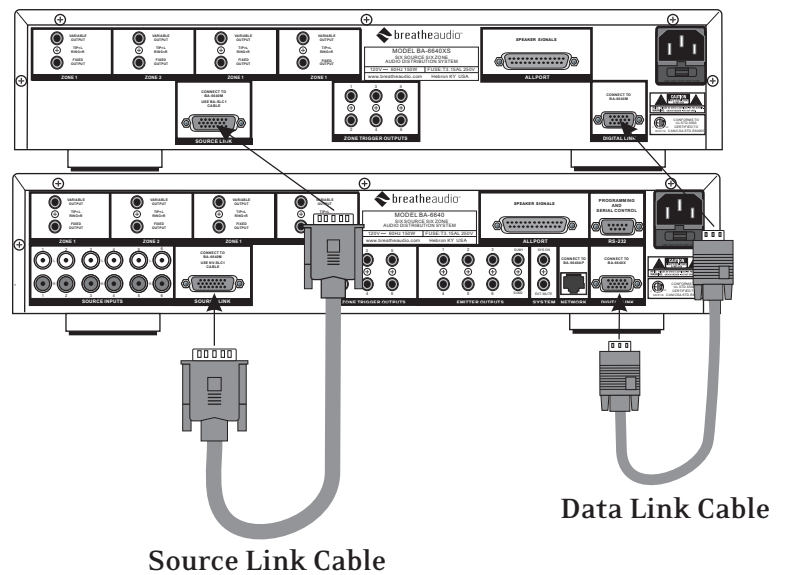
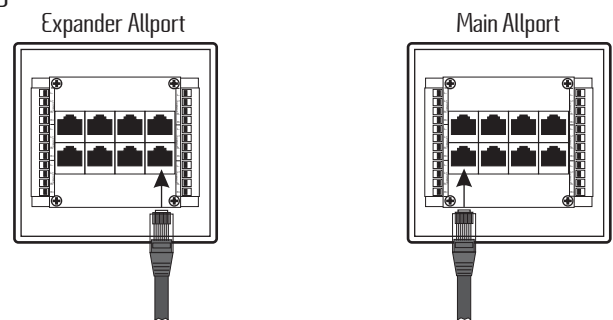
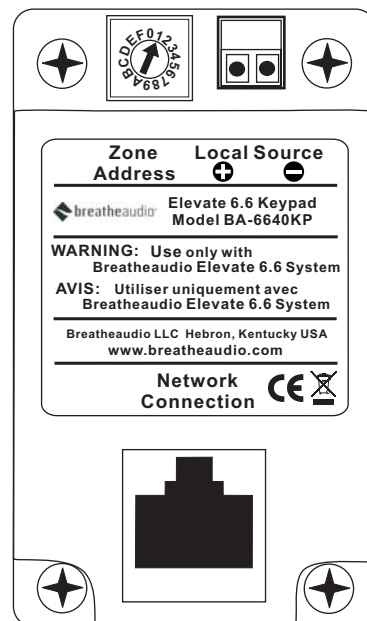

Fig. 8



The BA-NC3 is a standard network cable that is used to connect the Expander Allport keypads to the Main Allport keypads. Any open RJ-45 jack can be used for this.

Fig. 9



IX. Keypad Zone Settings

Each Elevate 6.6 keypad has the ability to set specific zone functions. These are bass and treble EQ, source grouping, all on (party mode) and volume reset. Each of these functions is accessed by pressing the MUTE and SOURCE 1,2,3,4 and 5 buttons simultaneously, fig. 10.

While the keypad is in the function set mode, the appropriate source button with flash. To return to normal zone control, press the flashing source button.

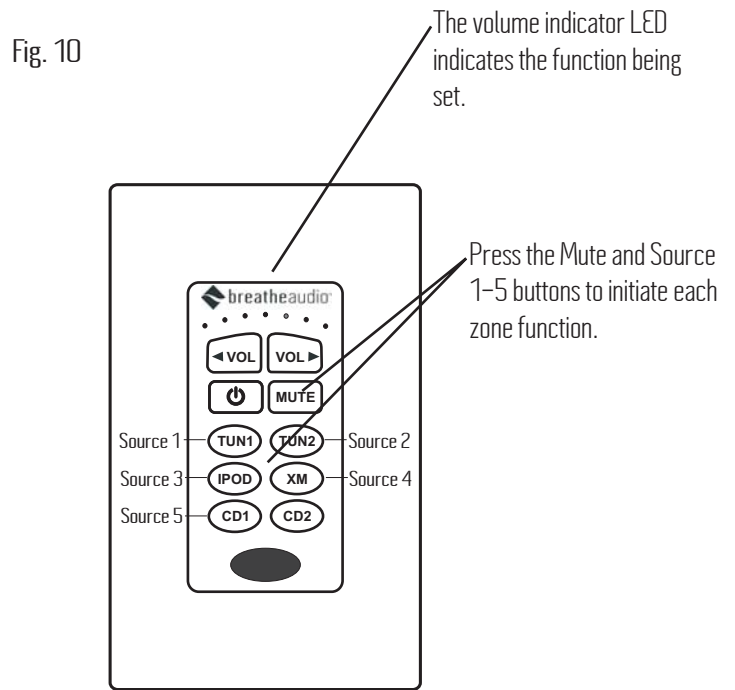

EQ Control and Source Grouping

To change bass response, press the Mute button and Source 1 button simultaneously. Adjust the bass level up or down by using the Volume Up and Volume Down buttons. The volume indicator LEDs will indicate the output level, fig. 8. Adjust treble response using the same process. This is accessed by pressing the Mute and Source 2 buttons. Once the desired setting is made, press the Source button again to return the keypad to normal operation.

Source grouping is a feature that allows multiple zones in an open living space to always share the same source selection but still retain individual volume and on/off control. This is achieved by pressing Mute and Source 3. Volume Up enables the group function, and Volume Down disables the group function and causes the keypad to operate independently of all other groups, fig. 12.

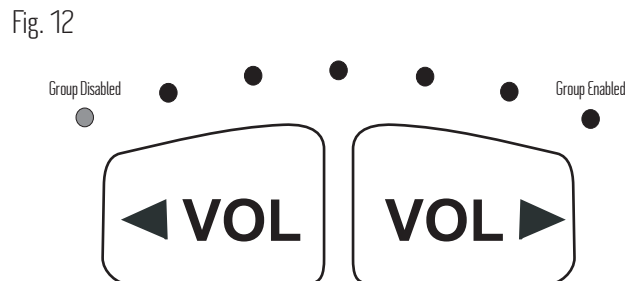
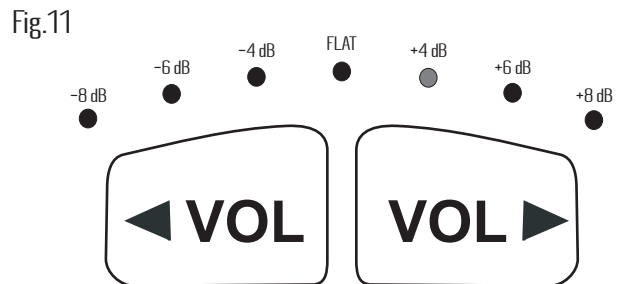

All On/Party Mode

The Elevate 6.6 System has an All On feature. Any keypad within the system, which can be up to twelve zones, has the ability to become a master control for the entire house. The master keypad will control zone on, volume level, and source selection for all other zones.

To place a keypad in Master Mode function, simply press the Mute and Source 4 buttons simultaneously. This will cause the volume indicator LED for that zone's keypad to flash continuously and adjust to a preset volume level (-60 dB). All other zones will then turn on to the same relative volume level and increase or decrease with the volume adjustment on the master keypad, fig. 13. Each keypad volume LED indicates a preset meter level threshold, fig. 14.

Any of the other zone keypads have the ability to override the master function by selecting a new source, changing a local zone's volume control, or by turning a local zone's keypad off and back on.

The master mode is turned off by repeating the sequence of pressing the Mute and Source 4 buttons.

Fig. 13

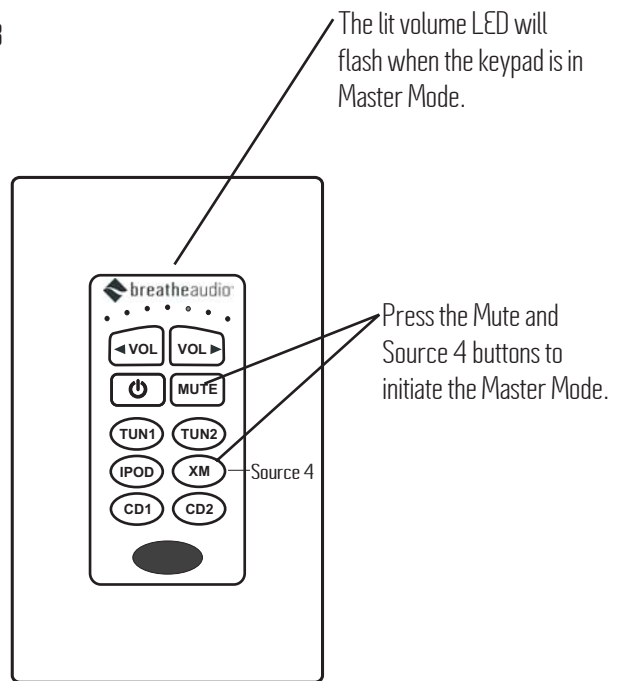
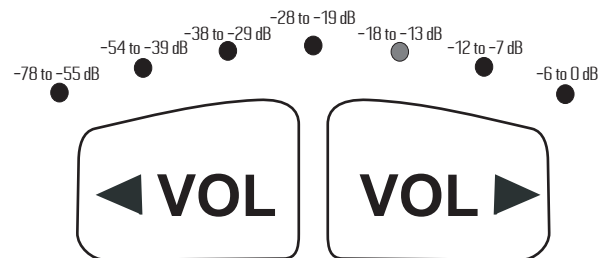

Fig. 14



Volume Reset

Each zone has the capability of turning on at two different volume level settings. At factory default the zone will turn on at the previous listening level. If desired, you can change that default to a low level volume reset regardless of the previous level.

To change the zone to volume reset mode, press the Mute and Source 5 buttons simultaneously. The Source 5 button will begin flashing. The volume LED will first appear at the far left indicating no volume reset. Pushing the Volume Up button will cause the volume LED to move to the far right position. This now indicates that the zone is in volume reset mode, fig. 15.

To return to normal keypad operation, press the Source 5 button again and it will stop flashing. In the volume reset mode the zone will automatically turn on at a preset -60 dB level. The volume reset can be turned off by repeating the above steps and returning the volume LED to the far left position.

Fig. 15

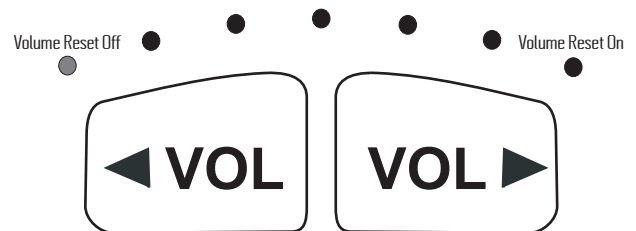

X. Using the Fixed and Variable Lineouts

The first four zones of the Elevate 6.6 amplifier have two 3.5mm mini stereo outputs. These are fixed and variable lineouts used for adding additional amplification when necessary for each zone. A distinct advantage to the Breatheaudio equipment is the ability to use the amplified output, variable and fixed lineouts on each of the first four zones simultaneously. The Elevate 6.6 amplifier has zone trigger outputs that provide a 12V trigger for additional amplification. This enables the attached amplifier to be triggered on and off with the zone keypad.

Zone Variable Lineout

The variable lineout is designed to allow additional audio amplification volume level to be controlled from that zone's keypad. When used in conjunction with the zone amplified output, fig. 16, all the speaker's volume will track with the keypad volume level.

Fig. 16

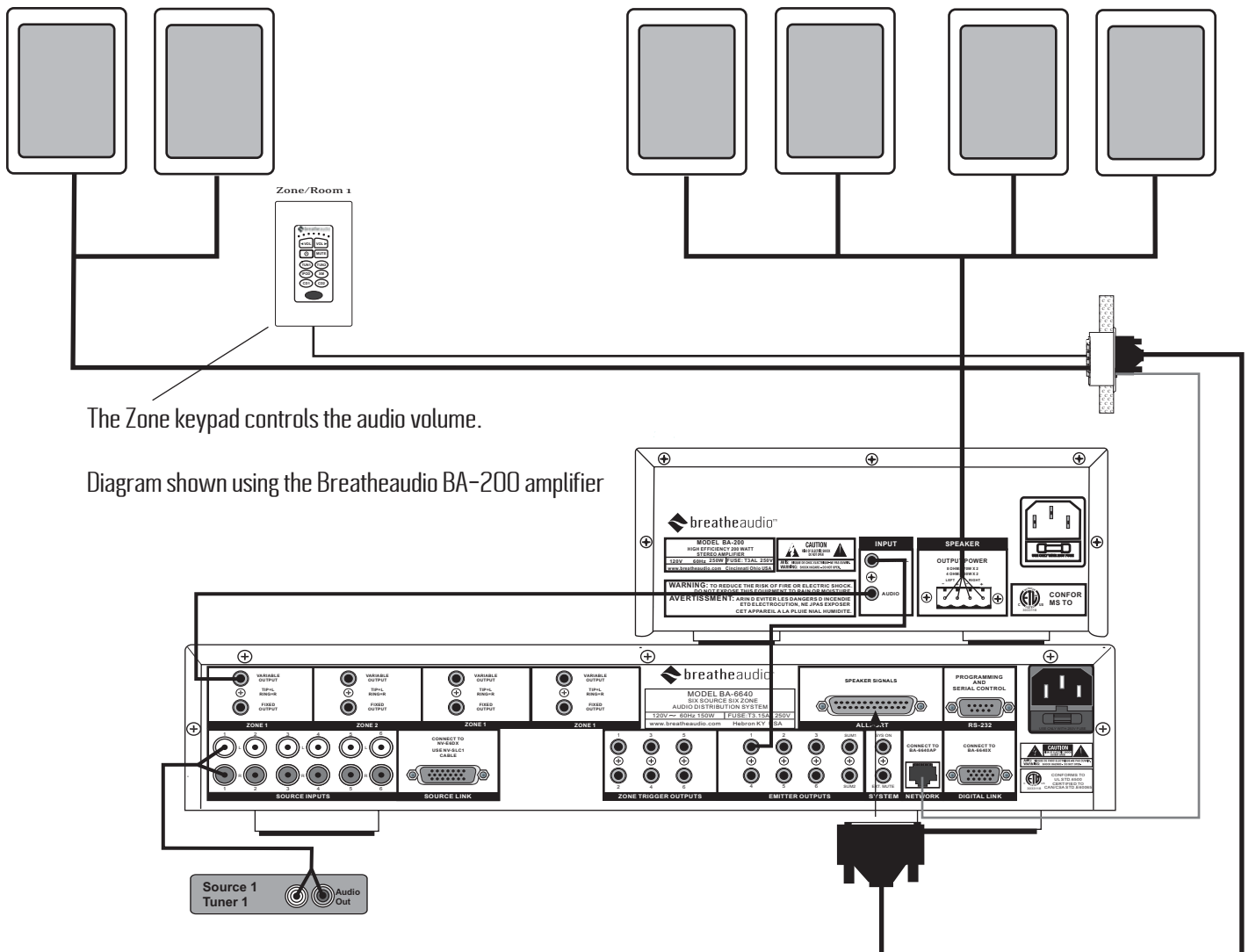

Zone Fixed Lineout

In some zone applications, it is more advantageous to have a separate volume control on the additional speakers being driven by an additional amplifier. This is common with outdoor zones. The fixed lineout offers the capability to add amplification, but the audio signal is not affected by the zone keypad volume level. Therefore, it requires a separate volume control for those speakers, fig. 17.

Fig. 17

Additional speakers are controlled by a separate volume control.

Diagram shown using the Breatheaudio BA-200 amplifier

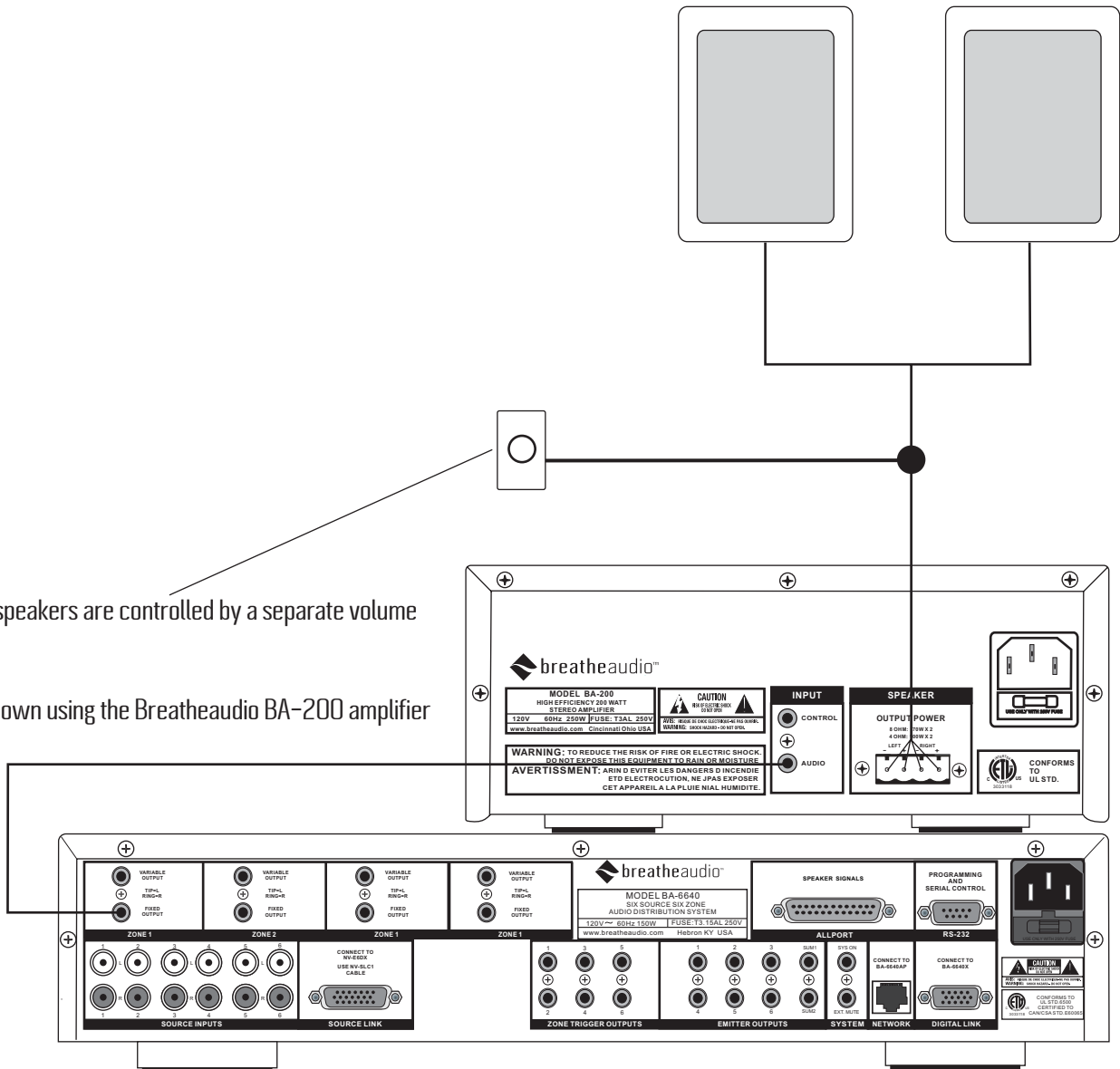

XVI. Pulse BA-200 200 Watt Auxiliary Amplifier

The BA-200 is specifically designed for use with the Breatheaudio Systems' lineouts. It can be used with either the fixed or variable lineouts on the Elevate 6.6 with either a 1/8" (3.5mm) to 1/8" stereo patch cable or a 1/8" stereo to RCA patch cable, Fig 18.

An additional feature of Elevate 6.6 is zone specific triggers that will trigger the BA-200 only when that zone is turned on.

Utilizing the voltage trigger requires a mono 1/8" (3.5mm) patch cable from either the System ON output on the Elevate 6.6 to the BA-200 Voltage trigger input, or from the specific Zone Trigger on the Elevate 6.6 to the Voltage Trigger on the BA-200, Fig. 19.

Fig. 18

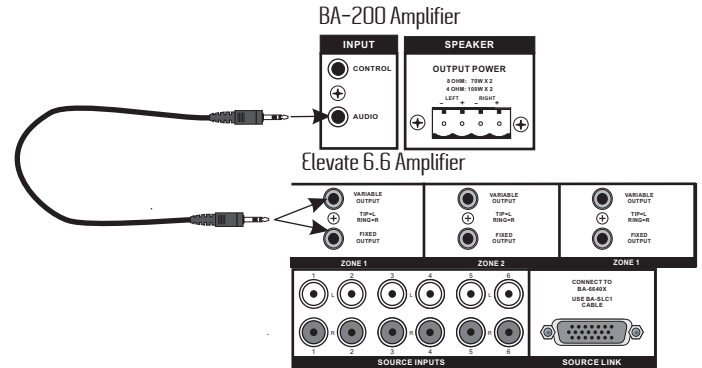
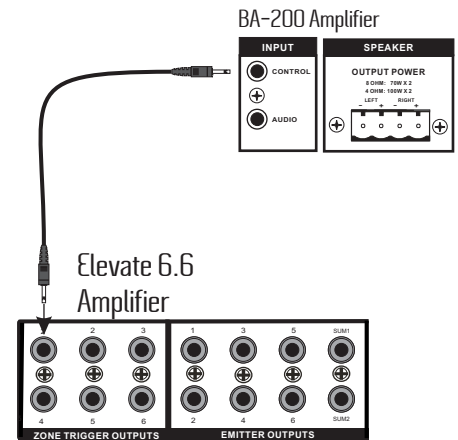

Fig. 19



RS232 Interface

The RS232 port allows external two-way communication with the Elevate 6.6 System. This can be used in conjunction with the many home automation control systems available on the market today to operate Elevate 6.6. The RS232 addendum contains the necessary command sets for communication with the Elevate 6.6 System.

Troubleshooting

Symptom

Probable Cause

Remedy

When the keypad is plugged in there is a loud pop through the speakers and the keypad does not work.

Improperly wired CAT5 cable.

Check that you are using the 568A or B wiring standard (see section I: Crimping CAT5 wire). The best way to know is to use a CAT5 tester. This can also be tested with the BA-AWT1 Allport Tester.

When the keypad is plugged in, it just flashes and has no functionality.

Duplicate address assigned to multiple keypads.

Each keypad must have a unique address set with the Zone Address rotary switch located on the back of the keypad (see section VII, Installing the Elevate 6.6 keypads).

The amplifier is plugged in and turned on, but the STAND BY LED is not lit and none of the system functions work.

This is most likely caused by a blown fuse on the power supply.

The fuse is accessed at the back of the amplifier where the AC cord plugs in. It requires a 4 amp time delay fuse.

All the keypads change when a source is selected on only one.

The keypads are set for Source Grouping.

Pressing the MUTE and Source 3 button simultaneously sets the Source Grouping feature. This will cause multiple keypads to always share the same source (see Section IX, Zone EQ and Source Grouping on page 11).

With the keypads plugged in, the POWER LED on the front of the amplifier will not turn on.

One or more improperly wired CAT5 cables.

Make sure the amplifier is turned on. Test that the POWER LED on the amplifier turns on when the Network Cable is unplugged. Next, unplug all the CAT5 cables from the Allport and plug them back in one at a time until the bad cable(s) is discovered.

The IR repeater does not properly control the audio source equipment.

One or more of the IR emitters are not properly placed over the IR receiver on the audio source equipment, or the IR output on the Elevate 6.6 does not correspond with the audio equipment you are controlling.

Reposition the LED end of the emitter on the face of the source equipment, so it is flashing directly over that source's IR receiver. Make sure that the emitter plugged into IR Output #1 is actually going to source #1, and so on for sources 2-6.



Elevate 6.6 Specifications

Zones 1-6 Power Amplifier Outputs

Continuous Average Output Power	40W (20W x 2)
Two channels driven 30-20kHz @1% THD	
Rated Distortion (1/2 power)	0.40%
Rated Impedance	6 Ohms
Damping Factor	50+
Frequency Response (20-20kHz)	±2 dB

Zones 1-4 Preamplifier Outputs

Variable output	0-600mV
Fixed output	600mV
Impedance	600 Ohms

Source Inputs 1-6

input Impedance	10K
Input Sensitivity for rated power	300mV RMS
Input Overload	3V RMS

Emitter Outputs

Source Outputs	6
Sum Outputs	2
Output Drive Current	30mA
Output Drive Voltage	12V
Compatible with single and dual emitters	

System

System On	12V @ 50mA
External Mute	3-12V DC

Zone Trigger Outputs

Output Power	12V @ 50mA
Outputs	6 (zones 1-6)

Power Requirements

Power Supply	120VAC/240VAC 50/60Hz
Power Consumption all channels driven to full-rated power	340VA (290W)
Power Consumption average operating conditions	50VA (40W)
Power Consumption no signal	30VA (12.5W)
USA Safety Listing (UL 6500)	
Canada Safety Listing (CAN/CSA E60065.00)	
CE Listing/SEMKO (EN60065, EN55013, EN55020, EN6100-3-2, EN6100-3-3/A1)	

Physical Specifications

Unit Size Millimeters	88 H x 430 W x 325 D
Unit Size Inches	3 1/2 H x 17 W x 12 3/4 D
Shipping Size Millimeters	290 H x 540 W x 440 D
Shipping Size Inches	11 3/8 H x 21 1/4 W x 17 3/8 D
Unit Weight Kilograms	7.8
Unit Weight Pounds	17.0
Shipping Weight Kilograms	12.7
Shipping Weight Pounds	28.0
Keypad Size Millimeters	107.2 H x 41.5 W x 32.5 D
Keypad Size Inches	4 1/4 H x 1 5/8 W x 1 1/4 D

BreatheAudio reserves the right to change specifications without notice.



Addendum

Control Interface Description Document for the Breatheaudio BA-6640 Main Unit Revision E (for Breatheaudio BA-6640 Mark II systems only) June 8, 2006

DB9M PORT PINOUTS: Breatheaudio Transmit to System Controller on pin 2.
Breatheaudio Receive from System Controller on pin 3.
Ground on pin 5.

SERIAL PORT PARAMETERS: RS232, RTS/CTS or software flow control (XON/XOFF) NOT required, 9600 baud, 8N1 protocol.

RULES OF PROTOCOL:

- (1) For alpha ASCII characters, always use UPPER CASE. In this document, actual characters in a string are presented in BOLD type.
- (2) All numerical fields are coded as ASCII digit characters.
- (3) Each Command string is STARTED with an ASCII "*" character and terminated by a <CR> character (0D hexadecimal). Each response string issued by the BA-6640 will START with an ASCII "#" and be terminated with a <CR> character (0D hexadecimal).
- (4) If a command has an error in it (does not adhere to exact command syntax), the BA-6640 will respond with a "#?<CR>" string.
- (5) Whenever queuing multiple commands to the BA-6640, the host program should pause for 50 milliseconds between commands to prevent buffer overruns.

NUVO POWER-ON STATE:

- (1) Each zone is OFF until ON command is received.
- (2) Each zone's ZoneSet status will be as set by the special key combination settings as detailed in the owner's manual. If no keypad is connected with a given zone address, then ZoneSet will default to:
 - A. OR0 (No override)
 - B. BASS+0 (Bass FLAT)
 - C. TREB+0 (Treble FLAT)
 - D. GRP0 (SOURCE GROUPING OFF)
 - E. VRST1 (VOLUME RESET TO 50 dB ON)

If these zone settings are overridden by the commands which follow in this document, the overridden values will reset to the default values above upon cycling power on the Main Unit.

- (3) For the first four seconds after power-on, a series of non-control related characters will be issued at a wide range of baud rates. These are necessary queries to a program that may be running on a connected PC for the purpose of Firmware field upgrades. They should be ignored by the host control system.

NON-VOLATILE COMMANDS AND ASSOCIATED RESPONSES With the exception of commands associated with setting the IR carrier frequency, the effect of all commands is non-permanent; i.e. when power is cycled on the main unit, it will return to default values. The commands that are an exception to this rule follow in this section.

COMMAND: *IRSETSR<CR> Reads status of SOURCE IR carrier frequency settings.

RESPONSE: #IRSET:aa,bb,cc,dd,ee,ff<CR> where:
aa = IR carrier frequency of SOURCE 1 ("38" or "56")
bb = carrier frequency of SOURCE 2 ("38" or "56")
cc = carrier frequency of SOURCE 3 ("38" or "56")
dd = carrier frequency of SOURCE 4 ("38" or "56")
ee = carrier frequency of SOURCE 5 ("38" or "56")
ff = carrier frequency of SOURCE 6 ("38" or "56")



NOTE: the Main Unit ships with the carrier frequency DEFAULT setting of 38 KHz for all six sources.

COMMAND: ***IRSETDF<CR>** Restores DEFAULT SOURCE IR carrier frequency settings (38 KHz for all six sources).
RESPONSE: Same response as for **#IRSETSR<CR>**

COMMAND: ***SxIR56SET<CR>** - sets SOURCE x to 56 KHz IR repeat carrier (x is 1 to 6).
RESPONSE: Same response as for **#IRSETSR<CR>**

COMMAND: ***SxIR38SET<CR>** - sets SOURCE x to 38 KHz IR repeat carrier (x is 1 to 6).
RESPONSE: Same response as for **#IRSETSR<CR>**

COMMAND/RESPONSE DESCRIPTIONS.

NOTE zone number field xx should ALWAYS include a lead zero ("0") for zone numbers less than 10.

COMMAND: ***ZxxCONSR<CR>** - Connect STATUS REQUEST where xx is zone # from 1 to 12.

RESPONSE: **#ZxxPWRppp,SRCs,GRPt,VOL-yy,Pzzz<CR>** -ppp = "ON" (2 characters)
or "OFF" (3 characters)

The remaining fields are not included in the response if ppp is "OFF":

- s = SOURCE NUMBER 1 to 6
- q = 0 if SOURCE GROUP is ON 1if SOURCE GROUP is OFF
- yy = level below max in dB: -00 to -78 dB (include lead 0 for all single-digit values)
- yy = "MT" if in MUTE state
- yy = "XM" if external MUTE is being held active
- zzz = "MST" if this zone is PARTY MASTER
- zzz = "SLV" if this zone is SLAVED to a PARTY MASTER in another zone
- zzz = "OFF" if this zone is under LOCAL CONTROL only (either there is no party master, or this zone has been manually overridden)

This response will also be issued in response to pressing the ON/OFF, VOLUME, or SOURCE keys on a KEYPAD. NOTE the response will be issued if a SOURCE key is pressed on a zone that is powered OFF even though the key press has no effect on the system. It will be output at every increment during a volume ramp initiated by HOLDING a VOLUME UP or VOLUME DOWN key on a keypad. It will also be issued at every increment of a volume ramp commanded by the ***ZxxVOL+<CR>** and ***ZxxVOL-<CR>** commands (see below).

The MUTE value will be asserted if a ***ZxMTON<CR>** command has been received, OR if the volume is run all the way to the lowest possible point (volume off). An active EXTERNAL MUTE input, however, will always override other volume response values with the "XM" response.



COMMAND: ***ZxxSETSR<CR>** ZoneSet STATUS REQUEST where xx is zone # from 1 to 12.
 RESPONSE: **#ZxxORp,BASSyy,TREByy,GRPq,VRSTu** -p = 1 if at least one of the permanent values have been overridden* by an RS232 command.
 -yy = EQ level, dB, 12 to +0 (flat) to +12 in 2 dB increments if set by RS232, -8, -6,-4, 0, +4, +6, +8 if set on keypad.
 -q = 0 if SOURCE GROUP is ON
 1 if SOURCE GROUP is OFF
 -u = 0 if VOLUME RESET is ON
 1 if VOLUME RESET is OFF

*override set to 1 FOR THIS ZONE only if one of commands ***ZxxBASSyy<CR>**, ***ZxxTREByy<CR>**, or ***ZxxGRPq<CR>** are issued (see descriptions below).
 Once a parameter has been SET by one of these commands, it will remain UNTIL:
 a. power is cycled on the Main Unit either with the front panel power switch or by removing AC power. Upon power-up, the system will restore keypad permanent settings (see the User Manual for details on how to perform these settings).
 b. an operator manually sets one of these parameters from a keypad. This takes the unit out of OVERRIDE state, but other RS232-commanded settings will remain until another RS232 command overrides them, or power is cycled.

This response is also issued whenever these parameters are set from a keypad.

COMMAND: ***ZxxON<CR>** Turn zone xx ON.
 RESPONSE: Same response as for ***ZxxCONSR<CR>**

COMMAND: ***ZxxOFF<CR>** Turn zone xx OFF.
 RESPONSE: Same response as for ***ZxxCONSR<CR>**

COMMAND: ***ALLOFF<CR>** Turn ALL zones OFF.
 RESPONSE: **#ALLOFF<CR>**

This RESPONSE is also issued when ALL OFF is pressed on any KEYPAD.

COMMAND: ***ALLV+<CR>** Ramp ALL zones UP at a 10 dB/second rate in 1 dB steps.
 RESPONSE: **#ALLV+<CR>**

The ramp action will be cancelled when all zones reach MAXIMUM volume, or when an ***ALLHLD<CR>** Command is received. Note that to stop the ramp with this command before maximum volume, one reference zone must be periodically polled with a ***ZxxCONSR<CR>** Command to determine when the desired volume point has been reached. Note that ramps in different zones may start at different levels and will all ramp at the same rate.



COMMAND: ***ALLV-<CR>** Ramp ALL zones DOWN at a 10 dB/second rate in 1 dB steps.
RESPONSE: **#ALLV-<CR>**

The ramp action will be cancelled when all zones reach MINIMUM (OFF) volume, or when an ***ALLHLD<CR>** Command is received. Note that to stop the ramp with this command before the minimum volume, one reference zone must be periodically polled with a ***ZxxCONSR<CR>** Command to determine when the desired volume point has been reached. Note that ramps in different zones may start at different levels and will all ramp at the same rate.

COMMAND: ***ALLHLD<CR>** Stops ramp action initiated by ***ALLV+<CR>** Or ***ALLV-<CR>**
RESPONSE: **#ALLHLD-<CR>**

This results in a HOLD of the level at time of command receipt.

COMMAND: ***ALLMON<CR>** ALL MUTE ON.
RESPONSE: **# ALLMON<CR>**

COMMAND: ***ALLMOFF<CR>** ALL MUTE OFF.
RESPONSE: **#ALLMOFF<CR>**

COMMAND: ***ZxxSRCp<CR>** Switch zone xx to SOURCE p (1 to 6).
RESPONSE: Same response as for ***ZxxCONSR<CR>**

COMMAND: ***ZxxVOLyy<CR>** Set volume of zone xx to level yy below max in dB from 0 to 78 dB (include lead 0 for all single-digit values).
RESPONSE: Same response as for ***ZxxCONSR<CR>**

COMMAND: ***ZxxVOL+<CR>** STARTS zone xx volume ramp UP at the rate of +10 dB per second in +1 dB steps. (This is the same as holding VOLUME UP key on a KEYPAD for 1 second).
RESPONSE: Same response as for ***ZxxCONSR<CR>**, updated 10 times per second.

COMMAND: ***ZxxVOL-<CR>** STARTS zone xx volume ramp DOWN at the rate of -10 dB per second in -1 dB steps. (This is the same as holding VOLUME UP key on a KEYPAD for 1 second).
RESPONSE: Same response as for ***ZxxCONSR<CR>**, updated 10 times per second.

COMMAND: ***ZxxVHLD<CR>** STOPS zone xx volume ramp initiated by ***ZxxVOL++<CR>** or ***ZxxVOL--<CR>** commands. This results in a HOLD of the level at time of command receipt.
RESPONSE: **#ZxxVHLD<CR>**

COMMAND: ***ZxxMTON<CR>** zone xx MUTE ON (mutes currently connected source)
RESPONSE: Same response as for ***ZxxCONSR<CR>**



COMMAND: ***ZxxMTOFF<CR>** zone xx MUTE OFF (returns zone output to currently connected source at previous volume setting).

RESPONSE: **Same response as for *ZxxCONSR<CR>**

COMMAND: ***ZxxBASSyyy<CR>** zone xx BASS EQ with yyy = EQ level, dB, 12 to +0 (flat) to +12 in 2 dB increments. USE LEAD "0" IN TENS PLACE FOR VALUE LESS THAN 10.

RESPONSE: **Same response as for *ZxxSETSR<CR>**

NOTE: sending this command to the BA-6640 will override the non-volatile BASS setting (set from keypad) for this zone until power is cycled.

COMMAND: ***ZxxTREByyy<CR>** zone xx TREBLE EQ with yyy = EQ level, dB, 12 to +0 (flat) to +12 in 2 dB increments. USE LEAD "0" IN TENS PLACE FOR VALUE LESS THAN 10.

RESPONSE: **Same response as for *ZxxSETSR<CR>**

NOTE: sending this command to the BA-6640 will override the non-volatile TREBLE setting (set from keypad) for this zone until power is cycled.

COMMAND: ***ZxxGRPON<CR>** zone xx SOURCE GROUP ON.

RESPONSE: **Same response as for *ZxxSETSR<CR>**

NOTE: sending this command to the BA-6640 will override the non-volatile GROUP setting (set from keypad) for this zone until power is cycled.

COMMAND: ***ZxxGRPOFF<CR>** zone xx SOURCE GROUP OFF.

RESPONSE: **Same response as for *ZxxSETSR<CR>**

NOTE: sending this command to the will override the non-volatile GROUP setting (set from keypad) for this zone until power is cycled.

COMMAND: ***ZxxVRSTON<CR>** zone xx VOLUME RESET ON.

RESPONSE: **Same response as for *ZxxSETSR<CR>**

NOTE: sending this command to the BA-6640 will set override (lock out KEYPAD non-address DIP switches) for this zone until power is cycled.

COMMAND: ***ZxxVRSTOFF<CR>** zone xx VOLUME RESET OFF.

RESPONSE: **Same response as for *ZxxSETSR<CR>**

NOTE: sending this command to the BA-6640 will set override (lock out KEYPAD non-address DIP switches) for this zone until power is cycled.

COMMAND: ***ZxxLKON<CR>** zone xx KEYPAD LOCK ON This will INHIBIT ANY keypad control input on the zone. This is the same as activating the Parental lock control at a keypad by holding down a SOURCE key for three seconds).

RESPONSE: **#ZxxLKON<CR>6**



COMMAND: ***ZxxLKOFF<CR>** zone xx KEYPAD LOCK ON This will RESTORE ALL keypad control input on the zone (useful as Parental lock control) . This is the same as deactivating the Parental lock control at a keypad by holding down a SOURCE key for three seconds).
RESPONSE: **#ZxxLKOFF<CR>**

COMMAND: ***VER<CR>** Firmware version query.
RESPONSE: **#NUVO_BA-6640_vx.yy<CR>** where x is the major version number and yy is the minor version number.

RESPONSE: **#EXTMON<CR>** Issued whenever the External MUTE first activates (closure to ground) and 0 whenever the External MUTE de-activates (open connection to ground).

NOTE: there is no COMMAND associated with this response; it is always initiated by a change at the EXT. MUTE input.

RESPONSE: **#EXTMOFF<CR>** Issued whenever External MUTE de-activates (open connection to ground).

NOTE: there is no COMMAND associated with this response; it is always initiated by a change at the EXT. MUTE input.



breatheaudio™
elevate



2395 Arbor Tech Dr
Hebron, KY 41048 USA
866.889.1019
www.breatheaudio.com