



DRY TO WET

USER'S GUIDE
5288 SERIES



3 Safety Instructions

4 Product View

5 Assembly

6-7 Operations

7-8 Maintenance and Care

9 TroubleShooting

10 Consumer Services

11 Replacement Parts

12 Warranty



Thanks for buying a BISSELL Hard Floor Cleaner

We're glad you purchased a BISSELL Flip-Ease™. Everything we know about floor care went into the design and construction of this complete, convenient cleaning system.

Your BISSELL Flip-Ease is well made, and we back it with a limited one-year warranty. We also stand behind it with a knowledgeable, dedicated Consumer Services department, so, should you ever have a problem, you'll receive fast, considerate assistance.

My great-grandfather invented the floor sweeper in 1876. Today, BISSELL is a global leader in the design, manufacture, and service of high quality homecare products like your BISSELL Flip-Ease.

Thanks again, from all of us at BISSELL.

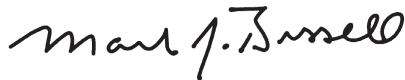

Mark J. Bissell
President and Chief Executive Officer



IMPORTANT SAFETY INSTRUCTIONS

When using an electrical appliance, basic precautions should be observed, including the following:

READ ALL INSTRUCTIONS BEFORE USING YOUR BISSELL FLIP-EASE CORDLESS HARD FLOOR CLEANER.

⚠ WARNING -
To reduce the risk of fire, electric shock, or injury:

- Store indoors.
- Do not expose to rain.
- Do not immerse.
- Do not handle with wet hands.
- Do not use Flip-Ease if it has been dropped, damaged, left outdoors or dropped into water. Have it repaired at an Authorized Service Center.
- Do not use with damaged cord or plug on the charger.
- Do not unplug charger by pulling on cord.
- Do not damage the charger cord. Never carry or pull the charger unit by the cord, use cord as a handle, close door on cord, or pull cord around sharp edges or corners. Keep cord away from heated surfaces.
- Do not use an extension cord. Charger should plug directly into electrical outlet.
- Do not put any object into appliance openings, use with blocked opening, or restrict air flow.
- Do not expose hair, loose clothing, fingers or body parts to openings or moving parts.
- Do not pick up hot, burning or smoking objects such as cigarettes, matches or hot ashes.
- Do not pick up flammable or combustible materials (lighter fluid, gasoline, kerosene, etc.) or use in the presence of explosive liquids or vapor.
- Do not use appliance in an enclosed space filled with vapors given off by oil base paint, paint thinner, some moth proofing substances, flammable dust, or other explosive or toxic vapors.
- Do not pick up toxic material (chlorine bleach, ammonia, drain cleaner, gasoline, etc.)
- Do not allow to be used as a toy. Close attention is necessary when used by or near children.
- Do not use for any purpose other than described in this User's Guide.
- Use only manufacturer's recommended

attachments - use of attachments not provided or sold by BISSELL may cause fire, electric shock or injury.

- Use only cleaning products formulated or recommended by BISSELL for this appliance.
- Use only the charger supplied by BISSELL (packaged with your appliance) to recharge your Flip-Ease.
- Use charger unit only in standard electrical outlet (120v-60 hz).
- Use charger in dry location only.
- Keep openings free of dust, lint, hair, etc.
- Unplug charger unit from outlet before maintenance or cleaning.
- Unplug by grasping the plug, not the cord.
- Be extra careful when cleaning stairs.
- Turn off all controls when finished cleaning.
- Do no charge the unit outdoors.

Your Flip-Ease contains rechargeable nickel cadmium batteries. Do not incinerate batteries as they can explode when exposed to high temperatures.

Battery cell leaks can occur under extreme conditions. If battery cell liquid comes in contact with the skin:

- Wash immediately with soap and water, then neutralize with a mild acid such as vinegar or lemon juice.
- If battery cell liquid gets into the eyes: Flush immediately with clean water for a minimum of 10 minutes.
- Seek medical attention.

SAVE THESE INSTRUCTIONS.

THIS MODEL IS FOR HOUSEHOLD USE ONLY.

Product View

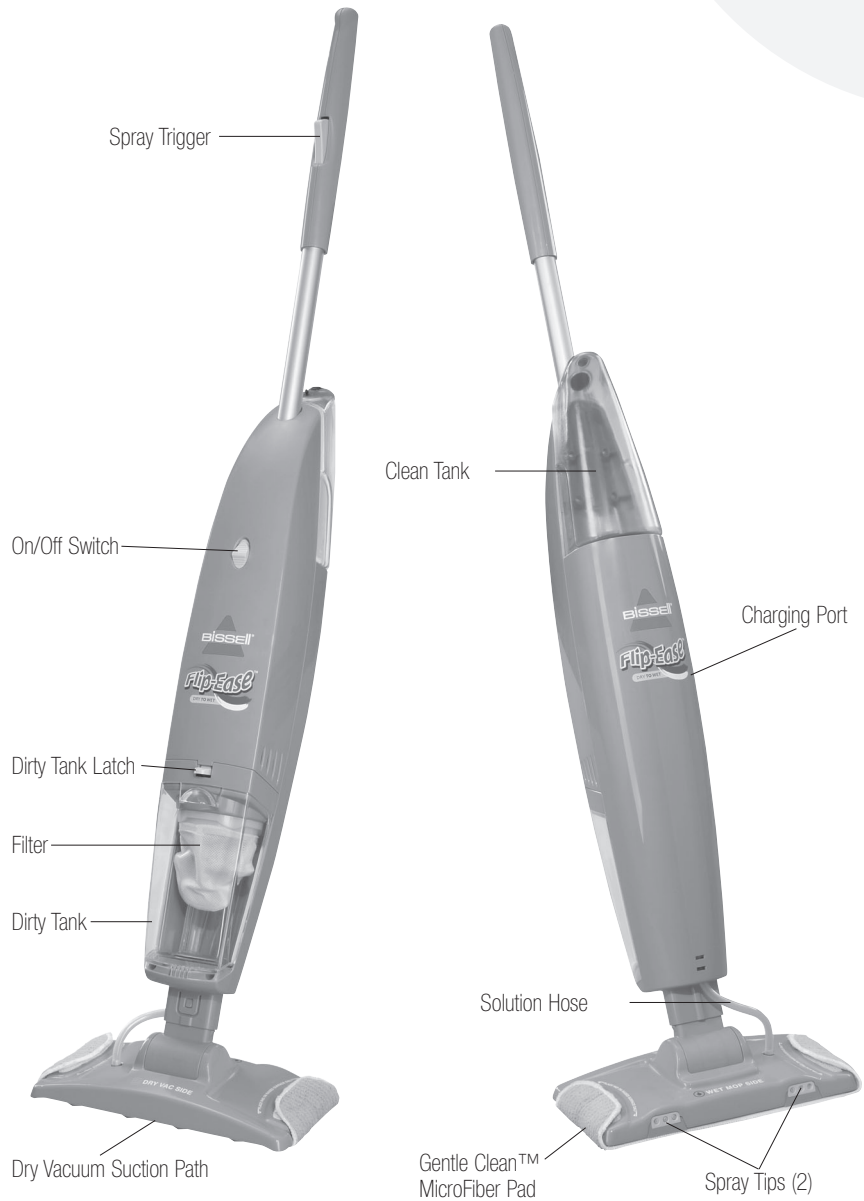

Assembling your Flip-Ease

Assembling your new Flip-Ease is a 3 Step Process, requiring no tools.

1. Insert foot into body of unit until you hear a click.
2. Place the Solution Tube onto the spray connector.
3. Insert the handle into the body of the unit. Turn handle until key in handle falls into position until you hear a "click".

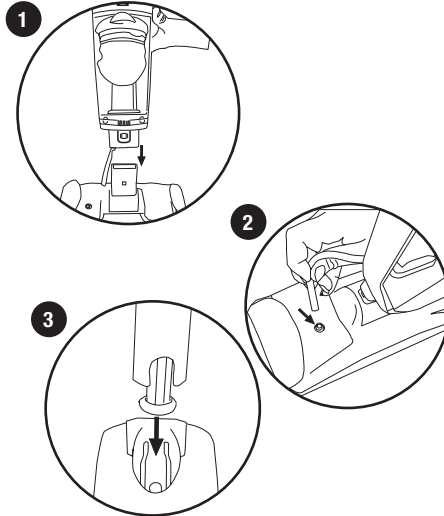

Charging

Note: The unit will come partially charged. Charge completely before using 12 hours or overnight.

Average run time for Dry Vacuuming is 12 minutes.

- A. To charge, place the charger plug into the Charging Port on the side of the unit. Make sure it is in securely and the charge indicator light is illuminated. Make sure power switch is in the "off" position.

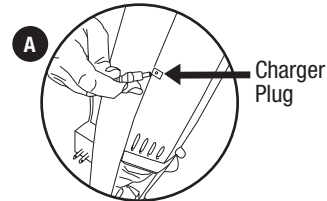

Filling the Clean Tank

1. Remove tank from the unit.
2. Unscrew the black cap on the bottom of the solution tank and remove the insert.
3. Fill with Tap Water to the full line and fill the remainder with BISSELL formula. Replace the cap and insert assembly. Place the full tank back into the unit.

Tip:

You will only utilize battery charge while dry vacuuming. For wet mopping, the batteries are not used, extending usage time.

Tip:

Gently push the tank into place. If you see air bubbles in the tank, it is seated properly.

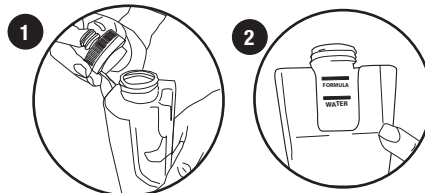

How to use your Flip-Ease

Dry Vac

1. Attach the Gentle Clean™ MicroFiber pad onto the base of the unit. Begin by attaching the pad onto the Velcro on one side of the unit, wrapping it under the foot and attaching on the other side

Tip: If the MicroFiber covers the vacuum suction path, the unit will not suction.

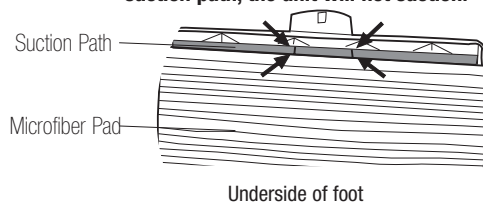

2. Turn the unit on.
3. With the Dry Vac side of the unit facing forward, begin cleaning. You will see dry dirt, crumbs and debris being collected in the Dirty Tank.
4. Check the filter frequently. If you see hair and fuzzy debris collecting on the filter, remove the dirty tank and dirty tank lid to clean the filter.

To clean the filter, gently tap it on the edge of the trash can, brushing off anything that may be sticking to the filter. The filter can also be rinsed with warm water. Let air dry before inserting back into the unit.

Tip:

The MicroFiber pad should be placed in the areas directed. Covering the vacuum suction path will stop all suction.

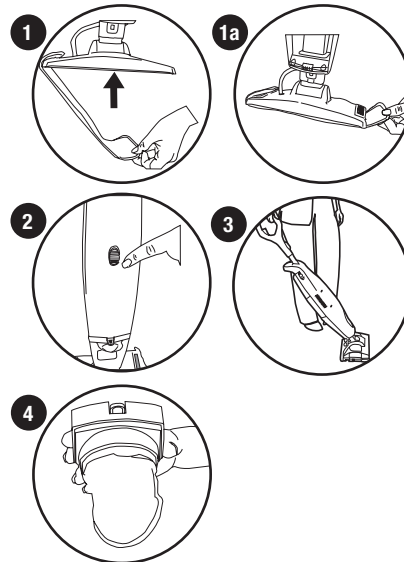

How to use your Flip-Ease Continued

Switching from Dry Vac to Wet Mop

1. To change from dry vacuuming to wet cleaning simply flip the unit around!

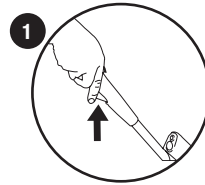
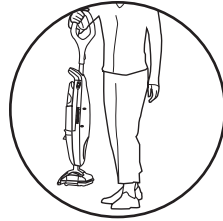

Tip:
When the trigger is squeezed the vacuum suction will stop; extending battery life.

Wet Mop

1. By squeezing the trigger, you will turn off the vacuum suction.
2. Water and Solution will flow to the 2 spray tips on the Wet Mop side. Gently mop the floor with the Gentle Clean™ MicroFiber pad. Depressing the trigger will dispense water and solution based on your cleaning job.
Sticky, dirty areas may require more water and solution.

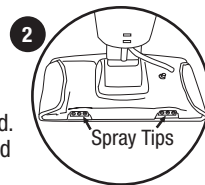

Tip:
You do not have to empty the Dirty Tank before wet mopping.

Floor will need to air dry for 3-5 minutes.

Cleaning the Gentle Clean™ MicroFiber Pad

1. After Wet Mopping, remove the MicroFiber Pad to launder or wash.

To wash, simply toss in the wash, air dry and reuse. No need to buy disposable cloths every time you use your Flip-Ease!

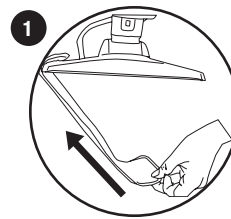

Maintenance and Care

Storing and Charging your Flip-Ease

Your Flip-Ease can be stored Ready-to-Use, by leaving water and formula in the Clean Tank.
Be sure to remove the MicroFiber Pad to clean.

1. To charge while storing, place the charger plug into the charging port on the side of the unit. Make sure it is securely connected and the charger indicator light is illuminated.

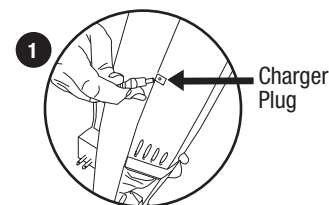

Battery Removal And Disposal



1. Important: Unplug charger.
2. Remove tanks (clean and dirty) and discard.
3. Remove screws (6) holding Product Housing together (see diagram).
4. Use screwdriver to score Rating Label on side of unit.
5. Separate Housings and locate Battery Pack in bottom/ center of unit.
6. Remove wires from the Battery Pack.
7. Keep Battery Pack together - DO NOT separate individual batteries. For specific disposal instructions of batteries, please contact:
RBRC (Rechargeable Battery Recycling Corporation)
1-800-822-8837.
8. Discard remainder of product.

⚠ WARNING:

This product contains a rechargeable nickel cadmium battery (sometimes referred to as a "Ni-Cad" battery) pack. The average life of a Ni-Cad battery is 5-7 years, depending on frequency of use. According to Federal regulations, proper removal and disposal of Ni-Cad batteries are required.

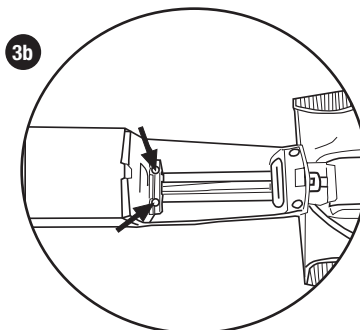
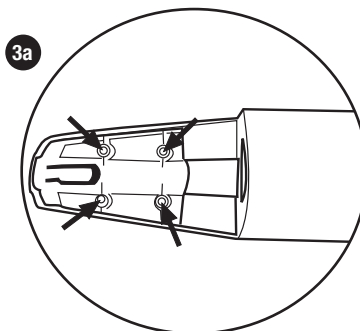

Troubleshooting

Problems

1. No suction or unit will not turn on
2. No or low suction
3. No Spray



WARNING:

To reduce the risk of electric shock, turn power OFF and disconnect charger from electrical outlet before performing maintenance or troubleshooting.

Possible Causes

1. Unit is not charged
2. Batteries are run down
Filter Clogged
Dirty Tank not properly installed
MicroFiber pad covering suction path
Clogged suction path
Foot not properly installed
3. Clean Tank is empty
Clean Tank is not inserted properly
Handle is not properly inserted
Solution tube not connected to foot

Other maintenance or service not included above should be performed by an authorized service representative.

Thank you for selecting a BISSELL product.

If you should happen to need assistance during assembly or operations, call 1-800-237-7691

Please do not return this product to the store

For any questions or concern, BISSELL is happy to be of service.

Contact us directly at 1-800-237-7691.

BISSELL Consumer Services

For information about repairs or replacement parts, or questions about your warranty, call:

BISSELL Consumer Services

1-800-237-7691

Monday - Friday 8 a.m. — 10 p.m. EST

Saturday 9 a.m. — 8 p.m. EST

Or write:

BISSELL HOMECARE, INC

PO Box 3606

Grand Rapids MI 49501

ATTN: Consumer Services

Or visit the BISSELL website - **www.bissell.com**

When contacting BISSELL, have model number of cleaner available.

Please record your Model Number: _____

Please record your Purchase Date: _____

NOTE: Please keep your original sales receipt. It provides proof of date of purchase in the event of a warranty claim. See Warranty on page 8 for details.

Replacement parts - BISSELL Flip-Ease™ Hard Floor Cleaner

You may purchase parts from your retailer, by calling BISSELL Consumer Services or by visiting our website. Below is a list of common replacement parts*. While not all of these parts may have come with your specific model, they are available for purchase if desired. Please note, all attachments may not store on board your vacuum.

Item	Part No.	Part Name
1	203-6917	Handle Assembly
2	203-6918	Solution Tank (w/ cap & insert)
3	203-6919	Solution Tank cap & insert
4	203-6920	Collection Tank
5	203-6922	Collection Tank Lid
6	203-6924	Filter
7	203-6912	Pad
8	203-6926	Charger
9	0484	32 oz. Hard Floor Solutions

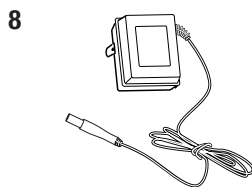
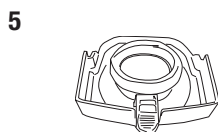
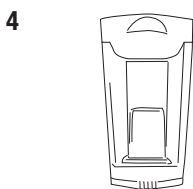
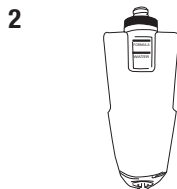
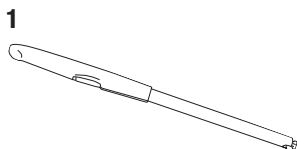

Warranty - BISSELL Flip-Ease™

This warranty gives you specific legal rights; and you may also have other rights which may vary from state to state. If you need additional instruction regarding this warranty or have questions regarding what it may cover, please contact BISSELL Consumer Services by E-mail, telephone, or regular mail as described below.

Limited One Year Warranty

Subject to the ***EXCEPTIONS AND EXCLUSIONS** identified below, upon receipt of the product BISSELL Homecare, Inc. will repair or replace (with new or remanufactured components or products), at BISSELL's option, free of charge from the date of purchase by the original purchaser, for one year any defective or malfunctioning part.

See information below on "If your BISSELL product should require service".

This warranty applies to product used for personal, and not commercial or rental service. This warranty does not apply to fans or routine maintenance components such as filters, belts, or brushes. Damage or malfunction caused by negligence, abuse, neglect, unauthorized repair, or any other use not in accordance with the User's Guide is not covered.

If your BISSELL product should require service:

Contact BISSELL Consumer Services to locate a BISSELL Authorized Service Center in your area.

If you need information about repairs or replacement parts, or if you have questions about your warranty, contact BISSELL Consumer Services.

Website or E-mail:

www.bissell.com

Use the "Customer Services" tab.

Or Call:

BISSELL Consumer Services

1-800-237-7691

Monday - Friday 8 a.m. - 10 p.m. ET

Saturday 9 a.m. - 8 p.m. ET

Or write:

BISSELL Homecare Inc.

PO Box 3606

Grand Rapids MI 49501

ATTN: Consumer Services

BISSELL HOME CARE, INC. IS NOT LIABLE FOR INCIDENTAL OR CONSEQUENTIAL DAMAGES OF ANY NATURE ASSOCIATED WITH THE USE OF THIS PRODUCT. BISSELL'S LIABILITY WILL NOT EXCEED THE PURCHASE PRICE OF THE PRODUCT.

Some states do not allow the exclusion or limitation of incidental or consequential damages, so the above limitation or exclusion may not apply to you.

***EXCEPTIONS AND EXCLUSIONS FROM THE TERMS OF THE LIMITED WARRANTY**
THIS WARRANTY IS EXCLUSIVE AND IN LIEU OF ANY OTHER WARRANTIES EITHER ORAL OR WRITTEN. ANY IMPLIED WARRANTIES WHICH MAY ARISE BY OPERATION OF LAW, INCLUDING THE IMPLIED WARRANTIES OF MERCHANTABILITY AND FITNESS FOR A PARTICULAR PURPOSE, ARE LIMITED TO THE ONE YEAR DURATION FROM THE DATE OF PURCHASE AS DESCRIBED ABOVE.

Some states do not allow limitations on how long an implied warranty lasts, so the above limitation may not apply to you.



©2006 BISSELL Homecare, Inc.
Grand Rapids, Michigan
All rights reserved. Printed in China
Part Number 603-6913
Rev 6/06
Visit our website at:
www.bissell.com

