

AVIOM[®]

6416*m*
Mic Input Module

RCI
Remote Control Interface

MCS
Mic Control Surface

User Guide

Certifications

ETL/cETL Listed

EMC: EN 55013, EN 55020, SAA AS/NZS 1053

Conforms to: IEC 60065, EN 60065, UL 6500-2001

Certified to: CAN/CSA E60065, KETI

RoHS Status: Pb-free



Notice of Rights

All rights reserved. No part of this document may be reproduced or transmitted in any form or by any means—electronic, mechanical, photocopy, recording, or otherwise—without written permission of Aviom, Inc.

Trademarks

Aviom, A-Net, the A-Net icon, Pro16, Pro64, and Virtual Data Cable are trademarks of Aviom, Inc.

All other trademarks are the property of their respective owners.

© 2009 Aviom, Inc. All rights reserved.

Information subject to change without notice.



READ THIS FIRST

Important Safety Instructions



1. Read these instructions.
2. Keep these instructions
3. Heed all warnings.
4. Follow all instructions.
5. Do not use this apparatus near water.
6. Clean only with a dry cloth.
7. Do not block any ventilation openings. Install in accordance with the manufacturer's instructions.
8. Do not install near any heat sources such as radiators, heat registers, stoves, or other apparatus (including amplifiers) that produce heat.
9. Do not defeat the safety purpose of the polarized or grounding-type plug. A polarized plug has two blades with one wider than the other. A grounding type plug has two blades and a third grounding prong. The wide blade or third prong are provided for your safety. If the provided plug does not fit your outlet, consult an electrician for replacement of the obsolete outlet.
10. Protect the power cord from being walked on or pinched, particularly at plugs, convenience receptacles, and the point where they exit the apparatus.



11. Only use attachments/accessories specified by the manufacturer.
12. Use only with the cart, stand, tripod, bracket, or table specified by the manufacturer, or sold with the apparatus. When a cart is used, use caution when moving the cart/apparatus combination to avoid injury from tip-over.
13. Unplug this apparatus during lightning storms or when unused for long periods of time.
14. Refer all servicing to qualified personnel. Servicing is required when the apparatus has been damaged in any way, such as when the power-supply cord or plug is damaged, liquid has been spilled or objects have fallen into the apparatus, the apparatus has been exposed to rain or moisture, does not operate normally, or has been dropped.
15. No on/off power switches are included in the system. The external power supply should be used to control power to an Aviom device. This power supply should remain readily operable.
16. The solid line over dashed line symbol () indicates that the input voltage must be a DC voltage.
17. The box within a box symbol () indicates that the external power supply is double insulated.



WARNING!



TO REDUCE THE DANGER OF ELECTRICAL SHOCK DO NOT REMOVE COVERS.

NO USER SERVICEABLE PARTS INSIDE

REFER SERVICING TO QUALIFIED SERVICE PERSONNEL ONLY

To reduce the risk of fire or electrical shock, do not expose this product to rain or other types of moisture.

To avoid the hazard of electrical shock, do not handle the power cord with wet hands.

Replace fuse with same type and rating.

Operating Temperature: 10°C to 50°C (50°F to 122°F)

Risque de choc électrique – ne pas ouvrir. Pour réduire le risque de feu ou de choc électrique, ne pas exposer cet équipement à la pluie ou la moisissure. Pour réduire le risque de choc électrique, ne pas retirer le couvercle. Pièces non remplaçables par l'utilisateur. Confier la réparation à une personne qualifiée. Attention – utiliser seulement un fusible de rechange de même type.

Cet appareil est conforme à la section 15 de la norme FCC. Son fonctionnement est soumis aux conditions suivantes : (1) cet équipement ne doit pas causer des interférences nocives, et (2) cet équipement doit accepter toute interférence captée incluant les interférences pouvant causer des opérations indésirables.

Cet appareil numérique de Classe B est conforme à la norme NMB-003 du Canada.

CAUTION:

- Using any audio system at high volume levels can cause permanent damage to your hearing.
- Set your system volume as low as possible.
- Avoid prolonged exposure to excessive sound pressure levels.

IMPORTANT:

This equipment has been tested and found to comply with the limits for a Class B digital device, pursuant to part 15 of the FCC Rules. These limits are designed to provide reasonable protection against harmful interference in a residential installation. This equipment generates, uses and can radiate radio frequency energy and, if not installed and used in accordance with the instructions, may cause harmful interference to radio communications. However, there is no guarantee that interference will not occur in a particular installation. If this equipment does cause harmful interference to radio or television reception, which can be determined by turning the equipment off and on, the user is encouraged to try to correct the interference by one or more of the following measures:

- Reorient or relocate the receiving antenna.
- Increase the separation between the equipment and receiver.
- Connect the equipment into an outlet on a circuit different from that to which the receiver is connected.
- Consult the dealer or an experienced radio/TV technician for help.

Changes or modifications to the product not expressly approved by Aviom, Inc. could void the user's FCC authority to operate the equipment.

Aviom, Inc. Limited Warranty

Aviom, Inc. warrants this product against defects in materials and workmanship for a period of **one year** from the date of the original retail purchase.

This warranty does not apply if the equipment has been damaged due to misuse, abuse, accident, or problems with electrical power. The warranty also does not apply if the product has been modified in any way, or if the product serial number has been damaged, modified, or removed.

If a defect is discovered, first write or call Aviom, Inc. to obtain a Return Authorization number. No service will be performed on any product returned without prior authorization. Aviom, Inc. will, at its option, repair or replace the product at no charge to you. The product must be returned during the warranty period, with transportation charges prepaid to Aviom, Inc., 1157 Phoenixville Pike, Suite 201, West Chester, PA 19380. You must use the product's original packing materials for shipment. Shipments should be insured for the value of the product. Include your name, address, phone number, description of the problem, and copy of the original bill of sale with the shipment. The Return Authorization number should be written on the outside of the box.

THIS LIMITED WARRANTY GIVES YOU SPECIFIC LEGAL RIGHTS. YOU MAY HAVE OTHER RIGHTS, WHICH VARY FROM STATE TO STATE (OR JURISDICTION TO JURISDICTION). AVIOM'S RESPONSIBILITY FOR MALFUNCTIONS AND DEFECTS IN HARDWARE IS LIMITED TO REPAIR AND REPLACEMENT AS SET FORTH IN THIS LIMITED WARRANTY STATEMENT. ALL EXPRESS AND IMPLIED WARRANTIES FOR THE PRODUCT, INCLUDING BUT NOT LIMITED TO ANY IMPLIED WARRANTIES OF MERCHANTABILITY AND FITNESS FOR A PARTICULAR PURPOSE, ARE LIMITED IN DURATION TO THE WARRANTY PERIOD SET FORTH ABOVE. NO WARRANTIES, WHETHER EXPRESS OR IMPLIED, WILL APPLY AFTER SUCH PERIOD.

AVIOM, INC. DOES NOT ACCEPT LIABILITY BEYOND THE REMEDIES SET FORTH IN THIS LIMITED WARRANTY DOCUMENT. AVIOM, INC.'S LIABILITY IS LIMITED TO THE REPAIR OR REPLACEMENT, AT OUR OPTION, OF ANY DEFECTIVE PRODUCT, AND SHALL IN NO EVENT INCLUDE INCIDENTAL OR CONSEQUENTIAL DAMAGES OF ANY KIND.

SOME STATES DO NOT ALLOW EXCLUSIONS OR LIMITATION OF IMPLIED WARRANTIES OR LIABILITY FOR INCIDENTAL OR CONSEQUENTIAL DAMAGES, SO THE ABOVE LIMITATIONS MAY NOT APPLY TO YOU.

Warranty Information

Please record the following information for future reference:

Your Authorized Aviom Dealer:

Name: _____

Address: _____

Phone: _____

Serial Numbers of Your Aviom Products: _____

Date of Purchase: _____

Your Authorized Aviom Dealer is your primary source for service and support. The information recorded above will be helpful in communicating with your Authorized Aviom Dealer should you need to contact Aviom Customer Service. If you have any questions concerning the use of this unit, please contact your Authorized Aviom Dealer first. For additional technical support, or to find the name of the nearest Authorized Aviom Repair Station, check the Aviom web site at www.aviom.com.

To fulfill warranty requirements, your Aviom product should be serviced only at an authorized Aviom service center. The Aviom serial number label must appear on the outside of the unit, or the Aviom warranty is void.

This manual and its contents are copyrighted by Aviom, Inc. All rights are reserved by Aviom, Inc. This document may not, in whole or in part, be copied, photocopied, reproduced, translated, or reduced to any electronic medium or machine-readable form without prior written consent from Aviom, Inc.

The software and/or firmware contained within Aviom products is copyrighted and all rights are reserved by Aviom, Inc.

Although every effort has been made to ensure the accuracy of the text and illustrations in this manual, no guarantee is made or implied as to the accuracy of the information contained within.

Table of Contents

Welcome	1
Features	1
The EtherCon Connector	2
AC Power	3
AC Line Conditioning	3
Rack Mounting	3
Transporting the 6416m in a Rack	4
Ventilation	4
Cleaning	4
About A-Net	5
Clocking	5
Control Data	6
A-Net Ports	6
Support For Pro16 Series Products	7
Firmware Notice	8
Pro64 Interface Conventions	9
Cat-5e	9
Button Presses	9
Changing Values	9
Selecting Values	10
DIP Switches	10
Pro64 User Interface	11
Basic Actions	11
A-Net Slot	12
Slots versus Channels	12
Slots and Sample Rate	13
A-Net Slot Example	16
Network Modes	18
Auto Mode	18
Manual Mode	18
Pro64 Network Concepts	20
Control Master	20
Setting Control Master Status	21
Control Master Functions	21
Enumeration	21
Adding Pro64 Modules to a Network	22
Changing Settings	22
Control Master and Clock Source	23
Clock Errors	24
Network Sample Rate	24
Changing the Sample Rate	25
Auto/Manual Mode Selection	25
Changing the Network Mode	26
Managed Mode	26

Password Protection	27
6416m Front Panel Components	29
6416m Rear Panel Components	32
6416m Network Settings	34
Control Master	34
Control Master Errors	34
A-Net Slot Range Configuration	35
Setting the A-Net Slot Range	35
Network Mode	36
A-Net Transmit	36
Changing the A-Net Transmit Port	37
Clock Master	37
Sample Rate	37
Changing the Sample Rate	38
Sample Rates and A-Net Slots	39
6416m Front Panel Features	40
A-Net Slot Configuration	40
A-Net Transmit	40
Clock Master	41
Sample Rate	41
Function Button	41
Control Master LED	41
VDC Slot and Port Configuration	42
Enter/Cancel Buttons	42
A-Net LED	42
Managed Button	43
Edit Lock Button	43
Query Functions (Get Info)	44
Control Group	45
6416m Channel Strip Functions	46
Channel Activation Button	46
Channel Activation Rules	47
Level Meter LEDs	47
Stereo Link Button	47
Mute Button	48
Edit Button	49
Phase Button	49
Low Cut Button	50
Pad Button	50
+48V Phantom Power Button	51
Channel Gain	52
Gain Display	52
Control Group	52
Mic Preamp Presets	54
Save a Preset	54

Recall a Preset	55
Preset Rules.	55
6416m Rear Panel Features	56
AC Power	56
Fuse	56
Backup DC Power	56
6416m DC Requirements	56
A-Net Ports	57
Balanced Mic/Line Inputs	57
DB25 Audio Thru/Alternate In	58
Alternate Input	58
DB25 Pinout	58
Virtual Data Cables	60
Configuring a VDC	60
GPIO	61
GPIO Configuration DIP Switches	61
GPIO Terminal Blocks	62
MIDI In, MIDI Out	62
RS-232 Port	62
RS-232 Configuration DIP Switches	63
RS-232 Baud Rates	63
RCI Front Panel Components	66
RCI Rear Panel Components	68
RCI Front Panel Features	69
Headphone Input Jack	69
Monitor Volume Control	69
Network Mode Selection	69
A-Net Slot	70
Sync Indicator	71
Control Group Selection	71
A-Net LED	71
Controller Input for MCS	72
Cables Connecting the RCI and MCS	72
RCI Rear Panel Features	73
AC Power	73
Fuse	73
Backup DC Power	73
Balanced Line-Level Monitor Output	74
Output Pad Switch	74
A-Net Ports	74
MCS Components	76
MCS Features	78
Channel Level Meters	78
Numeric Keypad	78
Inc/Dec Selection Buttons.	78
A-Net Slot Display.	79
Select a Slot	79

No Control Indicator	80
Save and Recall Buttons	80
Cancel and Enter Buttons	81
MCS Channel Strip	81
Gain Display	81
Gain Control	82
Mute Button	82
Phase Button	82
Low Cut Button	83
+48V Phantom Power Button	84
Controller Connector	85
Cables Connecting the MCS and RCI	85
Building a Pro64 Network	86
Choosing a Network Mode	86
Connecting Pro64 Modules	86
Basic Routing	86
Auto Mode Connections	87
Digital Copies in Auto Mode	88
Adding a Merger Hub in Auto Mode	89
Manual Mode Connections	90
Digital Copies in Manual Mode	94
VDC Configuration	97
VDC Slot Display	97
VDC In Use LED	98
Assigning a VDC Slot	99
Deactivate an Active VDC Slot	99
Advanced Functions	100
Function Button	100
Clear A-Net Resources	101
Mute/Unmute all Channels	101
Password Lock	101
Password Unlock	102
Set a New Password	102
Sample Alignment	103
Measure New Sample Alignment Value	104
Use Stored Sample Alignment Value	104
Use Default Sample Alignment Value	105
Restore Factory Defaults	105
Firmware Update	107
Update Connections	107
Firmware Update - Local	107
Error Recovery	108
Firmware Update - via A-Net	108
6416m Block Diagram	110
6416m Specifications	111
Dimensions - 6416m	113
RCI Specifications	115

Dimensions - RCI116
MCS Specifications.118
Dimensions - MCS119
Mounting the MCS121
GPIO Specifications	122
GPIO Plugs	123
MIDI/GPIO Cable Lengths.	123
DB25 Audio Connections124
Wiring an Analog DB25 Cable124
DB25 Panel-Mount Connector Pinout124
Using DB25 Jacks	125
RS-232 Cables and Pinout126
RS-232 Connections.126
Wiring a Crossover Cable127
Warranty Registration135

Welcome

Thank you for purchasing the **6416m Mic Input Module, RCI Remote Control Interface**, and **MCS Mic Control Surface**. All Pro64 products are powered by A-Net®, Aviom's proprietary data transmission protocol designed especially for the unique demands of live streaming audio.

In developing the Pro64 Series, we have made every effort to make the user interface as easy to use and understand as possible. This User Guide is designed to familiarize you with the features and functions of your new Pro64® products. We encourage you to read the manual completely, as some of the powerful features of your new product may not be immediately apparent.

This combined User Guide covers the use and operation of the 6416m, RCI, and MCS.

Features

All Pro64 Series products provide a host of professional features designed to make A-Net audio networking with Pro64 Series products easy to set up and configure in a variety of professional audio situations.

6416m Mic Input Module Features:

Sixteen state-of-the-art mic preamp channels

- Remote controllable using the optional RCI Remote Control Interface and MCS Mic Control Surface
- Support for m-control™ for Yamaha® digital consoles with the 6416Y2 A-Net Interface Card installed
- XLR input jacks
- DB25 Audio Thru/Alternate In connections
- Mute, phase, low cut, +48V phantom power, and pad per channel
- Link switches for stereo channel pairing
- Four Control Groups
- Individual A-Net Slot activation buttons per channel
- Save and recall 16 preset configurations
- Virtual Data Cable™ connectivity for GPIO, MIDI, and RS-232
- Two A-Net ports
- EtherCon® RJ45 network connectors
- Backup DC power connector

RCI Remote Control Interface Features:

- Any number of RCI modules can be installed in a Pro64 network
- Four Control Groups
- Headphone monitor with level control
- Rear-panel XLR line-level output for monitoring selected mic preamp channel
- Pad switch for XLR line-level output
- Backup DC power connector

MCS Mic Control Surface Features:

- Full real-time control of the selected channel's gain, phase, mute, pad, +48V phantom power, and low cut filter
- Real-time metering of 64-channel network stream
- Intuitive user interface with numeric keypad
- High resolution metering of selected channel
- Access to all Pro64 network audio resources
- Switchable peak hold
- Save and recall of 6416m presets
- Monitor up to 64 active Pro64 network channels simultaneously
- Simple Cat-5e connection to RCI
- Can be used simultaneously with m-control

The EtherCon Connector

Pro64 Series products feature locking connectors for all network I/O. The Neutrik® EtherCon connector is a dual RJ45-type connector that can receive a standard Category 5e cable or a cable fitted with the special locking EtherCon connector.

When using a standard Cat-5e cable, plug the cable into the center of the EtherCon jack; release the cable by pressing on the small plastic tab built into the cable connector.

The locking EtherCon connector is similar to an XLR plug, the kind commonly used on microphone cables. Insert an EtherCon-equipped cable into the jack until it clicks and locks in place. To remove the cable, press on the metal release tab at the top of the panel-mounted EtherCon jack and pull the connector outward.

AC Power

Always plug the unit into a properly grounded (earthed) outlet. Always use the AC line cord that was shipped with the unit. Grasp the power cable by the connector and never by the cord itself when connecting and disconnecting it from the power source.

Do not expose the Pro64 device to moisture, rain, or excessively damp environments.

AC Line Conditioning

Aviom products are digital devices and as such are sensitive to sudden spikes and drops in the AC line voltage. Changes in the line voltage from lightning, power outages, etc., can sometimes damage electronic equipment.

To minimize the chance of damage to your equipment from sudden changes in the AC line voltage, you may want to plug your equipment into a power source that has surge and spike protection. Power outlet strips are available with built-in surge protection circuits that may help protect your equipment.

Other options for protection of your equipment include the use of an AC line conditioner or a battery backup system (sometimes referred to as an *uninterruptible power supply*, or UPS).

Rack Mounting

Pro64 products are designed to be mounted in a 19-inch equipment rack. The rack ears on each side of the device are designed to support the weight of the product without additional hardware. Each rack ear contains holes for two screws per side. Always support the unit with all four screws to avoid damage to the unit.

To rack mount the Pro64 product, position it in the equipment rack at the desired location. Use standard rack-mounting screws (10-32 size) to attach the unit to your rack hardware. Tighten all four screws firmly, but avoid overtightening.

Aviom suggests the use of non-metallic washers between the rack-mounting screws and the device's finished surface to avoid marring the finish on your Aviom products.

Transporting the 6416m in a Rack

The 6416m Mic Input Module has attachment points for rear support hardware built into the product's sides. If the 6416m is to be rack mounted and transported frequently, be sure to support the rear of the unit with appropriate mounting hardware that matches the size of the rack used to avoid damage to the product.

Ventilation

The 6416m is convection cooled and does not require a built-in fan. Always allow adequate ventilation for devices mounted in equipment racks. Avoid placing your Pro64 product directly above or below other rack-mounted devices that produce high levels of heat, such as power amplifiers.

Do not block the side and back vented openings in the product's case. The openings in the top may be blocked as long as the temperature immediately around the unit remains below 50°C. Although use in ambient temperatures exceeding 50°C isn't recommended, leaving an open rack space above the unit will provide additional margin in extreme temperature conditions.

Cleaning

Before cleaning a Pro64 product, turn off the power switch and unplug the unit from the AC power source.

To clean the surface of the Pro64 product use a clean, soft lint-free cloth that has been slightly moistened with water only. For tougher dirt, use a cloth slightly dampened with water or with a mild detergent. Always be sure to dry the surface of the unit before proceeding with use.

When cleaning your Aviom products, never spray cleaners directly onto the product surfaces. Instead, spray a small amount of the cleaning solution onto a clean cloth first. Then use the dampened cloth to clean the product.

Never use solvents or abrasive cleaners on the finished surfaces of your Aviom products.

About A-Net

Aviom's A-Net® is the only networking technology conceived, designed, and optimized for managing and distributing audio using ordinary Cat-5e cables (or fiber by adding the MH10f Merger Hub). As implemented in the Pro64® Series products, A-Net can transmit up to 128 channels of uncompressed 24-bit audio with the reliability and fidelity of analog, and the power and flexibility of a true digital network.

Pro64 A-Net allows variable sample rates in three ranges, from 44.1kHz± to 192kHz±, with ultra-low latency, jitter, and wander. Pro64 devices can be connected in any combination of serial (daisy-chain) or parallel (star) topologies. Cable runs between Pro64 devices can be up to 400 feet (120 meters) on Cat-5e¹, and miles on fiber optics (with Aviom fiber-capable equipment).

Because A-Net is designed specifically for audio, the technological limitations of Ethernet and Ethernet-based products are removed, while audio performance and system flexibility are increased. A-Net incorporates Aviom's unique patented and patent-pending algorithms for controlling clock jitter and wander, as well as system-wide latency—regardless of an installation's size, design, or clocking setup. A-Net offers significant advantages in fidelity, performance, and flexibility over Ethernet-based products.

A-Net uses the “physical” layer of Ethernet, but it eliminates all the protocol elements that are designed for computers and IT-style networking. In audio applications, these other layers reduce efficiency, impose system restrictions, and introduce latency and timing instability. By eliminating Ethernet data structures, A-Net creates a superior network with enhanced audio performance. With A-Net and the Pro64 Series, Aviom continues to break new ground in the design and development of innovative digital audio networking technologies and solutions.

Pro64 Series Supported Sample Rates		
Sample Rate	Minimum	Maximum
1x 44.1/48kHz	39.7kHz	52kHz
2x 88.2/96kHz	79.4kHz	104kHz
4x 176.4/192kHz	158.8kHz	208kHz

Clocking

The Pro64 network offers the most flexible clocking and synchronization options in the industry. Pro64 devices support three ranges of variable sample

1 Cat-5e, Cat-6, or better, Unshielded Twisted Pair (UTP) cable

rates, from 44.1/48kHz± to 192kHz±. Because no sample rate converters are used, audio transmission is kept fast and clean, eliminating the audio artifacts and signal degradation inherent to sample rate conversion—even when syncing to an external clock source.

Any Pro64 I/O module can be designated the Clock Master for the network, generating and distributing its internal clock. Digital I/O modules are capable of syncing to and distributing an external clock from a Word Clock or AES3 source to the network.

Control Data

The Pro64 Series has built-in, dedicated bandwidth for 14 channels of non-audio control data through the use of Aviom's innovative Virtual Data Cables™. These data streams are always available to carry MIDI, RS-232, RS-422, or GPIO (General Purpose I/O), and they never compete with the audio channels for network resources, regardless of the system configuration. (Not all VDC™ data types are supported on every Pro64 module.)

Because VDC inputs are simply incorporated into the A-Net stream, these control signals can be transmitted over very long cable runs and even across an entire Pro64 network, significantly expanding the applications possible with MIDI, RS-232/422, and GPIO. And as with audio signals, VDC control data can be input anywhere and output anywhere else in the network.

A-Net Ports

Pro64 I/O modules have dual A-Net ports, labeled A and B. Both ports carry a bidirectional A-Net stream at all times. (That is, both ports are always transmitting and receiving A-Net data.) Pro64 networks can be configured in one of two operational modes, Auto Mode or Manual Mode, depending on the requirements of a particular system.

In Auto Mode, there are no connection rules; connect a Cat-5e cable to either the A or B port and the system does the rest. Auto Mode provides a true audio network with 64 available "Slots" for transporting audio (at 44.1/48kHz). Every audio Slot is available everywhere in the system, with no upstream/downstream restrictions.

In Manual Mode, the Pro64 network becomes a 64x64 system (at 48kHz), similar to a traditional stage-to-FOH snake. At every point in the Manual Mode network, two 64-channel streams are available on the cable and in each module. The configuration of the cables and ports has an impact on the makeup of the network and the distribution of audio signals. The user can direct A-Net data from an input module to a specific port (A, B, or both). Output modules can be configured to output audio signals received from a specific A-Net port (A or B).

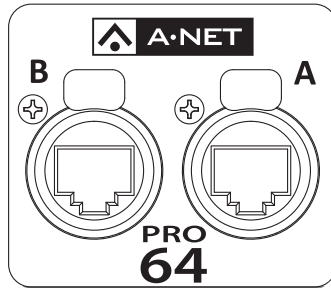

Support For Pro16 Series Products

Pro64 Series products can be combined with Pro16™ Series output products such as the Pro16 Monitor Mixing System by adding the Pro64 ASI A-Net Systems Interface. This 1U module converts Pro64 data to Pro16 data, providing up to four streams of 16-channel data (depending on the Pro64 sample rate) that can be used with A-16II and A-16R Personal Mixers, A-Net Distributors, and AN-16/o Output Modules.

The ASI is not compatible with the A-Net output of Pro16 input modules such as the AN-16/i, AN-16/i-M, the Y1 console interface card (for Yamaha® digital products), and A-Net console cards built by third-party manufacturers for their digital console products.

Firmware Notice

All Pro64 devices in a network should be updated to use the most recent firmware version to ensure trouble-free operation.

As new Pro64 modules are released, older Pro64 products need to be updated so that they recognize the features and functions of the newer modules—something that is especially important if one of the older devices will be used as the network's Control Master. (If for some reason you cannot update the firmware on older Pro64 devices before using them, set the newest module to be the network Control Master.)

Pro64 Update Tool is a free Windows software application for updating the operating firmware in Pro64 Series products.

The Pro64 Update Tool requires a direct RS-232 (serial) connection between the computer and the Control Master device on the Pro64 network. Normally this is accomplished by connecting a null modem DB9 cable between the RS-232 jack on the computer and the Pro64 device. Complete information on using RS-232 (and USB-to-RS-232 adapters) is available on the Aviom website. Updates take just a few minutes per module.

Pro64 Update Tool is designed to run on a PC under Microsoft® Windows® XP. It has also been tested and found to be compatible with Microsoft Windows Vista®. Mac users can run Pro64 Update Tool using Windows XP running under Apple's Boot Camp program on Intel-based Macs.

Get the Pro64 Update Tool and firmware update files from the Aviom website: <http://www.aviom.com>

Pro64 Interface Conventions

Many Pro64 Series products have similar user interface components, including buttons, LEDs, and switches. When describing the features and functions of Pro64 Series products, the following conventions will be used.

Cat-5e

All Cat-5e connections between A-Net devices should use Unshielded Twisted Pair (UTP) cable. The cable can be of the stranded or solid type; solid wire performs better over long distances, while stranded wire is more flexible and easier to manipulate and therefore easier to work with in a performance situation where short cables are required.

Cables designated as Cat-5e in Pro64 documentation can be interchanged with any Cat-6 (or better) cable. Cables will be referred to simply as “Cat-5e.”

Connectors on Cat-5e cables can be of the standard RJ45 variety or locking Neutrik EtherCon type.

Button Presses

When referring to specific front-panel labels, LEDs, and buttons, or when describing a Pro64 function that requires the press of a button on the front panel of a device, a special typeface will be used. For example, “Press the **ENTER** button to confirm the sample rate change.”

Buttons that work in combination, giving the user a choice when performing an operation, will be referred to as one unit. For example, “Changing the sample rate requires the user to confirm the change using the Enter/Cancel buttons.”

Changing Values

When editing values on the front panel of a Pro64 device, some operations will require the use of the inc/dec buttons (short for increment/decrement) . These buttons scroll up and down through a list of available values. Holding the button down does not accelerate scrolling. The front panel of a Pro64 module is marked only with indicator arrows.

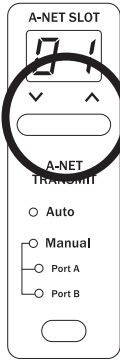

The buttons with up/down indicator arrows are used for the inc/dec functions.

Buttons of this type will be referred to as “inc/dec” buttons.

Selecting Values

Some settings, including Sample Rate, Network Mode (Auto or Manual), and Virtual Data Cable type, require the user to select from a range of values. The button that controls the selection of a value is referred to generically as the “selection button” for that function. For example, “Use the Sample Rate selection button to scroll through the available rates.”

Pressing a selection button repeatedly will scroll through the available settings and will wrap around when the end of the list is reached.

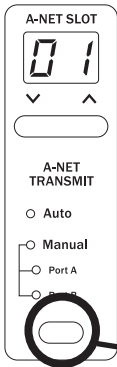

Pressing the selection button will cycle through the available values.

DIP Switches

Illustrations of Pro64 DIP switch components indicate the switch handles in black, as seen below.



Pro64 User Interface

This section outlines some basic concepts of operation for Pro64 products. Pro64 I/O devices have some common user interface elements that make setting up an audio network easy to understand.

Common elements include:

- A-Net Slot selection
- Network Mode (Auto/Manual)
- Sample Rate display
- Managed button
- Edit Lock button
- Enter button
- Cancel button
- Virtual Data Cable (VDC) configuration

In addition, each I/O module has the ability to be set as the Control Master and/or Clock Master (depending on the actual makeup of the analog/digital modules in the audio network). Only one device can have control of these functions at a time in a properly configured Pro64 network.

Basic Actions

Most system-level operations in the Pro64 user interface require the use of the Enter button to confirm an action. For example, assigning a Virtual Data Cable port to a VDC Slot or choosing a new sample rate (on the Clock Master device only) will require the user to press the **ENTER** button to confirm the request. If no press of the Enter button is detected within a predetermined time frame, the system will automatically cancel the request and return the device (or entire network) to the previous state.

Operations that do not require the use of the Enter/Cancel buttons include:

- Stereo channel link (input modules)
- Channel activation (input modules)
- Channel on/off (output modules)
- Gain settings (input modules)
- Output level settings (output modules)

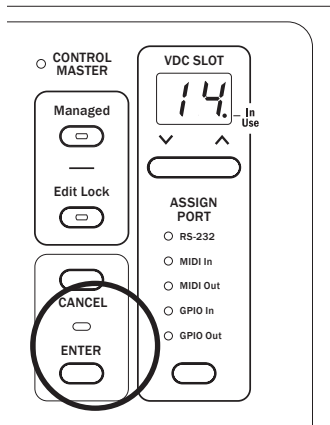

The LED between the Enter and Cancel buttons flashes when a button press is required to continue.

Any operation that requires the use of the Enter/Cancel buttons will flash the LED that is located between the two buttons to indicate that a button press is required to complete the action. To confirm an operation, press **ENTER**. To exit an operation without completing it, press the **CANCEL** button.

A-Net Slot

Pro64 I/O devices come in a variety of configurations. To allow a large number of hardware audio input devices to be available to the Pro64 audio network, Aviom has implemented the concept of the A-Net Slot to simplify the configuration of potentially complex audio networks.

A Pro64 audio network will always have a finite number of A-Net Slots available that can be addressed by an unlimited number of hardware channels. The actual number of available Slots is determined by the current sample rate.

Slots versus Channels

You might be wondering why Aviom chose to refer to the audio I/O resources in the Pro64 Series products as “Slots.” Why not just call them “channels”?

We did this to avoid confusion between references to *hardware* audio resources and *network* audio resources. The word “channel” is ambiguous and may cause confusion when configuring an audio network. “Channel” appears in many contexts, including audio mixing consoles, mic preamps, DSP processors, and DAW software.

We use the word “channel” when referring to the *physical* audio inputs—

analog or digital—on a piece of hardware (such as the 16 mic/line XLR input jacks on the 6416m Mic Input Module). Each of these audio inputs can be made active and added to the network individually, and it is only when *activated* that they use any network resources (the A-Net Slots). To enable this powerful feature, Pro64 products separate the hardware resources from the available network resources with a button that allows each hardware input channel it to be added to the network as needed.

It is these activated hardware resources that are being referred to as “Slots.” Pro64 audio networks can potentially have a greater number of audio channels and hardware I/O devices connected than the network can make use of at one time. This provides flexibility without requiring constant re-patching or complicated computer programming.

Keep in mind that a Pro64 A-Net network can only manage a specific number of Slots at a time, and this number varies with the sample rate being used. The maximums are 64 Slots in Auto Mode at the 48kHz sampling rate and 64x64 Slots in Manual Mode at 48kHz.

In summary, think of “channels” as hardware resources that can be added to the network as needed and “Slots” as locations within the digital audio network pipeline that A-Net uses to move data throughout the network.

Slots and Sample Rate

The current system-wide sample rate will determine the number of A-Net Slots that are available. Auto Mode and Manual Mode have the same number of Slots at each sample rate; only the direction of the data is different.

Sample Rate	A-Net Slots
44.1kHz	64
48kHz	64
88.2kHz	32
96kHz	32
176.4kHz	16
192kHz	16

Even though the network sample rate may change the available number of A-Net Slots, the capacity of a hardware device does not change. That is, a 16-channel input module in a 192kHz network can still have all of its channels activated; all of its physical inputs can operate at 192kHz.

The current sample rate will also affect the display of available A-Net Slot ranges. Slot ranges will always have the same maximum number as seen in the sample rate chart. At 96kHz, for example, only Slots numbered 1 through 32 are available; the Slot range from 33 to 64 is inactive and unavailable at that sample rate. Slot ranges outside the maximum for the current sample rate can be selected, but attempting to activate a channel in an unavailable

range will result in an error message (the selected channel button, A-Net Slot range, and sample rate LEDs will all flash).

A-Net Slot Display

Since the capacity of the Pro64 network could be as high as 64 A-Net Slots, Pro64 hardware I/O devices need a way of routing a selected hardware channel to a selected network Slot. In the upper left corner of the front panel of a Pro64 I/O device, the A-Net Slot display and its associated inc/dec buttons are used to select a range of Slots that the hardware device will address.

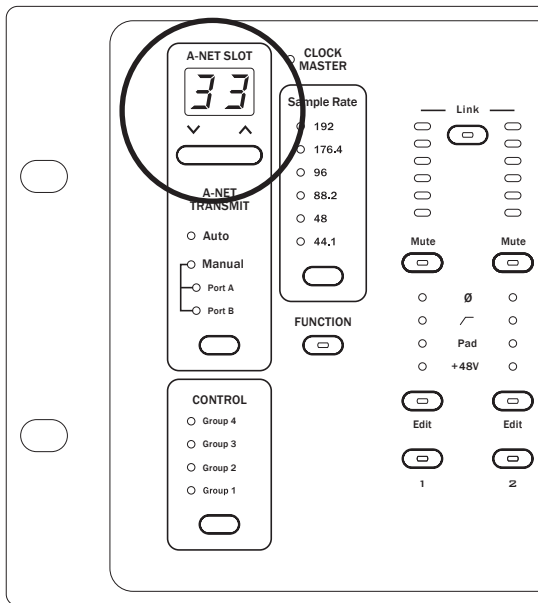

The A-Net Slot display and its inc/dec buttons are used to set the base Slot for a Pro64 I/O module.

The A-Net Slot display will show the base number that is associated with the first hardware input or output channel on an I/O device.

To select an A-Net Slot range, use the inc/dec buttons below the display. Press one of the buttons until the desired base Slot range is displayed, and then press the **ENTER** button. To return to the current selection without making a change, press the **CANCEL** button.

The following tables show examples of the channel-to-Slot correlation for 16-channel Pro64 Series modules in a network running at the 48kHz sample rate. The numbers in the Slot column will appear in the A-Net Slot display.

The numbers seen to the right of each gray base Slot number correspond to the channel buttons on the front panel of the interface.

<i>16-Channel Pro64 Module Hardware Channels</i>																
	1	2	3	4	5	6	7	8	9	10	11	12	13	14	15	16
Base Slot	A-Net Slot															
1	1	2	3	4	5	6	7	8	9	10	11	12	13	14	15	16
17	17	18	19	20	21	22	23	24	25	26	27	28	29	30	31	32
33	33	34	35	36	37	38	39	40	41	42	43	44	45	46	47	48
49	49	50	51	52	53	54	55	56	57	58	59	60	61	62	63	64

The use of Slot assignments allows for easy reconfiguration of audio networks and sharing of hardware I/O resources and data without physical re-patching.

A-Net Slot Example

The following example shows the power of the Pro64 network and the A-Net Slots concept.

The range of A-Net Slots used in the example has been limited to the group from 1 to 16 for simplicity.

This graphic represents a Pro64 product set to a base Slot range of 1.

Slot	Channel															
1	1	2	3	4	5	6	7	8	9	10	11	12	13	14	15	16

One 16-channel input module is placed in each of four rooms of a production facility, designated as Locations A, B, C, and D. One 16-channel output module is installed in the facility's Location E. All modules are set to a base Slot range of 1.

Base Slot	<i>Location A Inputs</i>															
	Channel															
1	1	2	3	4	5	6	7	8	9	10	11	12	13	14	15	16

Base Slot	<i>Location B Inputs</i>															
	Channel															
1	1	2	3	4	5	6	7	8	9	10	11	12	13	14	15	16

Base Slot	<i>Location C Inputs</i>															
	Channel															
1	1	2	3	4	5	6	7	8	9	10	11	12	13	14	15	16

Base Slot	<i>Location D Inputs</i>															
	Channel															
1	1	2	3	4	5	6	7	8	9	10	11	12	13	14	15	16

Base Slot	<i>Location E Outputs</i>															
	Channel															
1	1	2	3	4	5	6	7	8	9	10	11	12	13	14	15	16

By activating a group of channels on each of the four input modules, a total of sixteen inputs are used (indicated by reverse text). All of these inputs are available on the network at every Pro64 output module. The operator in Location E can use the sixteen inputs from Locations A, B, C, and D simultaneously.

The order in which the Pro64 devices are connected is irrelevant.

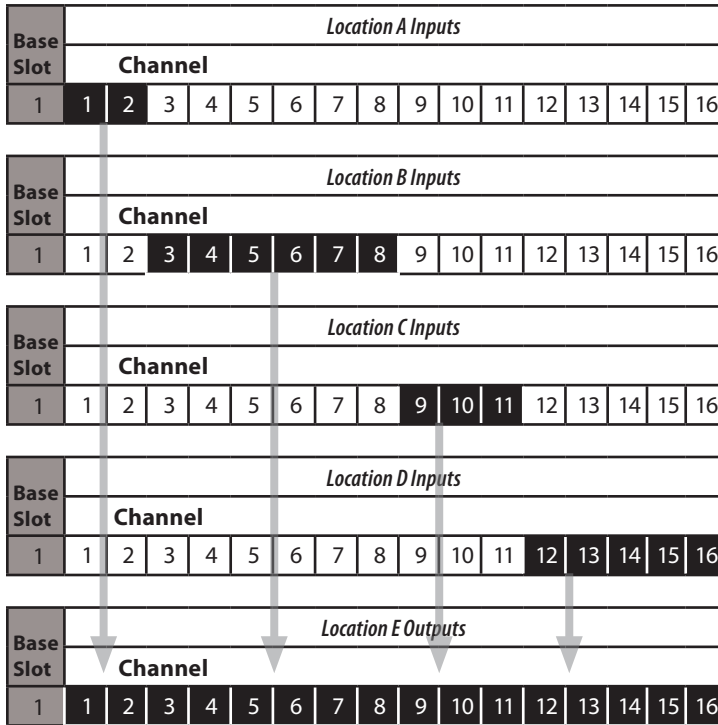

This makeup of this network can be reconfigured simply by activating a different set of channels. The input modules can be any mix of line-level, mic-level, digital, or Yamaha format console cards.

Network Modes

A Pro64 audio network can be set to operate in one of two modes, Auto or Manual. The network mode can be selected on the front panel of the device designated as the system's Control Master.

Both modes are fully bidirectional at all times, regardless of the system layout or design.

Auto Mode

Pro64's Auto Mode takes most of the work out of managing resources in an audio network. This is the "everything everywhere" mode. Channels are sent into the network and can be shared by all devices in the network, regardless of how the modules are connected and regardless of the physical location of any module. Output modules do not need to follow input modules as in a traditional analog system. In Auto Mode, both A-Net ports (A and B) function identically.

Once configured for Auto Mode, the system ensures that only one hardware input channel is activated into a given A-Net Slot. There is no limit to the number of hardware output channels that can use a given A-Net Slot. The actual number of available Slots is determined by the current sample rate. The maximum number is 64 active channels at the 44.1/48kHz sample rate.

Sample Rate	Available A-Net Slots in Auto Mode
44.1/48kHz	64
88.2/96kHz	32
176.4/192kHz	16

Manual Mode

When more than 64 channels are needed in a network, Manual Mode can be used to provide configurations of up to 64x64 channels. Two unique 64-channel streams are available at each module. In Manual Mode, the A and B A-Net port connections can be used to direct and route A-Net data.

Pro64 input modules can send their audio inputs to either or both A-Net ports, while output modules can listen to data from either port. For a traditional stage-to-FOH snake system, this allows the user to configure a system with up to 64 sends from the stage and another unique stream of up to 64 returns to the stage.

Manual Mode operation removes the restrictions of unique channel-to-Slot-range relationships found in Auto Mode. Slots can be overwritten, allowing the user to replace channels from one part of the network with new data. This means that, while no more than 128 channels can be in the network at a particular location, there is no practical limit to the total number of audio

channels in the system.

The number of available Slots in Manual Mode is dependent upon the current sample rate.

Sample Rate	Available A-Net Slots in Manual Mode
44.1/48kHz	64x64
88.2/96kHz	32x32
176.4/192kHz	16x16

Pro64 Network Concepts

Configuring a Pro64 network involves a few simple steps. This section details some of the global settings and network concepts that you should be familiar with when setting up a Pro64 system.

Control Master

In every Pro64 network, one device will always be designated as the Control Master, the device that manages all A-Net resources for the network. The Control Master can be any I/O module in the network, and can be assigned or changed by the user as needed. Only one device can be assigned as Control Master in an audio network at a time; an A-Net network cannot function without a Control Master.

The functions of the Control Master include:

- System resource and information management
- Setting network mode (Auto or Manual)
- Management of active channels in Auto Mode
- System-level command and control functions
- Keeping track of all Pro64 devices in the network (by type and quantity)
- Control of the current system-wide sample rate
- Clock Master (analog modules only)
- System lock via password on/off
- Management of Virtual Data Cable (VDC) resources
- Management of stereo link status
- Requests to enter Managed Mode

The Control Master status is identified with a red LED on the front panel of the device currently assigned as the Control Master.

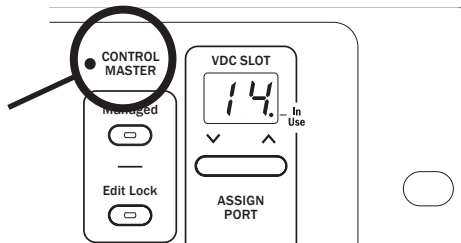

Only one device in a Pro64 network can be designated as the Control Master.

Setting Control Master Status

Setting the 6416m to be the Control Master is done using the DIP switches found on the rear panel. The Control Master switch is part of the Virtual Data Cable port section of the interface.

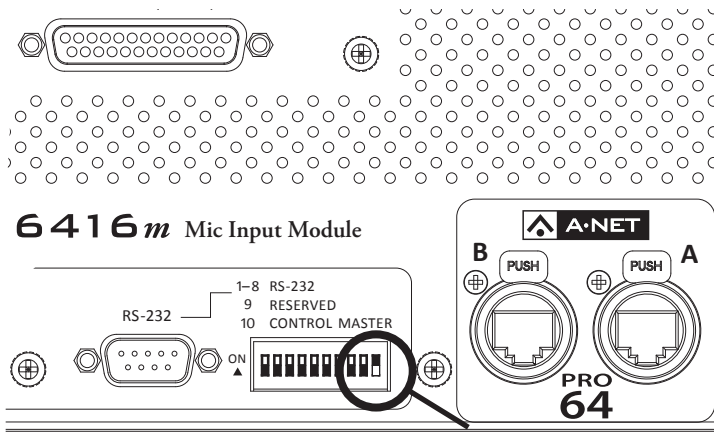

Switch 10 in the RS-232 configuration group is used to set the Control Master status. (DIP switch handles shown in black.)

In the VDC section, locate the 10-position DIP switch in the RS-232 area of the rear panel. Switch #10 will set the 6416m to be the Control Master for the Pro64 network when the switch is in the on (up) position (the *up* position is shown in black in the diagram above).

Control Master Functions

This section describes the individual functions that the designated Control Master device in a Pro64 network controls.

Enumeration

When the Control Master is powered on, its first job is to identify and count all connected A-Net modules in the network in a process called *enumeration*, similar to a PC booting up and loading its operating system. The time for this process will vary based upon the number of modules in a system.

Enumeration is an automated process performed by the command and control portion of the A-Net software. There are no user-controllable functions or settings.

During the enumeration process, all connected A-Net modules will flash their A-Net LEDs, indicating that a request to be added to the network is being made. Once granted entry by the Control Master, the individual module's blue A-Net LED will light solid to indicate that it is now receiving valid A-Net packets and is part of the network.



The blue LED in the A-Net icon is used to indicate network status.

If valid A-Net packets are not received, the module will reset and wait until a valid A-Net stream is detected.

During enumeration, any conflicts will also be resolved. For example, consider a new Auto Mode installation using eight input modules set to the same A-Net Slot range with all channels activated during a bench configuration. When all these input modules are connected and then powered up, only one of them will be allowed to have all 16 channels activated. The remaining seven modules will have their audio channels deactivated.

Adding Pro64 Modules to a Network

When a new device is added to an existing network, the new device makes a request to the Control Master for inclusion in the network. During this time, the new module's blue A-Net LED will flash. When the new module has been enumerated by the Control Master, its blue A-Net LED will then light solidly to indicate that the Control Master has granted the module access to the network. Adding a new module will interrupt network operation briefly.

Changing Settings

Most operations on Pro64 modules that make system-wide changes require the use of the Enter and Cancel buttons. For any operation that requires confirmation, the LED between the Enter and Cancel buttons will flash to indicate that the user needs to press one of these buttons in order to continue.

Press **ENTER** to complete the operation or press **CANCEL** to exit without making a change. This rule applies to all functions that can be changed by only the Control Master.

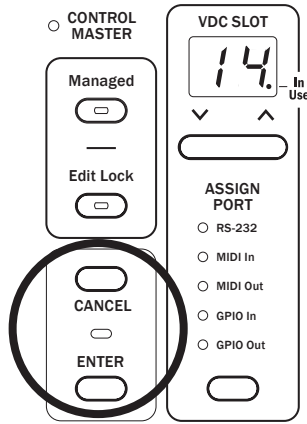

The Enter/Cancel LED will flash when the user is required to press one of these buttons in order to complete an operation.

Control Master and Clock Source

By default, the device designated as Control Master in a network consisting of all analog modules is also the device in control of the network master clock. The front-panel yellow Clock Master LED lights to indicate that a module is designated as the master clock device.

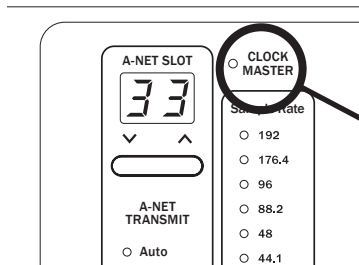

The yellow Clock Master LED lights when a Pro64 device is the Clock Master.

When an analog I/O module such as the 6416m is the Control Master, there is no other analog module that can be used as a clock source. When a digital I/O module such as the 6416dio is part of an audio network, the digital I/O device can be used as a Clock Master for the network, even if this digital device is not the network's Control Master.

External clock sources on the 6416dio Digital I/O Module can include:

- Word Clock - via the dedicated BNC Word Clock jack
- AES3 (AES/EBU) - from AES3 digital stream 1/2

When the 6416m is set to be the Clock Master, only its internal clock source is available; there is no external clock input on analog Pro64 modules.

Clock Errors

If a clock error occurs, the Clock Master LED will blink indicating that an error has occurred. Common causes for a clock error include:

- Attempting to change the sample rate on an analog device other than the Clock Master in an all-analog network
- Attempting to change the clock source when the network is password protected
- Removing or changing external clock sources on a digital I/O module
- Incorrect configuration of an external clock source on a digital I/O module

Network Sample Rate

When the 6416m is the Control Master in an all-analog network, it is automatically designated as the Clock Master. It will remain the Clock Master until a different analog module is made the Control Master or until a digital module such as the 6416dio Digital I/O Module is added to the network and is set to be the Clock Master.

The Clock Master LED will light automatically on the Control Master when that module is powered on. (Only a digital I/O module can be the source of the network's master clock without being the Control Master.)

The system's internal master clock is derived from the sample rate currently in use. The sample rate also affects the total number of available A-Net Slots available for use in the network.

The Sample Rate section of the 6416m front-panel interface includes a group of LED indicators for displaying the current network sample rate. One LED will be lit at all times.

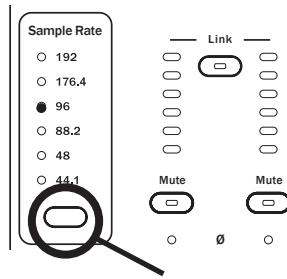

Press the selection button to cycle through the available sample rates.

The current sample rate for the network will be displayed on all I/O modules in the network. Only one sample rate can be used at a time.

Changing the Sample Rate

To set or change a network-wide sample rate from the Clock Master, use the button below the Sample Rate LEDs to select a new rate. Pressing the Sample Rate selector button will cycle through all available sample rates, flashing the value for the new rate. At the same time, the LED between the Enter and Cancel buttons will flash, indicating that pressing one of these buttons is required to confirm and complete (or cancel) the operation.

Changing the sample rate will affect the number of available A-Net Slots when the sample rate changes from the 1x range (44.1/48kHz), to the 2x range (88.2/96kHz), to the 4x range (176.4/192kHz) or vice versa.

Note that Yamaha devices are not compatible with sample rates above 96kHz when a 6416Y2 card is included in a Pro64 network.

Auto/Manual Mode Selection

The Control Master can be used to set the current network mode for the system to Auto or Manual. As with the system-wide sample rate, the network mode is also a global setting.

The network mode selection controls are in the same part of the user interface as the A-Net Slot selection.

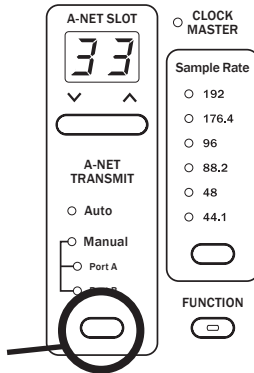

The selection button in the A-Net Transmit section of the interface is used to choose Manual Mode options.

Changing the Network Mode

The button beneath the Auto/Manual Mode LEDs is used to select the network mode and to set the transmit port in Manual Mode. Pressing the selection button will cycle through the available settings and will flash both the mode LED and the Enter/Cancel LED. To confirm and change the network mode, press the **ENTER** button. The Control Master will update the display on all modules in the network to reflect the change. Press the **CANCEL** button to exit the mode change and return to the current state.

Managed Mode

Managed Mode requires the use of a computer with the Pro64 network for tasks such as firmware updates, system monitoring, control, and editing. The Control Master is the only module that can allow the network to enter Managed Mode.

Entering Managed Mode requires the user to press the **ENTER** button after pressing the **MANAGED** button on the Control Master. Once the network enters Managed Mode, all modules will light their Managed LEDs.

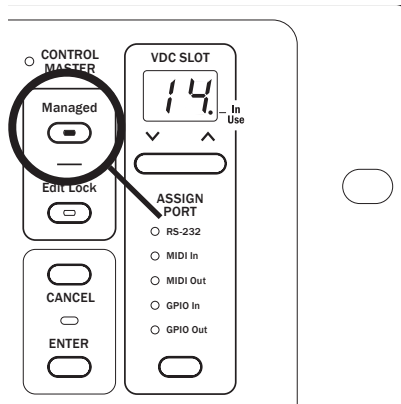

Managed Mode allows the network to be controlled from a computer and can only be entered from the Control Master.

To manage a Pro64 network with a PC, the PC needs to be connected to the Control Master using a DB9 null modem cable connected to the RS-232 port. The RS-232 baud rate DIP switches must also be set to the same rate as the PC application.

Exiting Managed Mode is also done from the Control Master. Pressing the lit **MANAGED** button followed by the **ENTER** button will return the network to local control. Attempting to enter or exit Managed Mode from any module other than the Control Master will cause the Managed button LED to blink to indicate the error.

Password Protection

All Pro64 devices ship with a default password. However, a Pro64 network can be password protected from the Control Master only. Once protected, the front-panel interface on all modules is locked, preventing changes to A-Net Slots, sample rate, clock source, channel activation, stereo links, and Virtual Data Cable assignments. Hardware switches, such as gain settings on input and output modules, and rear-panel DIP switches are in the analog domain and are not affected.

Password protection remains in force even when a system is power cycled.

When a network is password protected, the front panel interface can be used to get information on channel Slot assignments and VDC routings. Pressing a channel button will display its Slot assignment in the A-Net Slot display. Pressing the VDC inc/dec buttons will cycle through the fourteen VDC Slots, displaying any port assignments on the current module, as well as the In Use LED for all active VDC Slots in the network. This query behavior is similar to

the behavior of an individual module when it is edit locked.

See the section on Advanced Functions for a detailed description of the password protection commands.

6416m Front Panel Components

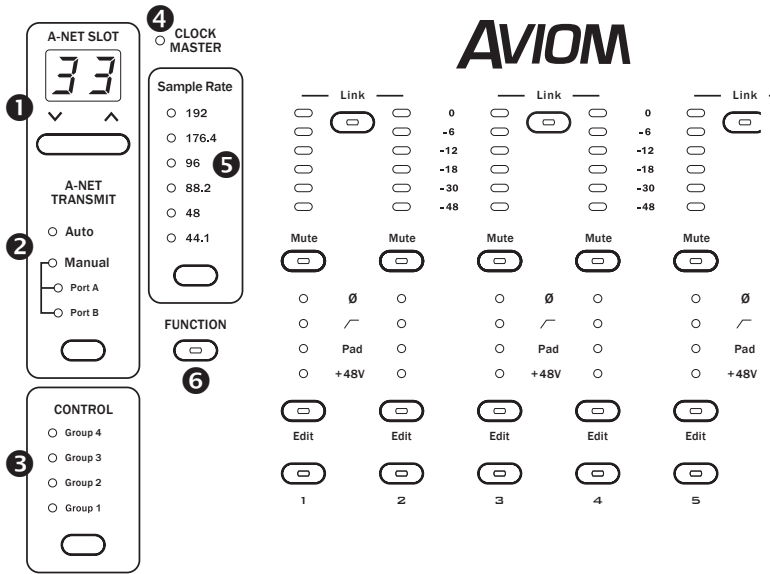

1. A-Net Slot Configuration
2. A-Net Transmit; Auto/Manual Mode Selection
3. Control Group
4. Clock Master
5. Sample Rate
6. Function Button

6416m Front Panel Components

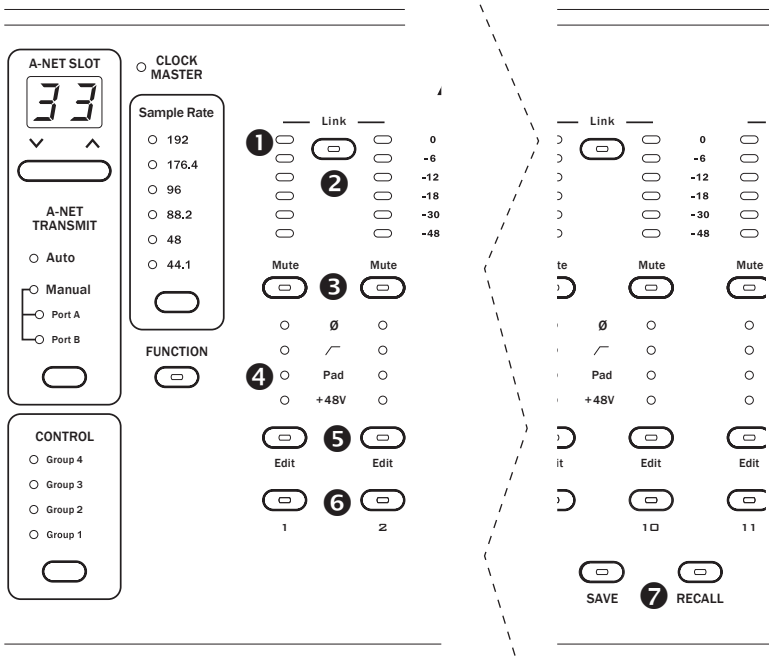

1. Level Meter LEDs
2. Stereo Link Button
3. Mute Button
4. Phase, Low Cut, Pad, and +48V LEDs
5. Edit Button
6. Channel Activation Button
7. Mic Pre Preset Save/Recall

6416m Front Panel Components

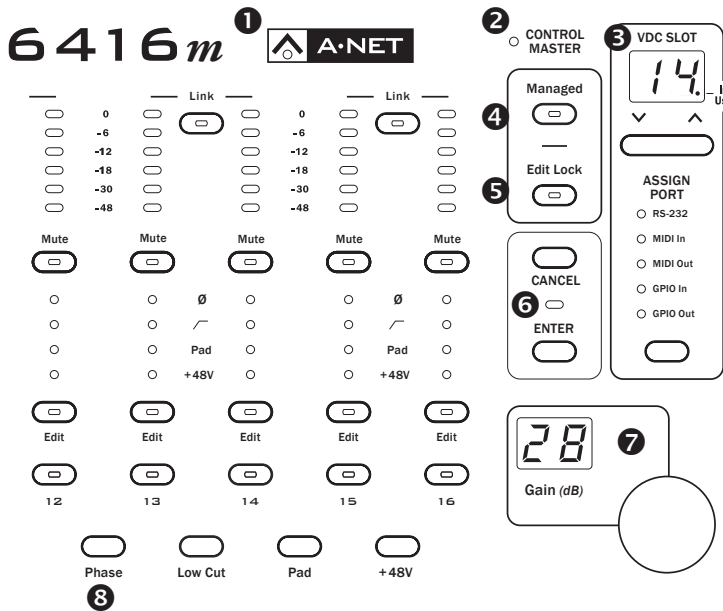

1. A-Net LED
2. Control Master LED
3. VDC Slot and Port Configuration
4. Managed Mode Button
5. Edit Lock Button
6. Enter/Cancel Buttons and LED
7. Gain Knob and Readout
8. Phase, Low Cut, Pad, and +48V Buttons

6416m Rear Panel Components

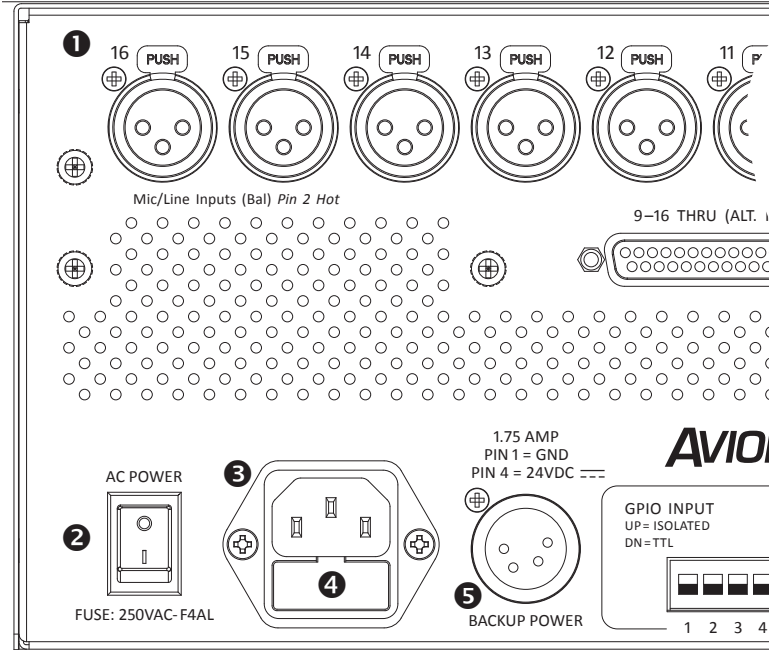

1. XLR mic/line inputs
2. Power On/Off Switch
3. IEC Power Inlet
4. Fuse Holder
5. Backup DC Power Inlet
6. Control Master DIP Switch (#10)
7. A-Net Ports, EtherCon Jacks

Input Module

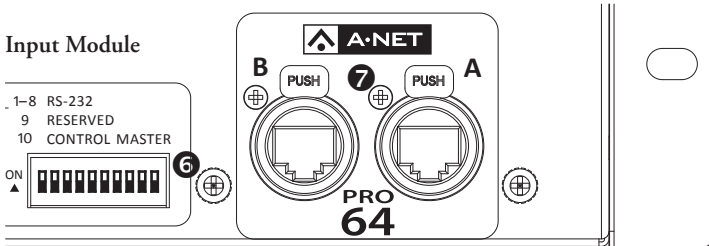

6416m Rear Panel Components

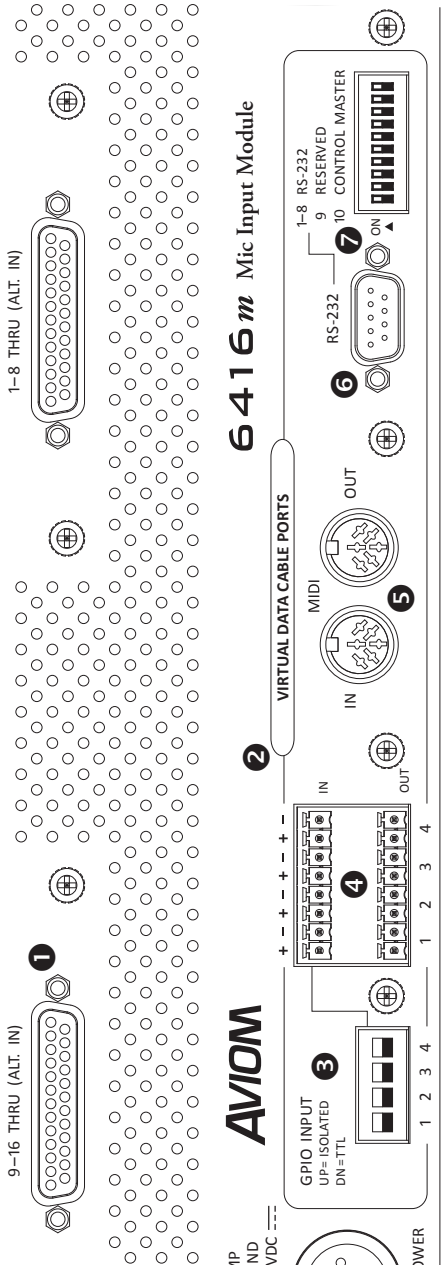

1. DB25 Audio Thru/Alternate In, x2
2. Virtual Data Cable Ports
3. GPIO Configuration DIP Switches
4. GPIO Terminal Blocks
5. MIDI In, MIDI Out
6. RS-232 Port
7. RS-232 Configuration DIP Switches (1-8)

6416m Network Settings

There are a few basic concepts that need to be understood when setting up a Pro64 network. Some of the functions described below do not need to be set on every Pro64 device in the network as they only need to be set up on the network's Control Master, the module in charge of network resource management.

Control Master

One Pro64 module in every network must be designated as the Control Master. To set the 6416m as the Control Master, DIP switch #10 in the Virtual Data Cables™ section is used. Set this DIP switch to the up position with the power off to avoid conflicts with network resources.

When the 6416m module is then powered up, the network will be enumerated and the blue A-Net LEDs on all connected Pro64 devices will be lit. On the Control Master device, its red Control Master LED will also be lit. The Control Master LED will be off on all remote/slave modules in the network.

Control Master Errors

The following rules apply to the Control Master and active Pro64 networks.

If a slave module in an active network is incorrectly switched to be a Control Master (in addition to the network's already functioning Control Master), that module's Control Master LED will light and the blue A-Net LED will go out to indicate the error. The Control Master LED will remain lit until the module is returned to slave status, at which point the A-Net LED will light to indicate that the module is now part of the network.

If a new module set to be the Control Master is added to an active running network (one that already has a valid Control Master), the new module's Control Master LED will light but its A-Net LED will not. Its audio I/O resources will remain unavailable until the module is returned to slave status. All audio on this module will be muted until the module is set to be a slave.

If the Control Master is removed from a functioning network (by being disconnected, power failure, etc.), all slave units will reset and audio will be muted. Slave units will wait for a new Control Master to be designated and at that point will begin the enumeration process. Once the network has valid A-Net communication, audio resources will become available.

A-Net Slot Range Configuration

The A-Net Slot section of the interface is used to set the range of A-Net Slots that the 6416m will use to send its active audio channels into the network. There are two components: the A-Net Slot display and the inc/dec buttons used to select a value.

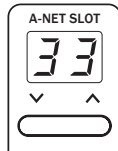

Press the up/down buttons to select an A-Net Slot range.

The A-Net Slot display will move in increments of sixteen Slots and the A-Net Slot range display will wrap as it reaches the end of the list of available values. The number shown in the display corresponds to the base Slot in a group of sixteen sequential Slots, one per channel button. The available base Slots are 1, 17, 33, and 49.

Base Slot Displayed	A-Net Slot Range
01	Slots 1-16
17	Slots 17-32
33	Slots 33-48
49	Slots 49-64

Keep in mind that the number of available Slots is determined by the current network sample rate as set by the Clock Master.

Setting the A-Net Slot Range

To set a base range for the 6416m, use the inc/dec selection buttons found below the A-Net Slot display to select the desired range. When the selection button is pressed, the new base Slot number will start to blink in the display, as will the Enter/Cancel button's LED. This indicates that confirmation is required to complete the change. Press **ENTER** to set a new base Slot or press **CANCEL** to exit without changing the base Slot and return to the previous setting. If no press of the Enter/Cancel button is detected within a brief period of time, the interface will automatically cancel the change request, returning to the previous state.

Setting a new base Slot range on the 6416m will deactivate any currently active channels.

Network Mode

The LEDs in the A-Net Transmit section show information about the current network mode, which can be set to Auto Mode or Manual Mode only at the network's Control Master. When the Pro64 network is operating in Auto Mode, the red Auto LED will be lit on all modules, and no user settings are available on a per-module basis. When using Auto Mode, it does not matter which rear-panel A-Net port (A or B) is used when connecting I/O devices to the network.

A-Net Transmit

The A-Net Transmit section of the 6416m interface is used when the network is in Manual Mode. In Manual Mode, the red Manual LED will be lit and user can direct the active channels from the 6416m to a specific rear-panel A-Net port.

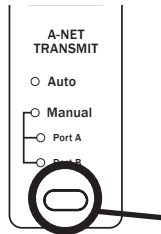

Use the selection button to choose a Transmit Port when operating the network in Manual Mode.

In Manual Mode, the user has the option of directing A-Net data to either or both A-Net ports on the rear of the 6416m Mic Input Module. Once the Control Master has set the network to operate in Manual Mode, the red Manual LED and at least one of the yellow Port LEDs will be lit on every Pro64 I/O module.

Three options are available:

- **PORT A** - the 6416m transmits data from its active channels only out of port A on the rear panel
- **PORT B** - the 6416m transmits data from active channels only out of port B
- **PORT A AND B** - (both LEDs are lit) the 6416m transmits its active channels out of both the A and B ports.

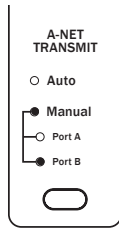

A-Net data is set to transmit out of Port B in Manual Mode in this example.

Changing the A-Net Transmit Port

This applies to Manual Mode only; no user settings are available in Auto Mode.

Use the selector button below the Auto/Manual Mode LED readout to cycle through the three options. When a new configuration is selected, the selected Port LED and the Enter/Cancel LED will blink; confirmation is required. Press **ENTER** to set a new transmit Port or press **CANCEL** to exit without making a change and return to the previous setting.

Changing the transmit Port settings in Manual Mode has no effect on the current channel activation settings. The VDCs are not affected by the network mode.

Clock Master

One device in a Pro64 network will always be set as the network's Clock Master. In a network with only analog I/O modules, the module set as the Control Master is also set to be the Clock Master by default. The Module set as the Clock Master will have its Clock Master LED lit.

When digital I/O modules are used in a network, incoming Word Clock or AES3 (also referred to as AES/EBU) digital data streams can also be used as clock sources. It is only when a digital module is part of the network that the Control Master and Clock Master can be separate devices.

Set the 6416m to be the network Control Master using DIP switch #10, found on the rear panel.

Sample Rate

Pro64 networks can operate at sample rates in three ranges without the use of sample rate converters. The current network sample rate also determines the number of available A-Net Slots.

Sample Rate	A-Net Slots Available
44.1/48kHz	64
88.2/96kHz	32
176.4/192kHz	16

In an all-analog network, the sample rate can be set at the Control Master to the following:

- 44.1kHz
- 48kHz
- 88.2kHz
- 96kHz
- 176.4kHz
- 192kHz

When an external clock is used with a Pro64 digital I/O device, the system can lock to any sample rate within the range that is shown in the table below. No sample rate converters are ever required when using an external clock. When using an external clock the Sample Rate display on the 6416m and all other Pro64 I/O modules will light the LED corresponding to the rate closest to the incoming clock rate.

Pro64 Series Supported Sample Rates		
Sample Rate	Minimum	Maximum
1x 44.1/48kHz	39.7kHz	52kHz
2x 88.2/96kHz	79.4kHz	104kHz
4x 176.4/192kHz	158.8kHz	208kHz

Changing the Sample Rate

The network sample rate can be changed only at the Clock Master. Changing the sample rate is done with the selection button found below the Sample Rate LED readout.

To choose a new sample rate when the 6416m is Clock Master, press the selection button beneath the sample rate list. Pressing the button selects the next sample rate in the list and immediately starts blinking the new rate's LED and the Enter/Cancel LED; confirmation is required. To confirm the new sample rate, press the **ENTER** button. To exit without changing the sample rate, press **CANCEL**.

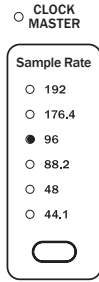

Pressing the selection button will cycle through the available sample rates. 96kHz is shown in the example.

Attempting to change the sample rate on a module that is not the Clock Master will cause the Sample Rate and Clock Master LEDs to flash to indicate the error.

Sample Rates and A-Net Slots

Changing the network sample rate has a direct effect on the availability of A-Net Slots. For example, setting the sample rate to 96kHz makes only 32 Slots available, numbers 1 through 32. Slot numbers above 32 are no longer available.

If at the 48kHz sample rate an input module such as the 6416m is set to the Slot range starting at 33 or 49 *and* has active channels, these channels will be deactivated when the sample rate changes to 96kHz. These Slot assignments no longer exist in the network.

- ✓ **Note:** When using 6416Y2 A-Net cards in Yamaha® devices as part of your Pro64 network, only sample rates up to 96kHz are valid; Yamaha devices cannot utilize the 176.4/-192kHz rate.

6416m Front Panel Features

This section describes the features and functions of all front-panel components of the 6416m Mic Input Module. Many of the network-wide settings are common to other Pro64 modules and will be familiar to users of other Pro64 devices.

A-Net Slot Configuration

Each I/O module in a Pro64 network can be set to operate within a specific part of the network, referred to as its Slot range. The actual number of Slots available in a network is determined by the current sample rate; at 48kHz, there are 64 Slots available, for example.

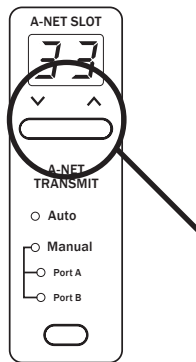

The inc/dec buttons below the Slot readout are used to scroll through the available Slot settings.

A-Net Transmit

Each input module in a Pro64 network has the capability of transmitting its input channels into the network. When using Auto Mode, the network manages the access of these channels to the available Slots. Auto Mode is indicated with a red LED in this section. No user options are available in this part of the interface.

In Manual Mode, the user decides how input channels will be distributed to the network. Inputs can be sent to the A port, B port, or to both ports at the same time.

Assigning the 6416m to send active inputs to the A-Net ports is done with the A-Net Transmit selection button. Press the button to cycle through the various choices.

Clock Master

Every Pro64 network will have one Clock Master. The module designated as Control Master will have its yellow Clock Master LED, found above the sample rate section, lit. In a network that uses all analog modules, setting the 6416m to be the network Control Master automatically assigns it to be the Clock Master. See page 33 for more info.

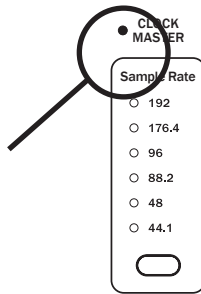

The Clock Master LED above the Sample Rate display will light when the 6416m is the network's Clock Master.

Sample Rate

The Sample Rate display will show the current network sample rate. If the 6416m is Control Master and Clock Master, changes to the current sample rate can be made from the front panel of the device.

The selection button below the Sample Rate LEDs is used to choose a sample rate (requires the use of the Enter button).

Function Button

The Function button located below the Sample Rate LEDs is used to access the Advanced Functions, described in detail later in this document (see page 97).

Control Master LED

The red Control Master LED lights to indicate that a Pro64 module has been set to be the network Control Master. Only one module can function as Control Master at a time.

VDC Slot and Port Configuration

There are 14 Virtual Data Cable Slots available to transport user control data throughout the Pro64 network without impacting audio performance. See page 94 for additional VDC setup information.

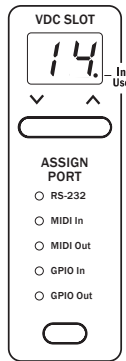

The Virtual Data Cables interface

Choose a VDC Slot with the inc/dec buttons below the Slot readout. Use the selection button below the VDC LEDs to choose an input type for the selected VDC Slot. Press **ENTER** to confirm the selection.

Enter/Cancel Buttons

The pair of buttons marked **ENTER** and **CANCEL** are used to confirm functions and mode changes or to exit a change request. The LED between the two buttons will flash whenever the user is required to press one of these buttons in order to continue with an operation or edit.

A-Net LED

The blue LED found within the A-Net logo functions as the network activity indicator. When a Pro64 module is powered up, its A-Net LED will flash while a request to enter the network is sent to and then processed by the device designated as Control Master. Once a module is enumerated and is part of the network, the blue A-Net LED will light solid. The LED will remain lit as long as valid A-Net network data is received.

The A-Net LED will flash during a firmware update when the module being updated is part of an active network. When a module is being bench configured (it is not part of an active network), the A-Net LED will be off during the firmware update. (Check the Aviom website for current firmware updates.)

Managed Button

The Managed button is used to put the network under control of a computer for firmware updates, system monitoring, etc. Managed Mode can only be engaged from the network's Control Master.

When using a PC for firmware updates, etc., a Pro64 module cannot have its RS-232/422 or MIDI port assigned to a VDC when the PC is connected. Deactivate these VDC assignments before entering Managed Mode. Connecting a PC to the Control Master requires the use of the RS-232 port for communication. The RS-232 baud rate DIP switches also need to be set to the same rate as the computer application for data transfers.

To enter Managed Mode, press the **MANAGED** button; its LED will flash. The Enter/Cancel LED will also flash. Press **ENTER** to confirm the mode change or **CANCEL** to return to the previous state.

To exit Managed Mode, press the **MANAGED** button; its LED will flash and the Enter/Cancel LED will flash. Press **ENTER** to confirm the mode change. The network returns to the previous local mode, Auto or Manual.

In Managed Mode, Virtual Data Cable and channel Active buttons behave as if the module is edit locked; they provide information only when pressed. All other front panel edits are prohibited.

Edit Lock Button

The front panel of the 6416m can be locked to prevent accidental changes or low-level unauthorized access. Once edit locked, all front-panel functions under digital control cannot be changed. Edit Lock can be used on a module-by-module basis.

To lock a module's front panel, press the **EDIT LOCK** button. The Enter/Cancel LED will blink. Press **ENTER** to lock the unit. No other Pro64 modules in the network are affected. Press the **CANCEL** button to exit the operation without locking the device's front panel.

To unlock a Pro64 device, press the **EDIT LOCK** button again. The Enter/Cancel LED will blink. Press the **ENTER** button to unlock the unit. Press **CANCEL** to exit, leaving the unit locked.

When a Pro64 module is edit locked, all front panel operations are inactive with the following exceptions:

- The Edit Lock button, along with the Enter button, can be used to unlock the unit.
- Gain switches on I/O modules such as the 6416i are analog controls. These cannot be locked.
- Channel Active buttons can be used to get information

about the channel-to-Slot relationships.

- The VDC inc/dec buttons can be used to get info about Virtual Data Cable port assignments.

Query Functions (Get Info)

When a Pro64 module is edit locked, its front-panel channel buttons can be used to get Slot info. Pressing any channel button will display the selected channel's A-Net Slot number in the A-Net Slot display.

For example, if an input module is set to the A-Net Slot range starting at 17, pressing channel button 2 will display "18," channel button 3 will display "19," etc.

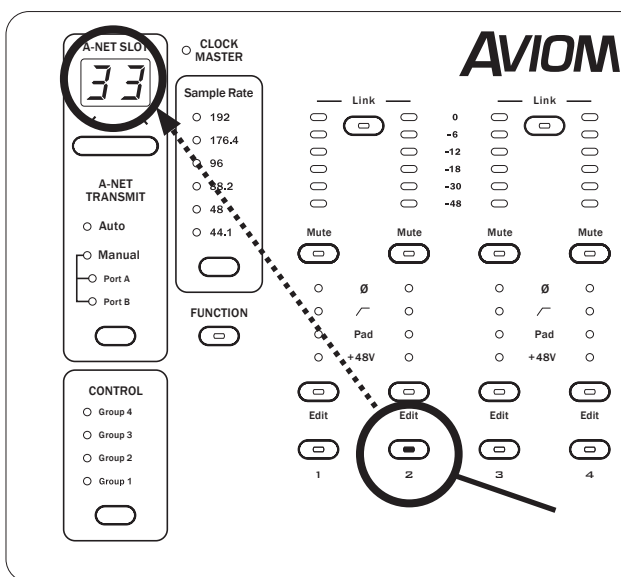

On an input module set to the A-Net Slot range starting at 17, pressing the Channel 2 button displays A-Net Slot 18 when the module is edit locked. Pressing the Channel 3 button will display "19," pressing the Channel 4 button will display "20," etc.

Channel activation status is not affected by the use of the query function. It is used for information only.

To Exit the query function, press **EDIT LOCK** followed by **ENTER** to return to normal operation.

Control Group

The Control Group functions are unique to the 6416m Mic Input Module and the RCI Remote Control Interface.

Control Groups are useful when you want to have multiple 6416m modules in a network separated into specific zones or when more than one operator will be editing channel strip parameters remotely.

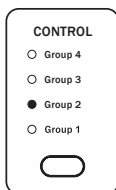

Press the select button to choose a Group.

The RCI Remote Control Interface and MCS Mic Control Surface are required to make use of the Control Group functionality. The setting of the Control Group section of the 6416m interface has no effect when the RCI/MCS combination is not part of the Pro64 network.

Pressing the Control Group selection button will cycle through the five settings: Groups 1-4 and off (no LED lit). The 6416m and RCI must be set to the same Control Group to allow remote control commands to be recognized. Setting the Control Group to the off position makes a 6416m module unavailable for editing remotely from the RCI/MCS. Front panel edits are not disabled.

The Control Group setting is not saved as part of a mic preamp Preset.

6416m Channel Strip Functions

The features of the 6416m mic preamp channels are described in detail in this section. Most of these features can also be remote controlled by adding the optional RCI Remote Control Interface and MCS Mic Control Surface.

All operations described below apply to the currently selected mic pre channel.

Channel Activation Button

Each of the sixteen mic/line input channels on the 6416m can be made active on the network individually using the lighted Active button found above the channel number. Activating a channel assigns it to an A-Net Slot, making it part of the network and available to any output module or console interface card in the Pro64 network.

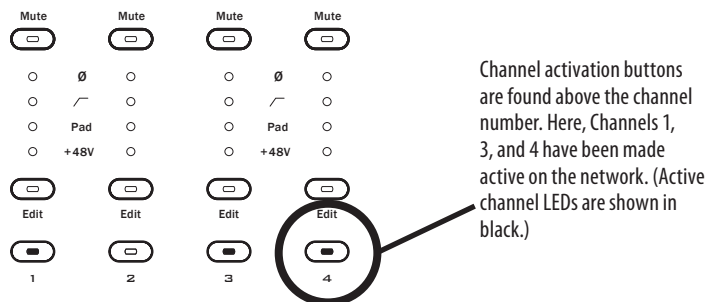

In Auto Mode, each A-Net Slot is unique. The Control Master manages the availability of A-Net Slots and will grant or deny a channel activation request from an input module based on the current makeup of the network, the sample rate, and the Slots already in use.

To activate a 6416m input channel within a given A-Net Slot range, press its numbered **ACTIVE** button. (Note that the word “Active” does not appear on the front panel user interface.) If the Slot is available, the Control Master will enable the Slot and the channel’s green LED will light. If the Slot is not available, the LED will flash briefly, indicating that the requested Slot is in use elsewhere in the network.

In Manual Mode, a channel can be activated at any time. Depending on how the network is set up and configured, activating a channel can replace a same-numbered Slot that was added to the network elsewhere.

Channel Activation Rules

It is not necessary to press the **ENTER** button to activate or deactivate a channel.

Each Pro64 module remembers a unique set of active channels for Auto and Manual Modes. For example, an input module could have channels 1-8 active for an Auto Mode application and channels 5-6 and 12-16 active for a Manual Mode application. Changing network modes will restore the active channel status for each connected module.

- ✓ **NOTE:** The active state for the channels on a 6416m is not saved as part of a mic pre Preset.

Changing the A-Net Slot range will clear the currently active channels on an input module automatically to protect against channel/Slot conflicts or unintentional overwriting in Manual Mode.

Level Meter LEDs

Each input channel on the 6416m Mic Input Module has its own set of six level LEDs—green, yellow, and red. Green LEDs are used for all levels up to -6dB. The yellow LED lights when the signal level reaches -6dB. Clipping is indicated with the red LED, which lights when the level reaches 0dB. High resolution metering with finer resolution and more LEDs is available when using the MCS.

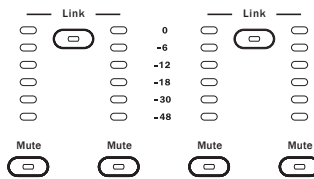

Each input channel has its own LED level meter.

The level meter LEDs will always show the level of the incoming analog audio signal, even when the channel is not active on the network.

Always try to optimize input levels to assure proper gain staging throughout the network and any connected audio devices.

Stereo Link Button

Adjacent pairs of channels on the 6416m can be linked together as a stereo pair. The channels must be an odd-even pair, such as 1-2, 13-14, etc. There is one Link button for each channel pair, eight in all.

To link a pair of channels, both channels must be active on the network first; the Active button located below the Edit button must be lit on both channels. Once the two channels are active, pressing the **LINK** button will link the two channels immediately; no confirmation is required.

Attempting to link channels that do not meet the requirements above will cause the Link button and one or more channel button LEDs to flash to indicate the error.

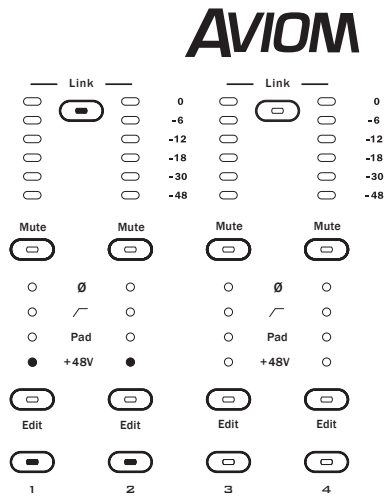

To link a pair of channels, both channels must be active first.

Linked channels will be displayed on all Pro64 output modules. Link information can be used by Pro16 output devices such as the A-16II and A-16R Personal Mixers. Add the ASI A-Net Systems Interface to a Pro64 network in order to make use of Pro16 output devices.

Mute Button

Use the Mute button to silence an active mic preamp channel while leaving it active in the network. Press the **MUTE** button once to activate the mute function; press **MUTE** again to release the channel from the muted state.

Each channel's Mute state is saved as part of a mic pre Preset.

Edit Button

The Edit button gives the user access to each channel's settings for Phase, Low Cut filter, Pad, +48V phantom power, and Gain.

Only one channel can be edited at a time, even if a channel is part of a stereo pair.

To change the settings for a particular channel, press the **EDIT** button found above the channel's Active button and then use the Phase, Low Cut filter, Pad, and +48V phantom power buttons or the Gain knob as needed.

Note that some operations will also require the use of the Enter button.

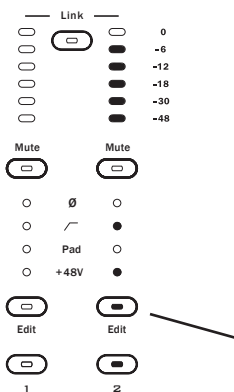

Channel 2 is active and is selected for editing.

Changes to channel settings can be made at any time, even if the channel is not active on the network.

Phase Button

Press the Phase button to invert the polarity of the input signal on the selected mic preamp channel. Use the Phase button to eliminate anomalies that occur when using two or more microphones on the same source (such as a drum kit).

To change the phase, press the **PHASE** button once; its yellow LED in the selected channel strip will light to indicate that the function is enabled. It is not necessary to press Enter. To return the audio on the selected channel to its original state, press **PHASE** again; the LED will go out.

The state of the Phase button is saved with a mic pre Preset.

Low Cut Button

The Low Cut button applies a bass rolloff filter centered at 85Hz to the selected channel. Use this to eliminate low frequency interference such as microphone handling noise, rumble, etc.

Press the **Low Cut** button once; the yellow LED in the selected channel strip will light to indicate that the function is enabled. Press **Low Cut** again to turn the filter off. It is not necessary to press Enter.

The Low Cut filter can be controlled from a Yamaha device using m-control. The filter on/off state is saved with a mic pre Preset.

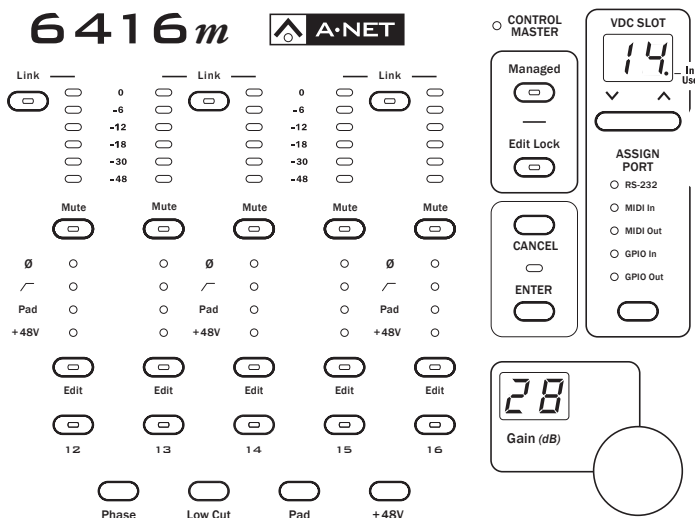

Channel strip settings include Phase, Low Cut, Pad, and +48V.

Pad Button

To lower the level of the selected channel by 24dB, press the **PAD** button. Since changes to the overall level of a channel caused by the use of the Pad can cause abrupt changes in level, the use of Enter/Cancel is required to confirm the operation.

To turn a channel's Pad on, press the **PAD** button once. The Enter and Cancel LEDs will blink. Press **ENTER**; the Pad is on. Press the **CANCEL** button to exit without turning the Pad on.

To turn the Pad off for a channel when it is enabled, press the **PAD** button. The Enter and Cancel LEDs will blink. Press **ENTER**; the Pad is turned off. Press

CANCEL to exit without turning the Pad off.

When the 24dB pad is in use, the Pad LED in the selected channel strip will be lit. When using m-control to control the 6416m from a Yamaha device, the 6416m Pad will turn on/off automatically in response to gain change messages from the Yamaha device.

Mic pre Presets save the Pad state for each channel.

+48V Phantom Power Button

Phantom power for devices such as condenser mics is available for each mic preamp channel. Turning the +48V phantom power on or off for a channel requires use of the Enter button.

Avoid potential damage to your hearing or audio equipment by muting the mic channel first if you are unsure about the use of phantom power.

To turn phantom power on, press the **+48V** button once. The Enter and Cancel LEDs will blink. Press **ENTER**; the phantom power is on. Press the **CANCEL** button to exit without turning phantom power on.

To turn a channel's phantom power off when it is enabled, press the **+48V** button. The Enter and Cancel LEDs will blink. Press **ENTER**; the phantom power is turned off. Press **CANCEL** to exit without turning the +48V phantom power off.

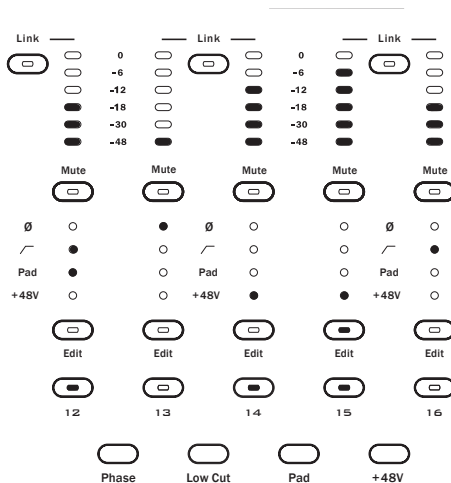

Channels 14 and 15 in this diagram are shown with the phantom power activated. Channel 15 is selected for editing.

When phantom power is enabled, the selected channel strip's +48V LED will be lit. The on/off state of the +48V phantom power is saved for every channel in each mic pre Preset.

Phantom power on/off can also be controlled from a Yamaha device when using m-control.

Channel Gain

Each input channel on the 6416m has an individual gain setting controlled by the Gain knob. Press **EDIT** to select a channel for editing and then rotate the **GAIN** knob to the desired setting. When the RCI/MCS is part of the network, gain changes can be made from the front panel or the remote controller.

Gain is set in 1dB steps and has a range of 0-55dB. Channel gain can be controlled from a Yamaha device using m-control when a 6416Y2 A-Net Interface Card is installed.

Each channel's gain setting is saved as part of a mic preamp Preset.

Gain Display

The two-digit gain display shows the level for the currently selected mic preamp channel.

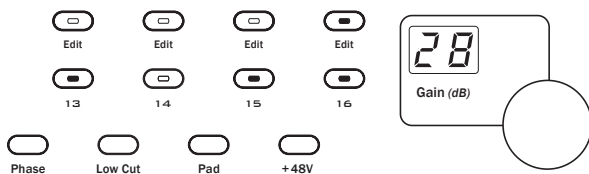

The selected channel's gain is displayed and can be edited. In this diagram channel 16 is selected for editing.

Control Group

Each 6416m mic module in a Pro64 network can be set to one of four Control Groups. This allows multiple zones of mics and preamps to be remote controlled by different users if desired by adding the optional RCI Remote Control Interface and MCS Mic Control Surface.

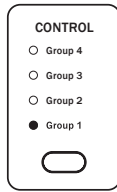

The 6416m is set to be part of Control Group 1.

A mic preamp must be set to one of the four Control Groups in order to be remote controlled using an RCI and MCS.

Use the selection button to cycle through the selections, Groups 1-4 and Off. Only active mic channels in the currently selected Control Group can be edited with an MCS connected to an RCI.

When operating a Pro64 network that contains 6416m Mic Input Modules but no RCI or MCS units, the Control Group setting has no effect.

Control Group settings are not saved as part of a Preset.

Refer to the information in the following section regarding how Presets and Control Groups interact with and without the RCI/MCS in the network.

Mic Preamp Presets

Each 6416m Mic Input Module has the ability to save 16 mic preamp Presets. Parameters that can be saved per channel include:

- Channel Mute status, on/off
- Phase on/off
- Low Cut Filter on/off
- Pad on/off
- +48V Phantom Power on/off
- Channel gain

Note that each channel's network activation status *cannot* be saved within a mic preamp Preset. The network Control Master manages active channels. Furthermore, an individual 6416m Mic Input Module cannot save information about the makeup of the Pro64 network that it was connected to at the time the preset was stored.

Save a Preset

To save the current state of the parameters described above for all channels of the 6416m from the front panel, press the **SAVE** button. The red LED in the Save button and the one between the Enter/Cancel buttons will flash. Also, the Edit button associated with the memory location last accessed for preset save or recall will flash.

Select a memory location to store the Preset in by pressing one of the 16 Edit buttons on the front panel of the 6416m. Press **ENTER** to complete the operation or press **CANCEL** to exit without storing a Preset.

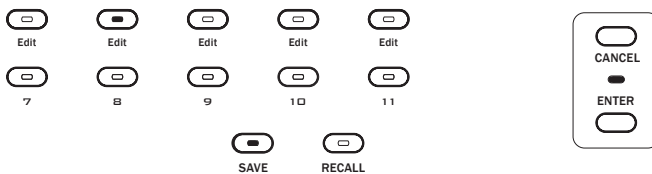

As an example, to save the Preset to location 8, press **Save**, then Edit button **#8**, followed by the **Enter** button.

Saving a Preset from the 6416m front panel saves the preset in flash memory in the local 6416m only. Saving a preset from the MCS will save the same-numbered Preset in all 6416m modules set to the same Control Group, making configuration of larger systems simple and intuitive.

- ✓ **NOTE:** To save a mic preamp Preset from the MCS, remember that the 6416m needs to be set to the same Control Group as is currently selected on the RCI that the MCS is connected to.

Recall a Preset

To recall a mic preamp Preset from the front panel of the 6416m, press the **RECALL** button. The Recall button's red LED, the Enter/Cancel LED, and the Edit button corresponding to the last Preset saved/recalled will flash. Choose the memory location that contains the desired Preset by pressing the corresponding channel Active button. Press **ENTER** to complete the operation and load the Preset, or press the **CANCEL** button to exit without recalling a Preset.

Recalling a preset will overwrite all channel parameters as described above; save a mic preamp Preset first if you want to recall the current settings at a later time. When a Preset is recalled, audio is muted briefly (a few milliseconds) while the settings are changed. This is desirable, especially when large gain changes or changes to pad and phantom power settings are included in a Preset.

Remember that when using the MCS Mic Control Surface to recall a mic preamp Preset, the 6416m needs to be set to the same Control Group as the RCI/MCS combination. Using the MCS to recall a Preset causes all 6416m preamps in the same Control Group to recall the same-numbered Preset simultaneously.

Preset Rules

When saving or recalling a mic preamp Preset from the front panel of an individual 6416m Mic Input Module, only that module is affected. For example, to save the channel strip settings for a 64-input system that includes four 6416m mic modules in a network without an RCI/MCS combination, you need to perform the save/recall operation on each module separately.

The Control Group has no bearing on the preset save/recall function when a preset is saved or recalled from the 6416m front panel.

When an RCI Remote Control Interface and MCS Mic Control Surface *are* part of a Pro64 network, the setting of the Control Group will affect the behavior of the save/recall functions. Only modules set to the same Control Group can be addressed from the RCI/MCS combination.

When a Preset is saved (or recalled) from the RCI/MCS combination, *all* 6416m modules set to the same Control Group will save or recall the same numbered Preset simultaneously.

6416m Rear Panel Features

All 6416m rear-panel features and functions are described in this section.

AC Power

Pro64 modules use switching power supplies that can operate at 100-240V and from 50-60Hz, meaning that they can be used with most of the world's AC power systems by simply changing the line cord. The 6416m is equipped with a standard grounded IEC power inlet (with fuse), which can accept the interchangeable IEC power cord.

Fuse

The fuse holder is spring-loaded and has space for two fuses, one main and one spare (optional). Press the fuse holder cover to access the fuse. When checking or replacing a fuse, always power off the Pro64 unit and remove the line cord from the AC power source.

Always replace the fuse with one with the same rating as that being changed.

Backup DC Power

For applications where a backup power source is required, the 6416m is equipped with a DC power inlet using a locking 4-pin XLR jack. A DC power supply capable of outputting 24VDC $\pm 5\%$ at 1.75 amps is required. In the locking XLR plug, connect pin 1 to ground and pin 4 to the 24VDC source. Nothing should be connected to pins 2 and 3.

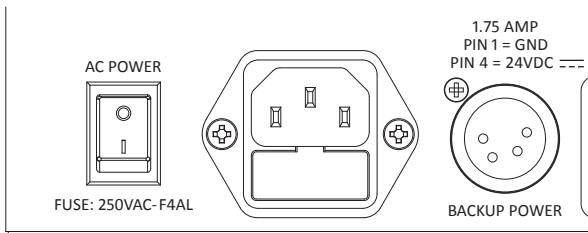

The 6416m can be powered via its internal power supply or an optional external 24 volt supply.

6416m DC Requirements

Like most electronic devices, the 6416m will draw more than its rated current

for a very brief period of time at power up. This is called in-rush current. This also happens when powering the unit through its DC Backup power input. A power supply connected to this input should be capable of sourcing 5A of in-rush current for 5ms (0.1ms rise time).

Alternately, some power supply manufacturers indicate in-rush current sourcing capability by specifying a maximum capacitive load. In the 6416m's case, a supply should be chosen that can handle a 2500µf load.

However, many power supplies have no specification concerning transient current capability. In this case, a 100 watt (24V @ 4A) or greater, power supply should be utilized. Although a 65 watt power supply is adequate to power the 6416m, a 100 watt or greater power supply should be capable of meeting the 6416m's in-rush current requirements.

Both internal AC and external DC power sources can be connected simultaneously. The AC power switch controls the AC power source only.

A-Net Ports

Two EtherCon jacks are provided for A-Net connections, labeled A and B. Connections can use standard RJ45-style cables or cables outfitted with the locking EtherCon connector. Refer to the section on network modes for additional information about using these jacks (page 17).

Balanced Mic/Line Inputs

The sixteen female XLR mic/line input jacks on the 6416m can accept balanced mic or line-level audio signals. (Using line-level sources may require the use of the channel pad to avoid clipping.)

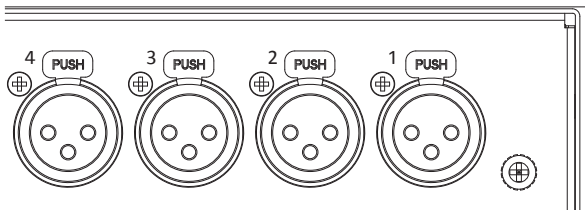

Mic/line input jacks on the 6416m rear panel

DB25 Audio Thru/Alternate In

Two female DB25 multipin connectors are provided for audio throughput on the 6416m, creating a passive split of the source signals. Channels 1-8 appear on one DB25 jack and channels 9-16 on the other. The DB25s are wired to the industry accepted Tascam® compatible analog wiring standard. Do not use DB25 cables wired for AES3 digital connections.

The DB25 Audio Thru connection allows audio signals connected to the 6416m XLR input jacks to be connected to another input device such as a mixing console or Digital Audio Workstation (DAW) interface without interrupting the signals connected to the Pro64 network.

Alternate Input

The DB25 Audio Thru connections can also be used as an optional main input path. Signals connected to the DB25 connections will be metered and can be made active on the network in the same manner as the XLR inputs.

When used in this manner, the XLR connectors would have no signals connected to them, but could be used as a passive split output if appropriately wired cables are provided.

For input connections, always use DB25 cables wired to analog audio standards; never connect multipin cables wired for AES3 digital connections.

- ✓ **NOTE:** Do not use the XLR jacks and DB25 Alternate In connections for inputs to the same set of channels on the 6416m simultaneously.

DB25 Pinout

Breakout cables for DB25-to-TRS, DB25-to-XLR connections, etc., are readily available. To create a custom cable for the Audio Thru/Alternate In function, use the following table and diagram.

Note that there are several DB25 pinouts commonly in use, including two used for AES3 digital connections. The digital pinouts are not compatible with the analog outputs of the 6416m Audio Thru connectors. Use only those cables wired for the Tascam analog audio pinout.

Channel	DB25 Pin Number		
	Hot	Cold	Ground
1	24	12	25
2	10	23	11
3	21	9	22
4	7	20	8
5	18	6	19
6	4	17	5
7	15	3	16
8	1	14	2
No Connect	13		

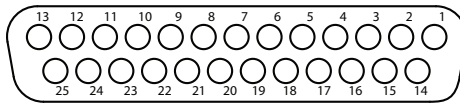

The pins on the panel-mounted DB25 jacks are numbered according to the diagram above.

The DB25 panel-mount connectors have #4-40 UNC thread.

- ✓ **Note:** Strain relief is suggested when using DB25 cable assemblies. DB25 breakout cables should always be supported when connected to a Pro64 product to reduce the risk of damaging the Pro64 product's rear panel.

Virtual Data Cables

Three types of Virtual Data Cable (VDC) ports are available on the rear panel of the 6416m Input Module. Fourteen VDC Slots are available system-wide, regardless of the current network mode (Auto or Manual). Virtual Data Cables are not affected by the network sample rate, channel activation settings, or gain settings.

When a module requests to activate a Virtual Data Cable, the Control Master checks the entire network to ensure that the requested VDC is available. Depending on the type of VDC requested, one or more VDC Slots must be available before the request can be granted.

When a VDC Slot has a valid input assignment, the Control Master broadcasts this information to the entire network. Each module in the network will display the In Use LED for any valid Virtual Data Cable input.

See the VDC info elsewhere in this User Guide for help configuring and using the fourteen available Virtual Data Cables.

Configuring a VDC

To assign a Virtual Data Cable Slot to one of the VDC ports on the 6416m rear panel, first select an available VDC Slot using the inc/dec buttons below the VDC Slot readout. (VDC Slots with inputs that are currently in use somewhere in the network will have the In Use dot lit.) Use the selector button to scroll through the choices in the Assign Port list. The control data type LED and the Enter/Cancel LED will flash. Press the **ENTER** button to assign the port, or press **CANCEL** to exit.

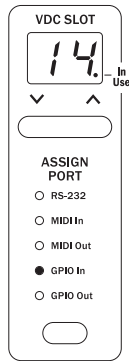

VDC Slot 14 on the 6416m is set to input GPIO data from the rear-panel jack to the network.

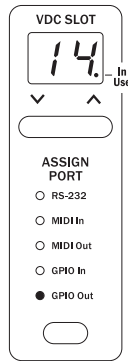

A remote Pro64 device is set to output GPIO data.

To output control data that originates at the 6416m from another Pro64 module elsewhere in the network, select the same numbered VDC Slot on the remote Pro64 device that contains the data from the 6416m. Set the remote device's VDC type by pressing the selection button to highlight the data type and light its LED. Press **ENTER** to complete the VDC assignment.

To deactivate a VDC Slot, use the selection button to scroll through the data types until none of the LEDs is lit, and then press the **ENTER** button.

GPIO

GPIO (General Purpose Input/Output) can be used to send contact closure or voltage-type control signals through the network. Four input and four output blocks are provided. Each terminal block can be individually wired. GPIO inputs can be individually configured to be either Isolated or TTL.

GPIO Configuration DIP Switches

Each of the four GPIO Input blocks can be set to either Isolated or TTL operation using the configuration switches to the left of the terminal blocks.

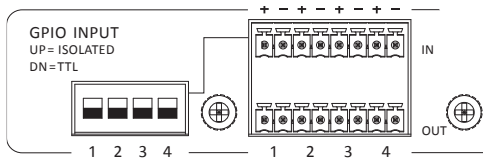

The Isolated/TTL configuration switches only apply to the GPIO inputs.

With the switch in the down position, the input is set to TTL. Use this setting for voltage-type signals. GPIO inputs set for TTL operation can handle signal voltages up to 5 Volts.

The up position (Isolated) sets the input to accept on/off switch signals. **Do not use the Isolated setting with voltage-based signals.** See the GPIO Specifications later in this document for additional configuration information.

GPIO Terminal Blocks

Each GPIO input or output has a positive and negative contact that can be wired as needed. Four of each are provided. Only a small screwdriver is required.

MIDI In, MIDI Out

Two MIDI (Musical Instrument Digital Interface) ports, In and Out, are provided on the 6416m. Each is capable of transferring any type of MIDI-compatible data. Pro64 devices do not process or filter MIDI data in any way.

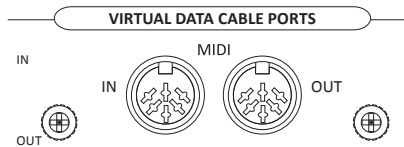

Both MIDI ports in the VDC section can be used simultaneously.

One MIDI In per Pro64 device can be assigned to a VDC Slot. An unlimited number of Pro64 modules can make use of the MIDI data by assigning MIDI Out to the VDC Slot with the same number as the input source.

RS-232 Port

The Pro64 RS-232 VDC ports allow a pair of devices to transfer control data at rates up to 57.6k baud across the Pro64 network. Using Virtual Data Cables for RS-232 always requires two VDCs because RS-232 data transfers require communicating devices to be set up in a handshaking pair. Note that RS-232 communication is point-to-point, meaning that a maximum of seven RS-232 sessions (14 total devices) are possible when using Pro64 Virtual Data Cables.

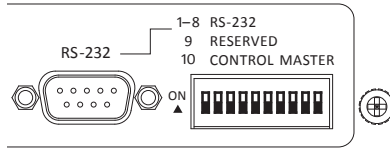

The first eight switches on the DIP switch block are used to set the RS-232 baud rate.

The RS-232 port is also used for computer communication with Pro64 devices for firmware updates and other Managed Mode applications.

The RS-232 port on the 6416m uses a 9-pin DB9 connector and eight of the ten DIP switches in the DIP switch block (the remainder are used for system functions).

RS-232 Configuration DIP Switches

RS-232 communication is configured using the first eight switches in the DIP switch block. Switches 1-4 set the baud rate and switches 5-8 are used to set data, parity, and stop bit options. Switches 9 and 10 are reserved for system use.

Switch	Function	Off	On
1	Baud Rate bit 3	<i>See Baud Rate chart</i>	
2	Baud Rate bit 2		
3	Baud Rate bit 1		
4	Baud Rate bit 0		
5	Data Bits	7	8
6	Parity Low/High	No parity	Parity
7	Parity Even/Odd	Even	Odd
8	Stop Bit	1	2
9	<i>Reserved</i>		
10	<i>Control Master</i>		

To set a DIP switch to the **ON** position, push it upwards.

RS-232 Baud Rates

To set a baud rate, determine the appropriate baud rate for data transfer by referring to the external send/receive devices' documentation. Set both devices to communicate using the same baud rate. Finally, set the Pro64 devices to the same baud rate and activate the VDCs using the front-panel interface.

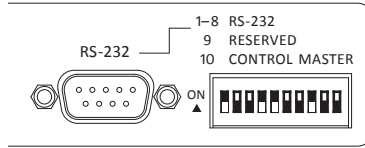

Here, the 6416m is set for a 57,600 baud RS-232 transfer with 8 data bits, no parity, and stop bit set to 2. (Black indicates the switch handle.)

The following table lists the DIP switch settings for the available RS-232 baud rates.

Baud Rate	Switch			
	1	2	3	4
1200	off	off	off	off
2400	off	off	off	on
4800	off	off	on	off
7200	off	off	on	on
9600	off	on	off	off
14400	off	on	off	on
19200	off	on	on	off
28800	off	on	on	on
38400	on	off	off	off
57600	on	off	off	on
31250 (MIDI)	on	off	on	off

Control Master DIP Switch

In the RS-232 DIP switch block on the 6416m, switch #10 is used to set the module as the network's Control Master. Only one module can be designated as Control Master in a Pro64 network.

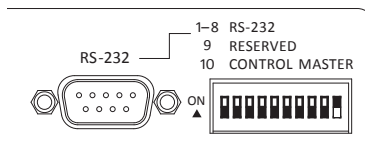

When switch #10 is in the up position, the 6416m becomes the network's Control Master. (Black indicates the switch handle.)

To set the 6416m as the Control Master, start with Pro64 network devices powered off. Set switch #10 to the up position. Power up the 6416m and the rest of the network devices. The red Control Master LED on the front panel of the 6416m should be lit indicating that it is now the network's Control Master.

- ✓ **NOTE:** Be sure that only one Pro64 device is set to be the network Control Master.

RCI Front Panel Components

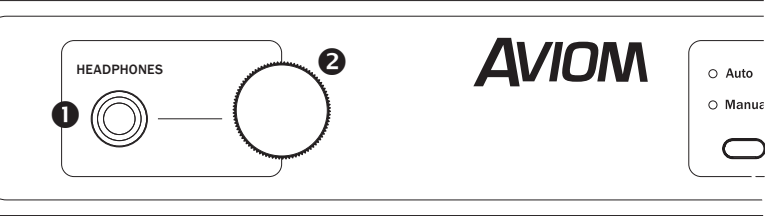

1. Headphone Input Jack
2. Headphone Monitor Volume Control

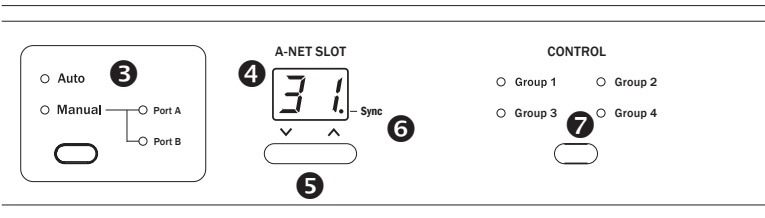

3. Network Mode Selection
4. A-Net Slot
5. Inc/Dec Slot Selection
6. Sync Indicator
7. Control Group Selection

RCI



1

2

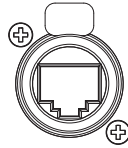

CONTROLLER

1. A-Net LED
2. Controller Input for MCS

RCI Rear Panel Components

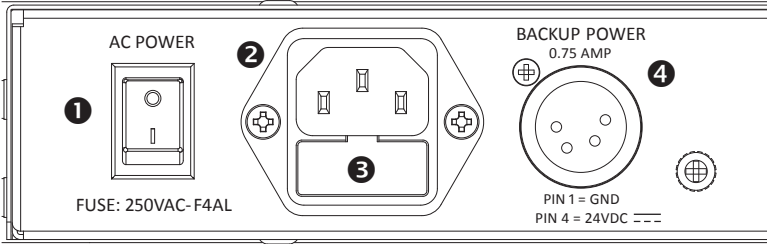

1. Power On/Off Switch
2. IEC Power Inlet
3. Fuse Holder
4. Backup DC Power Inlet

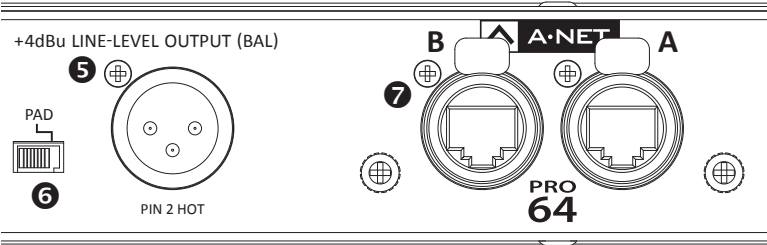

5. Balanced Line-Level Monitor Output, XLR
6. Output Pad Switch
7. A-Net Ports, EtherCon Jacks

RCI Front Panel Features

The RCI provides a network access point for remote control of the 6416m. Any number of RCI Remote Control Interfaces can be installed anywhere in a Pro64 network, providing multiple control access and monitor points. The Control Group function on the 6416m and RCI allows control of active mic channels to be divided among up to four different simultaneous users and control points. The RCI can also be used simultaneously with m-control for Yamaha digital console to provide multiple points of control.

The RCI can also be used as a stand-alone monitor station; any Pro64 network audio resource can be selected (from the RCI or MCS) and monitored using the built-in headphone and/or line-level XLR mono outputs. MCS Mic Control Surfaces can be connected and disconnected from the RCI without affecting network behavior.

This section describes the features and functions of all front-panel components of the RCI Remote Control Interface.

Headphone Input Jack

The 1/4-inch TRS headphone input jack accepts any stereo headphone or earphone. The mono audio signal monitored here is determined by the currently selected A-Net Slot as shown on the RCI front panel. The selected A-Net Slot being monitored is always available at both the headphone jack and the rear-panel XLR line-level output. Only one Slot can be monitored at a time; the headphone jack always monitors a mono signal.

Monitor Volume Control

This knob controls the volume for the headphone jack and has no effect on the fixed level of the rear-panel line-level monitor output.

Network Mode Selection

The Network Mode section of the interface has a set of LEDs that indicate the current network mode being used: Auto or Manual Mode. The current network mode is set at the Control Master. In Auto Mode, no network settings are available, the Pro64 network manages all channel allocation and VDC resources. It does not matter which rear-panel A-Net port is used to connect the RCI to the network.

In Manual Mode, the user can select a specific A-Net port from which to draw channel information.

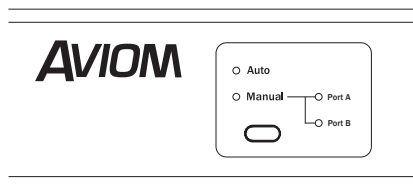

Auto and Manual Mode LEDs and Port selection options on the RCI

A-Net Slot

The A-Net Slot display shows the network Slot that is currently available to be monitored by the headphone and rear-panel XLR outputs. Any active network Slot can be monitored, even if its content is not coming from a microphone input module.

The display will scroll sequentially through all available Slots (as determined by the current network sample rate) with two variations: double dashes with and without the Sync dot on.

The display will show a double dash (--) when no Slot is selected. No audio is monitored at the headphone and XLR outputs in this case.

The display will show a double dash with a dot (--.) to indicate that the RCI Slot to be monitored is selected remotely from the MCS Mic Control Surface. The display will reflect the Slot being monitored plus the dot when Slots are selected from the MCS. The RCI and MCS will remain in sync until the user selects a channel directly from the RCI front panel.

Inc/Dec Slot Selection

Use the inc/dec button below the numeric Slot display to select an active Slot to be monitored.

Selecting a Slot directly from the front panel of the RCI while the RCI and MCS are in sync causes the synced operation to stop.

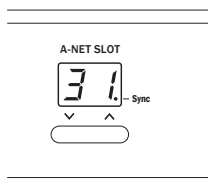

A-Net Slot selection and sync indication

Sync Indicator

The dot in the Slot Selection display is used to indicate that Slot selection is being controlled from the MCS Mic Control Surface. Slot selection will remain in sync until the user selects a Slot directly from the RCI front panel.

To activate the sync function and allow Slot selection to be controlled from the MCS Mic Control Surface, use the inc/dec buttons on the RCI to scroll until "--." (double dash with a dot) is shown in the display. At this point, sync is activated and the MCS has control of Slot selections. Slot numbers recalled from the MCS will be reflected on the RCI display and that Slot's audio will be output to both the headphone and XLR connectors for monitoring.

Control Group Selection

Each 6416m Mic Input Module in a Pro64 network can be set to one of four Control Groups. This allows multiple zones of mic modules to be controlled by different users if desired.



Control Group selection

A mic preamp must be set to one of the four Control Groups in order to be controlled by an MCS. An RCI must also be set to the same Control Group as the mic preamp you wish to control.

Use the selection button to cycle through the selections, Groups 1-4 and Off. Setting an RCI or 6416m Control Group to the Off state will stop it from being accidentally changed or edited by any remote device. (Its front panel still can be edited locally, however.)

Only mic channels in the currently selected Control Group can be edited with an MCS Mic Control Surface connected to an RCI.

A-Net LED

The blue LED found within the A-Net logo of the RCI functions as the network activity indicator. When a module is powered up, its A-Net LED will flash while a request to enter the network is sent to and then processed by the

device designated as Control Master. Once a module is enumerated and is part of the Pro64 network, the blue A-Net LED will light solid. The LED will remain lit as long as valid A-Net network data is received.

The A-Net LED will flash during a firmware update when the module being updated is part of an active network. When a module is being bench configured (it is not part of an active network), the A-Net LED will be off during the firmware update. (Check the Aviom website for current firmware updates.)

Controller Input for MCS

Plug the optional MCS Mic Control Interface into the Controller port on any RCI in the network to monitor and edit active channels on mic modules set to the currently selected Control Group.

The Controller input sends bidirectional data plus power to the connected MCS Mic Control Surface.

Do not plug Pro64 A-Net signals into the Controller Input port.

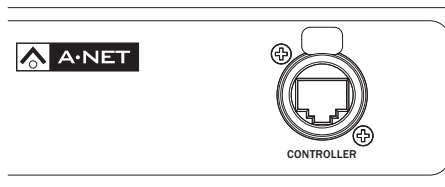

Controller port for the MCS

Cables Connecting the RCI and MCS

Use any standard Cat-5e UTP (or better) cable to connect the MCS to the RCI. Cable length can be up to 400 feet (120 meters). Use cables with standard RJ45 plugs or those equipped with the heavy-duty locking EtherCon connector.

RCI Rear Panel Features

All RCI rear-panel features and functions are described in this section.

AC Power

Pro64 modules use switching power supplies that can operate at 100-240V and from 50-60Hz, meaning that they can be used with most of the world's AC power systems by simply changing the line cord. The RCI is equipped with a standard grounded IEC power inlet (with fuse), which can accept the interchangeable IEC power cord.

Fuse

The fuse holder is spring-loaded and has space for two fuses, one main and one spare (optional). Press the fuse holder cover to access the fuse. When checking or replacing a fuse, always power off the Pro64 unit and remove the line cord from the AC power source.

Always replace the fuse with one of the same rating as that being changed.

Backup DC Power

For applications where a backup power source is required, the RCI is equipped with a backup DC power inlet using a locking 4-pin XLR jack. A DC power supply capable of outputting 24VDC $\pm 5\%$ at 0.75 amp is required. In the locking XLR plug, connect pin 1 to ground and pin 4 to the 24VDC supply. Nothing should be connected to pins 2 and 3.

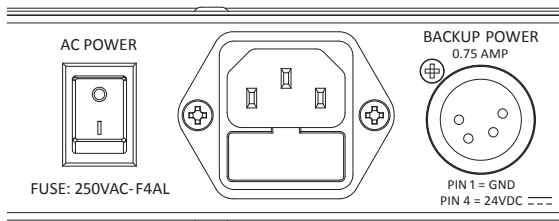

The RCI can be powered via its internal power supply or an optional external 24 volt supply.

Both internal AC and external DC power sources can be connected simultaneously. The AC Power switch only controls the AC inlet.

Balanced Line-Level Monitor Output

The RCI outputs the currently selected Slot as a +4dBu line-level audio signal that can be connected to a mixing console or any other device capable of taking in a line-level audio signal.

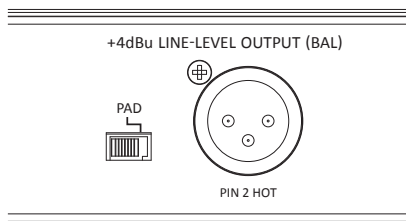

The RCI outputs the currently selected Slot as a +4dBu mono line-level audio signal.

The output of this jack is a fixed level and is not affected by the front-panel headphone monitor output level control.

Output Pad Switch

The Pad switch lowers the output level of the +4dBu line-level signal present at the monitor output jack by 21dB. Move it to the right to enable the 21dB pad.

The output pad switch has no effect on the front-panel headphone monitor's output level.

A-Net Ports

Two EtherCon jacks are provided for A-Net connections, labeled A and B. Connections can use standard RJ45-style cables or cables outfitted with the locking EtherCon connector. Refer to the section on network modes for additional information about using these jacks.

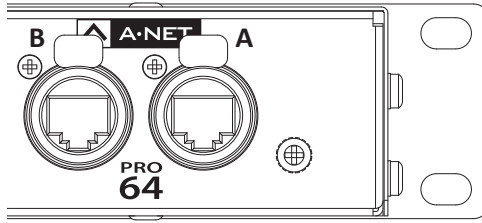

Two A-Net ports are provided, labeled A and B.

When configuring a system, connect a Cat-5 cable to either the A or B port when using Auto Mode. In Manual Mode the user must set the front panel Receive Port settings to reflect where the cables are connected on the rear panel in order to get the desired result.

Do not plug the MCS Mic Control Surface into the rear panel A-Net ports of the RCI Remote Control Interface. Plug the MCS into the RCI front panel Controller port only.

MCS Components

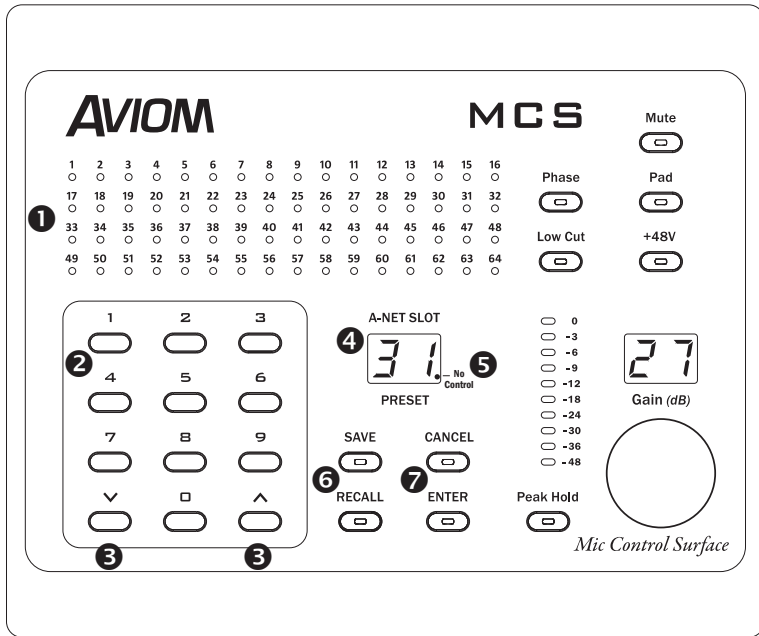

1. Bicolor LED Channel Level Meters
2. Numeric Keypad
3. Inc/Dec and Up/Down Selection Buttons
4. A-Net Slot Display
5. "No Control" Indicator Dot
6. Save and Recall Buttons
7. Cancel and Enter Buttons
8. EtherCon Control Port Connector (on the rear panel)

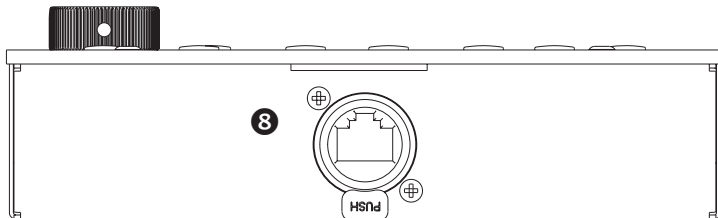

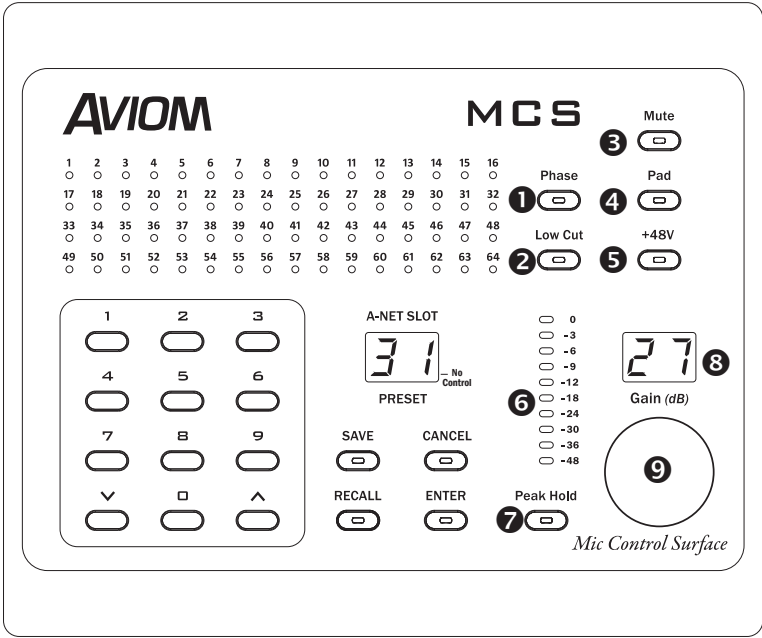

1. Phase Button
2. Low Cut Button
3. Mute Button
4. Pad Button
5. +48V Phantom Power Button
6. High Resolution Meter
7. Peak Hold Button
8. Gain Display
9. Gain Control

MCS Features

The MCS is used to edit 6416m mic preamp settings and save/recall presets remotely. A single MCS connected to an RCI can be used to control up to 64 channels of 6416m input channels, regardless of their location in the Pro64 network. Multiple control points can be provided by installing more than one RCI Remote Control Interface in a Pro64 network.

All changes made from the MCS are immediately reflected on the front panel of all 6416m modules in the same Control Group. The MCS can be disconnected from the network as needed without affecting network behavior. Its features are described in detail below.

Channel Level Meters

The MCS has 64 channel level meters that use bicolored LEDs. Green LEDs are used for normal signal levels and red is used to indicate channel clipping.

The MCS will show the current level of all active network channels regardless of whether the channel is a microphone signal or not.

Numeric Keypad

The numeric keypad can be used to select an active Slot for monitoring or editing and is also used to select a mic pre Preset for save/recall.

You can enter a single digit for numbers below 10 or enter a leading zero (02, 07, etc.).

If you make a mistake when entering a Slot number, you can continue to enter numbers any time prior to pressing the **ENTER** button. The interface will move digits to the left in the numeric display as they are entered. For example, entering **4, 2, 3, 7, ENTER** will recall Slot 37, the last two digits entered.

When saving or recalling a mic pre Preset, only numbers from 1 to 16 are valid.

Inc/Dec Selection Buttons

The two arrow buttons in the numeric keypad area are used for inc/dec or up/down functions when selecting Slots and Presets.

To select a Slot, press inc or dec to scroll sequentially through the available Slots (the exact numbers displayed will be determined by the current network sample rate). Follow the selection rules above; press **ENTER** or simply wait for the Slot to be automatically selected. Press **CANCEL** to return to the last selected Slot.

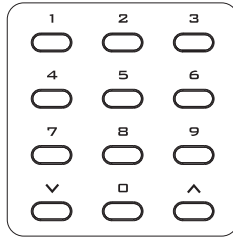

The numeric keypad with inc/dec buttons

A-Net Slot Display

The two-digit A-Net Slot display shows the currently selected active network Slot. Remember that any Slot can be selected for level monitoring, but only mic preamp channels in the same Control Group can be edited from the MCS. When selecting a new Slot, this display will show Slot numbers as they are entered from the keypad; only the last two digits entered are used according to the numeric keypad rules described above. Press **ENTER** to recall a Slot or press **CANCEL** to return to the previously selected Slot.

The Slot display is also used to show Preset numbers when saving or recalling a mic pre Preset. Only numbers from 1 to 16 are used for preset management.

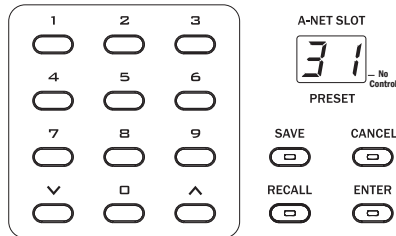

The A-Net Slot display is next to the numeric keypad

Select a Slot

To select a Slot to be monitored or edited, enter a number corresponding to the Slot you wish to select and do one of the following:

- Press **ENTER** to immediately display the selected channel/Slot number, or
- Do nothing; after a short pause, the channel/Slot will be selected automatically.

Only Slot numbers from 1-64 (at 44.1/48kHz), 1-32 (at 88.2/96kHz), or 1-16 (at 176.4/192kHz) are valid. Entering any invalid number (for example, an out-of-range Slot) will return the display to the last legal Slot number displayed.

No Control Indicator

The No Control indicator dot in the lower right corner of the A-Net Slot display will light to indicate that the currently selected Slot cannot be edited. Active input channels assigned to Slots in the Pro64 network that are not coming from mic input modules can be monitored but cannot be controlled or edited.

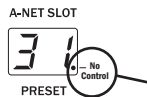

The No Control indicator dot will be displayed whenever the selected Slot cannot be edited from the MCS.

The No Control indicator dot will also light when a selected mic preamp Slot is not in the same Control Group that is set on the RCI you are currently connected to.

Save and Recall Buttons

The Save and Recall buttons on the MCS are used to store or recall one of the sixteen available presets in controllable mic input modules. Remember that the Presets are saved in the 6416m modules and not in the RCI or MCS.

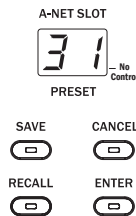

Save/Recall and Enter/Cancel buttons are below the Slot display.

To use the Save and Recall functions from the MCS, any 6416m Mic Input Modules that you want to control need to be set to the same Control Group that the RCI Remote Control Interface is set to.

When using the Save and Recall functions from the MCS, all 6416m Mic Input

Modules will save or recall the same numbered Preset simultaneously.

6416m Mic Input Modules set to different Control Groups will ignore Save/Recall requests from any RCI/MCS set to a different Control Group number.

See page 54 for additional information on the use of Presets and the interaction of the Control Group settings.

Cancel and Enter Buttons

Some mic pre editing operations, such as using the pad or phantom power features, require the use of the Enter button to confirm an action.

The pair of buttons marked **ENTER** and **CANCEL** on the MCS will be used to confirm Slot selections, edits, saving/recalling mic pre Presets, or to exit an edit request. The buttons' LEDs will flash whenever the user is required to press one of these buttons in order to continue with an operation or edit.

MCS Channel Strip

The channel strip section of the MCS includes the high resolution meter and the individual controls for the preamp channel parameters. All operations described below apply to the currently selected mic pre channel. Changes to channel strip parameters made from the MCS will be reflected on the front panel of the 6416m Mic Input Module where the channel originates.

Note that editing channels that do not originate on Pro64 mic preamp modules is not possible. Non-mic channels from Pro64 line-level, digital, or console card modules can be monitored but cannot be edited.

Gain Display

The two-digit Gain display shows the amount of gain being applied (in dB) for the currently selected mic preamp channel. Remember that only Slots originating on 6416m Mic Input Modules can be edited; the Gain display will be blank for non-controllable Slots.

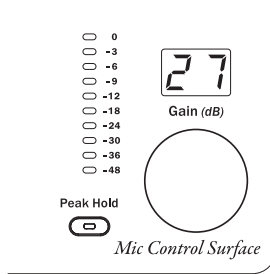

The current gain setting is displayed for any active mic preamp channel when its Slot is selected.

Gain Control

The rotary gain control sets the amount of gain applied to the currently selected mic preamp channel and can be changed in 1dB increments. The gain display will flash until the 6416m has processed the command sent from the MCS. Gain settings for each channel of the 6461m are saved within a mic preamp Preset.

Mute Button

Use the Mute button to silence an active mic preamp channel while leaving it active in the network. Press the **MUTE** button once to enable the mute function; press **MUTE** again to release the channel from the muted state.

The Mute state is saved as part of a mic pre Preset.

Phase Button

Press the Phase button to invert the polarity of the input signal on the selected mic preamp channel. Use the Phase button to eliminate anomalies that occur when using two or more microphones on the same source (such as a drum kit).

To change the phase, press the **PHASE** button once; its yellow LED will light to indicate that the function is enabled. It is not necessary to press Enter. To return the audio on the selected channel to its original state, press **PHASE** again, the LED will go out.

The state of the Phase button is saved with a mic pre Preset.

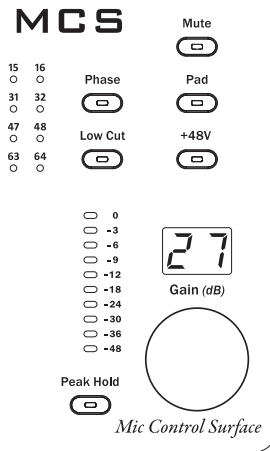

The channel strip, high resolution meter, and gain settings

Low Cut Button

The Low Cut button applies a bass rolloff filter centered at 85Hz to the selected channel. Use this to eliminate low frequency interference such as microphone handling noise, rumble, etc.

Press the **Low Cut** button once; its yellow LED will light to indicate that the function is enabled for the selected channel. Press **Low Cut** again to turn the filter off. It is not necessary to press the Enter button.

The Low Cut filter's state for each channel is saved with a mic pre Preset.

Pad Button

To lower the level of the selected channel by 24dB, press the **PAD** button. Since changes to the overall level of a channel caused by the use of the Pad can cause abrupt changes in level, the use of Enter/Cancel is required to confirm the operation. The use of the pad will generally be required when a line-level signal is connected to a 6416m input.

To turn a channel's Pad on, press the **PAD** button once. The Enter and Cancel LEDs will blink. Press **ENTER**; the Pad is on. Press the **CANCEL** button to exit without turning the Pad on.

To turn the Pad off for a channel when it is enabled, press the **PAD** button. The Enter and Cancel LEDs will blink. Press **ENTER**; the Pad is turned off. Press **CANCEL** to exit without turning the Pad off. Mic pre Presets save the Pad state for each channel.

+48V Phantom Power Button

Phantom power for devices such as condenser mics is available for each 6416m mic preamp channel. The use of Enter/Cancel is required to confirm a change when using +48V phantom power.

To turn phantom power on, press the **+48V** button once. The Enter and Cancel LEDs will blink. Press **ENTER**; the phantom power is on. Press the **CANCEL** button to exit without turning phantom power on.

To turn a channel's phantom power off when it is enabled, press the **+48V** button. The Enter and Cancel LEDs will blink. Press **ENTER**; the phantom power is turned off. Press **CANCEL** to exit without turning the +48V phantom power off.

The on/off state of the +48V phantom power is saved for every channel in each mic pre Preset.

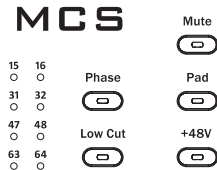

Using the phantom power and pad functions requires the use of the Enter/Cancel buttons.

- ✓ **NOTE:** Consult the documentation that came with your phantom powered mic or other device to avoid damaging the product. Improper application of +48V phantom power can damage the circuitry of some older ribbon microphones, for example.

High Resolution Meter

Channel level is displayed in the high resolution meter for the selected Slot even when the selected Slot does not originate on a Pro64 mic preamp module.

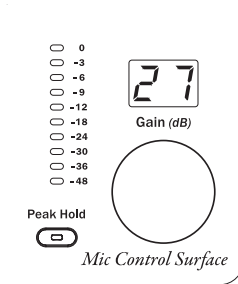

The high resolution meter and Peak Hold button

Peak Hold Button

When on, the Peak Hold function will show and hold the highest level (including any clips) that has occurred on the high-res meter as well as any clips that may have occurred on active Slots (displayed using the 64 bicolor LEDs). To use the Peak Hold function, press the **PEAK HOLD** button once; its LED will light.

Press the **PEAK HOLD** button again to clear the last displayed peaks and turn the hold function off.

Controller Connector

The rear panel of the MCS contains an EtherCon® connector for connecting the MCS to an RCI Remote Control Interface. The cable connected to this port supplies data and DC power for the MCS.

Cables Connecting the MCS and RCI

Use any standard Cat-5e UTP (or better) cable to connect the MCS to the RCI. Cable length can be up to 400 feet (120 meters).

Avoid damage to the product. Do not plug the MCS Mic Control Surface into anything other than the RCI Remote Control Interface front-panel control port.

Building a Pro64 Network

Configuring a Pro64 network involves connecting input and output modules with Cat-5e cables, setting A-Net Slot ranges, and activating input channels. Any number of 6416m Mic Input Modules and RCI remote Control Interfaces can be connected and located anywhere in a Pro64 network.

Choosing a Network Mode

When designing a network, deciding which network mode to use—Auto or Manual—can be made simpler by assessing the total audio channel requirements for an application at a given sample rate first.

If you want to build a 48kHz network, for example, that requires no more than 64 total audio channels, choose Auto Mode; this is the easiest to implement. The network takes care of most of the management tasks automatically.

If the network is larger than 64 channels at 48kHz—for example, a 56x16 digital snake for a live stage to front-of-house application—choose Manual Mode. Pro64's Manual Mode offers the most flexibility but requires more care when connecting modules and configuring input and output routing.

Connecting Pro64 Modules

Start by setting one (and only one) device to be the network Control Master. Because there are some operations that can only be executed at the Control Master, be sure that the module designated as the Control Master is accessible. Once all modules in the network are enumerated (indicated by illuminated A-Net LEDs), choose a network mode (Auto/Manual), set A-Net Slot ranges on each module, and activate audio channels and VDCs as needed.

When adding input modules to an existing audio network running in Manual Mode, it is best to add modules that are not pre-configured with active channels and/or VDC Slots in use to avoid unwanted overwriting of A-Net Slots. Pro64 output modules' audio settings do not cause conflicts with the configuration of audio input resources but its VDC settings *can* impact the network.

Basic Routing

To output the mic/line audio inputs connected to the 6416m, the module must be connected to another Pro64 device somewhere in the network that can output its data. This Pro64 device can be a standalone analog or digital module or a console interface card such as the 6416Y2 console card for use in Yamaha® digital products supporting the MY expansion card format.

The diagrams that follow use generic input and output module icons. Any Pro64 I/O device can be substituted unless otherwise noted. Connect the RCI at any convenient location in the diagrams that follow to provide a monitor station and remote control of 6416m mic preamp parameters.

Auto Mode Connections

In Auto Mode, the 6416m's A-Net ports on the rear panel can be connected to other Pro64 devices interchangeably. In the following examples, network performance and functionality are unaffected by the changes in cabling.

Example 1: Port A connected to Port B

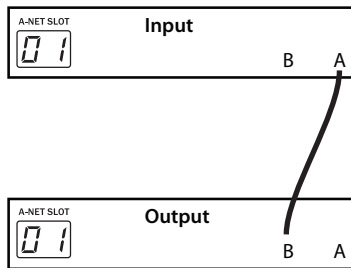

The A-Net cable can be connected to either Port A or Port B. Reversing the A-Net connections causes the same results. Either port can be used to expand the network.

Up to 16 inputs can be activated on the 6416m Mic Input Module. Other Pro64 devices can be connected using either Port A or Port B to expand the network. In both cases, the active channels will be available at the output module.

Remember that the entire 64-channel A-Net stream (at 48kHz) is always received and transmitted through every Pro64 module. The A-Net Slot Transmit or Receive settings simply tune a module in to a specific range of Slots within the network.

When using remote control via the RCI and MCS, the RCI can be connected to any open A-Net port.

Example 2: Port B connected to Port A

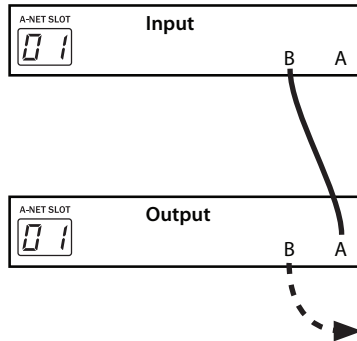

In this diagram, note that additional Pro64 modules can be connected to any available port as indicated by the dotted line.

Here, Port B of the input module is connected to Port A of the output module, the opposite of Example 1. The same results can be achieved by connecting Port A on the input module to Port A on the output module and by connecting Port B on the input module to Port B on the output module.

Since the network is operating in Auto Mode, all A-Net ports carry the full bandwidth of the network. There is no “input” or “output” A-Net port on I/O modules or hubs.

Digital Copies in Auto Mode

Any number of digital copies (also referred to as digital splits) can be created by simply connecting additional Pro64 output devices and setting them to the same A-Net Slot range. In Auto Mode, the order and location of the modules in the network does not matter; output modules can be connected before or after any input module. Optionally, Pro64 modules can be connected in parallel using a Pro64 merger hub such as the MH10 or MH10f.

Example 3: One input module and three digital copies in Auto Mode

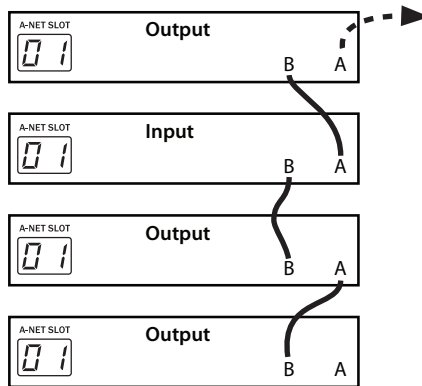

In this example, note that the A-Net connections between devices can be any combination of the A and B ports. Any open port can be used to connect additional Pro64 devices.

The order of the Pro64 modules connected in series in Example 3 above can be changed without affecting the ability of the network to distribute the same incoming audio channels to all three output modules shown. A-Net ports always transmit and receive the entire network (audio and VDC data) at all times.

The rules are the same when larger networks are created. Simply set a different A-Net base Slot on the I/O modules to use more A-Net Slots as needed. Cables can be connected to any available A-Net port, A or B. Remember that in Auto Mode that the maximum number of active channels at 48kHz will be 64. I/O modules can be mic, line, digital, or console cards as needed.

Adding a Merger Hub in Auto Mode

For more wiring options, an A-Net Merger Hub such as the MH10 or fiber-capable MH10f can be added to a network. Using a merger hub enables parallel connection of A-Net devices. Multiple merger hubs can be used to simplify gear rack wiring and distribution of digital signals amongst the various subsections of a digital audio network.

- ✓ **NOTE:** Standard Ethernet networking products are not compatible with Pro64 products. Use only A-Net compatible devices.

Example 4: One input module and three output modules connected using an MH10/MH10f in Auto Mode

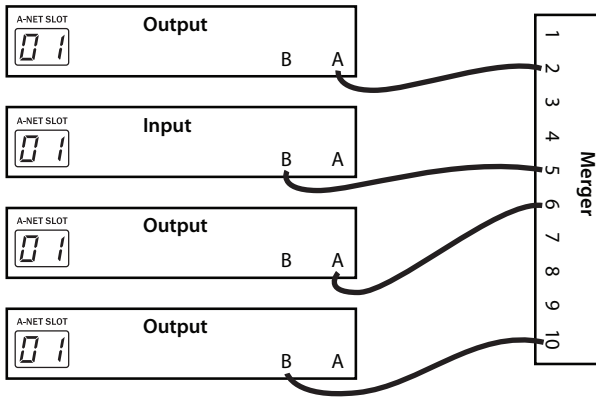

In Auto Mode, modules can be connected to any port on the MH10.

Note that in the example, it does not matter which A-Net port (A or B) on the I/O modules is connected to the MH10. Likewise, on the MH10, the choice of A-Net port (1 through 10) does not matter. Any audio channel made active on the input module in the diagram will be available to all output modules. Remember that the modules shown in the diagrams can be analog, digital, or console interface cards as needed. Likewise, the RCI can be connected to any available port to add remote control capabilities.

Manual Mode Connections

When creating bidirectional networks that require more than 64 channels (at 48kHz), Manual Mode is the answer. Unlike Auto Mode, Manual Mode requires that the user pay attention to which A-Net port (A or B) is used when connecting network cables to each module. As implemented in the Pro64 Series of products, A-Net is a truly bidirectional stream of up to 64x64 channels at all times.

In the examples that follow, the diagrams will indicate the specific A-Net port on an I/O module that is in use. Input modules such as the 6416m can send active audio channels to Port A, Port B, or both Ports A and B.

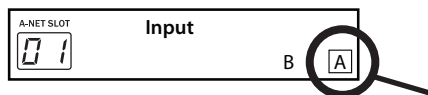

Port A is being used to send active audio inputs into the network, indicated by the square surrounding the "A" Port.

Example 5: One input module and two output modules in Manual Mode

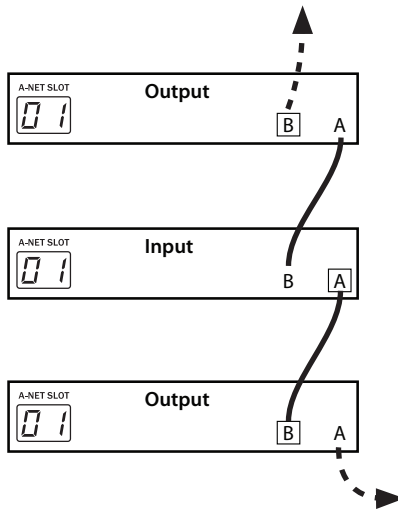

The input module transmits its audio data via Port A (marked with a square surrounding the port name). Only the lower Pro64 output module can make use of those audio channels.

In the example above, showing I/O modules in the middle of a Pro64 network, the input module in the center of the diagram is set to transmit its active audio data to Port A, using the A-Net Slot range starting at 1. The output module below it is set to listen to any A-Net data that arrives on its Port B. The output module at the top of the diagram is set to listen to data arriving at its Port A.

Since the input module is directing its data to Port A, only the bottom module can output the audio channels made active on the input module. Again, the example assumes that all modules are set to the same A-Net Slot range. Remember that all network audio is always transmitted and received at each A-Net port. The module's Slot Range selection simply tunes into a specific range of channels.

A-Net merger hubs can be added as need to simplify cabling, extend the distance between Pro64 modules, and to provide split points and redundant cable paths.

Remember that when using Manual Mode the RCI Remote Control Interface also needs to have its A-Net Receive ports set properly in order to edit channel strip parameters of 6416m modules in the Pro64 network.

Example 6: Two input modules and two output modules, 16x16

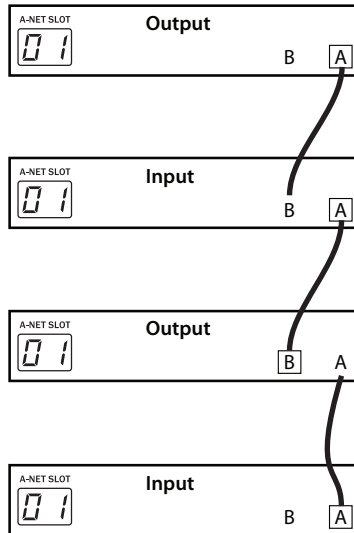

Audio from the Pro64 input module at the bottom of the diagram is heard at the output module shown at the top of the diagram.

In this example, two input modules are set to the same A-Net Slot range. Both are set to transmit their A-Net data out of Port A. Unique data flows in each direction in a 16x16 configuration. Each output module will receive data from only one of the input modules in the configuration.

The next example refines this drawing by adding specific locations for the modules in a traditional stage-to-FOH snake system.

As mentioned previously, the input and output modules can be any combination of mic/line analog, digital AES3, or Yamaha format modules and console cards.

Example 7: Audio from the stage is output at the front-of-house mixing console; audio from the FOH console is output on the stage.

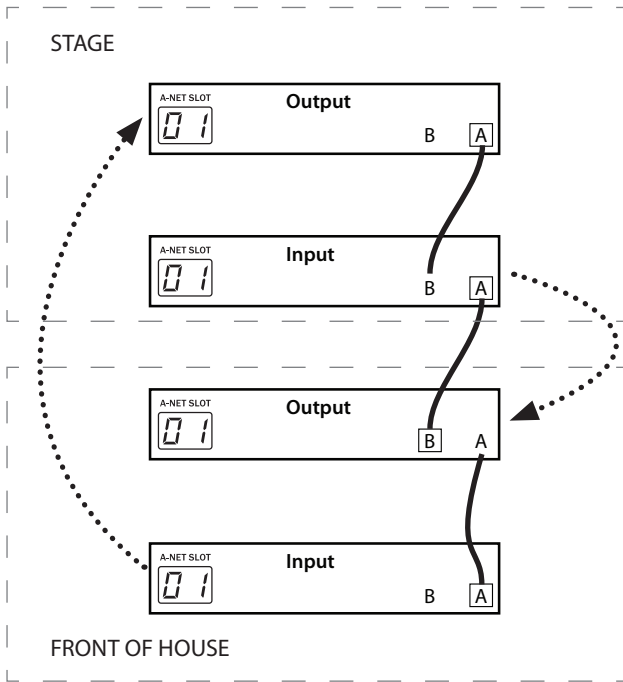

The dotted arrows show the relationship between the input and output modules.

By defining the uses of the audio data from the two input modules in the previous example as stage and FOH, the picture is clearer. Audio from the input module seen at the bottom of the diagram (at FOH) travels up through all the modules in the network; its audio is available at the output module at the top of the diagram.

Audio from the input module on the stage travels through the network to the FOH position where it is output to the mixing console by the Pro64 output module there.

Digital Copies in Manual Mode

Creating a digital split in Manual Mode follows most of the rules defined for Auto Mode splits. Any output module connected in series to an existing output module can output the same audio as long as the A-Net Slot range and A-Net Receive Port settings are configured properly, and as long as no other input modules overwrite the audio.

Example 8: Adding a digital split of the FOH signals

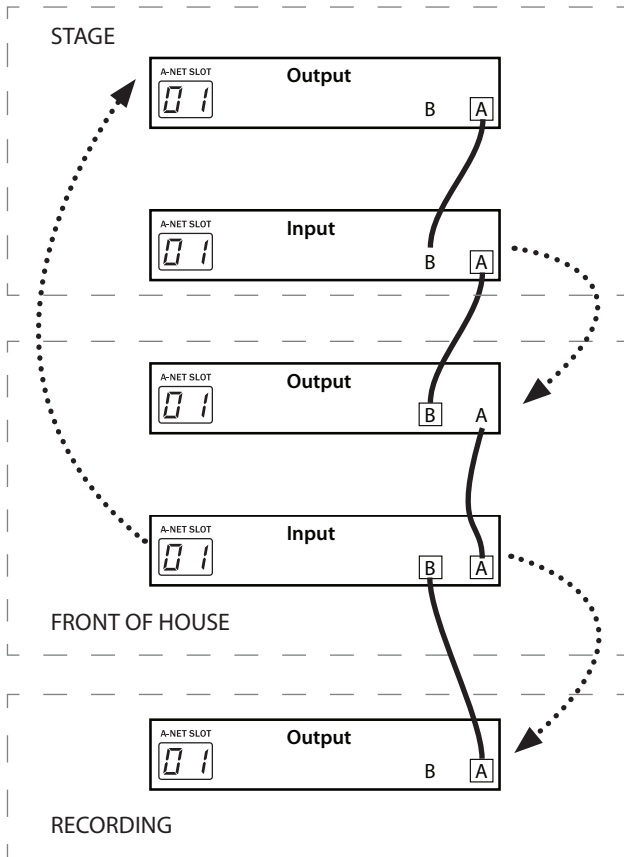

The input module at FOH transmits its audio data out of both A-Net ports, providing a digital split.

In the previous example of a stage and front-of-house system, adding a digital copy of the FOH engineer's mix inputs for a recording system can be accomplished by connecting a Pro64 output module to the input module at

front of house. Unlike Auto Mode, however, this input module needs to be set to send audio data to its A-Net Port B in order to make the digital split work.

The example assumes that all modules are set to the same A-Net Slot range. By setting the FOH input module to transmit its A-Net data to Port A *and* B, the A-Net data flows in two directions: to the output module on stage and to the output module in the recording area. Both output modules are set to receive A-Net data via Port A.

Digital audio arriving at the front of house location from the stage is replaced with the content generated by the FOH engineer that is connected to the Pro64 input module at FOH when those same Slots are transmitted to the recording area via the same Slot range.

To send the stage audio to the recording system instead, set the input module at front of house to transmit its data on Port A only. By doing this, the audio from the stage flows through all the modules to the recording system.

Remember that A-Net merger hubs such as the MH10/MH10f can be added as needed to simplify cabling, extend the distance between Pro64 modules, and to provide split points and redundant cable paths.

Example 9: A digital copy of the stage signals

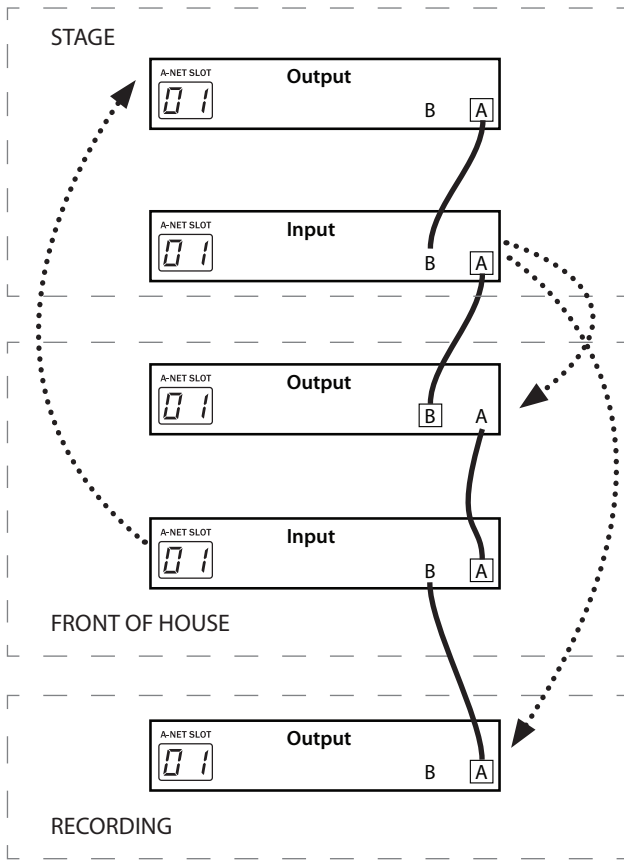

The input module at the front-of-house position is set to transmit its A-Net data out of Port A only. The dotted lines show the relationship of the input and output modules.

By changing the A-Net Transmit port settings on the input module at front of house to transmit only on Port A, audio from the stage can be output in the recording area.

VDC Configuration

Pro64's Virtual Data Cables provide an easy way to distribute control signals throughout a network, greatly expanding the possibilities for using and distributing MIDI, GPIO, and RS-232/422 control signals. (Not all Pro64 modules have the same VDC complement.)

A-Net provides the ability to send these control data over greater distances than previously possible with traditional analog connections. And with MIDI and GPIO connections, infinite numbers of copies of the control data are available everywhere in the network.

Fourteen VDC Slots are available at all times; VDCs are not affected by the current sample rate or network mode. The makeup of the VDC Slots is user defined; no VDC Slots are reserved for specific data types.

The VDC interface includes the numeric VDC Slot display, the inc/dec buttons used for VDC Slot selection, the Assign Port list of VDC data types, and a selection button for choosing a VDC data type for the currently selected VDC Slot.

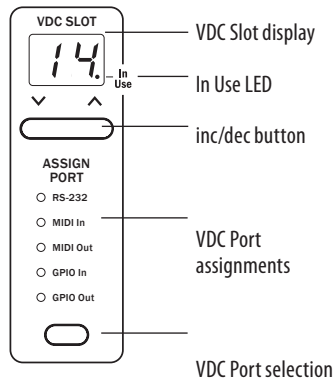

The VDC section of the user interface is used to assign VDC ports and data types.

VDC Slot Display

The two-digit VDC Slot display shows the currently selected VDC Slot (1 through 14). The In Use LED within the display indicates that a selected VDC Slot has an active input somewhere in the network. If only an output is assigned to a particular VDC, its In Use LED will not be lit.

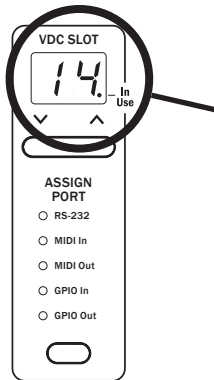

When a rear-panel VDC port has been assigned to a VDC Slot, its In Use LED will be on.

Selecting a VDC Slot is done with the inc/dec buttons below the display. Pressing the inc/dec buttons will cause the display to scroll up or down, and will wrap at the end of the numeric list.

As the VDC Slots are displayed, any VDC Slot with an active input will light the In Use LED. If the In Use LED is not lit for a selected VDC Slot, no input is assigned to that VDC Slot and all of the VDC type LEDs in the Assign Port list will be unlit when the VDC out has been assigned locally.

The available VDC data types for the 6416m are:

- RS-232
- MIDI In
- MIDI Out
- GPIO In
- GPIO Out

VDC In Use LED

The VDC In Use LED serves to indicate that a Virtual Data Cable Slot has a current active input assignment. Output assignments for MIDI Out or GPIO Out will not light the In Use LED.

The In Use LED will light whenever a valid assignment (GPIO In, MIDI In, or RS-232) has been made anywhere in the network. The VDC Slot can only be used for the assigned data type until it has been deactivated at the point in the network where the input source has been assigned.

Assigning a VDC Slot

The act of assigning a VDC Slot maps one of the rear-panel hardware VDC I/O ports to a Virtual Data Cable. To assign a VDC port to a VDC Slot, two actions are required. First an available VDC Slot must be selected, and second, one of the VDC data types from the Assign Port list must be assigned to that VDC Slot.

To select a VDC Slot to activate, scroll through the list to a numbered location that does not have the In Use LED lit.

To assign a data type, use the selector button below the Assign Port list to select the desired VDC data type, for example MIDI In. The LED next to the selected type will light; the Enter/Cancel LED will also start to flash. Press **ENTER** to enable the VDC Slot; press **CANCEL** to exit without assigning a VDC port.

To output VDC data from the network to a rear-panel VDC port, choose a VDC Slot with the appropriate data type for the application (for example, MIDI). Active network VDC Slots are displayed with the In Use LED on.

Once selected and configured, the rear-panel I/O connection for the selected VDC can be used to transfer control signals.

Deactivate an Active VDC Slot

To release an active input assigned to a VDC Slot, use the inc/dec button to scroll to the active VDC Slot. (Its In Use LED should be on.) Press the selector button below the Assign Port LEDs until no VDC data type LED is lit. The Enter/Cancel LED will be flashing. Press **ENTER** to deactivate the VDC Slot assignment and make that VDC Slot available to other modules in the network.

- ✓ **NOTE:** Only VDC inputs need to be deactivated to free Virtual Data Cable resources. VDC outputs do not reserve any of the fourteen Virtual Data Cable resources.

Advanced Functions

The available advanced functions for the 6416m Input Module are listed in the table below. No Advanced Functions are available on the RCI or MCS modules.

Number	Function
1	Clear A-Net Resources - Active Audio Channels and Virtual Data Cables
2	Mute all input channels
3	Unmute all input channels
4	<i>Reserved for future use</i>
5	<i>Reserved for future use</i>
6	<i>Reserved for future use</i>
7	<i>Reserved for future use</i>
8	<i>Reserved for future use</i>
9	Password Lock/Unlock
10	Password Edit - Set New Password
11	Sample Alignment - Get Info
12	Sample Alignment - Measure New Value
13	Sample Alignment - Use Stored Value
14	Sample Alignment - Use Default Value
15	Pro64 Operating System Update
16	Restore Factory Defaults

Function Button

The Function button is used in combination with other front-panel buttons to access features of the user interface such as setting/changing the module's password, network-wide password protection, and other Control Master settings. Functions are mapped to the channel activation buttons; the exact labeling of the buttons is determined by the I/O configuration of the module (8-channel versus 16-channel, etc.).

To access the advanced functions, press the **FUNCTION** button; its button LED will light. Next, press the channel activation button that corresponds to the desired function, followed by the **ENTER** button to activate it.

To exit without selecting a Function, press the **CANCEL** button. Pressing any

front-panel button other than a channel activation button after the Function button will also cancel the Function request.

Clear A-Net Resources

This Function clears currently active audio channels, stereo links, and VDC assignments on a module for the current network mode, Auto or Manual. The module must be unlocked to use this feature. The network cannot be in Managed Mode.

To clear A-Net resources, press the **FUNCTION** button. The Function button and Enter/Cancel LEDs will flash. Press the **CHANNEL 1 ACTIVE** button; the channel 1 Active button, VDC port assignment list, and all currently active channels flash. Press **ENTER**. The A-Net resources are cleared.

To exit without clearing the current A-Net resources in use, press the **CANCEL** button.

Mute/Unmute all Channels

Functions 2 and 3 can be used to mute and unmute the 6416m audio channels.

To mute all 16 channels of the 6416m, press the **FUNCTION** button. The Function button and Enter/Cancel LEDs will flash. Press the **CHANNEL 2 ACTIVE** button and then press **ENTER**. All channels are muted simultaneously.

To exit without muting the 6416m channels press the **CANCEL** button.

Once the 6416m channels have been muted by using Function 2, use Function 3 to unmute all channels.

To unmute all 16 channels of the 6416m, press the **FUNCTION** button. The Function button and Enter/Cancel LEDs will flash. Press the **CHANNEL 3 ACTIVE** button and then press **ENTER**. All channels are unmuted simultaneously. Active channels will then be available to all output modules in the network that are set to the same Slot range.

To exit without unmuting the 6416m channels press the **CANCEL** button.

Password Lock

Every Pro64 network can be password protected. Each module in the network stores a unique password which can be used to lock the network when that module is set to be the network Control Master. A password consists of a four-number sequence based on the channel active buttons, for example "2-13-7-10." The default password for all I/O modules is "1-1-1-1."

To lock the network, press the **FUNCTION** button on the Control Master

module. The Function button and Enter/Cancel LEDs will flash. Press the **CHANNEL 9 ACTIVE** button; a unique LED pattern flashes to warn the user that the network is about to be locked. Key in the four-number network password using the channel Active buttons. Press **ENTER** to complete the operation. A special forward sweeping LED sequence is displayed in the channel meters to confirm that the network is being locked.

Press **CANCEL** to exit without locking the network.

The network will be locked until the network password is provided. The **EDIT LOCK** button will light to indicate that the network is locked.

Password Unlock

When a Pro64 network is password protected, a specific four-number password code is required to unlock it. The network can be unlocked only at the Control Master.

To unlock the network, press the **FUNCTION** button on the Control Master module. The Function button and Enter/Cancel LEDs flash. Press the **CHANNEL 9 ACTIVE** button. Key in the four-number network password using the channel Active buttons and then press the **ENTER** button. The channel level meters display the reverse of the password lock LED sequence to confirm that the network is now unlocked. Pro64 modules can be edited or reconfigured as needed.

To exit the unlock request without unlocking the network, press **CANCEL** to exit.

Set a New Password

Each Pro64 module can store a four-number network password. However, the password lock/unlock feature can only be used from the network Control Master. Passwords can be changed only when the network is unlocked.

The password is a four-number sequence created using the numbered channel activation buttons 1-16 on the front panel. Passwords can include repeated numbers (such as the default factory-supplied password of 1-1-1-1). When creating a password, any string of numbers can be used, but note that only the last four button presses are stored.

To set a new password, press **FUNCTION** and then the **CHANNEL 10 ACTIVE** button. Key in a four-number button sequence and then press **ENTER**. The channel buttons flash to indicate that the new password has been set. Pressing the **CANCEL** button will exit the function and leave the original password intact.

Sample Alignment

All digital networks that allow daisy-chained connectivity need to compensate for sub-millisecond latency build-up between devices when data is retransmitted. In the majority of cases, there is no audible effect (as the individual delays are very small), but without compensation, these small variations in latency can become an issue in certain applications as the network grows in size.

On power up, each device in the network will calculate a sample alignment value based on the current sample rate and will apply it as long as the network is running. The next time the network sample rate is changed or the system is power cycled, a new value will be calculated and locked in. This sample alignment value will be referred to as the *default value* in the text that follows. Using the default value will offer the simplest method of operation.

However, to guarantee repeatable latency down to the microsecond, the user has the option of measuring the sample alignment amount for a given sample rate and then applying that measured value every time the network is powered up. This is referred to as a *stored value* in the text that follows. By using these stored values, the Pro64's unique software guarantees consistent delays between each component of the network.

Sample Alignment Status

The sample alignment query, Function 11, can be performed on the Control Master or any remote unit in the network. The network can use the default value (created at the time of power-up) or a stored value.

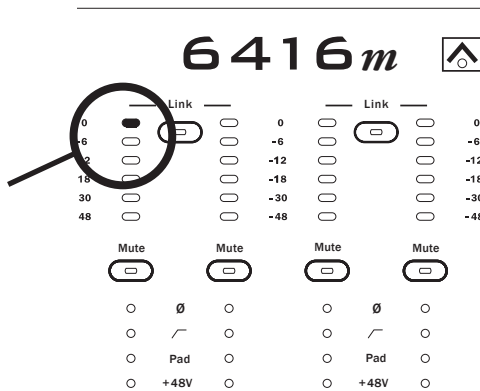

In Advance Function 11, the red LED indicates that the system default sample alignment values are being used.

To get sample alignment info, press the **FUNCTION** button, followed by the

CHANNEL 11 ACTIVE button. Press **ENTER**; the A-Net Slot display is used to indicate the current value in use.

- The A-Net Slot display reads “0” to indicate that the system’s default values are being used. (This is set with Function 14.)
- The A-Net Slot display reads “1” to indicate that stored values are being used. (This is set with Function 13.)

Measure New Sample Alignment Value

To generate a new sample alignment value, use Function 12. This Function can only be performed at the Control Master when the network is unlocked.

Press the **FUNCTION** button, followed by **CHANNEL 12 ACTIVE** button. The sixteen channel meter LEDs and the Enter/Cancel LED will flash, indicating that this operation will replace the currently stored value. Press **ENTER** to measure and generate a new sample alignment value, or press **CANCEL** to exit without updating the stored value. A forward sweep of the level LEDs indicates that the function is complete.

Values are stored in each module’s memory but are not put into use until Function 13 (Use Stored Sample Alignment Values) is performed, which activates the stored sample alignment values. The module must be the network Control Master to use its stored value. Use Function 11 to get info on the current values in use.

When the stored sample alignment value is being used, a new sample alignment value should be calculated each time the network sample rate is changed, or when the system configuration changes. (Changes include the addition/subtraction of Pro64 modules, different wiring schemes, etc.)

Use Stored Sample Alignment Value

When a new sample alignment value has been generated and stored, Function 13 can be used to activate and lock in this value for use throughout the network. This Function can only be performed at the Control Master when the network is unlocked.

To use the stored value, press the **FUNCTION** button, followed by the **CHANNEL 13 ACTIVE** button. The Enter/Cancel LED and the sixteen yellow channel meter LEDs will flash. Press **ENTER** to use the stored value, or press **CANCEL** to exit without changing the sample alignment value (the system reverts to using the default value).

The stored sample alignment value remains in force even when the network is power cycled. When the network is reconfigured or when the sample rate is changed, a new value should be calculated using Function 12 described above.

Use Default Sample Alignment Value

The system calculates a sample alignment value to be used as the default every time the network is powered up, or when the sample rate is changed. Function 14 can be used at the Control Master to set the network to use the default value. (Function 13 is used to instruct the system to use a stored value.)

To set the network to use the default sample alignment value, press **FUNCTION**, followed by the **CHANNEL 14 ACTIVE** button. The sixteen channel meter LEDs and the Enter/Cancel LED will flash. Press **ENTER** to use the default value, or press **CANCEL** to exit without changing the current value. A forward sweep of the level LEDs indicates that the function is complete.

Use Function 11 (Get Sample Alignment Info) to display the current value in use—default or stored.

Restore Factory Defaults

Function 16 restores the 6416m to its factory default settings.

To restore the factory default settings, press **FUNCTION** followed by the **CHANNEL 16 ACTIVE** button. The Enter/Cancel LED and the sixteen red channel level LEDs will flash, indicating that this function will interrupt normal network operation. Press **ENTER** to continue and recall the factory default settings, or press **CANCEL** to exit, leaving the current settings in place.

The Factory Default settings are:

- A-Net Slot is set to 1.
- Auto Mode is selected.
- Sample Rate is set to 48kHz.
- All audio channels are deactivated for Auto, Manual, and Managed Modes.
- All stereo links are deactivated for Auto, Manual, and Managed Modes.
- Gain is set to 0dB.
- Phase is off.
- The Low Cut filter is off.
- The Pad is off.
- +48V phantom power is off.
- Managed Mode is deactivated.
- Edit Lock is set to off.
- Password protect is off.
- The system password value for the module being reset is "1-1-1-1".
- All Virtual Data Cables are deactivated.

The 6416m Control Master status is controlled by the rear-panel DIP switch #10 setting. This is not changed when the factory defaults are restored.

VDC configuration for GPIO type—Isolated or TTL—is not reset. VDC baud rate, parity, and stop bit settings for RS-232 communication are not reset. These are hardware settings configured via the DIP switches in the VDC section of the rear-panel part of the interface.

Restoring factory defaults is a local function; only the module where the function is engaged will be reset.

Firmware Update

Pro64 modules can be updated in the field using a PC and the Pro64 Update Tool application. Modules can be updated over A-Net, while part of an active audio network, or in local mode where no other modules are connected at the time the update is being performed (such as may be required for a bench configuration when setting up modules prior to installation).

Updating a module requires the Aviom Pro64 Update Tool application, a PC host computer with RS-232 connection capability, a null modem DB9 cable, and the update file for the particular Pro64 device being updated. Refer to the Aviom website for information about the availability of the latest firmware upgrades and feature updates. See page 62 for baud rate information.

Update Connections

To update modules via A-Net, a host computer is connected to the network's Control Master via the RS-232 port in the Virtual Data Cable section of the rear panel. Individual modules are then selected and updated from within the Pro64 Update Tool. Updates can be applied to the Control Master or a slave device.

To update via A-Net, make sure that no RS-232/422 or MIDI VDC resources are configured on the Control Master. (Refer to the Virtual Data Cable information elsewhere in this document.) Then, enter Managed Mode by pressing the **MANAGED** button on the Control Master.

To update modules locally, the computer is connected directly to the module being updated, via the RS-232 port as described above. The Pro64 Update Tool application must also be set to its local update mode. (See the Pro64 Update Tool Help file for more information.)

Baud rates for data transfer must be set the same on the Pro64 device and PC host running the Pro64 Update Tool. Refer to the VDC RS-232 baud rate info elsewhere in this document to learn how to set the baud rate parameters. On the Pro64 module, RS-232 must be configured for 8 data bits, no parity, and one stop bit. Also, refer to the firmware update instructions that come with the Pro64 update application for additional information on setting up the PC host.

Firmware Update - Local

Function 15 enables a Pro64 module to receive new firmware from a host PC connected to the RS-232 port on the module's rear panel. Updates can be applied to a Pro64 module set to be a Control Master or slave device.

To enable firmware updates on the module, press **FUNCTION**, followed by the **CHANNEL 15 ACTIVE** button. The Enter/Cancel LED and the channel level

LEDs will flash to indicate that this function will interrupt normal network operation. Press **ENTER** to enable the module to receive new firmware from the PC host. Send the firmware update following the instructions that came with the Pro64 Update Tool. During the update the sixteen red, yellow and green channel meter LEDs will flash in sequence.

When the firmware update has been sent successfully, the module will reset and normal front panel operation will be restored. If for some reason the firmware update fails, refer to the error recovery information below for instructions on how to recover and complete the update.

When a module is being updated locally, the dot in the VDC Slot display will be on, indicating that a local firmware update is in progress.

When a module is waiting for a firmware update to begin, you can exit the firmware update state by pressing the **CANCEL** button. If the firmware update has not yet started, the module will attempt to reset, returning it to normal operation.

- ✓ **NOTE:** Do not press the **CANCEL** button while a firmware update is in progress.

Error Recovery

In case of a partial firmware download or interruption to the firmware transfer (as would happen because of a power failure, computer crash, or by pressing the Cancel button in the middle of a firmware update), the module can still be updated but will need to be powered up directly into the firmware load mode. To do this, hold the VDC Slot decrement (down arrow) button while powering up the unit. Then send the firmware from the computer as described previously.

Firmware Update - via A-Net

To enable a Pro64 module to receive new firmware via A-Net on an active network, the PC must be connected to the RS-232 port on the Control Master. The network must be in Managed Mode to update firmware via A-Net. All network audio will be muted, and front-panel functions will be disabled on the module being updated.

To enable firmware updates, a module must be selected from within the Pro64 Update Tool application, at which point it will be set up to receive new firmware. Send the firmware update following the instructions that came with the update firmware. During the update, the module's sixteen red, yellow, and green channel meter LEDs will flash in sequence. When the firmware update has been sent successfully, the module will reset and audio will be restored.

When a module is being updated via A-Net in an active network, the dot in the A-Net Slot display will be on, indicating that a network firmware update is in progress.

When a module is waiting for a firmware update to begin, you can exit the firmware update state by pressing the **CANCEL** button. If the firmware update has not yet started, the module will attempt to reset, returning it to normal operation.

- ✓ **NOTE:** Do not press the **CANCEL** button or exit the Pro64 Update Tool application while a firmware update is in progress.

6416m Block Diagram

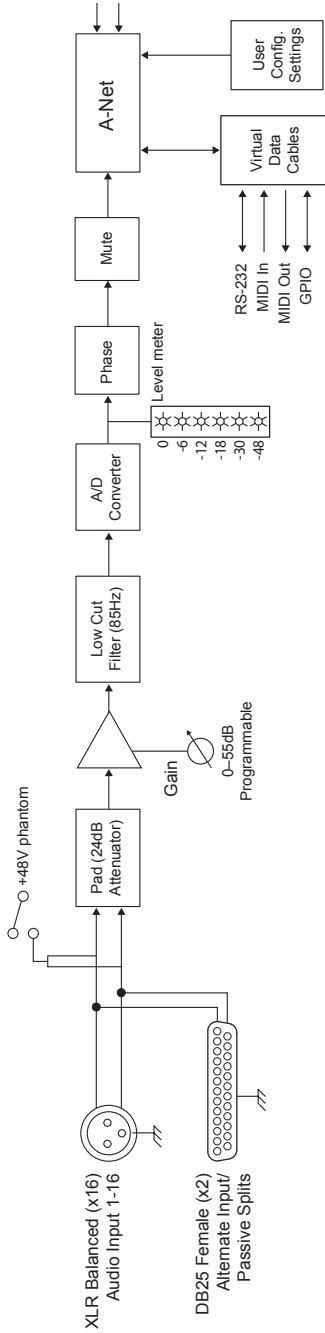

6416m Specifications

Channels	16 inputs	Mic- or line-level
XLR Inputs	Pin 1: Shield; Pin 2: Hot; Pin 3: Cold	
Passive Splitter/ Alternate Inputs	DB25 multipin; audio pinout	
Differential Input Impedance	3.6k ohms	
Input Gain Range	0–55dB, variable, in 1dB increments	
Maximum Input Level resulting in 0dBFS	0dB gain, Pad on = +24dBu 0dB gain, Pad off = 0dBu 55dB gain, Pad on = -31dBu 55dB gain, Pad off = -55dBu	
Pad	-24dB, switchable per channel	
Low Cut Filter	Per channel; -3dB @ 85Hz, 18dB per octave	
Phantom Power	+48V, individually selectable per channel	
Preset Memory	16; saves all channel strip audio parameters	
Sample Rates	1x: 39.7–52kHz; 2x: 79.4–104kHz; 4x: 158.8– 208kHz	24-bit resolution
Frequency Response	+/- 0.3dB 20-23kHz at 48kHz +/- 0.3dB 20-45kHz at 96kHz +/- 0.3dB 20-53kHz at 192kHz -3dB @ 2Hz (at all sample rates)	
THD +N	0.0015% @ 1.0kHz, -10dBFS 0.007% @ 1.0 kHz, -1dBFS	
Dynamic Range (noise floor)	112dB	
Crosstalk	-110dB @ 1kHz, 35dB gain	
Equivalent Input Noise (EIN)	-127dBu	
CMRR (common mode rejection ratio)	78dB @ 1.kHz / 75dB @ 10kHz, typical	

Virtual Data Cables	MIDI In, MIDI Out 5-pin DIN	
	RS-232 DB9 connector; DIP switch configuration	
	GPIO In (x4), Out (x4); terminal block connectors; DIP switch configuration; TTL or isolated	
A-Net	2 EtherCon RJ45 connectors	
A-Net Cable Length	400 feet (120 meters) Cat-5e between devices	
Latency	Analog input to analog output: <800µs	
Maximum Ambient Operating Temperature	+50°C	
Power Supply	100–240VAC	50–60Hz, 55W
	Internal switching type; IEC connector	
Backup DC Power	24VDC +/-5%, 1.6A typical, 2.A max. 4-pin XLR Pin 1: Ground; Pin 2/3: no connect; Pin 4: 24VDC	
	Capable of sourcing 5A of in-rush current for 5ms (0.1ms rise time)	
Dimensions	3U; 19" w x 13" d x 5.25" h (482.6 x 330.2 x 133 .3 mm)	
Weight	15 pounds (5.44 kg)	
All Aviom products are designed and manufactured in the USA.		

Dimensions - 6416m

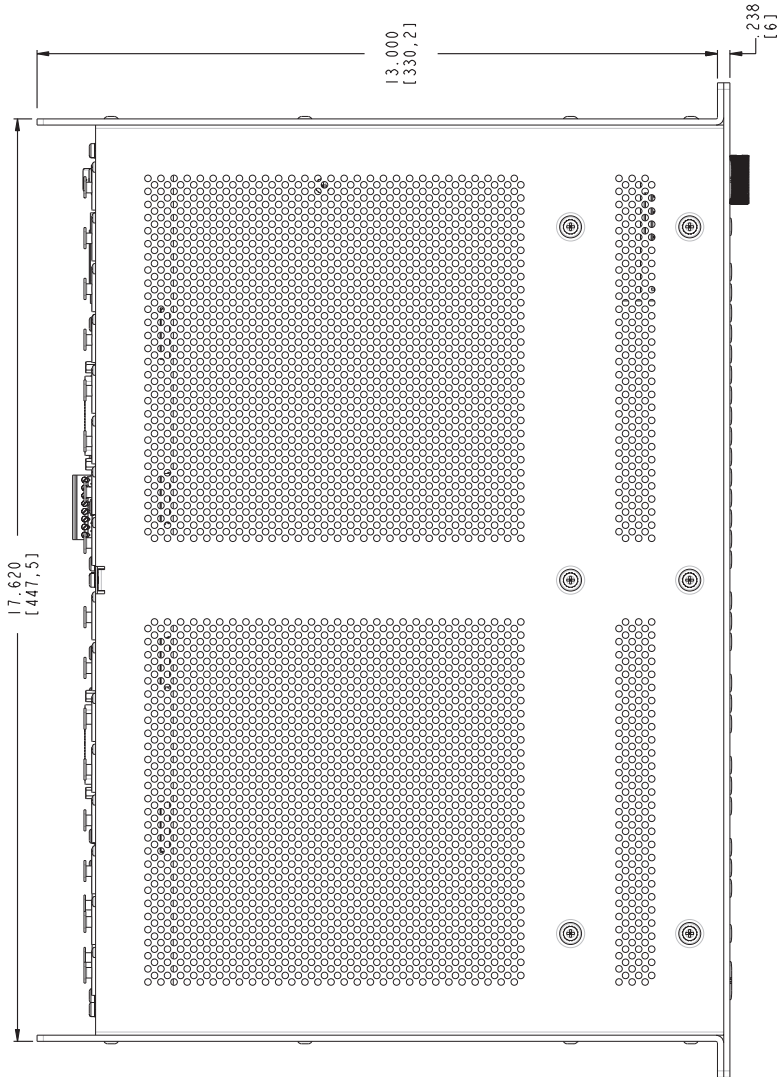

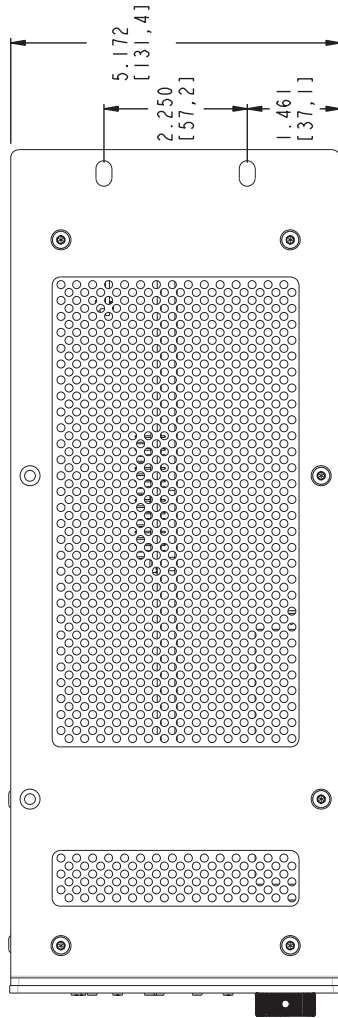
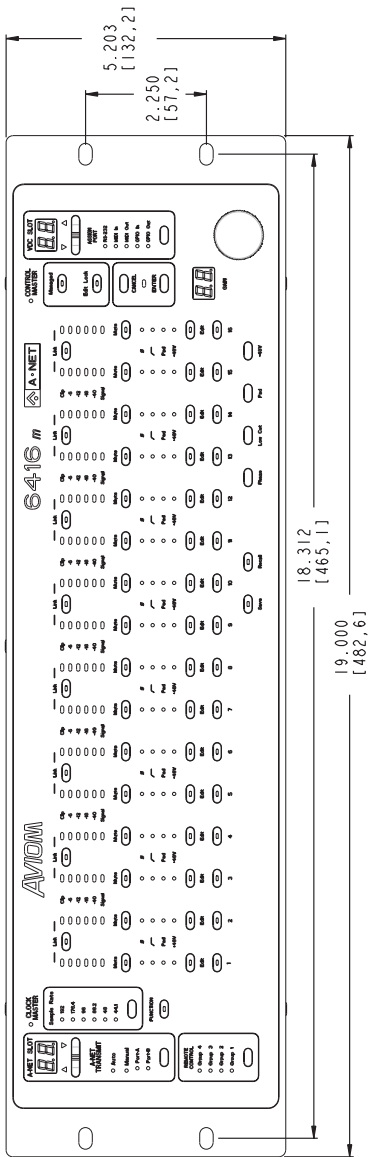

RCI Specifications

Controller Port	Front panel; EtherCon RJ45, Accepts MCS
Headphone Monitor	1/4-inch TRS, mono, with level control
Monitor Output	XLR jack, balanced line level, mono
XLR Output	Pin 1: Shield; Pin 2: Hot; Pin 3: Cold
XLR Output Pad	21dB
XLR Max. Output Level	+4dBu (Pad off), -17dBu (Pad on); rear-panel switch
Max. Ambient Temp.	50°C
A-Net	2 EtherCon RJ45 connectors
A-Net Cable Length	400 feet (120 meters) Cat-5e between devices
Power Supply	100-240VAC, 50-60Hz, 16W Internal switching type; IEC connector
Backup DC Power	24VDC +/-5%, 0.55A typical, 1.A max. 4-pin XLR Pin 1: Ground; Pin 2/3: no connect; Pin 4: 24VDC
Dimensions	1U: 19"w x 8"d x 1.75"h (482.6 x 203 x 44 mm)
Weight	7 pounds (3.17 kg)

Dimensions - RCI

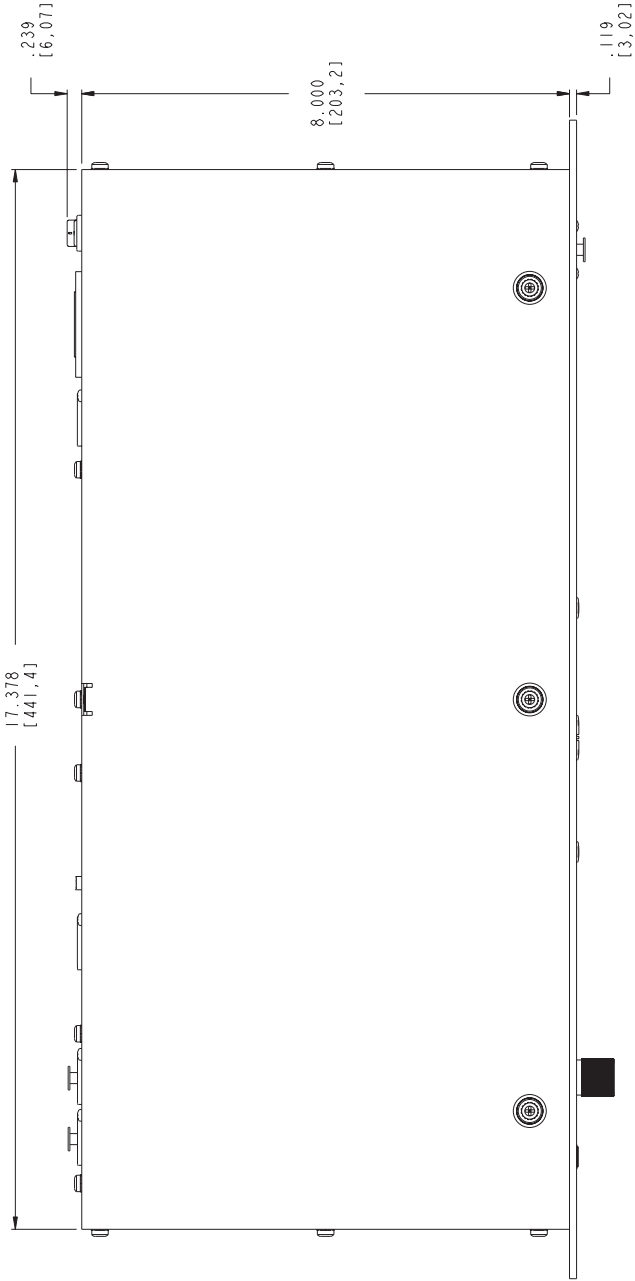

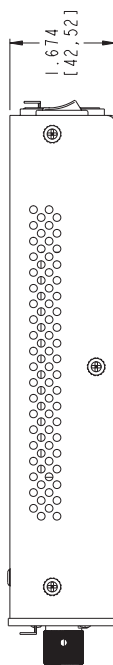
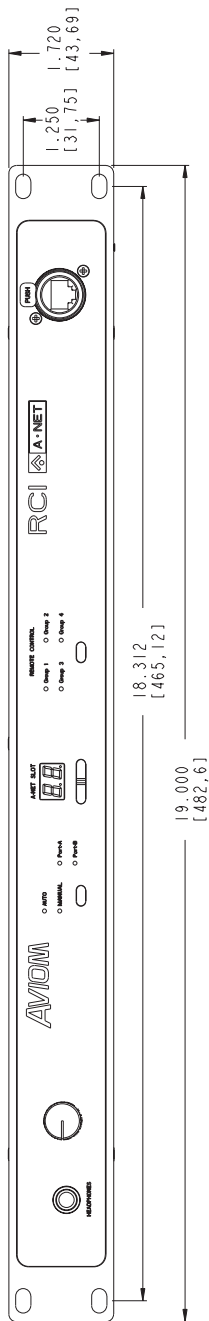

MCS Specifications

Controller Port	EtherCon RJ45, Connects to RCI
Channel Level	64 bicolor LEDs
High Resolution Meter	10-segment, -48 to 0dB
Peak Hold	On/Off
Gain Control	Rotary, per channel, in 1dB steps
Channel Controls	Phase On/Off Low Cut Filter On/Off 24dB Pad On/Off +48V Phantom Power On/Off Mute On/Off
Preset Management	Save/recall 16 presets; stored in the 6416m Mic Input Module
Cable Length between the RCI and MCS	400 feet (120 meters) Cat-5e between devices
Dimensions	6"w x 5"d x 1.5"h (152.4 x 127 x 38.1 mm)
Weight:	2 pounds (0.91 kg)

Dimensions - MCS

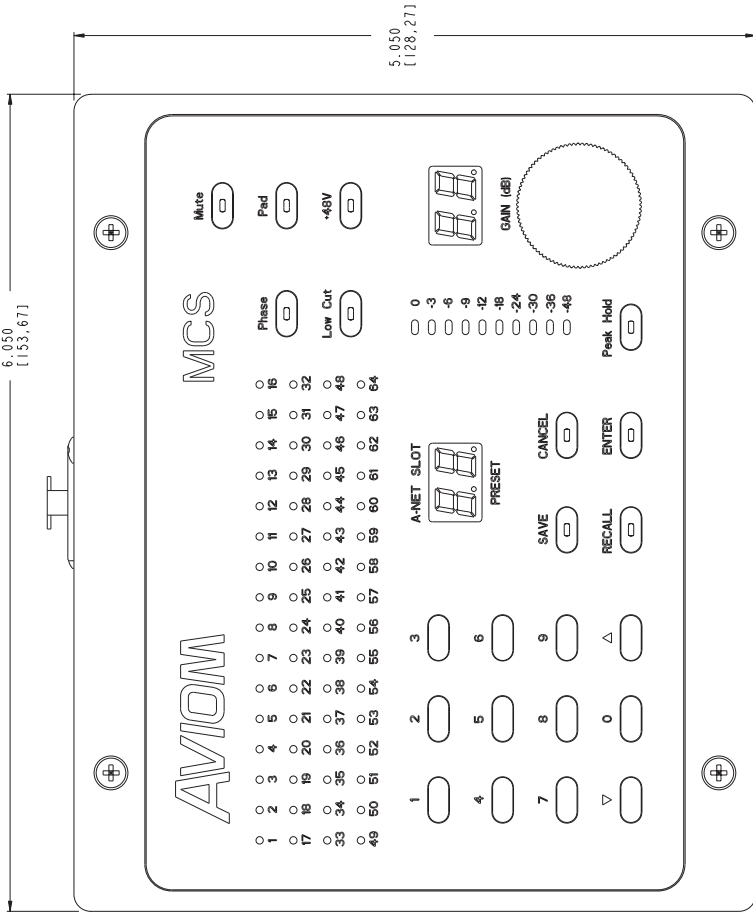

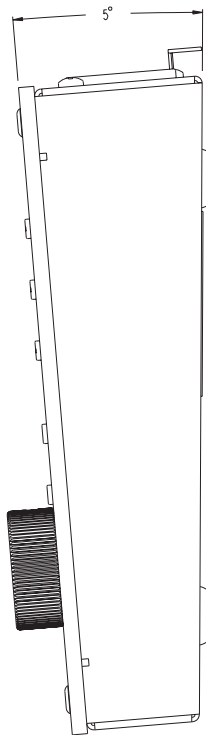
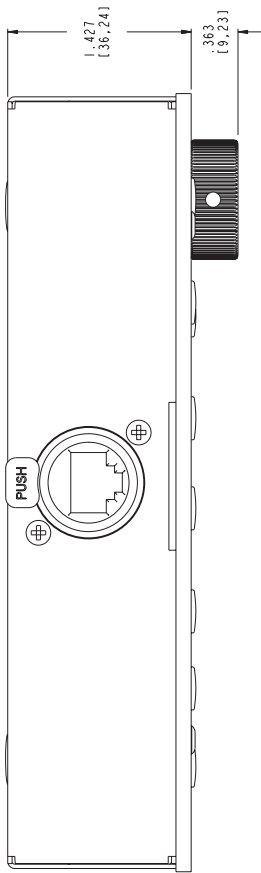

Mounting the MCS

The underside of the MCS has two keyhole openings that allow the MCS to be attached to another surface using only two screws (not included). The diagram below shows the size and location of the two keyhole openings.

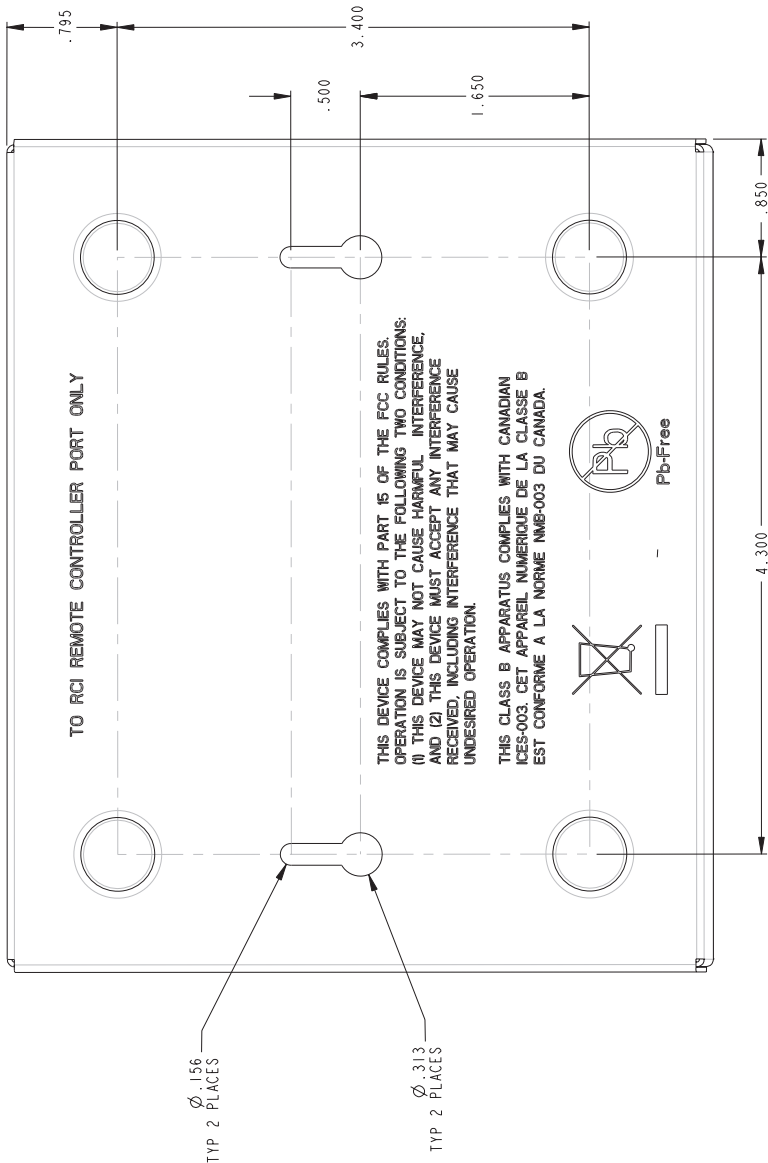

GPIO Specifications

The following table lists the specifications for the General Purpose Input/Output (GPIO) terminal blocks found on Pro64 Series products.

INPUT MODE	Parameter	Conditions	Symbol	Rating
TTL	Input isolation to chassis	within +/-24V of chassis ground	Rin iso	1 Mohms
ISOLATED	Use only with on/off switch-type signals.			
ISOLATED/TTL	Input Voltage	Maximum Low	VIL	2V
		Maximum High	VIH1	17V
	Bandwidth		BW	200Hz
	Output Current (Continuous)	Outputs are overcurrent protected with PTCs.	IL2	330 mA
	Output Current (Peak)	PW=100 msec (1 shot)	I _{fp}	1.5A
	Output isolation to chassis		Rout iso	1.00E+09 ohms
	Output On-State Resistance	IL = 500 mA	Ron	0.85 - 2.5 ohms
	Output Breakdown Voltage		Vbr	60V

Ratings subject to change without notice.

Inputs are reverse polarity protected up to 17VDC.

GPIO Plugs

Plugs used with the GPIO terminal blocks have the following specifications.

Pitch	3.81 mm	
Number of positions	8	
Type of connection	Screw	
Screw thread	M 2	
Conductor cross section AWG/kcmil	minimum 28	maximum 16
Plugs used with Pro64 products are compatible with Phoenix Contact™ part number 1803633 or equivalent.		

MIDI/GPIO Cable Lengths

To meet the EN55103-2 (Electromagnetic Susceptibility/Immunity) Specification, any cables connected to the MIDI and/or GPIO ports must not exceed three meters in length. Use of cables longer than three meters will not guarantee equipment conformance to EN55103-2.

DB25 Audio Connections

Aviom analog input and output modules with DB25 multi-pin connectors are wired to the analog pinout that has become standard in the audio industry (which is sometimes referred to as the Tascam® DA-88 or DTRS pinout). This wiring standard allows easy interfacing with a variety of audio equipment using readily-available multi-pin breakout cables or by incorporating Aviom's PB28 Modular Patch Bay products. Each DB25 jack on an Aviom product carries eight balanced audio channels.

Note that digital devices that transmit AES3 digital audio data (sometimes referred to as AES/EBU) use a different wiring pinout; analog and digital multi-pin breakout cables and/or patch bays are not interchangeable.

Wiring an Analog DB25 Cable

To wire a custom cable for use with the analog DB25 jacks on an Aviom product, use the following table:

Channel Number	DB25 Pin Number		
	Hot	Cold	Ground
1	24	12	25
2	10	23	11
3	21	9	22
4	7	20	8
5	18	6	19
6	4	17	5
7	15	3	16
8	1	14	2
No Connect	13		

DB25 Panel-Mount Connector Pinout

The pins on panel-mounted DB25 jacks found on Aviom products are numbered according to the diagram below.

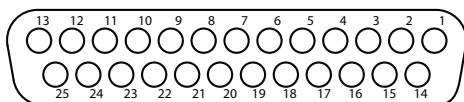

Using DB25 Jacks

The DB25 panel-mount connectors on Aviom products have #4-40 UNC threads. Be sure to get DB25 breakout cables with the correct thread type; forcing the connectors by using the wrong thread type will strip one or more of the mating components rendering them unusable.

Strain relief is suggested when using DB25 cable assemblies. DB25 breakout cables should always be supported when connected to an Aviom product to reduce the risk of damaging the product's rear panel.

RS-232 Cables and Pinout

Using an RS-232 device with Pro64 devices requires a female-to-female DB9 null modem cable (also referred to as a *crossover* cable).

The RS-232 jack in the VDC section of the 6416m has the following pinout.

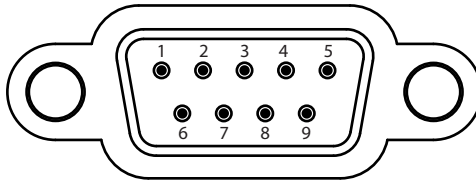

The DB9 connector on a Pro64 device has the pinout seen above.

The table below describes the pinout for the RS-232 and how to build a crossover-type cable. Note that some of the pins are not connected.

RS-232 Connections

Pin	Signal
1	Data Carrier Detect *
2	Received Data
3	Transmitted Data
4	Data Terminal Ready *
5	Signal Ground
6	Data Set Ready *
7	Request To Send *
8	Clear To Send *
9	Ring Indicator *

* *Not supported, no connect*

Wiring a Crossover Cable

The following table can be used to create a crossover cable:

Crossover Cable	
Pin #	Pin #
1 and 6	4
2	3
3	2
4	1 and 6
5	5
7	8
8	7
Pin 9 - no connect	

Index

Symbols

4-pin XLR 56, 73
24VDC supply 51
6416dio 57
6416i 43
6416m DC Requirements 56
6416m Specifications 1

A

A-16II, A-16R
 Personal Mixer 7
A-16II, A-16R Personal Mixer 48
About A-Net 5
AC fuse
 Changing 73
AC Line Conditioning 3
AC Power 56, 73
Activate a channel 47
Activate MCS/RCI sync 71
Active button 43, 44
Active channel 13, 20, 36, 39, 43, 47, 90
Active channels
 Clear 47
Active VDC Slots 99
Adding Pro64 Modules 22
Advanced Functions 100
AES3 6, 24, 92, 124
 DB25 58
AES3 (AES/EBU) 37
AES/EBU 24
Alternate In 1
Alternate Input
 DB25 58
Alternate Inputs 111
AN-16/i 7
AN-16/i-M 7
AN-16/o Output Module 7
Analog input
 Level Meters 47
Analog I/O 23
Analog wiring pinout 58
A-Net 1
 Pro64 Series 5
 Slot assignment 27
 Transmit/Receive settings 87
A-Net base Slot 89
A-Net Cable Length 115
A-Net Distributor 7
A-Net LED 22, 31, 42, 67, 71, 72
A-Net Port 6, 18, 88, 91, 94
 A or B 90
 Manual Mode 90
A-Net Ports 57
 A and B 32, 68
A-Net Receive 94
A-Net Slot 12, 16, 18, 24, 37, 39, 46, 70
 Inc/dec buttons 14
 MCS 76
 Query Functions 44
 RCI 69
 Unavailable, in Auto Mode 46
A-Net Slot Configuration 29, 35
A-Net Slot Display 14, 35, 79
 During software update 109
A-Net Slot number 44
A-Net Slot range 35, 91
 Selecting 14
A-Net Transmit 36
 A-Net 36
A-Net Transmit Port
 Changing 37
A Port 57, 74
Arrows
 Up/down, inc/dec 9
ASI A-Net Systems Interface 7, 48
Assign a VDC input 99
Assign a VDC output 99
Assign Port
 VDC 97, 98, 99
Audio Thru
 DB25 33, 58
Auto LED 36
Auto/Manual Mode LEDs 26
Auto/Manual Mode Selection 25, 29, 40
Auto Mode 6, 18, 20, 40, 46, 69
 Active channels 47
 Available A-Net Slots 13, 18
 Merger Hub 89
Auto Mode Connections 87
Available A-Net Slots 18

B

- Backup DC Power 73, 112, 115
- Backup DC Power Inlet 68
- Backup Power Requirements 56
- Balanced 74
- Balanced Inputs 57
- Base Slot 35, 89
- Band Rates 107
 - DIP switch 64
 - RS-232 63–65
- Bench configure 42, 72
- Bicolored LEDs 78
- Bidirectional 6, 90
- Block Diagram 110
- Blue A-Net LED 22
- BNC Word Clock jack 24
- B Port 57, 74
- Building a Pro64 Network 86
- Button Presses 9

C

- Cable Length
 - MCS to RCI 72, 85
 - MIDI, GPIO 123
- Cable Length RCI-MCS 118
- Cables
 - Cat-5e, Cat-6 5
- Cables Connecting MCS & RCI 72, 85
- Cable specification, Cat-5e 9
- Cancel button 22, 31
- Cancel/Enter Buttons 76, 81
- Cat-5e 2, 9
 - Unshielded Twisted Pair (UTP) 9
- Cat-5e cable
 - Stranded vs. solid 9
- Cat-5e Cable Distance 5
- Cat-6 9
- Certifications ii
- Changing the Sample Rate 25
- Changing Values 9
- Channel 12
 - Mute 48
 - Slot assignment 27
- Channel Activation Button 30, 43, 46, 102
- Channel Activation Rules 47
- Channel Controls, MCS 118
- Channel gain 54
- Channel info 27
- Channel Level Meters 47, 76, 78
- Channel pairing. *See Channel Link*

- Channel range 87
- Channels
 - Clear 101
- Channel-Slot relationship 14
- Channel Strip Functions 46
 - MCS 81
- Cleaning 4
- Clear active channels 47
- Clear A-Net Resources 100, 101
- Clip LED 47
- Clipping
 - Using Peak Hold 85
- Clock 5
 - External 38
 - Jitter and wander 5
- Clock Errors 24
- Clock Master 6, 11, 20, 23, 24, 25, 37, 38, 39
- Clock Master LED 23, 24, 37
- Clock Source 24
 - AES/EBU 24
 - External 24
 - Sample Rate 21
 - Word Clock 24
- CMRR 111
- Computer 107
- Configuring a Network 86
- Configuring a VDC 60
- Connecting Pro64 Modules 86
- Console interface card 46, 86
- Control Data 6
- Control Group 45, 52, 55, 66, 71, 79, 80, 81
 - On RCI and 6416m 72
 - Save/recall Preset 55
- Controller Connector 85
- Controller Input 67, 72, 75, 76, 81
- Controller Port 115, 118
- Control Master 11, 18, 20, 26, 43, 46, 65, 71, 101, 102
 - Assigning 21
 - Clock 21
 - DIP switch 21, 34
 - DIP switch 10 37
 - Password 102
 - Reset 106
 - Sample Alignment Lock 104
- Control Master DIP Switch 64
- Control Master Errors 34
- Control Master LED 20, 31, 41, 65
- Control signals 97
 - GPIO 61

- Convert Pro64 to Pro16 7
- Crossover Cable 127
- Crosstalk 111

D

- Data Bits 63
 - RS-232 63–65
- DB9
 - Null modem 107
 - pinout 126
- DB25 1, 124
 - Alternate In 58
 - As Aux Input 58
 - Strain relief 59, 125
- DB25 Audio Thru 33, 58
- DB25 connector thread 59, 125
- DB25 Pinout 58, 124
- DC Power 56, 68, 115
 - Backup 73
 - Pinout 112
 - RCI 73
- DC power supply
 - In-rush current, 6416m 112
- DC Requirements 56
- Deactivate a channel 47
- Deactivate a VDC 61
- Deactivate a VDC Slot 99
- Default password 101
- Default Settings 105
- Default value 103
- Digital Copies 88
 - Manual Mode 94
- Digital I/O 23, 24, 37
- Digital module 24
- Digital split 94
- Dimensions 113, 116, 119
- DIP switch 10, 27, 33
 - Baud Rates 64
 - Control Master 21, 34, 64–65, 106
 - GPIO 61–65
 - GPIO, RS-232 33
 - RS-232 21, 63–65
- DIP switch 10
 - Control Master 37
- Dot
 - No Control 80
- Dynamic Range 111

E

- Edit button 49, 54
- Edit Lock 28, 105

- Managed Mode 43
 - VDC query 44
- Edit Lock Button 31, 43
- Enter button 22, 31, 76, 81
- Enter/Cancel button 9, 11, 42
- Enter/Cancel LED 12, 22, 26
- Enumeration 21, 34, 86
- Equivalent Input Noise 111
- Error Recovery
 - Software Update 108
- EtherCon 1, 2, 9, 32, 57, 68, 74, 76
- Ethernet 5
 - Compatibility 89
- External Clock 24, 38. *See also* Clock

F

- Fiber 89
- Filter 50, 83
- Firmware Update 42, 100, 107
 - Error Recovery 108
- FOH 92
- FOH snake 18
- Frequency Response 111
- Front Panel Components 29
- Front panel lock 43
- Function
 - Clear A-Net Resources 100
 - Mute/Unmute all 100
 - Operating System Update 100
 - Password Lock/Unlock 100
 - Restore Factory Defaults 100
 - Set New Password 100
- Function 01 101
- Function 02 101
- Function 03 101
- Function 09 101
- Function 10 102
- Function 11 103, 105
- Function 12 104
- Function 13 104
- Function 14 105
- Function 15 107
- Function 16 105
- Function Button 29, 41, 100
- Function List 100
- Fuse 56
 - AC 73
- Fuse Holder 32, 68

G

- Gain 52

- Gain Control
 - MCS 77, 82
- Gain Display 52, 81
 - MCS 77
- Gain range 52
- Gain Range 111
- Gain settings 27
- Gain switches
 - Edit lock 43
- Gnome, lawn 34
- GPIO 61–65, 97, 98, 106, 112
 - Cable Length 123
 - DIP Switch 61–65
 - General Purpose I/O 6
 - isolated 122
 - Reset 106
 - Specifications 122
 - TTL 122
- GPIO Configuration DIP Switches 61
- GPIO DIP Switches 33
- GPIO Plugs 122
- GPIO Plug size 123
- GPIO Specifications 62
- GPIO Terminal Blocks 33
- Group 52, 71

H

- Headphone Monitor 115
- Headphone, RCI 66, 69
- High Resolution Meter 77, 84
- Hub
 - MH10 89

I

- IEC power cord 56, 73
- IEC Power Inlet 32, 68
- Inc/dec buttons 9, 35
 - A-Net Slot 14
- Inc/Dec Selection Buttons 78
- Input channel 46
- Input Impedance 111
- Inputs 86
- In-rush current 57
 - 6416m DC power supply 112
- Interface Conventions 9
- Internal Clock 24. *See also Clock*
- In Use LED
 - VDC 60, 98
- Isolated 106
 - GPIO 61, 122

J

- Jitter 5

K

- Keyhole
 - MCS 121
- Keypad 78

L

- Latency 5, 112
- Level Meter
 - Analog input 47
 - LEDs 29, 41, 47
- Level Meters
 - MCS 78
- Line-level input 83
- Line-Level Inputs 57
- Line-Level Output, RCI 68, 74
- Link button 47
- Lock front panel 43
- Lock the network 101
- Low Cut 50, 54
- Low Cut Button 77, 83
- Low Cut Filter 111

M

- Managed button 26, 27, 31, 43
- Managed Mode 26, 43, 101
 - Enter/exit 43
- Manual LED 36
- Manual Mode 6, 18, 20, 36, 40, 46, 47, 69, 90
 - Active channels 47
 - Available A-Net Slots 13, 19
- Master Clock 23, 24. *See also Clock*
- Max. Ambient Temp. 115
- Maximum Input Level 111
- m-control 1, 2, 50, 51, 52, 69
- MCS 47, 53, 55, 67, 71, 72
 - Save/recall Preset 55
 - Sync with RCI 71
- MCS Controller Connector 85
- MCS Front Pane 78
- MCS Front Panel Components 76
- MCS Mic Control Surface 45, 46, 52, 75
- MCS/RCI sync 71
- Merger Hub 89
- Meter 78, 84
- Meters

- 6416m 47
- MH10f 88, 89
- MH10 Merger Hub 88
- Mic pre Preset 48, 50, 52, 54, 79, 82
- MIDI 6, 33, 97, 112
 - Cable Length 123
- MIDI/GPIO Cable Lengths 123
- MIDI In 62
- MIDI In/Out 98
- MIDI Out 62
- Mode Selection 25
- Monitor 69
- Monitor Mixing System
 - Pro16 7
- Monitor Output 74, 115
- Monitor Volume Control 66
- Mounting, Rack 3
- Mounting the MCS 121
- Multipin
 - DB25 58
- Mute 54
- Mute all Channels 100, 101
- Mute Button 48, 77, 82
- Muted audio 34

N

- Network
 - Configuring 86
 - Network audio resource 12
- Network Mode 11, 18, 20, 26, 76, 78, 86
 - Auto/Manual 25
 - Defaults 105
- Network Mode, RCI 66, 69
- Neutrik EtherCon. *See EtherCon*
- No Control Indicator 76, 80
- Noise floor 111
- Null modem cable 27, 126
 - DB9 27, 107
- Numbered channel buttons
 - Password 102
- Numeric Keypad 76, 78

O

- Output Module 46, 94
 - AN-16/o 7
- Output Pad
 - RCI 68
- Output, RCI 68, 74

P

- Pad 54, 111
 - RCI 68
- Pad Button 50, 83
 - MCS 77
- Pad Switch
 - RCI 74
- Parity 63
- Passive split 58, 111
- Password 20, 100
 - Default 102
 - Edit Lock button 102
 - Reset 105
 - Set New Password 100, 102
- Password Lock 101
- Password protected 24
- Password Protection 27, 105
- Password Unlock 102
- PB28 Modular Patch Bay 124
- PC 107
 - Connecting, Managed Mode 27
 - Firmware update 107
- Peak Hold Button 77, 85
- Personal Mixer
 - A-16II, A-16R 7
- Phantom Power 51
 - MCS 84
- Phase 54
- Phase Button 49, 50, 77
 - MCS 82
- Pinout
 - DB25 58, 124
 - DC power 112
 - RS-232 126
- Plugs
 - GPIO 122
- Polarity 49
- Port 18
- Port A and B 36
- Port A, B 88, 90. *See A-Net Ports; See A-Net Port*
- Port assignments
 - VDC 44
- Port LED 36, 37
- Ports
 - A-Net 6
- Power On/Off Switch 32, 68, 73
- Power Requirements
 - DC, 6416m 56
- Power Supply 56, 73, 115
 - DC 57

- DC Backup 73
- Preset 51, 80, 83, 118
 - Save/recall 54
 - What gets saved 54
- Preset Rules 55
- Pro16 output device 48
- Pro16 Series 7
- Pro64 5
- Pro64 Modules 22
- Pro64 Network 86
- Pro64 Series 14
- Pro64 to Pro16
 - Convert 7
- Pro64 Update Tool 107, 108

Q

- Query Functions
 - A-Net Slot, VDC 44
 - Channel and VDC info 27
 - Edit Lock 43
 - In Managed Mode 43

R

- RCI 55, 90
 - Sync with MCS 71
- RCI and MCS sync 70
- RCI Front Panel Components 66
- RCI Output Pad 74
- RCI Rear Panel 73
- RCI Rear Panel Components 68
- RCI Remote Control
 - Manual Mode 91
- RCI Remote Control Interface 45, 46, 52, 85
- RCI Slot display 70
- RCI Specifications 115
- Rear support hardware 4
- Recall a Preset 55
- Recall Button 76, 80
- Redundant cable 91, 95
- remote control 90
- Remote control 52
- Restore Factory Defaults 100
- RJ45 2, 9, 57
- RoHS ii
- Routing 86
 - I/O hardware 14
- RS-232 6, 97, 98, 106, 107, 112, 126
 - And software update 107
 - DB9 63–65
 - Null modem cable 27, 107

- RS-232/422 33
 - And Managed Mode 43
- RS-232 Baud Rates 63–65, 107
- RS-232 DIP Switches 21, 33, 63–65
- RS-232 Port 62
- RS-422 6, 97

S

- Sample Alignment 103, 104, 105
- Sample Rate 5, 13, 19, 20, 24, 29, 37, 39, 41, 46, 105, 111
 - A-Net Slots 24
 - Available A-Net Slots 13
 - Changing 25, 38
 - Clock 21
 - Default 105
 - Minimum/maximum 5, 38
- Sample rate conversion 6
- Sample rate converter 37, 38
- Sample Rate LED 14, 25
- Save and Recall Buttons 76, 80
- Save a Preset 54
- Save/recall Preset
 - Control Group 55
- Select a Slot
 - From MCS 78
- Selecting Values 10
- Selection button 10
- Set New Password 100, 102
- Slave module 34
- Slot 6, 12, 14
 - Available 19
 - Base 35
 - Monitoring 69
 - Per Sample Rate 13
 - VDC 60
- Slot assignment 15
 - Channel 27
- Slot Configuration 29, 40
- Slot Display 76, 79
- Slot info 44
- Slot range 16, 35, 40
- Slot range display 13
- Slots 24
- Slot Selection 70
- Slots versus Channels 12
- Software update 72
- Specifications, 6416m 111
- Specifications, MCS 118
- Specifications, RCI 115
- Split 58, 88, 94
- Stage-to-FOH snake 18, 92

- Stereo Link 20
- Stereo Link Button 30, 47
- Stop bit 63
- Stored value 103, 104
- Strain relief
 - DB25 59
- Stranded vs. solid Cat-5 9
- Sync Indicator 66, 71
- Sync RCI and MCS 70
- System examples 87, 90, 91, 94, 96
- System-wide changes 22

T

- Tascam, DB25 124
- Tascam pinout 58, 124
- Temperature 112
- Terminal Blocks
 - GPIO 62
 - GPIO Specs 123
- THD +N 111
- Thread type
 - DB25 connector 59, 125
- Transmit 37, 40
- Transmit/Receive settings
 - A-Net 87
- Transporting in a rack 4
- TRS headphone jack 69
- TTL 106
 - GPIO 61, 122

U

- Unlock network 102
- Unmute all Channels 101
- Unshielded Twisted Pair 9
- Update
 - Operating System 100
- Update firmware 107
- Update Tool 107
- Up/down, inc/dec
 - Arrows 9
- UPS 3
- User Interface 11
- Using Peak Hold 85
- UTP cable 9, 72
 - Cat-5e, Cat-6 5

V

- VDC 42
 - Assign Port 97, 99
 - Clear 101

- deactivate 61
- DIP switches 21
- In Use 60
- In Use LED 98
- Query Functions 44
- Reset 106
 - RS-232 pinout 126
- VDC Configuration 31, 97
- VDC inputs 99
- VDC In Use LED 97, 98
- VDC outputs 99
- VDC Slot 11, 60, 97
 - Assigning 99
 - Selecting 98
 - Unassigning 99
- VDC Slot display 97
 - During software update 108
- Ventilation 4
- Virtual Data Cable Ports 33, 60
- Virtual Data Cables 6, 20, 112
- Volume Control 69
 - RCI headphone out 66

W

- Wander 5
- Wiring a Crossover Cable 127
- Wiring an Analog DB25 Cable 124
- Word Clock 6, 24, 37

X

- XLR 13, 58, 71
 - DC power 73
- XLR line-level inputs 57, 57–65
- XLR Output Level 115
- XLR output, RCI 68

Y

- Y1 card
 - Pro16 7
- Yamaha 1, 25, 39, 86, 92

Warranty Registration

Please take a moment to fill in this warranty registration form. Return it to Aviom via mail or fax. All information will be kept confidential.

Model Number _____ Product Serial Number _____

Model Number _____ Product Serial Number _____

Model Number _____ Product Serial Number _____

Model Number _____ Product Serial Number _____

Date Purchased _____

Dealer Name _____

Dealer Location _____

Your Name _____

Address _____

Address _____

City _____

State/Province _____

Zip/Postal Code _____

Country _____

Email Address . _____

Fax this form to Aviom at +1 610-738-9950

AVIOM[®]

1157 Phoenixville Pike, Suite 201 • West Chester, PA 19380
Voice: +1 610.738.9005 • Fax: +1 610.738.9950 • www.Aviom.com