

**System Telephones and Answering Machine**

**COMfortel® 1500**

**COMfortel® 2500**

**COMfortel® 2500 AB**

**COMfortel® Voicemail**

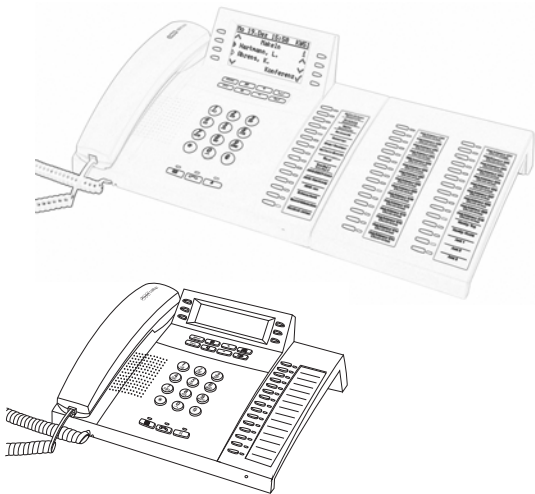

# Table of Contents

<b>Important Information</b> .....	17
Safety Information .....	18
Proper Use .....	19
Technical Data.....	21
Copyright.....	23
Environmental Notice .....	24
<b>Getting to Know Your Telephone</b> .....	25
Functions of Keys and LEDs .....	26
Menu Options.....	28
Menu Option Examples .....	28
Menu Overview.....	36
Icons .....	42
<b>Using the Configuration Software COMfortel Set</b> .....	49
Configuration Software COMfortel Set.....	50
Minimum Requirements for PC for Using Configuration Software COMfortel Set.....	50
Installing COMfortel Set.....	50
Starting COMfortel Set .....	51
Exiting COMfortel Set.....	51
Configuring the Language of the Configuration Software.....	52
Configuring Interface Used.....	52
Configuring V.24 options.....	53
Opening Configuration.....	54
Creating a New Configuration.....	55
Saving Configuration .....	56
Close the Configuration .....	57
Using Print Functions .....	57
Operating Instructions for COMfortel Set.....	59
Help.....	61
Opening the Help Topic-Relevantly.....	61
Navigating in the Help Window .....	61
Searching in the Help .....	64
Printing from within the Help.....	65
Icons in the Help Window .....	65

<b>Telephoning</b> .....	66
Incoming Calls .....	67
Options During an Incoming Call .....	67
Accepting Incoming Calls .....	68
Rejecting Incoming Calls .....	69
Hold incoming calls .....	69
Forwarding Incoming Calls .....	70
Call Waiting Calls .....	71
Options During a Call Waiting Call .....	71
Rejecting Call Waiting Calls .....	72
Accepting Call Waiting .....	72
Forwarding Call Waiting .....	73
Switching off Call Waiting Tone .....	74
Outgoing Calls .....	75
Options for Outgoing Calls .....	75
Picking up Receiver and Dialling Telephone Number .....	76
Dialling Telephone Number with Dial Preparation .....	76
Initiating External Calls with Number Presentation Suppression .....	77
Dialling Telephone Number on Direct Exchange Line Access .....	77
Options for Unsuccessful Calls .....	78
Initiating Callback on Busy .....	79
Initiating Callback on No Response .....	80
Initiating Priority Call for Do-Not-Disturb .....	81
Ending a Query Call .....	81
Calls .....	83
Options during a Call .....	83
Retrieving Information about a Call .....	84
Sending DTMF Signals .....	84
Muting a Call .....	84
Ending a Call .....	85
Query Calls .....	86
Initiating a Query Call .....	86
Options during a Query Call .....	87
Splitting .....	87
Ending One of the Two Calls .....	88
Connecting Both Communication Partners .....	88
Transfer .....	89
Options for Transferring a Call .....	89

Transfer with Announcement .....	90
Transfer without Announcement .....	90
Placing External Communication Partner in Waiting Loop .....	91
Calling a Third Subscriber and Transferring to an Active Communication Partner .....	92
Conference Calls .....	93
Initiating Conference Calls .....	93
Options during a Conference Call.....	93
Initiating Splitting during a Conference Call.....	94
Ending a Call with a Conference Call Partner .....	94
Connecting both Conference Call Partners .....	95
Ending Conference Call Completely .....	95
Hands-free Calling.....	96
Initiating Call in Hands-free Calling Mode .....	96
Ending up Call in Hands-free Calling Mode .....	96
Switching on Hands-free Calling During a Call.....	97
Switching off Hands-free Calling and Returning to Normal Calling .....	97
Loudspeaker Listening .....	98
Switching on Loudspeaker Listening during a Call .....	98
Switching off Loudspeaker Listening and Returning to Normal Calling.....	98
Ending a Call in Loudspeaker Listening Mode .....	99
Headset Calls .....	100
Initiating Headset Calls .....	100
Ending a Call in Headset Operation .....	100
Initiating Listen in Function on Receiver (only for COMfortel 2500) .....	101
Ending Listen in Function on Receiver (only for COMfortel 2500).....	101
<b>Telephone Book and Telephone Number Lists .....</b>	<b>102</b>
Telephone Book.....	103
Opening the Telephone Book .....	103
Dialling from Telephone Book.....	105
Configuring a Contact.....	106
Editing a Contact .....	109
Deleting a Contact .....	113
Entering Comments for a Contact .....	115
Configuring a Call Macro .....	116
Switching Specific Call Acceptance/Announcement for Telephone Book Contacts On/Off .....	118
Accepting Telephone Numbers from Dial Preparation.....	119

Accepting Telephone Numbers into Other Menus .....	120
Configuring Displayed Telephone Number Range for Telephone Book.....	121
Importing the Telephone Book.....	122
Importing Outlook Contacts .....	123
Exporting the Telephone Book .....	125
Redial List.....	127
Opening the Redial List .....	127
Dialling from Redial List.....	128
Deleting Entries in Redial List.....	129
Configuring Calls to be Recorded for Redial List.....	129
Calls List.....	131
Opening the Calls List .....	131
Dialling from Calls List .....	132
Deleting Entries in Calls List.....	133
Configuring and Operating Function Key for Calls List.....	133
Configuring Calls to be Recorded for Calls List.....	135
Caller List .....	137
Opening the Caller List .....	137
Dialling from Caller List.....	138
Deleting Entries in Caller List .....	139
Configuring and Operating Function Key for Caller Lists.....	140
Configuring Calls to be Recorded for Caller List.....	142
Configuring the LED Message Key.....	143
<b>Configuring and Operating Functions .....</b>	<b>145</b>
Automatic Call Acceptance .....	146
Switching Automatic Call Acceptance On/Off.....	146
Configuring and Operating Function Key for Automatic Call Acceptance.....	147
Attention Tone for Switching Automatic Call Acceptance On/Off.....	149
Configuring Call Acceptance Time for Automatic Call Acceptance .....	150
Boss/Secretary Function .....	152
Procedure when Calling the Boss Telephone.....	152
Switching Boss/Secretary Function on Boss Telephone On/Off.....	153
Configuring and Operating Secretary Key on Boss Telephone .....	153
Configuring and Operating Boss Key on Secretary Telephone .....	156
Switching Boss/Secretary Function for All Secretary Keys Off.....	159
Configuring and Operating Function Key for Switching Boss/Secretary Function Off .....	160

Call Deblocker (Incoming) – VIP Numbers .....	162
Switching Call Deblocker (Incoming) On/Off.....	162
Configuring and Operating Function Key for Call Deblocker (Incoming) .....	163
Call Forwarding .....	166
Call Forwarding Variations.....	166
Kinds of Call Forwarding.....	167
Switching Call Forwarding for Subscribers On/Off.....	168
Configuring and Operating Function Key for Call Forwarding for Subscribers .....	169
Switching Call Forwarding for External Numbers On/Off.....	177
Configuring and Operating Function Key for Call Forwarding for External Numbers.....	179
Call Restrictor (Incoming) – Robinson Numbers .....	189
Switching the Call Restrictor (Incoming) On/Off .....	189
Configuring and Operating Function Key for Call Restrictor (Incoming) .....	190
Call Waiting .....	193
Switching Call Waiting On/Off.....	193
Configuring and Operating Function Key for Call Waiting.....	194
Switching Call Waiting Signalling On/Off via LED/Tone.....	196
Configuration Switchover .....	198
Configuration Switchover Executed Manually.....	198
Configuring and Operating Function Key for Configuration Switchover.....	199
Do-not-disturb.....	203
Switching the Do-not-disturb Function On/Off .....	203
Configuring and Operating Function Key for Do-not-disturb.....	204
Configuring Type of Do-not-disturb.....	206
Door Functions .....	209
Executing Door Functions.....	209
Configuring and Operating Function Key for Door Functions .....	211
Exchange Line Transfer.....	216
Exchange Line Transfer Sequence .....	216
Configuring and Operating Function Key for Exchange Line Transfer .....	217
Follow me .....	219
Switching Follow me On/Off .....	219
Configuring and Operating Function Key for Follow me .....	220
Group Functions.....	223
Detailed Information about Group Functions .....	223
Logging the Telephone In/Out .....	224
Logging Telephone Out of All Groups.....	225

Configuring and Operating Function Key for Group Function.....	225
Configuring and Operating Function Key for Logging Out of All Groups .....	230
Configuring and Operating the Display of the Group Status.....	232
Hotel Function .....	235
Function Areas of the Hotel Function .....	235
Configuring the Hotel Function .....	236
Check/Change Room Status on Hotel Reception Telephone .....	238
Performing Check-in on Hotel Reception Telephone .....	239
Configuring Wake-up Time for Room on Hotel Reception Telephone .....	239
Querying Call Charges for Room on Hotel Reception Telephone .....	240
Printing Interim Invoice for Room from Hotel Reception Telephone .....	241
Blocking External Telephoning for Room on Hotel Reception Telephone.....	242
Performing Check-out on Hotel Reception Telephone.....	242
Configuring Wake-up Time on Hotel Room Telephone .....	245
Querying Call Charges on Hotel Room Telephone.....	245
Configuring and Operating Function Key for Hotel Room on Hotel Reception Telephone .....	246
Configuring and Operating Function Key for Hotel Room on Hotel Room Telephone .....	248
InterCom Announcement/Handsfree.....	251
InterCom Announcement Procedure .....	251
Executing InterCom Announcement.....	252
Configuring and Operating Function Key for InterCom Announcement.....	252
InterCom Handsfree Procedure.....	256
Executing InterCom Handsfree.....	256
Configuring and Operating Function Key for InterCom Handsfree .....	257
Switching InterCom Permission On/Off .....	259
Configuring and Operating Function Key for InterCom Permission .....	260
Loudspeaker Audio Out.....	263
Executing Loudspeaker Audio Out .....	263
Configuring and Operating Function Key for Loudspeaker Audio Out .....	264
Macro .....	267
Macro Execution Procedure .....	267
Configuring and Operating Function Key for Macro.....	268
Configuring Display Presentation during Macro Execution.....	271
Memo .....	273
Creating a Memo .....	273
Retrieving a Memo.....	274

Phone Lock .....	275
Enabling the Phone Lock.....	275
Disabling the Phone Lock .....	275
Configuring and Operating Function Key for Phone Lock.....	276
Pickup.....	279
Executing Pickup .....	279
Executing Pickup during Call .....	279
Configuring and Operating Function Key for Pickup.....	280
Power Dialling.....	283
Power Dialling Procedure .....	283
Executing Power Dialling .....	283
Cancelling Power Dialling .....	284
Switching Attention Tone for Power Dialling On/Off .....	284
Power Save Mode .....	286
Switching Automatic Activation of Power Save Mode On/Off .....	286
Switching Power Save Mode Activation On/Off Depending on Configuration .....	287
Configuring and Operating Function Key for Manually Activating Power Save Mode.....	289
Switching the Power Save Mode Link to Phone Lock On/Off .....	290
Project Assignment .....	292
Detailed Information about Project Assignment.....	292
Initiating a Project Assignment .....	292
Executing Project Assignment during a Call.....	293
Configuring and Operating Function Key for Project Assignment.....	294
Configuring a List for Project Assignment .....	298
Exporting a Project List.....	298
Importing a Project List .....	299
Relays .....	301
Switching Relays On/Off.....	301
Configuring and Operating Function Key for Switching Relays On/Off.....	302
Room Monitoring.....	305
Initiating Room Monitoring .....	305
Ending Room Monitoring .....	305
Configuring and Operating Function Key for Room Monitoring .....	306
Scheduled Call .....	308
Opening Scheduled Call List .....	308
Configuring Scheduled Call as Schedule Reminder.....	309
Configuring Scheduled Call as Call Reminder .....	310
Accepting Scheduled Call as Schedule Reminder .....	311



Accepting Scheduled Call as Call Reminder .....	312
Editing Existing Scheduled Calls in Scheduled Call List .....	312
Deleting Existing Scheduled Calls from Scheduled Call List.....	313
Configuring and Operating Function Key for Scheduled Calls.....	313
Speed Dialling .....	316
Application Options for Speed Dialling Keys.....	316
Configuring and Operating Function Key for Speed Dialling .....	317
Switching Automatic Speed Dialling Pick-up On/Off.....	320
Switching the Display of the Registration Status On/Off.....	321
Targeted Exchange Line Access .....	323
Targeted Exchange Line Access Variants .....	323
Initiating Targeted Exchange Line Access .....	324
Configuring and Operating Function Key for Targeted Exchange Line Access (A) .....	324
Configuring and Operating Function Key for Targeted Exchange Line Access (B) .....	327
Configuring and Operating Function Key for Targeted Exchange Line Access (C) .....	329
Targeted VoIP Access Point .....	333
Initiating a Targeted VoIP Access Point .....	333
Configuring and Operating Function Key for Targeted VoIP Access Point .....	334
Text before Answering .....	337
Variants for Text before Answering .....	337
Switching Text before Answering for Group On/Off .....	338
Configuring and Operating Function Key for Text before Answering for Group .....	338
Switching Text before Answering for External Telephone Number On/Off.....	341
Configuring and Operating Function Key for Text before Answering for External Telephone Number .....	341
Voicemail Center 461/461.2 .....	345
Initiating Remote Access to Voicemail Center .....	345
Configuring and Operating Function Key for Remotely Accessing the Voicemail Center.....	345
Switching Rapid Remote Access of Voicemail Centers 461.2 On/Off .....	351
Waiting Field Function .....	353
Configuring a Waiting Field .....	353
Sequence for Call Acceptance in Waiting Field.....	355
Switching Waiting Field Reception On/Off.....	356
Configuring and Operating Function Key and External Waiting Field.....	357
Configuring and Operating Function Key for Internal Waiting Field.....	360
Configuring and Operating Function Key for Switching Waiting Field Reception On/Off .....	363

Switching Attention Tone for Waiting Field On/Off .....	366
<b>Configuring and Operating the Answering Machine .....</b>	<b>367</b>
Forwarding Incoming Calls to Answering Machine.....	368
Answering Machine Accepts Call – Call Acceptance .....	369
Readiness .....	370
Switching Readiness On/Off.....	370
Configuring and Operating Function Key for Readiness.....	371
Answering Machine List .....	374
Opening the Answering Machine List .....	374
Listening to recordings (messages and call recordings) .....	376
Dialling from the Answering Machine List .....	377
Configuring the LED Message Key .....	377
Configuring and Operating Function Key for Answering Machine List.....	377
List of Voice Memos .....	380
Recording Memos .....	380
Configuring and Operating Function Key Recording Voice Memos.....	381
Opening the List of Voice Memos .....	382
Listening to Recordings (Memos) .....	384
Configuring the LED Message Key.....	384
Announcements .....	385
Creating a New Announcement.....	385
Editing Existing Announcement in List .....	386
Deleting an Existing Announcement from List.....	387
Configuring and Operating Function Key for Editing Announcements.....	388
Call Acceptance and Announcement Assign-ment .....	391
Configuration Variants for Call Acceptance and Announcement Assignment .....	391
Call Types .....	392
Configuring Simple Automatic .....	393
Configuring Automatic for Experts.....	395
Creating Entries for Automatic.....	397
Deleting Entries in Automatic.....	407
Configuring and Operating Function Key for Manually Activating Entries in Automatic...	408
Switching Time Control On/Off .....	411
Configuring and Operating Function Key for Time Control.....	412
Basic Settings.....	415
Configuring Call Acceptance Time .....	415
Configuring Maximum Recording Time .....	416

Configuring Maximum Recording Time for Door Terminal Calls.....	418
Switching Listen in Function On/Off .....	419
Switching Automatic Playback On/Off .....	420
Call Recording.....	422
Executing Call Recording .....	422
Configuring and Operating Function Key for Call Recording Initiation On/Off .....	423
Switching Automatic Call Recording On/Off .....	425
Configuring and Operating Function Key for Automatic Call Recording .....	426
Switching Info Tone for Call Recording On/Off .....	428
Remote Access .....	430
Remote Access Variants .....	430
Configuring Remote Access .....	431
Switching Remote Access On/Off .....	432
Switching Remote Access Toll Saver (and Quick Access) On/Off.....	433
Entering Quick Access Telephone Numbers .....	434
Executing Remote Access.....	436
Message Forwarding.....	438
Message Forwarding Sequence .....	438
Switching Message Forwarding On/Off .....	438
Configuring and Operating Function Key for Message Forwarding .....	440
Configuring Announcement for Message Forwarding.....	442
Configuring a Message Forwarding Target.....	443
Configuring Waiting Period for Message Forwarding.....	445
Configuring Message Forwarding Repetition.....	446
Data Exchange.....	448
Transferring Data from PC to SD Card .....	448
Transferring Data from SD Card to PC .....	449
Delete Data from SD Card/PC.....	451
Selecting Another Telephone for Data Exchange .....	452
Saving Standard Announcements on Telephone.....	453
<b>Configuring and Managing the Telephone.....</b>	<b>454</b>
Identification .....	455
Configuring MSN .....	455
Protection from Unauthorised Access.....	457
Configuring User PIN.....	457
Configuring a Function Lock.....	458
Configuring Settings Lock.....	460

Display and Backlight .....	463
Configuring the Language on Telephone.....	463
Configuring Display Backlight (only for COMfortel 2500) .....	463
Configuring Brightness (only for COMfortel 2500).....	465
Adjusting Contrast .....	466
Switching the Inverse Display View On/Off (only for COMfortel 2500) .....	466
Configuring Time Format.....	467
Configuring Date Format .....	468
Call Signalling.....	470
Switching Ring Signal On/Off .....	470
Configuring and Operating Function Key for Ring Signal .....	471
Switching Flashing Display Backlight for Call Signalling On/Off (only for COMfortel 2500) .....	473
Configuring and Operating Function Key for Call Signalling by Flashing Display Backlight (only for COMfortel 2500).....	474
Ringer Melodies .....	478
Determining Different Types of Calls .....	478
Configuring Ringer Melodies .....	480
Changing Volume Automatically .....	482
Call Charges.....	484
Configuring Currency.....	484
Configuring Cost per Call Unit.....	484
Receiver and Headset.....	486
Adjusting Receiver Volume .....	486
Switching Headset Operation On/Off.....	486
Configuring and Operating Function Key for Headset Operation .....	487
Configuring Headset Type .....	489
Switching Headset Ringing On/Off .....	490
Adjusting Headset Volume.....	491
Menu and Function Keys.....	492
Restricting Menu Selection .....	492
Configuring Accessibility of Second Key Level .....	492
Configuring and Operating Function Key for Shift .....	494
Exchanging or Moving Function Keys.....	496
<b>Configuring and Managing Voice Mailboxes .....</b>	<b>497</b>

Voice Mailbox .....	498
Opening a Voice Mailbox.....	499
Listening to Recordings .....	501
Selecting from the Message List of the Voice Mailbox .....	502
Configuring and Operating the Function Key to Open the Voice Mailbox.....	502
Readiness .....	507
Switching Readiness On/Off.....	507
Configuring and Operating the Function Key for Readiness.....	508
Configuration-Dependent Control.....	512
Switching the Configuration-Dependent Control On/Off.....	512
Configuring and Operating the Function Key for Configuration-Dependent Control.....	513
Voice Memos.....	517
Configuring and Operating the Function Key for Recording Voice Memos.....	517
Distribution of Messages .....	520
Configuring and Operating the Function Key for Distributing Messages .....	520
Announcements .....	524
Create a New Announcement.....	524
Edit an Existing Announcement.....	525
Delete an Existing Announcement .....	526
Switching the Call Information On/Off for New Messages .....	527
Switching the Separator Tone On/Off for New Messages.....	527
Remote Access .....	529
Execute Remote Access.....	529
Switching Remote Access On/Off .....	530
Configuring and Operating the Function Key for Remote Access .....	531
Message Forwarding.....	535
Switching Message Forwarding On/Off .....	535
Configuring and Operating the Function Key for Message Forwarding .....	536
Substitute Function.....	540
Switching the Substitute Function On/Off.....	540
Configuring and Operating the Function Key for the Substitute Function.....	541
<b>Service and Maintenance .....</b>	<b>546</b>
Firmware Update.....	547
Firmware Update Variants .....	547
Initiating Manual Firmware Update.....	547
Configuring Update Server Number .....	549

Initiating Instant Firmware Update via Update Server .....	549
Distributing Firmware.....	550
Saving Firmware as File on PC .....	551
Data Backup.....	552
Data Backup on PC .....	552
Data Backup to SD Card .....	555
Selecting a PBX .....	558
Initiating PBX Synchronisation .....	559
Deleting Data.....	560
Restoring Factory Setting .....	560
Deleting Charges .....	561
Deleting Personal Data.....	561
Diagnostic Functions .....	563
Performing Line Check (BERT) .....	563
Determining the services on the PBX.....	564
Checking Quality of SD Card (COMfortel 2500 Only).....	564
<b>Glossary</b> .....	565
Terminology and Functions .....	566
A .....	566
B .....	566
C .....	567
D .....	569
E .....	570
F .....	570
G .....	571
H .....	571
I.....	572
L.....	572
M.....	573
P .....	574
Q .....	575
R .....	576
S .....	577
T .....	577
V .....	579
W .....	579

Abbreviations.....	580
<b>Index</b> .....	<b>581</b>





# Important Information

This section includes necessary information for operating your equipment safely. Before you put the telephone into operation, it is absolutely necessary for you to read the safety information described here and to make yourself familiar with the intended use of the device as well as the technical information.

## Topics

- [Safety Information \(page 18\)](#)
- [Proper Use \(page 19\)](#)
- [Technical Data \(page 21\)](#)
- [Copyright \(page 23\)](#)
- [Environmental Notice \(page 24\)](#)

## Safety Information

Please observe the basic safety information given in the following.



**Warning:** Improper use or replacement of the wall-mounted power supply can cause a life-threatening electric shock or may damage or destroy the device:

- Therefore, when using the COMfortel Xtension30 key extension modules (not included in the package), only use the wall-mounted COMfortel XT-PS power supply type No. 809.
- Make sure the plug is inserted securely into the wall mains outlet. Loose plugs or damaged outlets are a fire hazard.
- Do not pull on the cable of the wall-mounted power supply. Carefully pull the wall-mounted power supply out of the socket if you want to switch off device power.
- If the wall-mounted power supply becomes damaged: Cut off the mains power in the house first before pulling the plug out of the wall-mounted power supply.
- Be sure to follow the applicable regulations when handling 230 V system voltage and devices attached to the mains.

**Warning:** Touching a defective connection cable may cause a life-threatening electric shock. Also any damage to the casing or to the device itself may be hazardous to life and limb.

- Only insert the plugs into the appropriate wall outlets.
- Replace damaged connection lines immediately.
- Repairs should be carried out immediately and only by an expert. Contact your authorized dealer or the manufacturer directly.
- Use original components only.
- Do not touch the plug contacts with sharp, metallic or moist objects.
- The device should not be carried by the cables.
- Use the cable channels available on the back of the telephone to reduce strain when carrying the device.

**Warning:** Liquids entering the casing can cause life-threatening electric shocks or damage/destroy the device.

- Select the installation location carefully and when cleaning the casing to prevent liquids from entering the casing.
- The telephone must not be used in wet environments (for example, bath rooms).

## Proper Use

---

**Important:** Auerswald products are not designed, manufactured or intended for use or resale in environments requiring fail-safe performance, such as in the operation of life-support systems and/or nuclear facilities. Use or sale of our products for these purposes is only allowed with prior written permission by Auerswald for each individual incident.

---

---

**important:**

Improper use may cause, e.g. functional restrictions or interference, the destruction of the device or, in a worst case scenario, personal injury.

If you are still not sure of the intended use of the product after reading the following section, please contact your vendor.

---

The COMfortel 1500 and COMfortel 2500 are system telephones.

System telephones are intended exclusively for connecting to an internal S0 or UP0 port of the following PBXs from Auerswald: COMpact 2204 USB, COMpact 3000, COMpact 2206 USB, COMpact 4406 DSL, COMpact 4410 USB, COMpact 5010 VoIP, COMpact 5020 VoIP, COMmander Basic (19"), COMmander Basic.2 (19") and COMmander Business (19").

---

**Note:**

For this purpose, some of the PBXs mentioned above have to be equipped with a suitable module.

Connecting to a PBX from another manufacturer or to the external S0 connection of a network provider is not intended.

---

System telephones are not cordless and are intended for use in closed, dry rooms.

System telephones are different from "normal telephones" connected to PBXs in that they are especially easy to use. Most of the functions available on the PBXs such as internal and external calls, Do-not-Disturb and call forwarding can be operated over the display or by simply pressing previously programmed buttons. In addition, the PBX system telephones support offered functions for telephone switch boards (for example, the Waiting Field) and various telephone number lists (for example, the telephone book or call list).

System telephones can be configured using not only the menu displayed on the device but also using the computer software included in the package. The computer required for this is either connected directly to the telephone USB port (only for the COMfortel 2500) or to a computer port on the PBX.

System telephones make it possible to make calls not only using the connected receiver but also via the integrated loudspeakers (hands-free calling). Another option is to connect a headset (not included in the package).

The COMfortel 2500 supports the operation of cable-connected headsets as well as wireless headsets (headsets with a DHSG interface, e.g. from GN or Plantronics). The COMfortel 1500 supports the operation of cable-connected headsets. The connection to the COMfortel 1500 is made to the receiver jack instead of to the receiver.

With up to three COMfortel Xtension30 key extension modules (not included in the package) the COMfortel 2500 can be extended by freely programmable function keys. The modules can be connected on the left or right of the telephone at your choice. A fully extended telephone has 105 freely programmable function keys available.

The COMfortel Voicemail software function (not included in the package; fee-based activation at the Upgrade Center) and a commercially-available SD or SDHC card (not included in the package) let you add an answering machine to the COMfortel 2500.

---

**Note:**

In the COMfortel 2500 AB (special COMfortel 2500 model), the COMfortel Voicemail function and the SD card required for it are included in the factory settings.

Accessory and service components are available at your authorized dealer or in the Internet shop distriCOM at <http://www.districtcom.de>. (Shipping only available in Germany and to Austria.)

---

## Technical Data

### Technical Data of the telephone

Operating voltage	Voltage via internal S <sub>0</sub> port or U <sub>P0</sub> port through the PBX; COMfortel 2500 with COMfortel Xtension30: Voltage via wall-mounted power supply is necessary; 230 V M; W10%; 50 Hz
Wall-mounted power supply	COMfortel XT-PS; type number 809
Power consumption	COMfortel 1500: min. 0,5 W, max. 2 W COMfortel 2500: min. 0,6 W, max. 2 W (without COMfortel Xtension30 key extension modules)
System connection	Internal S <sub>0</sub> port or U <sub>P0</sub> port of one of the following PBXs: COMmander Business (19"), COMmander Basic.2 (19"), COMmander Basic (19"), COMpact 5020 VoIP, COMpact 5010 VoIP, COMpact 4410 USB, COMpact 4406 DSL, COMpact 2206 USB, COMpact 3000 or COMpact 2204 USB
Computer/data interface	COMfortel 1500: none COMfortel 2500: USB
Displays	18 LEDs, some multi-coloured COMfortel 1500: LCD, 128 x 32 pixels COMfortel 2500: LCD, 128 x 64 pixels, white backlight COMfortel Xtension30: 30 LEDs, multi-coloured
User elements	COMfortel 1500: keypad, 11 function keys, 6 softkeys, 15 programmable function keys COMfortel 2500: keypad, 11 function keys, 8 softkeys, 15 programmable function keys COMfortel Xtension30: 30 programmable function keys
Handset	Electret microphone, dynamic receiver, hearing aid compatible
Loudspeaker	8 Ohm, Ø 66 mm
Hook switch	Magnetic switch contact
Casing	Plastic material
Colours	White (light grey), dark blue, black
Dimensions (W x D x H)	COMfortel 1500: 261 mm x 216 mm x 89 mm COMfortel 2500: 261 mm x 216 mm x 109 mm COMfortel Xtension30: 146 mm x 216 mm x 55 mm
Weight	COMfortel 1500: ca. 980 g COMfortel 2500: ca. 1120 g COMfortel Xtension30: ca. 410 g
Temperature range	0 to 40 °C
Safety	CE

### Technical Data for Connecting a Headset

Current microphone consumption	Max. 0,5 mA
Microphone sensitivity	45 dB
Loudspeaker impedance	150 Ohm
Loudspeaker sensitivity at 1 kHz	19,5 W3 dBP <sub>a</sub> /V
Sound pressure limit	24 dBP <sub>a</sub>

### Receiver jack pinout (COMfortel 1500)

1	Microphone +
2	Loudspeaker +
3	Loudspeaker -
4	Microphone -

### Headset jack pinout (COMfortel 2500)

1	DHSG BUS_IN
2	DHSG GND
3	Microphone -
4	Loudspeaker -
5	Loudspeaker +
6	Microphone +
7	DHSG + 3.3 V
8	DHSG BUS_OUT

# Copyright

Disseminating and reproducing these instructions, as well as using and disclosing the contents, even in part, is permitted only with our express permission. Offenders will be subject to claims for damages. All rights reserved. f Auerswald GmbH & Co. KG, 38162 Cremlingen, 2010

## Environmental Notice

If your Auerswald device is taken out of use, please make sure that it is properly disposed of (must not be disposed of with normal household waste).



For the sake of environmental protection, please make sure that packaging materials are also properly disposed of.



Please consult your municipal administration authorities for options of proper and environmentally safe disposal of the device. If you want us to take over the disposal, please send the device to us. Shipment which is not prepaid cannot be accepted.



Batteries and accumulators have to be discharged completely before disposal (empty/voltage-free). Batteries have to be handed in at the collection point for old batteries.



# Getting to Know Your Telephone

This section provides a general overview how to operate the telephone. Here, you will find a description of the icons and text shown on the unit display as well as the keys on the device. In addition, you get an overview of the contents of the individual menus.

## Topics

- [Functions of Keys and LEDs \(page 26\)](#)
- [Menu Options \(page 28\)](#)

## Functions of Keys and LEDs

The keys and the functions that are executed by them are listed at the end:

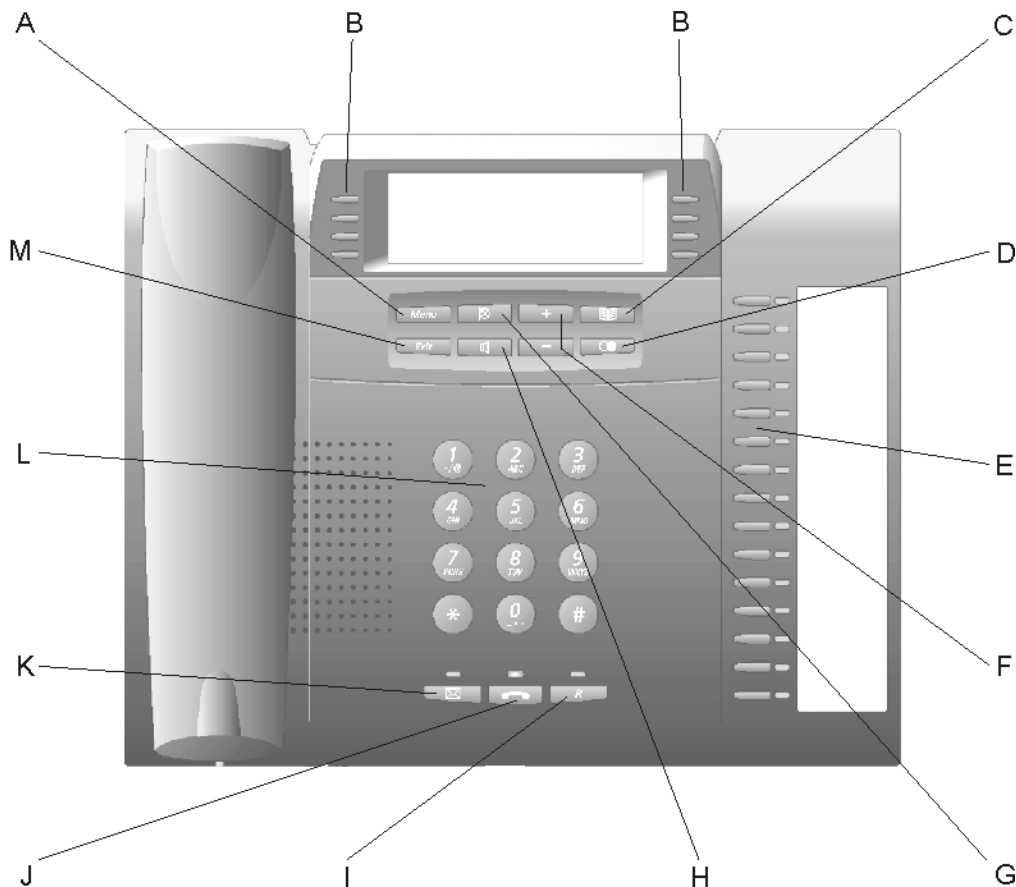

- A Menu key  
Opens the main menu.
- B Softkeys  
Switch their function depending on the situation.
- C Telephone book key  
Opens the telephone book
- D Redial key  
Opens the redial list.  
Scrolls through the redial list.  
When the receiver is off the hook, dials the previously dialled telephone number.
- E Function keys with LED  
They are freely programmable.  
The LED indicates the status depending on the key definition.
- F Plus/minus key  
Increases/decreases the volume of the ringer, the receiver or loudspeaker depending on the operating mode.

- G Microphone key  
Switches the microphone off (mute) and on again.
- H Loudspeaker key  
Switches loudspeaker listening on during a call.  
Holding the key (for 2 seconds) switches hands-free calling on.
- I Query key with LED  
Initiates a query call.
- J Hook key with LED  
Initiates/Ends headset calls or calls in hands-free calling mode.  
The LED signals incoming calls
- K Message key with LED  
Opens the caller list, the answering machine list and the list of voice memos.  
The LED signals existing (new) entries.
- L Keypad  
Enables number dialling as well as entering digits and letters.
- M Exit key  
Closes the opened menu. Incorrectly exited settings are not saved.

## Menu Options

The COMfortel 2500 has a 5-line graphic display, and the COMfortel 1500 has a 3-line display; each line has 16 characters (when entering telephone numbers, the font size is changed to display more characters).

On both sides, there is room for up to four (COMfortel 2500) or three (COMfortel 1500) icons that show the functions of the softkeys next to them. These special keys next to the display change their function depending on the situation and facilitate operation.

---

**Note:** In the second menu/function level (after pressing the **softkey**  $\Phi 2$ ), icons are not used. The function is named in clear text next to the corresponding key. Some softkeys are not used in the information menu in order to display more information.

---

The appearance of the display depends on the state of the telephone.

Only those functions are offered that are usable in the respective state. If not all of the information can be displayed due to lack of space (this affects the COMfortel 1500 especially), only the most important functions are displayed.

---

### Menu Option Examples

The menu options are dependent on the state of the telephone. In conclusion, here are several examples of menu options.

#### Menu Options in the Idle State

The following information is shown on the display while the telephone is in the idle state:

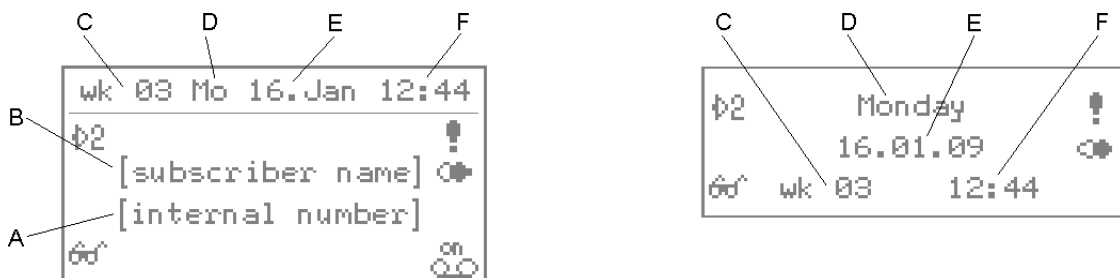

A The internal telephone number of the subscriber in the PBX

- B Name of the subscriber in the PBX
- C Calendar week
- D Weekday
- E Date
- F Time

In addition, various pieces of status information are displayed:

- Current settings that affect telephoning, for example, call allowance account empty, baby/senior calls
- Current settings that limit reachability, for example, do-not-disturb, call forwarding immediately, follow-me, ringer off
- No connection to the PBX
- Missed scheduled call
- Power dialling enabled

Press the **☰ softkey** to switch to the menu/function level 2.

```
second level
-----
calls list      pickup
project
Voicemail      schedule
```

```
calls list      pickup
project
Voicemail      schedule
```

Press the **softkey** to perform various functions. The current function of the **softkey** is displayed in the second level by the text to the side.

### **Menu Options in Main Menu (after Pressing Menu Key)**

Press the **☰ menu key** to open the main menu with various menus.

```
menu
-----
☰ selection
▶ funktions      ^
▶ information    v
▶ define keys
```

```
☰ menu      ^
▶ funktions v
▶ information
```

Press the **▼** and **▲ softkeys** to scroll through the selection list.

Press the **▶ softkey** to go to the next menu labelled in the text.

- In the **Functions** menu, you can activate/deactivate or execute functions in the PBX and the telephone (for example, call forwarding and the telephone lock).

- The **Information** menu is only used to display information (for example, versions, accumulated charges and the status of certain important functions/settings). No changes can be made here.
- In the **define keys** menu, you can assign functions on the PBX and the telephone to programmable function keys (for example, call forwarding and speed dialling).
- In the **settings** menu, you can configure the telephone.
- In the **answer.machine** menu, you can configure and operate the answering machine.
- In the **diagnosis** menu, you can perform diagnostic functions.

In the submenus, you can scroll through the selection lists using the **▼** and **▲** **softkeys** just as you can in the main menu. Press the **▶** **softkey** to again go to the next menu labelled in the text.

To go back to the preceding menu level, press the **⏪** **softkey**. To go back into the idle state, press the **exit key**. In addition, the telephone automatically switches back into the idle state if no keys are pressed within a period of 30 seconds.

---

#### **Important:**

Some functions are not offered until the function is available on the PBX and has been configured, and if necessary, an authority level has been granted for the use of this function.

The functions and settings available in the menus **functions**, **define keys**, **settings** and **answer.machine** can be restricted by the administrator to prevent unauthorised use. The release and display of these disabled functions in to the selection list requires entering the corresponding PIN after selecting **additional**. The release remains intact during the settings that now follow. The release is revoked if no keys are pressed within a time period of 60 seconds. You can actively disable the release by selecting **log out** in the menu **settings > blocking > additional**.

---

#### **Menu Options during Key Definition**

Press the **menu key** and then press the **▶** **softkey** in front of **define keys** to open the associated menu.

After this, you must first press the **function key** to be defined and then the **▶** **softkey** in front of the level to be defined.

If the function key has not yet been defined with a function, you can select the desired function after selecting the level to be defined.

On the other hand, if the function key has already been defined with a function, the selection of the level is then followed by a selection menu for further procedures. Select **new** to select a new function for the key in question. Select **delete** to empty the key of any definitions. Keys that have been defined with functions are redefined by selecting **change** (for example, a new telephone number for call forwarding). If you have made a mistake and would like keep the original state, press the **softkey**.

### Menu Options in Telephone Number and Text Entry Menus

To enter a telephone number or text, the telephone opens one of the following menus.

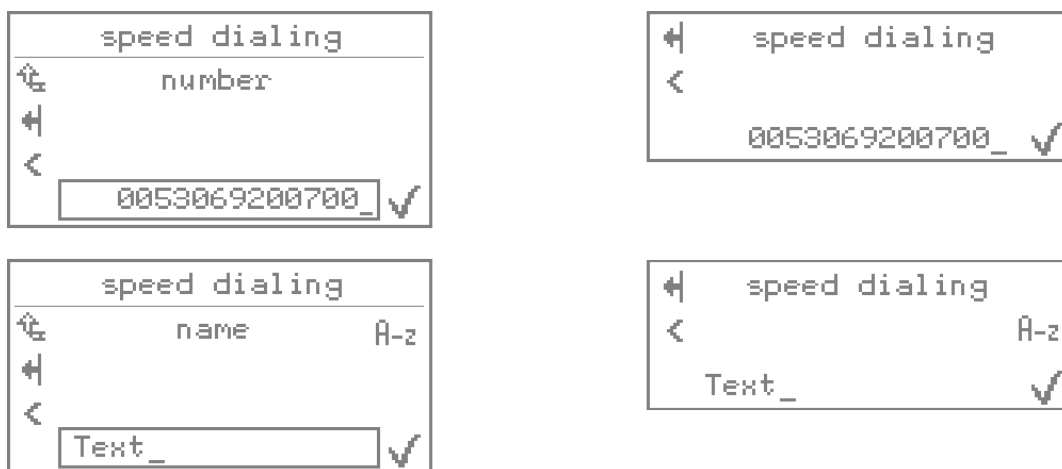

Using the **pushbutton dial**, you can enter the digits, characters and letters you need. In the text entry menu, press the **digit keys** want a more times until the desired character appears. The assignment is listed in the table at the end.

Press the **softkeys** **A-Z**, **A-Z** and **a-z** to switch between uppercase and lowercase letters. The icon indicates the current settings.

If you would like to make changes to your entry, move the cursor to the left and right by pressing the **<** and **>** **softkeys**. Press the **⌫** **softkey** to delete the last character before the cursor.

Press the **✓** **softkey** to accept the entry.

Key	Assignment for uppercase letters	Assignment for lowercase letters
1	1 - / @ +	1 - / @ +
2	A B C 2 Ä Æ Å Ç	a b c 2 ä æ å à â ç
3	D E F 3 É	d e f 3 é è ê ë
4	G H I 4	g h i 4 ì í î ï
5	J K L 5	j k l 5
6	M N O 6 Ö Ø	m n o 6 ö ø ñ ó ò ô

Key	Assignment for uppercase letters	Assignment for lowercase letters
7	P Q R S 7 ß	p q r s 7 ß
8	T U V 8 Ü	t u v 8 ü ú ù û ý
9	W X Y Z 9	w x y z 9
0	Space 0. , : ' " ? ¿ ! ¡ _	Space 0. , : ' " ? ¿ ! ¡ _
*	* ( ) [ ] < = > « » ^ ' ~ { }	* ( ) [ ] < = > « » ^ ' ~ { }
#	# % & § £ \$ Euro symbol	# % & § £ \$ Euro symbol

### Menu Options During Incoming Calls

The following information is displayed during an incoming call:

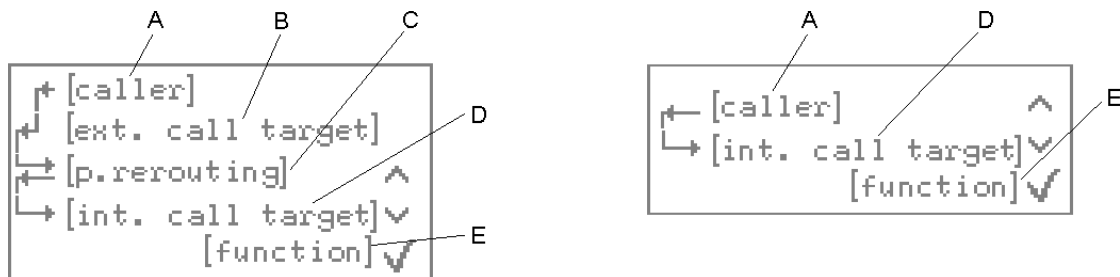

A Caller, call waiting or call type (for special calls, for example, alarm calls, wake-up calls)

---

#### **Note:**

If the telephone number is entered in the telephone book of your system telephone or in the central telephone book (short-code numbers) on the PBX, as soon as the telephone detects the telephone number, it will show the associated name in the display instead of the telephone number. The prerequisite for displaying the telephone number is that the exchange line subscriber has not suppressed the display of his telephone number or that he has approved transmission of the telephone number.

If the telephone number is not available, "Unknown" is displayed.

If the name of the caller is not in the telephone book, a search for the name can be performed using the online name search function on a server in the Internet (see the PBX manual). If the telephone number is transmitted for an incoming call, the PBX automatically looks for the corresponding entry. When an entry is found, it is shown on the display of the system telephone.

---

B External call target/exchange line number called (for external calls), doorbells (for door calls) or InterCom type (for InterCom calls)



- C The person rerouting the call (for rerouted calls)

---

**Important:** Only available for operation on the PBXs COMpact 3000, COMpact 5010 VoIP, COMpact 5020 VoIP, COMmander Basic.2 and COMmander Business.

---

- D Internal call target (subscriber or group)
- E Possible Functions for Incoming Calls

Your system telephone shows possible functions during an incoming call in the lower line of the display. Press the  $\nabla$  and  $\blacktriangle$  **softkeys** to scroll through the various options. Press the  $\checkmark$  **softkey** to initiate the function currently displayed.

### Menu Options during Outgoing Calls

The following information is displayed during an outgoing call:

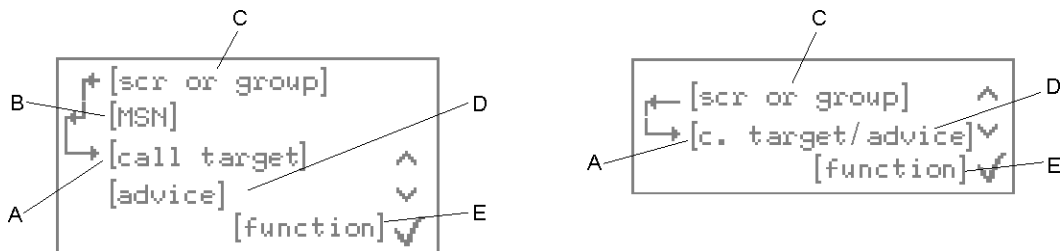

- A Call target

---

#### **Note:**

If the telephone number dialled has been assigned a name in the telephone book of the system telephone, this will be displayed as soon as the telephone detects the telephone number. The telephone number is simply overwritten by the name.

If less than nine digits have been entered, they are displayed in a larger font to facilitate legibility (during dialling/during the call). If the telephone number dialled has been assigned a name in the telephone book of the system telephone, and this name comprises fewer than nine characters, this name is also displayed in a larger font.

---

- B Outbound MSN used for the call

---

**Important:** Only available for operation on the PBXs COMcompact 3000, COMcompact 5010 VoIP, COMcompact 5020 VoIP, COMmander Basic.2 and COMmander Business.

---

- C Subscriber or group (if "logged in as outgoing" in a group)
- D Note (for example, busy, do-not-disturb, no exchange line authorisation)
- E Possible Functions for Outgoing Calls

Your system telephone shows possible functions during an outgoing call in the lower line of the display. Press the  $\nabla$  and  $\blacktriangle$  **softkeys** to scroll through the various options. Press the  $\checkmark$  **softkey** to initiate the function currently displayed.

### Menu Options during Calls

The following information is displayed during a call:

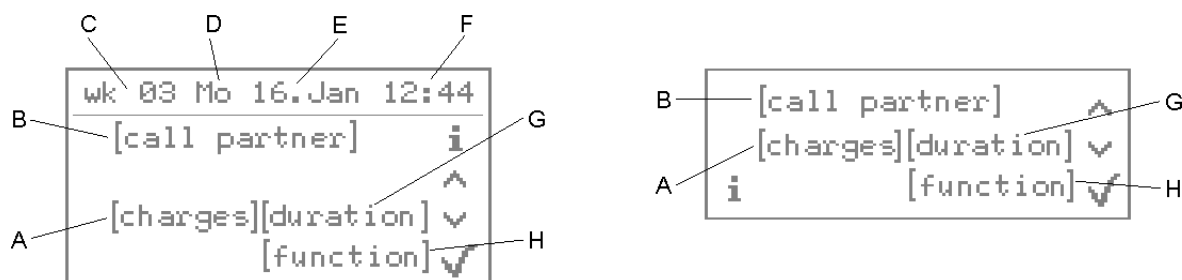

- A Costs (for outgoing external calls)
- B Communication partner
- C Calendar week
- D Weekday
- E Date
- F Time
- G Duration in minutes:seconds (as of 59:59, in hours:minutes)
- H Possible Functions during a Call

Your system telephone shows possible functions during a call in the lower line on the display. Press the  $\nabla$  and  $\blacktriangle$  **softkeys** to scroll through the various options. Press the  $\checkmark$  **softkey** to initiate the function currently displayed.

Press the **i** **softkey** to access additional information about the call.

- Telephone number of the communication partner
- MSN dialled

- Exchange line used (for targeted exchange line access)
- Provider number and name
- Project number and name

Press the **▼** and **▲** **softkeys** to scroll through this information. Press the **✓** **softkey** to go back to the previous view.

### Menu Options during Query Calls

The following information is displayed during a query call:

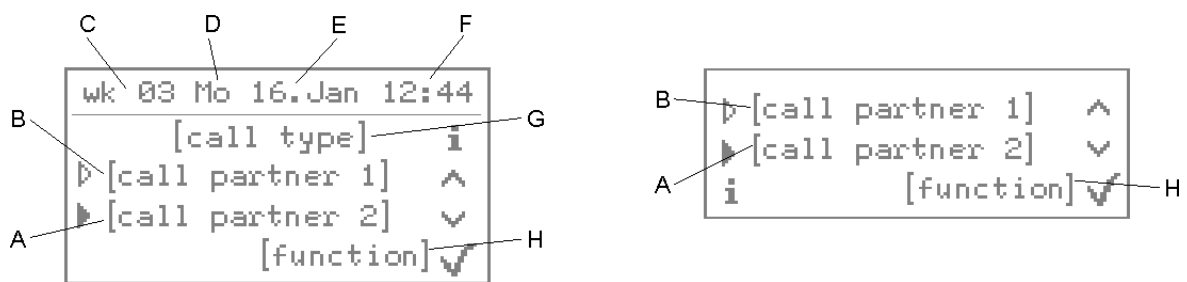

- A Communication partner 2
- B Communication partner 1
- C Calendar week
- D Weekday
- E Date
- F Time
- G Type of call (splitting or conference call)
- H Possible Functions during Query Call

Press the **▶** **softkey** to select the active communication partner. During splitting, the other communication partner who had been active up until now is put on hold in the backgrounds listening to hold music. During a conference call, the status of the call does not change at first. Pressing the **▶** **softkey** during a conference call only activates the communication partner in relation to carrying out the next function.

Your system telephone shows possible functions during a query call in the lower line on the display. Press the **▼** and **▲** **softkeys** to scroll through the various options. Press the **✓** **softkey** to initiate the function currently displayed.

Press the **i** **softkey** to access additional information about the call.

- Telephone number of the communication partner
- MSN dialled
- Exchange line used (for targeted exchange line access)

- Provider number and name
- Duration in minutes:seconds (as of 59:59, in hours:minutes)
- Costs (for outgoing external calls)
- Project number and name

Press the **▼** and **▲** **softkeys** to scroll through this information. Press the **✓** **softkey** to go back to the previous view.

---

## Menu Overview

The main menu (after pressing the menu key) provides access to the menus listed at the end.

### Selection List in information Menu

- version of telephone
- version of PBX
- MSN/name
- configuration
- subscriber CF unconditional
- subscriber CF on busy
- subscriber CF on no reply
- call deblocker
- call restrictor
- ringer tone
- ringer volume
- call waiting
- do-not-disturb
- InterCom permission
- interface
- headset
- hardware
- call charge
- call allowance account
- serial number
- TAM message fwd.

- TAM quick access numbers
- SD card

### **Selection List in functions Menu**

- automatic call acceptance
- boss/secretary function off
- call deblocker (incoming)
- call forwarding: subscriber
- call restrictor (incoming)
- call signal/light
- call waiting
- caller list
- calls list
- delete charges
- delete data
- do-not-disturb
- door functions
- follow-me
- group
- group functions off
- headset
- InterCom permission
- phone lock
- pickup
- project
- relays
- ringer tone
- room monitoring
- scheduled call
- switch configuration
- waiting field reception

### **Selection List in define keys Menu**

- automatic call acceptance

- boss key
- boss/Secretary function off
- call deblocker (incoming)
- call forwarding: subscriber
- call restrictor (incoming)
- call signal/light
- call waiting
- caller list
- calls list
- do-not-disturb
- door function
- exchange line
- exchange line transfer
- external MSN
- follow-me
- group
- group status
- headset
- hotel room
- InterCom
- InterCom permission
- log out all groups
- macro
- MSN/DDI CF
- phone lock
- pickup
- power save mode
- project
- ringer tone
- room monitoring
- relays
- scheduled call
- secretary key
- shift
- speed dialling
- switch configuration
- TAM automatic call recording

- TAM automatic ID
- TAM call recording
- TAM edit announcement
- TAM list
- TAM message fwd.
- TAM readiness
- TAM time control
- TAM voice memo
- text before answering
- Voicemail Center
- VoIP account
- waiting field
- waiting field reception

### **Selection List in the settings Menu**

- backup
  - automatic
  - configuration
  - CF2500 -> SD
  - SD -> CF2500
  - w/o MSN -> CF
- blocking
  - function lock
  - settings lock
- default settings
  - language
  - MSN
  - receiver volume
  - VMC461.2FW>=2.02
- display
  - brightness max.
  - brightness min.
  - contrast
  - date format
  - display backlight
  - inverse view

- time format
- do-not-disturb
  - kind of do-not-disturb
- headset
  - automatic call acceptance
  - headset type
  - headset volume
  - headset ringer
- lists
  - caller list
  - calls list
  - phone book
  - redial list
- power save mode
  - automatic activation
  - configuration
  - idle time
  - phone lock
- signalling
  - attention tone
  - call waiting tone
  - message LED
  - registration status subscriber
  - ringer melody
  - ringer volume
- synchronisation
  - distribute firmware
  - firmware update
  - select PBX
  - synchronisation with PBX
- user settings
  - keys 2nd level
  - macro display
  - menu definition
  - speed dialling key



### **Selection List in answer. machine Menu**

- functions
  - TAM announcement
  - TAM automatic call recording
  - TAM list
  - TAM message forwarding
  - TAM readiness
  - TAM time control
  - TAM voice memo
- settings
  - automatic playback
  - call acceptance time
  - call recording tone
  - edit announcement
  - forwarding announcement
  - forwarding repetitions
  - forwarding repetition time
  - forwarding target
  - forwarding time
  - listen in
  - phone book announcements
  - quick access
  - recording time
  - recording time door
  - remote access
  - remote access toll saver

### **Selection List in diagnosis Menu**

- ISDN
  - line check (BERT)
  - supported service test
- SD card (only COMfortel 2500)
  - test card









---

## Icons

The icons and the functions they execute are listed at the end according to the states and menus in which they can occur.







### Icons in the Idle State

#### **Function of the softkey next to the icon**

-  Switches from the idle state to menu/function level 2.
-  Switches unsuccessful power dialling off early.
-  Enables number presentation suppression (CLIR) for the next call(s).  
Active setting: Number is presented.
-  Disables number presentation suppression (CLIR) for the next call(s).  
Active setting: Number is suppressed.
-  Retrieves a memo (telephone number note).
-  Switches an enabled telephone lock (PIN entry is required).
-  Switches the answering machine on.
-  Switches the answering machine off.

### Icons in Dial Preparation Menu

#### **Function of the softkey next to the icon**

-  Moves the cursor to the left.
-  Moves the cursor to the right.
-  Deletes the last character before the cursor.  
Holding the key (2 seconds) deletes the entire entry.
-  Accepts the entry and dials.
-  Switches back into the idle state.
-  Creates a telephone book entry with the telephone number shown.
-  Creates a scheduled call with the telephone number shown.

## **Menu Icons for Callers and Calls**

### **Function of the softkey next to the icon**

- ▶ Selects the communication partner for splitting or other functions.  
The communication partner is currently inactive/waiting.
- ▶ Display only: The communication partner is currently active.
- ▶ Selects the communication partner for additional functions during a conference call.  
The communication partner is currently inactive.
- ▶ Display only: The communication partner is currently active.
- ✓ Selects the function shown in the lower line of the display.
- ∨ Scrolls to the next function in the lower line of the display.
- ∧ Scrolls to the previous function in the lower line of the display.
- i Opens information about the current call.
- 🔊 Display only: Loudspeaker listening is enabled.
- 🔊 Display only: Hands-free calling is enabled.
- 🔇 Display only: The microphone is switched off (mute).

## **Menu Navigation Icons**

### **Function of the softkey next to the icon**

- ⏪ Switches back in the previous menu or the previous level.
- ∨ Scrolls down to the next entry or to the next function.  
Holding the key allows quicker scrolling.  
Simultaneously pressing the ∧ key lets you jump to the beginning of the list.
- ∧ Scrolls up to the previous entry or the previous function.  
Holding the key allows quicker scrolling.
- ▶ Selects an entry or a function for further editing.
- 📖 Opens a short overview in the telephone book and in the telephone number lists.

## **Selectable Icons**

### **Function of the softkey next to the icon**

- Selects and accepts the function indicated in clear text behind the icon. The function is currently not enabled.
- Selects and accepts the function indicated in plain text behind the icon. The function is currently enabled.
- Selects the currently empty check box.
- Clears the currently selected check box.
- Accepts the changes.

## **Icons in Telephone Number and Text Entry Menus**

### **Function of the softkey next to the icon**

- < Moves the cursor to the left.
- > Moves the cursor to the right.
- ⌫ Deletes the last character before the cursor.  
Holding the key (2 seconds) deletes the entire entry.
- Accepts the entry.
- A-Z Switches the setting for upper and lower case spelling during letter entry.  
Active setting: If the next letter is upper case, then the letters are automatically displayed in lower case.
- A-Z Switches the setting for upper and lower case spelling during letter entry.  
Active setting: All letters are upper case.
- a-z Switches the setting for upper and lower case spelling during letter entry.  
Active setting: All letters are lower case.

## **Icons in define keys Menu**

### **Function of the softkey next to the icon**

- ☎ Initiates entry/change of the telephone number.
- 📄 Initiates entry/change of the name.
- ↻ Switches between various options.
- ➡ Initiates entry/change of the telephone number to be forwarded.
- Accepts the changes.













## **Confirmation Icons**

### **Function of the softkey next to the icon**

- ✓ Confirms the displayed question with "Yes".  
Or: Confirms the display of a change and switches into the idle state.
- ✗ Confirms the displayed question with "No".





## **Icons in Telephone Book Menu**

### **Function of the softkey next to the icon**

-  Opens an expanded display of the contact shown.
-  Initiates the creation of a new contact.
-  Opens a current contact for editing/deleting.
-  Initiates entry/change of the name.
-  Initiates entry/change of the business telephone number.
-  Initiates entry/change of the private telephone number.
-  Initiates entry/change of the mobile telephone number.
-  Initiates entry/change of the comment.
-  Initiates entry/change of the call macro.
-  Accepts the telephone number for subsequent dialling in dial preparation.
-  Adds a special character (only when entering a call macro).
-  Deletes the contact.
-  Initiates selection of a ringer rhythm for the contact.



## **Menu Icons in Telephone Number Lists**

### **Function of the softkey next to the icon**

-  Deletes individual entries from the caller, call and redial lists.
-  Deletes all entries from the caller, call and redial lists.
-  Accepts the telephone number for subsequent dialling in dial preparation.
-  Indicates additional information.

## Icons in Scheduled Call Menu

### **Function of the softkey next to the icon**

-  Opens a current entry for editing/deleting.
-  Initiates the creation of a new entry.











## Icons in Restriction Menu

### **Function of the softkey next to the icon**



- Initiates a change to the restriction for the next function.  
There is currently no restriction.
- Initiates a change to the restriction for the next function.  
The function is currently restricted for guests.
- Initiates a change to the restriction for the next function.  
The function is currently restricted for guests and users.
- Initiates a change to the restriction for the next function.  
The function is currently restricted for guests, users and subadministrators.

## Icons for Answering Machine

### **Function of the softkey next to the icon**











-  Scrolls to next (older) recording.  
During playback: Skips the recording currently being played back.
-  Scrolls to the previous (more recent) recording.  
During playback: Repeats the previous recording or the one currently being played back.
-  Starts the playback of the recording.
-  Interrupts the playback of the recording.
-  Deletes the recording.
-  Switches the answering machine on.
-  Switches the answering machine off.
-  Switches the answering machine off.  
Display: There are new messages in the answering machine list.
-  Display only: The recording is a new message or voice memo.
-  Display only: The recording is an old message or voice memo or one that has already been played back.

### **Function of the softkey next to the icon**

-  Display only: The recording is recording of an actual call.
-  Display only: The SD card is initialised.
-  Display only: Data transfer between SD card and PC.





## **Icons for Voice Mailbox**

### **Function of the softkey next to the icon**





-  Scrolls to next (older) recording.  
During playback: Skips the recording currently being played back.
-  Scrolls to the previous (more recent) recording.  
During playback: Repeats the previous recording or the one currently being played back.
-  Starts the playback of the recording.
-  Interrupts the playback of the recording. If you press this key for a longer period of time, the system will go back to the start of the recording.
-  Deletes the recording. If you press this key for a longer period of time, all messages from the message list will be deleted.
-  The recording is a new message or voice memo.
-  The recording is an old message or voice memo or one that has already been played back.
-  Accepts the telephone number for subsequent dialling in dial preparation.
-  Initiates entry/change of the telephone number of the substitute.
-  Message is saved in the archiv.
-  Opens a current announcement for editing.

## **Voicemail Center Icons**

### **Function of the softkey next to the icon**

-  Skips the recording currently being played back.
-  Repeats the previous recording or the one currently being played back.
-  Starts playback of the new recording that has not yet been listened to.  
Hold the key until "all messages" is displayed: Starts playback of all recordings.
-  Ends playback of the recordings or the recording of the announcement.
-  Deletes the recording currently being played back.

### Function of the softkey next to the icon

-  Deletes all of the recordings.
-  Starts the recording of the announcement.  
Hold the key until "announcem.only" is displayed: Starts the recording of an announcement without the option of recording a message in response.
-  Initiates a change to the announcement.
-  Initiates manual control.
-  Switches to menu/function level 1.



# Using the Configuration Software COMfortel Set

This section provides a general overview of the configuration software COMfortel Set. It describes how to install and generally operate the configuration software.

Moreover, you can find tips on how to use the help in a targeted and efficient manner.

## **Topics**

- [Configuration Software COMfortel Set \(page 50\)](#)
- [Help \(page 61\)](#)

# Configuration Software COMfortel Set

The configuration software COMfortel Set lets you easily set up the system telephone on your computer. The configuration software is contained on the Auerswald Mega Disk contained in the package.

---

## Minimum Requirements for PC for Using Configuration Software COMfortel Set

The computer must meet the following requirements:

- PC with Intel Pentium 800 MHz or compatible processor
- Windows 2000 (as of Service Pack 4), Windows XP (as of Service Pack 3), Windows Vista 32/64-bit (as of Service Pack 2), Windows 7 32/64-bit, Mac OS X (as of 10.5), Linux (as of Kernel 2.6)
- Memory (RAM: 256 MB, recommended 512 MB; for Windows Vista/Windows 7: 512 MB, recommended 1 GB)
- 37 MB free hard disk space for COMfortel Set
- 85 MB free hard disk space for Java Runtime
- USB interface (if will be used): USB specification 1.1 or 2.0
- CD-ROM drive
- Mouse or compatible pointing device
- SVGA graphics card with a resolution of 800 x 600, recommended 1024 x 768, and 65536 colours (16 bit)

---

## Installing COMfortel Set

*Requirements:*

– *The Auerswald Mega Disk contained in the package*

1. Insert the CD (Auerswald Mega Disk) into the CD-ROM drive.

---

**Note:** The following steps describe how to configure the settings on the operating systems, Windows XP, Vista and Windows 7. If using another operating system, refer to the documentation of your operating system.

---

2. If the CD does not start automatically, click **Start** and then **Execute**.
3. Click **Browse** and open the corresponding CD-ROM drive. Double-click the application **autostart.exe** in the main directory. Click **OK**.
4. Follow the instructions on the screen by repeatedly clicking **Next** and selecting the telephone in question.
5. Continue following the instructions on the screen and select the configuration software COMfortel Set.
6. Follow the instructions displayed on the screen.

---

## Starting COMfortel Set

In order to start COMfortel Set, double-click the program shortcut on your computer desktop. Or, proceed as described in the following.

1. Click **Start > All programs > Auerswald > COMfortel > COMfortel Set**.  
You are asked whether you would like to open a configuration file or a telephone configuration.
2. If you would like to instead create a new configuration, click **Cancel**.

---

## Exiting COMfortel Set

1. Open the menu **File > Quit**.  
If you have opened a configuration, you are asked whether you would like to save the configuration beforehand.
2. If you have already saved the configuration, click **No**.

## Configuring the Language of the Configuration Software

1. Open the menu **Options > Language...**
2. Select the desired language from the list field.
3. Click **OK**.
4. Quit COMfortel Set and restart it.

---

## Configuring Interface Used

### *Requirements:*

– Existing PC connection to a PC interface on the PBX or a connected system telephone

1. Open the menu **Options > Interface....**
2. In the **Interface** list field, select one of the following options:
  - COM1, COM2, COM3, COM4:** Enable the existing connection via the serial V.24 interface on the PBX for carrying out the transmission. (No other action is required.)
  - ISDN card (CAPI 2.0):** Enable the existing connection via the CAPI interface on the PBX or a connected system telephone for carrying out the transmission. (No other action is required.)
  - IP network:** Enable the existing connection via the Ethernet interface on the PBX for carrying out the transmission.
  - USB:** Enable the existing connection via the USB interface on the PBX or a connected system telephone for carrying out the transmission. (No other action is required.)

---

### **Note:**

For an indirect PC connection to the system telephone to be configured (for example, a PC connection to the USB port of a COMpact 2206 USB), the selection **ISDN card (CAPI 2.0)** (transmission via the B channel) is significantly faster than via the selection **USB** (transmission via the D channel).

Select **IP network** for a PC connection via the USB interface on the PBX COMmander Business or COMmander Basic.2.

---

3. In the **IP address** entry field, enter the IP address of the PBX. The following entries are possible:
  - IP address with areas from 0 to 255 (example: 192.168.0.240)
4. in the **IP port (default: 7002)** entry field, enter the configuration port for system telephones on the PBX. The following entries are possible:
  - 1 to 65535**
5. Click **OK**.

---

### Configuring V.24 options

If there are transmission problems with the V.24 connection, the transmission rate can be restricted to 9600 Baud. This increases transmission reliability and improves the quality of the connection, for example, on long lines or in a disrupted environment.

1. Open the menu **Options > V.24 options....**
2. Select one of the following options:
  - Safe transmission:** Limits the transmission rate to 9600 Baud.
  - Fast transmission:** Allows the maximum possible transmission rate.
3. Click **OK**.

## Opening Configuration

You can open the configuration of the telephone or a configuration file saved on the hard disk.

### Opening the Telephone Configuration

*Requirements:*

- *An existing PC connection configured correctly in COMfortel Set to a PC interface on the PBX or another connected system telephone*
- *MSN configured for the system telephone*
- *Knowledge of the required PIN*

1. Open the menu **File > Open**.

2. Click **Telephone**.

The **Connection routes** dialogue with the devices connected via the interface configured above opens.

3. Select the telephone whose configuration you would like to open and click **OK**.

The **PIN entry** dialogue opens.

---

**Note:** For operation on the PBXs COMcompact 3000, COMcompact 5010 VoIP, COMcompact 5020 VoIP, COMcommander Basic.2 and COMcommander Business, access to the telephone is only possible via the 6-digit PIN assigned in the PBX. In this case, you need to first select which PIN you would like to enter based on the authority level: the Admin PIN, one of the subadmin PINs or the user PIN that belongs to the telephone.

---

4. Enter the associated PIN and click **OK**.

The configuration is loaded from the telephone. This may take a while.

### Opening a Configuration File

*Requirements:*

- *Configuration file (\*.cf2) saved on the hard disk*

In order to open one of the files previously saved with this program, open the menu **File > Related files** and select the file.

Or, proceed as described in the following.

1. Open the menu **File > Open**.
2. Click **File**.  
A dialogue for selecting the file with the configuration data opens.
3. Switch to the directory where the file is located and select the file.
4. Click **Open** (this text is dependent on the operating system used).

---

## Creating a New Configuration

If you would like to, for example, to create a configuration for a telephone before the required connection to the PBX or to the PC has been established, you can open an empty configuration as described in the following. In this case, you also need to specify the number and position of the existing expansion modules in the configuration of a COMfortel 2500.

1. Open the menu **File > New**.
2. Select the type of telephone for which you would like to create a configuration.
3. Select the type of PBX on which you would like to operate the telephone.
4. Click **OK**.
5. Only COMfortel 2500: Open the page **COMfortel 2500+Xtension30**.
  - a) In the **Number of COMfortel Xtension30 Modules** list field, select the number of existing expansion modules.
  - b) In the **Position of the COMfortel Xtension30 Modules** list field, select one of the following options:
    - right of the telephone:** The expansion modules are on the right side of the telephone, on the side facing away from the receiver.
    - left to the telephone:** The expansion modules are on the left side of the telephone, next to the receiver.

## Saving Configuration

The configuration can be saved on the telephone or as a file on the PC.

### Saving Configuration on Telephone

*Requirements:*

- An existing PC connection configured correctly in COMfortel Set to a PC interface on the PBX or another connected system telephone
- MSN configured for the system telephone
- An open configuration and the required PIN, if necessary

1. Open the menu **File > Save**.

2. Click **Telephone**.

The **Connection routes** dialogue with the devices connected via the interface configured above opens.

3. Select the telephone on which you would like to save the configuration and click **OK**.

The **PIN entry** dialogue opens.

---

**Note:** For operation on the PBXs COMcompact 3000, COMcompact 5010 VoIP, COMcompact 5020 VoIP, COMcommander Basic.2 and COMcommander Business, access to the telephone is only possible via the 6-digit PIN assigned in the PBX. In this case, you need to first select which PIN you would like to enter based on the authority level: the Admin PIN, one of the subadmin PINs or the user PIN that belongs to the telephone.

---

4. Enter the associated PIN and click **OK**.

The configuration is saved on the telephone. This may take a while.

### Saving Configuration File on PC

*Requirements:*

- Open configuration

1. Open the menu **File > Save**.



2. Click **File**.  
A file location dialogue opens.
3. Select the directory in which you would like to save the file.
4. Enter a filename with the ending .cf2 and click **Save** (this text is dependent on the operating system used).

---

## Close the Configuration

1. Open the menu **File > Close**.  
You will be asked whether you would like to save the configuration beforehand.
2. If you have already saved the configuration, click **No**.

---

## Using Print Functions

### *Requirements:*

#### *– Open configuration*

1. Open the menu **File > Printing**.
2. Select or clear the **Assign function keys** check box.
  - Lettering labels with the current function key assignment are printed.
  - The lettering labels are not printed.
3. Select or clear the **Telephone book** check box.
  - The telephone book in the configuration is printed.
  - The telephone book is not printed.
4. Select or clear the **Project list** check box.
  - The project list in the configuration is printed.
  - The project list is not printed.

5. Click **OK**.

If you have selected the **Assign function keys** check box, a print preview dialogue for viewing the lettering labels opens.

---

**Note:** If you have cleared the **Assign function keys** check box, proceed to the penultimate step.

---

6. If you would like to configure the colour settings for the lettering labels, click **Colour selection**.

a) Click **Change** next to one of the following options:

**Colour of the text for level 1:** Enables changes to the colour of the text at level 1.

**Colour of the text for level 2:** Enables changes to the colour of the text at level 2.

**Background colour:** Enables changes to the background colour.

b) Change the colour as you like, and click **OK**.

c) Select or clear the **Use these colours for all labels** check box.

The colour settings are used for the print out all of the lettering labels.

The colour settings are only used for the print out of the lettering label shown.

d) Click **OK**.

7. In the list field under the **Colour selection** button, select one of the following options:

**centre justified text:** Enables centre justified text.

**left-aligned:** Enables left-aligned text.

---

**Note:** In the factory settings, the text is centre justified.

---

8. Click **OK**.

The print dialogue for the operating system opens.

9. Click **OK** (this text is dependent on the operating system used).

---

## Operating Instructions for COMfortel Set

The operating instructions for COMfortel Set contain the following topics:

- Navigation
- Entry and Selection Fields
- Creating and Deleting Table Entries

### Navigation in COMfortel Set

After opening a configuration, the current areas are displayed in a directory tree. To show the organisation of the topics clearly, most topics have been consolidated under a main topic.

Double-click the desired main topic or the plus sign next to the main topic to open the underlying list of topics. Then click the topic you want.

The topic you have chosen opens on the page to the right.

You can select sub-topics directly on some pages by clicking tabs.

### Entry and Selection Fields

---

**Note:** The menu bar is not required for processing the page. All entries and changes are made using the mouse or keyboard directly in the pages.

---



An empty field normally indicates that a name or number is to be entered. Click within the field in question and use the keyboard to enter a number or desired text.

In order to change an existing entry, double-click the entry to be overwritten. The field then becomes blue and can either be overwritten directly or the existing text can be deleted using the delete/backspace key.



For functions that offer more than just being switched on and off but only have a few options to choose from, the field already contains a default setting. To change this, click the opened list field to make a selection.

- If this is a single field with an arrow pointing downward, open the list field by clicking the field.
- If there are multiple fields in a table column (without an arrow pointing downward), open the list field by double-clicking the field.

- For some functions, a small circular button (radio button) is located next to the setting options listed. The selected setting is indicated by a black dot inside the circle. The setting is changed by clicking an empty circle. Selecting this setting option simultaneously deactivates any other previous selection.
- A square check box indicates a switching function. An empty check box means "off" and "no"; a check mark on the other hand, means "on" and "yes". The switchover is done by simply clicking the box.

### **Creating and Deleting List Entries**

To create new list entries, fill the empty entry fields in the lower table row. Additional rows are then added to the list.

To delete an entry, an entire line can be deleted. To do this, double-click in an field in the line to be deleted. The field is then selected as indicated by the colour change. Right-clicking opens a menu. Click **Delete**. You can delete multiple fields by dragging your mouse with the left mouse button pressed to select multiple fields.

# Help



Via the help you can access the entire operation and configuration instruction for the system telephone.

---

## Opening the Help Topic-Relevantly

Below the directory tree, there is a window containing links to several help topics. The offered help topics refer to the currently open configuration page.

- Click the link to go to the desired help topic.

The corresponding help page opens. You can navigate back and forward within the selected topic by clicking the  and  icons.

- Press the key F1.

The help opens and displays the description of the configuration software.

---

**Note:** You can always access the entire operating and configuration instructions for the system telephone via the navigation.

---

---

## Navigating in the Help Window



There are several ways to navigate through the help.

### Navigating via the Table of Contents

Click the **Table of Contents** (this text is dependent on the operating system used) tab to go to the table of contents (the tab is highlighted in yellow)

The table of contents will be displayed on the left-hand side of the help window as a directory tree.

By clicking one of the topics in the table of contents, you can open the belonging help page on the right-hand side of the help window.

The  icon indicates that further topics are available under a specific topic. Click this icon to expand the subordinate topics. You can close the subordinate topics again by clicking the  icon.

---

**Note:**



The table of contents area and the selected page are separated by a vertical line or a scroll bar. To enlarge the area (this automatically makes the other areas smaller), click and hold the cursor above the separator line and slide the line to the location you want. This setting only applies to the help window currently open.

The currently opened topic is highlighted in the table of contents (for example, with a grey background). Scrolling through the table of contents may cause this highlighting to disappear. By clicking the  icon in the help window, you can display the currently open help page in the table of contents again.

---

### **Navigating via Expanding Texts**

Some help texts contain expanding texts that flip down. Expanding text is indicated by a blue font and is underlined. In addition, the  icon is shown behind the expanding text.

You can expand the text by clicking the  icon or the line. You can close the text again by clicking the  icon or the line.

### **Navigating via the Index**

Click the **Index** (this text is dependent on the operating system used) tab to go to the index (the tab is highlighted in yellow)

The index will be displayed on the left-hand side of the help window.

By clicking a letter of the alphabet, you can go directly to the keywords under this letter.

By clicking the desired keyword, you can open the belonging help page on the right-hand side of the help window.

---

**Note:**

The index area and the selected page are separated by a vertical line or a scroll bar. To enlarge the area (this automatically makes the other areas smaller), click and hold the cursor above the separator line and slide the line to the location you want. This setting only applies to the help window currently open.

By clicking the  icon in the help window, you can display the currently open help page in the table of contents.

---

### **Navigating by Browsing**

By clicking the  icon, you can go to the next page of the instruction.

By clicking the  icon, you can go to the previous page of the instruction.

### **Navigating via the Back Button**

Clicking the  icon takes you back to the previously opened help page.

---

**Note:** You may have to scroll back to the beginning of the currently displayed help page in order to access the icon.

---

### **Navigating via Links**

Some help texts contain links to subordinate topics or to more detailed information. A link is indicated by a blue font and is underlined.

By clicking a link, you can go to the belonging help page.

### **Navigating via Breadcrumbs**

The path you took to get to the currently open page is displayed above the help text. The path consists of the titles of the topics superordinate to the current topic. The superordinate topics are shown in a blue font and the current topic is shown in a grey font.

By clicking a superordinate topic, you can go to the belonging help page.

## Searching in the Help

You can search the entire help for one or several terms.

1. Click the **Search** tab (this text is dependent on the operating system used).  
The tab is activated (it is highlighted in yellow). The left area of the help window contains a input field for the keywords and a button for starting the search.
2. Enter the desired term in the entry fields.

---

### Note:

The character \* can be used as a placeholder (wildcard) in a search. A search using teleph\* results, e.g., in hits for telephone, telephoning and telephone book.

If you enter several terms, the Help texts which contain all these keywords will be displayed irrespective of the sequence and context.

---

3. Click **Search** (this text is dependent on the operating system used).  
Help is searched; this may take some time. Afterwards, the topics that contain the search term are listed. The sequence within this list is determined by the number of hits and the importance of the search term found. The higher the value displayed under **in %**, the more important the help text is to the search.
4. Click the desired **Title** within the list.  
The corresponding help page will be opened on the right-hand side of the help window.

---

### Note:

Some browsers, e. g. Internet Explorer 7, also highlight the identified search terms within the help text.

The search area and the selected page are separated by a vertical line or a scroll bar. To enlarge the area (this automatically makes the other areas smaller), click and hold the cursor above the separator line and slide the line to the location you want. This setting only applies to the help window currently open.

By clicking the  icon in the help window, you can display the currently open help page in the table of contents.

---



---

## Printing from within the Help

You can print the currently displayed help page using the print function of the help.

---

### Note:

If the displayed help page includes expanding texts, expand all texts you want to print.











If you want to print only part of the displayed help page, mark the corresponding text by clicking and drawing with the left mouse key. Afterwards, select **Selection** as print area in the print dialog box.

---

1. In the help window, click the  icon.  
The print dialog box opens.
2. Select the desired printer.
3. Click **Print**.

---

## Icons in the Help Window

- |   |  |
|---|--|
|  | Clicking the icon takes you back to the previously opened help page.   |
|  | Clicking the icon takes you to the next page of the instruction.   |
|  | Clicking the icon takes you back to the previous page of the instruction.  |
|  | Clicking the icon displays the opened help page in the table of contents.  |
|  | Display: The expanding text is currently closed.<br>You can open the text by clicking the icon or the line.      |
|  | Display: The expanding text is currently shown.<br>You can hide the text by clicking the icon or the line.       |
|  | Clicking the icon opens the print dialog box.  |
|  | Display: Subordinate topics are closed.<br>Clicking the icon opens the subordinate topics.                       |
|  | Display: Subordinate topics are shown.<br>Clicking the icon closes the subordinate topics.                       |
|  | Display: The topic does not have any subordinate topics.<br>Clicking the icon opens the corresponding help page. |

# Telephoning

This section describes the various types of telephoning that your telephone provides.

## Topics

- [Incoming Calls \(page 67\)](#)
- [Call Waiting Calls \(page 71\)](#)
- [Outgoing Calls \(page 75\)](#)
- [Calls \(page 83\)](#)
- [Query Calls \(page 86\)](#)
- [Transfer \(page 89\)](#)
- [Conference Calls \(page 93\)](#)
- [Hands-free Calling \(page 96\)](#)
- [Loudspeaker Listening \(page 98\)](#)
- [Headset Calls \(page 100\)](#)

# Incoming Calls

The following types of calls apply to incoming calls:

- Alarm calls
- External calls
- Internal calls
- Group calling (a call directed to a group)
- InterCom calls
- External callback calls
- Internal callback calls
- Scheduled calls
- Door calls
- Call deblocker calls (calls enabled despite do-not-disturb)
- Wake-up calls
- Other calls

---

## Options During an Incoming Call

During an incoming call, the following actions are possible:

### **Accept an Incoming Call**

If you receive a call and would like to talk with the caller, you can accept the incoming call as you would normally by picking up the receiver.

### **Reject an Incoming Call**

If you receive a call but you do not want to talk to the caller, you can reject the incoming call. The caller receives a busy signal – in as far as no other telephones are called (for example, in a group call).

### **Forward an Incoming Call**

If you receive a call but you do not want to talk to the caller yourself, you can forward the incoming call to any internal or external destination number.

## Put an Incoming Call on Hold

If you receive a call but would like to postpone accepting the call for a while, you can put the incoming call on hold. The caller hears the hold music.

### Additional Options

- [Forwarding Incoming Calls to Answering Machine \(page 368\)](#)

---

## Accepting Incoming Calls

### Requirements:

- *Knowledge of the telephone and its menu options*

When you receive a call, proceed as described in the following.

- Pick up the receiver or press the **hook key**.

You are connected with the caller.

---

### Note:

If you are not present once in a while or cannot accept the call for any other reason, the telephone number of the caller is saved in the caller list (in as far as the telephone number is available and the call type is to be entered in the caller list).

Calls made from the telephone or from the PBX (wake-up calls, alarm calls, door calls, scheduled calls) are displayed in plain text and, if necessary, can be confirmed by pressing the **✓ softkey** (alarm calls are confirmed after first picking up the receiver).

---

## Rejecting Incoming Calls

*Requirements:*

- *Knowledge of the telephone and its menu options*

When you receive a call, proceed as described in the following.

1. Select **reject**.

2. Press the **✓ softkey**.

The caller receives a busy signal – in as far as no other telephones are called (for example, in a group call).

---

## Hold incoming calls

*Requirements:*

- *Knowledge of the telephone and its menu options*

When you receive a call, proceed as described in the following.

1. Select **hold incoming**.

2. Press the **✓ softkey**.

You will hear the internal dial tone. The caller on hold hears the hold music.

3. Select **back**.

4. Press the **✓ softkey**.

You are connected with the caller.

---

## Forwarding Incoming Calls

---

**Important:** Only available for operation on the PBXs COMpact 3000, COMpact 5010 VoIP, COMpact 5020 VoIP, COMmander Basic.2 and COMmander Business.

---

*Requirements:*

- *Knowledge of the telephone and its menu options*

When you receive a call, proceed as described in the following.

1. Select **call deflection**.
2. Press the **✓ softkey**.
3. Enter the destination number or press the **telephone book key** to select the telephone number you want in the telephone book.

---

**Important:** Enter telephone numbers exactly as when dialling, for example, external telephone numbers always with a leading exchange line access number. (exception: direct exchange access). The default exchange line access number on the PBX is "0" in the factory settings; however, this can be changed for several PBXs (see the PBX manual).

---

4. Press the **✓ softkey**.

The subscriber is called.

---

**Note:** If the destination number is saved on the programmable function key (speed dialling key), you can forward the call by simply pressing this key and then confirming with the **✓ softkey**. The previous function selection via the display is no longer applicable.

---

# Call Waiting Calls

During a call, you are made aware of another call (external or internal subscriber, alarm or someone at the door) by a call waiting signal (tone and/or blinking hook LED).

---

## Options During a Call Waiting Call

During a call waiting call, the following actions are possible:

### Reject a Call Waiting Call

If you receive another call while you are already on a call and you do not want to speak with the second caller, or you do not want to interrupt the first call, you can reject the call waiting call. The caller receives a busy signal – in as far as no other telephones are being called (for example, in a group call).

### Accept the Call Waiting Call

If you receive another call while you are already on a call and you would like to speak to the second caller, or you would like to end the current call, you can accept the call waiting call. After accepting, you are connected with the other caller. Your previous communication partner hears the hold music.

### Forward Call Waiting

If you receive another call while you are already on a call and personally do not want to talk with the second caller, or you do not want to interrupt the current call, you can forward the call waiting call to any internal or external destination number.

### Switch off the Call Waiting Tone

If you receive another call while you are already on a call but you would like to postpone accepting the second call for a while, you can switch off the call waiting tone. The second call will continue to try to get through and you can accept it at any time.

## Rejecting Call Waiting Calls

*Requirements:*

- *Knowledge of the telephone and its menu options*
- *Call waiting enabled*

When call waiting signals that there is an incoming call, proceed as described in the following.

1. Select **reject**.
2. Press the **✓ softkey**.

The caller receives a busy signal – in as far as no other telephones are being called (for example, in a group call).

---

## Accepting Call Waiting

*Requirements:*

- *Knowledge of the telephone and its menu options*
- *Call waiting enabled*

When call waiting signals that there is an incoming call, proceed as described in the following.

1. Select **accept**.
2. Press the **✓ softkey**.

You are connected with the caller. Your previous communication partner hears the hold music.

---

**Note:** If you first hang up the receiver to end the current call, your telephone then rings and you can accept the incoming call as you would normally.

---



---

## Forwarding Call Waiting

---

**Important:** Only available for operation on the PBXs COMpact 3000, COMpact 5010 VoIP, COMpact 5020 VoIP, COMmander Basic.2 and COMmander Business.

---

*Requirements:*

- Knowledge of the telephone and its menu options
- Call waiting enabled

When call waiting signals that there is an incoming call, proceed as described in the following.

1. Select **call deflection**.
2. Press the **✓ softkey**.
3. Enter the destination number or press the **telephone book key** to select the telephone number you want in the telephone book.

---

**Important:** Enter telephone numbers exactly as when dialling, for example, always enter external telephone numbers with a leading exchange line access number. (exception: direct exchange access). The default exchange line access number on the PBX is "0" in the factory settings; however, this can be changed for several PBXs (see the PBX manual).

---

4. Press the **✓ softkey**.

The subscriber is called.

---

**Note:** If the destination number is saved on the programmable function key (speed dialling key), you can forward the call by simply pressing this key and then confirming with the **✓ softkey**. The previous function selection via the display is no longer applicable.

---

## Switching off Call Waiting Tone

*Requirements:*

- *Knowledge of the telephone and its menu options*
- *Call waiting enabled*

When call waiting signals that there is an incoming call, proceed as described in the following.

1. Select **call wait.off**.
2. Press the **✓ softkey**.

The second call will continue to try to get through and you can accept it at any time.

# Outgoing Calls

Outgoing calls are calls that you have initiated yourself.

---

## Options for Outgoing Calls

An outgoing call can be initiated in two ways:

### Dialling the Telephone Number

If you have already picked up the receiver before dialling, the telephone number that you have entered is dialled immediately.

### Dialling the Telephone Number with Dial Preparation

Dial preparation – first dialling and then picking up the receiver – makes it possible to check the telephone number entered and, if necessary, to correct it before the connection is established.

### Dialling the Telephone Number on Direct Exchange Line Access

If your system telephone has been configured as a direct exchange access point using the configuration manager on the PBX, you will hear an external dial tone directly after picking up the receiver. The manner in which an outgoing call is initiated is different than the manner in which a normal call is initiated, as described previously.

### Initiating External Calls with Number Presentation Suppression

If you prefer that the person you are calling does not see your telephone number, you can use number presentation suppression.

#### Additional Options

- [Initiating Targeted Exchange Line Access \(page 324\)](#)
- [Initiating a Targeted VoIP Access Point \(page 333\)](#)
- [Dialling from Telephone Book \(page 105\)](#)
- [Dialling from Caller List \(page 138\)](#)
- [Dialling from Calls List \(page 132\)](#)
- [Dialling from Redial List \(page 128\)](#)

---

## Picking up Receiver and Dialling Telephone Number

*Requirements:*

– *Knowledge of the telephone and its menu options*

1. Pick up the receiver or press the **hook key**.
2. Dial a telephone number.

---

**Important:** Do not forget to dial the exchange line access number for external telephone numbers or press the ✓ **softkey** after **public exchange**. (Exceptions: direct exchange access)

**Note:** As soon as you have dialled the first digit, you can cancel dialling by pressing the ✓ **softkey** and starting again.

---

Once you have finished dialling the telephone number, the subscriber is called.

---

## Dialling Telephone Number with Dial Preparation

*Requirements:*

– *Knowledge of the telephone and its menu options*

1. Dial a telephone number.

---

**Important:** Enter telephone numbers exactly as when dialling, for example, external telephone numbers always with a leading exchange line access number. (exception: direct exchange access).

**Note:** You can make corrections, if necessary, while entering the telephone number.

---

2. Pick up the receiver or press the **hook key**.

---

**Note:** If you would like to exit the menu without dialling the telephone number entered, press the **exit key**.

---

## Initiating External Calls with Number Presentation Suppression

### Requirements:

- Knowledge of the telephone and its menu options
- The service attribute CLIR (selective number presentation suppression) enabled by the network provider
- Telephone number display enabled on the PBX

1. Press the  **softkey** to activate suppression for the next call.

The display will show darkened eyeglasses  as an indication that number presentation suppression has been enabled.

2. Dial a phone number (an external phone number with an exchange line access number).
3. Pick up the receiver or press the **hook key**.

The subscriber is called.

Number presentation suppression remains enabled until the  **softkey** is pressed again.

---

## Dialling Telephone Number on Direct Exchange Line Access

### Requirements:

- Knowledge of the telephone and its menu options
- Telephone is configured as a direct exchange access point via the PBX

In order to dial an external telephone number on a direct exchange line access point, pick up the receiver and enter the external telephone number without the exchange line access number.

In order to carry out other types of calls (for example, internal or short-code), proceed as described in the following.

1. Pick up the receiver or press the **hook key**.

You will hear the external dial tone.

2. Select **internal**.

You will hear the internal dial tone.

3. Dial an internal telephone number.

Once you have finished dialling the telephone number, the subscriber is called.

---

**Note:** If you would like to use dial preparation or, for example, make an entry in the telephone book or configure a speed dialling key, you must press the star key twice beforehand for internal and short-code calls.

---

---

## Options for Unsuccessful Calls

The following options are available for unsuccessful call:

### Initiating Callback on Busy

If you cannot get through to a busy subscriber despite repeated attempts, you can initiate a callback on busy. The PBX supports the service attribute "Automatic callback on busy (CCBS)". This service attribute is required for an external call.

If you have initiated a callback, as soon as the other subscriber has hung up the receiver to end the call, the PBX (for an internal call) or central office (for an external call) calls you. If you then pick up the receiver, the other subscriber is called. If the other subscriber picks up the receiver, the connection for the call is established. This deletes the callback procedure in the PBX/central office.

### Initiating Callback on No Response

If the person being called does not pick up the receiver, you can configure callback on no response in order to reach this person without having to call him repeatedly. The function can be used for both internal and external calls. The service attribute "Callback on no response (CCNR)" is supported by the PBX. This service attribute is required for external calls.

If you have initiated a callback, as soon as the other subscriber has hung up the receiver to end the call, the PBX or central office calls you. If you then pick up the receiver, the other subscriber is called. If the other subscriber picks up the receiver, the connection for the call is established. This deletes the callback procedure in the PBX/central office.

## Initiating Priority Call for Do-not-disturb

If, for example, a person must absolutely be reached in an emergency despite the do-not-disturb function, the do-not-disturb function can be circumvented by a priority call from an internal telephone.

### Additional Options

- [Executing Power Dialling \(page 283\)](#)
- [Configuring Scheduled Call as Call Reminder \(page 310\)](#)

---

## Initiating Callback on Busy

### Requirements:

- Knowledge of the telephone and its menu options
- For external calls: The given technical requirements for a callback on busy (for instance, not all network providers provide callback on a Point-to-Point connection)

If the connection you are calling is busy, proceed as described in the following.

1. Select **recall**.
2. Press the  **softkey**.

If callback is configured, you receive the message **recall activated**.

3. Hang up the receiver.

---

**Note:** When operated on the PBXs COMpact 3000, COMpact 5010 VoIP, COMpact 5020 VoIP, COMmander Basic.2 and COMmander Business: If you would like to delete the callback, press the  **softkey** in the redial list.

---

As soon as the connection is no longer busy, you are called by the central office/PBX for a period of 20 seconds.

4. Pick up the receiver to carry out the callback.

---

### Note:

If you do not pick up the receiver within the 20 seconds during which the central office/PBX calls you, the callback instruction is deleted.

If you would like to cancel the callback, select **reject**.

---

If you pick up the receiver, the subscriber is called.

---

**Note:**

You also have the option of letting the central office call you as soon as one of the B-channels on the previously called ISDN connection is available. If the person for which you have set up callback is telephoning on the other B-channel, callback will remain unsuccessful.

A callback is tried up to 45 minutes by the central office/PBX. If the called person did not finish his call until then, the callback will be deleted automatically.

---

---

## Initiating Callback on No Response

*Requirements:*

- *Knowledge of the telephone and its menu options*
- *For external calls: The given technical requirements for a callback on no response (for instance, not all network providers provide callback on a Point-to-Point connection)*
- *For external calls: the service attribute CCNR (Callback on no response) enabled with the network provider*

If no one answers on the connection you are calling, proceed as described in the following.

1. Select **recall**.
2. Press the  **softkey**.

If callback is configured, you receive the message **recall activated**.

3. Hang up the receiver.

---

**Note:** When operated on the PBXs COMpact 3000, COMpact 5010 VoIP, COMpact 5020 VoIP, COMmander Basic.2 and COMmander Business: If you would like to delete the callback, press the  **softkey** in the redial list.

---

As soon as the connection is used, the central office/PBX calls you for period of 30 seconds (or only 15 seconds for external callback).



4. Pick up the receiver to carry out the callback.

---

**Note:**

If you do not pick up the receiver within the 30 seconds (or 15 seconds) during which the central office/PBX calls you, the callback instruction is deleted.

If you would like to cancel the callback, select **reject**.

A callback on an external subscriber is tried up to 45 minutes by the central office. If the called person did not finish his call until then, the callback will be deleted automatically.

---

If you pick up the receiver, the subscriber is called.

---

## Initiating Priority Call for Do-Not-Disturb

*Requirements:*

- *Knowledge of the telephone and its menu options*
- *The subscriber who is called has configured **all (PBX)** as kind of do-not-disturb*

If the internal telephone you are trying to call is busy because it is set to do-not-disturb, proceed as described in the following.

- Wait ten seconds.

The subscriber is now called.

---

## Ending a Query Call

*Requirements:*

- *Knowledge of the telephone and its menu options*

If you make a query call and the number is busy but there is no response, proceed as described in the following.

---

**Important:** Do not hang up the receiver as this will disconnect any calls waiting or will initiate an unannounced transfer of the call to another internal telephone.

---

1. Select **back**.

---

**Note:** If you would like to try this with another telephone number, select **dial again**. You can then dial a new telephone number, without having to explain to the person waiting on the other line that you are trying again.

---

2. Press the  **softkey**.

You are now reconnected with the person waiting on the other line.

# Calls

The system telephone allows you to make internal and external calls on the PBX. Internal calls are toll-free.

---

## Options during a Call

During a call, the following actions are possible:

### Retrieving Information about a Call

During a call, you see information about the call and your communication partner on the display as well as general time information (date, time, calendar week, weekday).

### Sending DTMF Signals

During an existing connection, you can use the keypad to send DTMF signals (tones used in DTMF dialling) to operate an answering machine remotely, for example. The digits dialled are shown on the display.

### Mute

If you would like to discuss something with another person in the room without your communication partner on the telephone being able to hear, you can temporarily mute the call.

### Additional Options

- [Initiating a Query Call \(page 86\)](#)
- [Transfer \(page 89\)](#)
- [Creating a Memo \(page 273\)](#)
- [Executing Pickup during Call \(page 279\)](#)
- [Executing Project Assignment during a Call \(page 293\)](#)
- [Configuring Scheduled Call as Call Reminder \(page 310\)](#)
- [Executing Call Recording \(page 422\)](#)

## Retrieving Information about a Call

*Requirements:*

- *Knowledge of the telephone and its menu options*

During a call, proceed as described in the following.

1. Press the **i softkey**.  
All the available information about a call is displayed.
2. Press the **✓ softkey** to end the display.

---

## Sending DTMF Signals

*Requirements:*

- *Knowledge of the telephone and its menu options*

During a call, proceed as described in the following.

- Enter the digits and characters. The following entries are possible:

Digits and the characters \* and #

The digits and characters dialled are shown on the display and you hear the corresponding tones.

---

## Muting a Call

*Requirements:*

- *Knowledge of the telephone and its menu options*

During a call, proceed as described in the following.

1. Press the **microphone key**.

The microphone on the receiver, device or headset is switched off. The  symbol is shown in the display.

2. If you would like to switch the microphone on again, press the **microphone key** again.

---

## Ending a Call

After your communication partner ends the call, your telephone goes into the idle state. If you wait to hang up the receiver for a few seconds, you will hear the busy signal on the receiver and then also on the loudspeaker of the base system, in case the receiver was accidentally hung up incorrectly.

### *Requirements:*

- *Knowledge of the telephone and its menu options*

During a call, proceed as described in the following.

- Hang up the receiver.

---

**Note:** If you would like to end a current call and then immediately make a new call, press the **hook key** instead and start dialling the next number within 30 seconds.

---

## Query Calls

During a query call, you are talking with one subscriber while your previous communication partner is on hold on the PBX in the background listening to hold music.

A query call is initiated either by calling a query call subscriber, using pick-up during a call, or by accepting a call signalled by call waiting.

---

### Initiating a Query Call

*Requirements:*

– *Knowledge of the telephone and its menu options*

During a call, proceed as described in the following.

1. Select **query/transfer**.
2. Press the ✓ **softkey**.

You will hear the internal dial tone. Your current communication partner is kept on hold on the PBX and is listening to hold music.

3. Enter a telephone number.

---

**Important:** Enter telephone numbers exactly as when dialling, for example, always enter external telephone numbers with a leading exchange line access number.

---

The subscriber is called.

---

**Note:**

If the telephone number of the query call subscriber is located in the telephone book of the telephone, you can initiate a query call by dialling directly out of the telephone book (also without previously selecting **query/transfer**).

If the telephone number of the query call subscriber is saved on one of the freely programmable function keys (speed dialling key), you can initiate the query call by simply pressing this key (without previously selecting **query/transfer**).

---

## Options during a Query Call

The following actions are possible during a query call:

### Splitting

You can use at the splitting function to switch between your two communication partners.

### Ending One of the Two Calls

When you end a query call and would like to continue talking with one of the communication partners, you can specifically end the call with the other communication partner separately. Of course, one of your communication partners can simply hang up so that you can continue talking with the other communication partner alone.

### Connecting Both Communication Partners

If you would like to let your communication partners speak with each other, you can connect them together.

---

## Splitting

*Requirements:*

- Knowledge of the telephone and its menu options
- Initiated query call

During a query call, proceed as described in the following.

- If necessary, press the **▶ softkey** in front of the name or telephone number of the communication partner to whom you would like to change.

The active communication partner is indicated by **▶** , and the waiting communication partner by **▶** .

You continue to conduct a query call. The other communication partner is now active.

## Ending One of the Two Calls

*Requirements:*

- *Knowledge of the telephone and its menu options*
- *Initiated query call*

If one of your two communication partners hangs up the receiver, you remain connected with the other one.

Or, during a query call, proceed as described in the following.

1. If necessary, press the **▶ softkey** in front of the name or telephone number of the communication partner with whom you would like to end the call.

The active communication partner is indicated by **▶** , and the waiting communication partner by **▶** .

2. Select **curr.call canc..**

3. Press the **✓ softkey**.

You then conduct an individual call with the communication partner who had previously been on hold.

---

## Connecting Both Communication Partners

*Requirements:*

- *Knowledge of the telephone and its menu options*
- *Initiated query call*
- *To connect two external communication partners, the following is required: Authorization in the PBX for **Transfer of external calls to external***

To connect both communication partners, hang up the receiver during a query call.

Or, proceed as described in the following.

1. Select **conn. both calls**.

2. Press the **✓ softkey**.

Both communication partners are connected with each other.



# Transfer

A communication partner can be transferred or connected to an internal or external subscriber.

---

## Options for Transferring a Call

During an existing call, the following options are available for transferring a call:

### Transfer with Announcement

In order to transfer a call, first initiate a query call, announce the call and then connect both communication partners.

### Transfer without Announcement

If you would like to transfer an external communication partner to another internal subscriber, you do not have to wait until the subscriber being called via the query call accepts the call; you can hang up the receiver while this call is being made. The internal subscriber will continue to be called.

### Placing the External Communication Partner in the Waiting Loop

If the internal subscriber to which you would like to transfer an external communication partner is busy, you can place the external communication partner in the waiting loop of this subscriber.

---

**Note:** If, for example, you have accepted a call signalled by call waiting and have therefore established a query call, you can place this call in the waiting loop in the same manner. The communication partner to be transferred must be the active communication partner (indicated by ► ).

---

### Calling a Third Internal Subscriber and Transferring to an Active Communication Partner

Assuming that you have gained an additional communication partner from a call, for example, from accepting a call signalled by call waiting, and this second communication partner would like to now be transferred to somebody else. You can now initiate a third call that connects the second and third communication partners with each other and then continue telephoning with your first communication partner.

## Transfer with Announcement

### *Requirements:*

- *Knowledge of the telephone and its menu options*
- *Initiated query call*
- *To connect two external communication partners, the following is required: Authorization in the PBX for **Transfer of external calls to external***

During a query call, proceed as described in the following.

1. Select **conn. both calls**.
2. Press the **✓ softkey**.

Both communication partners are connected with each other.

---

## Transfer without Announcement

### *Requirements:*

- *Knowledge of the telephone and its menu options*
- *Internal transfer destination*

During a call, proceed as described in the following.

1. Select **query/transfer**.
2. Press the **✓ softkey**.

You will hear the internal dial tone. Your current communication partner is kept on hold on the PBX and is listening to hold music.

3. Dial an internal telephone number.

The subscriber is called.

4. Hang up the receiver.

The internal subscriber will continue to be called. If the subscriber accepts the call, the connection is established.

If the subscriber being called does not accept the call, the call is transferred back to your telephone 60 seconds later (your telephone rings).

---

**Note:** In order to carry out an **open query call**, dial the internal basis telephone number + park position and hang up, instead of dialling the internal telephone number (see also the PBX manual). To make this operation more convenient, you can save the internal basis telephone number + park position on one or more freely programmable function keys (speed dialling key). The LEDs for the speed dialling keys then indicate whether a park position is available or busy.

---

---

## Placing External Communication Partner in Waiting Loop

### *Requirements:*

- *Knowledge of the telephone and its menu options*
- *Internal transfer destination*

If the internal telephone to which you are trying to transfer a call is busy, proceed as described in the following.

1. Select **waiting loop**.
2. Press the **✓ softkey**.
3. Hang up the receiver.

The external communication partner continues to listen to hold music.

As soon as the internal subscriber hangs up the receiver, this external communication partner is called. Once he accepts the call, he is connected with the subscriber in the waiting loop.

---

### **Note:**

If the internal subscriber does not answer the call within 60 seconds, or the line remains busy during the three minute waiting time, the call will be transferred back to you.

If you pick up the receiver, you will be reconnected with the external communication partner. You can then place him in the waiting loop again. If you do not pick up the call within 60 seconds, the exchange line connection is disconnected completely (for example, if your line was busy even for a short time).

---

---

## Calling a Third Subscriber and Transferring to an Active Communication Partner

### Requirements:

- Knowledge of the telephone and its menu options
- Initiated query call

During a query call, proceed as described in the following.

1. If necessary, press the **▶ softkey** in front of the name or telephone number of the communication partner you would like to transfer.

The active communication partner is indicated by **▶** , and the waiting communication partner by **▶** .

2. Select **transf. act. call**
3. Press the **✓ softkey**.
4. Dial the telephone number of the subscriber to be called.

As soon as to the person being called picks up the receiver, conduct a third call.

---

**Important:** Enter telephone numbers exactly as when dialling, for example, always enter external telephone numbers with a leading exchange line access number.

---

5. Select **transfer**.

Both previously active communication partners are connected.

Then return to conducting an individual call with your first communication partner.

# Conference Calls

During a conference call, you are talking with two subscribers simultaneously.

---

## Initiating Conference Calls

*Requirements:*

- *Knowledge of the telephone and its menu options*
- *A query call you initiated yourself*

During a query call, proceed as described in the following.

1. Select **conference**.
2. Press the **✓ softkey**.  
You are making a conference call.

---

## Options during a Conference Call

The following actions are possible during a conference call:

### Initiating Splitting

When you end a conference call and would like to talk to each of the conference call partners separately one after the other, you can specifically put one of the conference call partners on hold in the background.

### Ending a Call with a Conference Call Partner

When you end a conference call and would like to continue talking with one of the conference call partners, you can specifically end the call with the other conference call partner separately. Of course, one of your conference call partners can simply hang up so that you can continue talking with the other conference call partner alone.

## Connecting both Conference Call Partners

If you would like to leave a conference call that you initiated yourself and your conference call partners would like to continue talking with each other, you can connect both parties.

## Ending a Conference Call Completely

If you initiated the conference call yourself, you can end the conference call completely.

---

## Initiating Splitting during a Conference Call

### *Requirements:*

- *Knowledge of the telephone and its menu options*
- *A conference call that you initiated yourself*

During a conference call, proceed as described in the following.

1. If necessary, press the **Ⓛ** **softkey** in front of the name or telephone number of the conference call partner with whom you would like to talk.
2. Select **splitting**.
3. Press the **✓** **softkey**.  
You are making a query call.

---

## Ending a Call with a Conference Call Partner

### *Requirements:*

- *Knowledge of the telephone and its menu options*
- *A conference call that you initiated yourself*

During a conference call, proceed as described in the following.

1. If necessary, press the **Ⓛ** **softkey** in front of the name or telephone number of the conference call partner with whom you would like to end the call.

2. Select **terminate**.
3. Press the **✓ softkey**.

You are conducting an one-on-one call with the other conference call partner.

---

## Connecting both Conference Call Partners

### *Requirements:*

- *Knowledge of the telephone and its menu options*
- *A conference call that you initiated yourself*
- *To connect two external communication partners, the following is required: Authorization in the PBX for **Transfer of external calls to external***

During a conference call, proceed as described in the following.

1. Select **conn. both calls**.
2. Press the **✓ softkey**.

Both conference call partners are connected with each other.

---

## Ending Conference Call Completely

### *Requirements:*

- *Knowledge of the telephone and its menu options*
- *A conference call that you initiated yourself*

During a conference call, proceed as described in the following.

- Hang up the receiver.

The conference call is disconnected completely.

## Hands-free Calling

During hands-free calling, the loudspeaker and microphone on the device are switched on. This option allows you to talk on the telephone even if you have no hands free. In addition, other people in the room can participate in the call.

---

### Initiating Call in Hands-free Calling Mode

*Requirements:*

– *Knowledge of the telephone and its menu options*

- When your phone rings, press the **hook key** or the **loudspeaker key** to initiate the call.

You are conducting a call in hands-free calling mode. The following symbol is shown in the display: 

- If you would like to call someone, dial the telephone number and press the **hook key** or the **loudspeaker key** to initiate the call.

You are conducting a call in hands-free calling mode. The following symbol is shown in the display: 

---

**Note:** During headset operation, you can only use the **loudspeaker key** since the **hook key** is being used to initiate and end the headset call.

---

---

### Ending up Call in Hands-free Calling Mode

*Requirements:*

– *Knowledge of the telephone and its menu options*

During hands-free calling mode, proceed as described in the following.

- Press the **hook key**.



## Switching on Hands-free Calling During a Call

*Requirements:*

- *Knowledge of the telephone and its menu options*

During a normal call or a call in loudspeaker listening mode using the receiver, proceed as described in the following.

- Press and hold the **loudspeaker key** for approx. 2 seconds. You can then hang up the receiver.

You are conducting a call in hands-free calling mode. The following symbol is shown in the display: 

---

## Switching off Hands-free Calling and Returning to Normal Calling

*Requirements:*

- *Knowledge of the telephone and its menu options*

During hands-free calling mode, proceed as described in the following.

- Pick up the receiver.

You are conducting a normal call.

- If you have already picked up the receiver or a headset is connected, press the **loudspeaker key**.

You are conducting a normal call or a headset call.

## Loudspeaker Listening

During loudspeaker listening, the receiver loudspeaker as well as the loudspeaker in the device are switched on. This allows other people in the room to listen in on the call. The call is continued using the receiver microphone (no hands-free calling).

---

### Switching on Loudspeaker Listening during a Call

*Requirements:*

– *Knowledge of the telephone and its menu options*

During a normal call using the receiver, proceed as described in the following.

- Press the **loudspeaker key**.

You are conducting a call in loudspeaker listening mode. The following symbol is shown in the display: 

---

### Switching off Loudspeaker Listening and Returning to Normal Calling

*Requirements:*

– *Knowledge of the telephone and its menu options*

During loudspeaker listening mode, proceed as described in the following.

- Press the **loudspeaker key**.

You are conducting a normal call.

## **Ending a Call in Loudspeaker Listening Mode**

*Requirements:*

- *Knowledge of the telephone and its menu options*

During loudspeaker listening mode, proceed as described in the following.

- Hang up the receiver.

# Headset Calls

A headset enables you to participate in calls when you have no hands free. This is a very useful feature, especially in certain professional areas (for example, in a call center).

---

## Initiating Headset Calls

*Requirements:*

- *Knowledge of the telephone and its menu options*
- *Headset operation enabled*

- When your telephone rings, press the **hook key** to initiate the call.  
You are making a headset call.
- If you would like to call someone, dial the telephone number and press the **hook key** to initiate the call.  
You are making a headset call.

---

**Note:** If a receiver is connected and picked up while the telephone is in the idle state, press the **hook key** or the **loudspeaker key** to initiate a headset call that also includes reception on the receiver (only for COMfortel 2500).

---

---

## Ending a Call in Headset Operation

*Requirements:*

- *Knowledge of the telephone and its menu options*
- *Headset operation enabled*

During a headset call or other call in headset operation, proceed as described in the following.

- Press the **hook key**.

---

## Initiating Listen in Function on Receiver (only for COMfortel 2500)

*Requirements:*

- *Knowledge of the telephone and its menu options*
- *Headset operation enabled*
- *Connected receiver*

During a headset call or other call in headset operation, proceed as described in the following.

- Pick up the receiver.  
You are making a headset call with an enabled receiver.
- If you have already picked up the receiver and hands-free calling is enabled, press the **loudspeaker key**.  
You are making a headset call with an enabled receiver.

---

## Ending Listen in Function on Receiver (only for COMfortel 2500)

*Requirements:*

- *Knowledge of the telephone and its menu options*
- *Headset operation enabled*
- *Connected receiver*

During a headset call with an enabled receiver, proceed as described in the following.

- Hang up the receiver.  
You are making a headset call.
- If you would like to participate with the others on the call, press the **loudspeaker key**.  
You are conducting a call in hands-free calling mode.

---

**Note:** If, during a headset call with an enabled receiver, you switch off headset operation, you can make a normal call using the receiver. You can only switch off headset operation during a call using a function key configured for this purpose.

---

# Telephone Book and Telephone Number Lists

This section describes the telephone book and the current caller and calls lists in the telephone.

## Topics

- [Telephone Book \(page 103\)](#)
- [Redial List \(page 127\)](#)
- [Calls List \(page 131\)](#)
- [Caller List \(page 137\)](#)

# Telephone Book

The telephone book is used for storing useful or frequently dialled telephone numbers along with the associated names. If a telephone number that is entered in the telephone book is transmitted during a call, the assigned name is displayed instead of the telephone number is displayed.

In the telephone book, entries (telephone numbers, macros and comments) can be stored. Up to four entries can be assigned to a name (contact).

In addition, internal telephone numbers (subscriber, groups, door, emergency call) as well as the telephone book/short-code numbers on the PBX are displayed. If one of these entries does not have a name, the system telephone generates a name for the telephone book (for example, int. TN45, KW-A 05306...). The entries cannot be changed in the telephone book of the system telephone; they can only be changed using the corresponding PC software on the PBX (internal telephone numbers with COMset; short-code numbers with COMtools). Each name (contact) is assigned only one telephone number entry. All of the contacts are displayed in alphabetical order.

---

## Opening the Telephone Book

Opening can be carried out as follows:

- Via the telephone menu

### *Requirements:*

– *Knowledge of the telephone and its menu options*

1. Press the **telephone book key**.
2. Scroll to the desired contact.

---

### **Note:**

In order to find the desired contact more quickly, you can enter the first letter into the keypad.

If there is no contact for the letter entered (display "no hits") or the contact in question is not present, you can delete the letters entered by pressing the **⬅ softkey** and enter another letter.

If there are multiple contacts for the beginning letter entered, you can enter additional letters to narrow the selection further.

The following information about the contact is shown on the display:

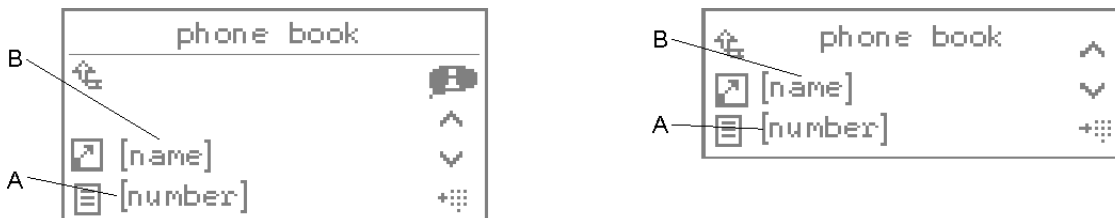

- A Telephone number (for multiple entries for this contact, the telephone number last dialled or entered)
- B Name (contact)

3. Select the desired option:

- Switches back into the idle state.
- Opens the expanded display.
- This opens the short overview.
- Indicates the available comments.
- Accepts the entry into dial preparation or into the telephone book, if applicable.





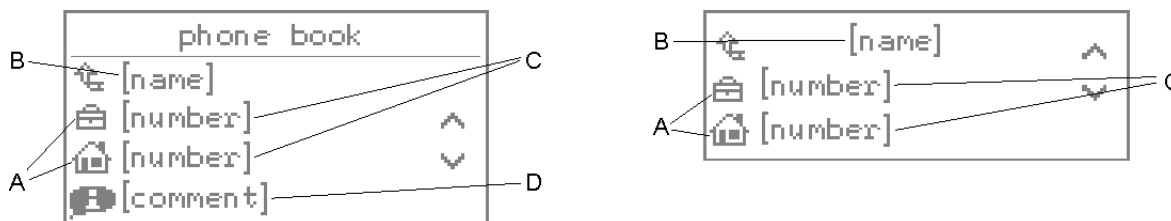

**Note:** If this is an internal telephone number or a short-code number on the PBX for the content displayed, the extended display is not available since these contacts can only contain a single telephone number.

If you have opened the extended display, the following information about the contact in the display is shown:



- A Type of entry: business telephone number () , private telephone number () , mobile telephone number () , call macro ()
- B Name (contact)
- C Existing entry
- D Existing comments



4. Select the desired option:
  -  Switches back into the list view.
  -  Expects the available business telephone number into the dial preparation.
  -  Expects the available private telephone number into the dial preparation.
  -  Expects the available mobile telephone number into the dial preparation.
  -  Expects the available call macro into the dial preparation.
  -  Indicates the available comments.
  -  Opens a contact for editing.
5. If you would like to leave the menu, press the **exit key**.

---

## Dialling from Telephone Book

Dialling can be carried out as follows:

- Via the telephone menu

### Dialling from Telephone Book via Telephone Menu

*Requirements:*

– *Knowledge of the telephone and its menu options*

1. Press the **telephone book key**.
2. Scroll to the desired contact or enter the first letter of the desired contact into the keypad.

The default telephone number is displayed. If there are multiple entries for a contact, this will be the telephone number last dialled or entered.
3. If you would like to dial a different number than the default telephone number associated with the contact, press the  **softkey** to open the expanded display. Then press the **softkey** in front of the desired telephone number.
4. Pick up the receiver or press the **hook key**.

---

**Note:** The telephone number now dialled becomes the default telephone number at the end of the call.

---

---

## Configuring a Contact

The telephone book of the COMfortel 1500 provides space for 400 entries, the telephone book of the COMfortel 2500 provides space for 800 entries (telephone numbers, macros and comments). Up to four entries can be assigned to a name (contact).

The configuration can be carried out as follows:

- Via COMfortel Set
- Via the telephone menu

### Configuring a Contact via COMfortel Set

*Requirements:*

– An open configuration and the required PIN, if necessary

1. Open the page **Telephone book** and click the **New** tab.
2. Enter the name of the contact in the **Name** entry field. The following entries are possible:
  - Up to 16 digits
  - Digits and characters
3. If you would like to be signaled by a specific ringer melody when a contact calls, select the ringer melody in question in the **Ringer melody** list field.

---

**Note:** If your telephone (COMfortel 2500 only) has an SD card on which your own ringer melodies are saved, click  to add ringer melodies to the **Ringer melody** list field. Your ringer melodies on the SD card are read out and added to the list field.

---

4. If you would like the answering machine to assign a certain kind of call acceptance to the contact, select one of the following options in the **TAM call acceptance** list field.
  - Standard:** When the contact calls, the call acceptance and announcement of the corresponding call type are used. The settings for this are configured under **Answering machine > Automatic**.
  - Announcement and recording:** The announcement selected for the contact is played back. After this, the caller can leave a message.

**Only announcement:** The announcement selected for the contact is played back; however, the caller can leave no message.

**No call acceptance:** A call from the contact is not accepted by the answering machine.

---

**Important:** A change in call acceptance/an announcement made here is only taken into account if special call acceptance/an announcement for telephone book contacts has been enabled.

---

5. In the **TAM call acceptance** list field, if you have one of the options **Only announcement** or **Announcement and recording**, select the announcement in the **Announcement** list field that will be used when accepting a call from the corresponding contact.

---

**Note:** If your telephone (COMfortel 2500 only) has an SD card on which your own announcements are saved, click  to add announcements to the **Announcement** list field. Your announcements on the SD card are read out and added to the list field.

---

6. In the **Kind** list field, select one of the following options:

**business:** Defines the telephone number to be entered as a business telephone number.

**mobile (business):** Defines the telephone number to be entered as a business mobile telephone number.

**private:** Defines the telephone number to be entered as a private telephone number.

**mobile (private):** Defines the telephone number to be entered as a private mobile telephone number.

7. In the **Type** list field, select one of the following options:

**internally:** Defines the telephone number to be entered as an internal telephone number.

**externally:** Defines the telephone number to be entered as an external telephone number.

8. In the **Telephone no** entry field, enter the telephone number. The following entries are possible:

Up to 40 digits

Digits and the characters \* and #

9. Click **Take over**.

---

**Note:** If you want to discard your entries of the new contact and create a another contact instead, click **New**. All entries of the corresponding contact which have not been saved yet are discarded.

---

*Further steps:*

- *Save your configuration before closing.*

### **Configuring a Contact via Telephone Menu**

*Requirements:*

- *Knowledge of the telephone and its menu options*

1. Press the **telephone book key**.

In the bottom line of the display, the number of existing entries and the maximum number of entries are displayed.

2. Press the  **softkey** in front of **new contact**.

3. Enter the name of the contact. The following entries are possible:

Up to 16 digits

Digits and characters

4. Press the  **softkey** to save the entry.

5. Select the desired option:

 Allows a business telephone number to be entered.

 Allows a private telephone number to be entered.

 Allows a mobile telephone number to be entered.

6. Enter the telephone number. The following entries are possible:

Up to 40 digits

Digits and the characters \* and #

---

**Important:** Enter telephone numbers exactly as when dialling, for example, always enter external telephone numbers with a leading exchange line access number. (exception: direct exchange access). The default exchange line access number on the PBX is "0" in the factory settings; however, this can be changed for several PBXs (see the PBX manual).

**Note:** While entering the telephone number, you can press the  **softkey** to change the kind of the telephone number (business, private, mobile).

---

7. Press the  **softkey** to save the entry.

The **edit contact** menu is opened. You can also enter additional telephone numbers and call macros as well as a comment (up to four entries). In addition, you can configure a specific ringer melody for calls from one of the corresponding telephone numbers.

8. If you would like to leave the menu, press the **exit key**.

If you would like to configure another contact without leaving the menu, press the  **softkey**.

---

**Note:** When entering multiple telephone numbers or call macros, the last entry configured or changed is used as the default telephone number.

---

---

## Editing a Contact

A contact that has already been configured, can be edited later.

Editing can be carried out as follows:

- Via COMfortel Set
- Via the telephone menu

### Editing Contact via COMfortel Set

*Requirements:*

– *An open configuration and the required PIN, if necessary*

1. Open the page **Telephone book** and click the **Edit** tab.
2. Click one of the following options to navigate to the contact that you would like to edit.

**Start of the list:** Jumps to the first contact in the telephone book.

**Previous contact:** Jumps to the previous contact in the telephone book.

**Next contact:** Jumps to the next contact in the telephone book.

**End of the list:** Jumps to the last contact in the telephone book.

---

**Note:**

Or you can double-click a telephone number for the contact to be edited directly on the page **Telephone book** (**Telephone book** tab). After this, the menu for editing the contacting question opens automatically.

Only contacts configured on the telephone can be edited or deleted. The internal telephone numbers as well as the telephone book/short-code numbers on the PBX can only be changed using the corresponding PC software or the web interface on the PBX (internal telephone numbers with COMset, short-code numbers with COMtools).

- 
3. If you would like to be signaled by a specific ringer melody when a contact calls, select the ringer melody in question in the **Ringer melody** list field.

---

**Note:** If your telephone (COMfortel 2500 only) has an SD card containing your own ringer melodies, click  to add ringer melodies to the **Ringer melody** list field. Your ringer melodies on the SD card are read out and added to the list field.

---

4. If you would like the answering machine to assign a certain kind of call acceptance to the contact, select one of the following options in the **TAM call acceptance** list field.

**Standard:** When the contact calls, the call acceptance and announcement of the corresponding call type are used. The settings for this are configured under **Answering machine > Automatic**.

**Announcement and recording:** The announcement selected for the contact is played back. After this, the caller can leave a message.

**Only announcement:** The announcement selected for the contact is played back; however, the caller can leave no message.

**No call acceptance:** A call from the contact is not accepted by the answering machine.

---

**Important:** A changed in call acceptance/an announcement made here is only taken into account if special call acceptance/an announcement for telephone book contacts has been enabled.

---

5. In the **TAM call acceptance** list field, if you have one of the options **Only announcement** or **Announcement and recording**, select the announcement in the **Announcement** list field that will be used when accepting a call from the corresponding contact.

---

**Note:** If your telephone (COMfortel 2500 only) has an SD card on which your own announcements are saved, click  to add announcements to the **Announcement** list field. Your announcements on the SD card are read out and added to the list field.

---

6. In the **Kind** list field, select one of the following options:

**business:** Defines the telephone number to be entered as a business telephone number.

**mobile (business):** Defines the telephone number to be entered as a business mobile telephone number.

**private:** Defines the telephone number to be entered as a private telephone number.

**mobile (private):** Defines the telephone number to be entered as a private mobile telephone number.

**macro:** Allows a macro to be entered.

**comment:** Allows a comment to be entered.

7. In the **Type** list field, select one of the following options:

**internally:** Defines the telephone number to be entered as an internal telephone number.

**externally:** Defines the telephone number to be entered as an external telephone number.

8. In the **Telephone no** entry field, enter the telephone number. The following entries are possible:

Up to 40 digits

Digits and the characters \* and #

*Further steps:*

– *Save your configuration before closing.*

## Editing Contact via Telephone Menu

### Requirements:

- Knowledge of the telephone and its menu options

1. Press the **telephone book key**.
2. Scroll to the desired contact or enter the first letter of the desired contact into the keypad.
3. Press the  **softkey** to open the expanded display.

---





**Note:** Only contacts configured on the telephone can be edited or deleted; this means that the expanded display is only available for such contacts. The internal telephone numbers as well as the telephone book/short-code numbers on the PBX can only be changed using the corresponding PC software or the web interface on the PBX (internal telephone numbers with COMset, short-code numbers with COMtools).

---

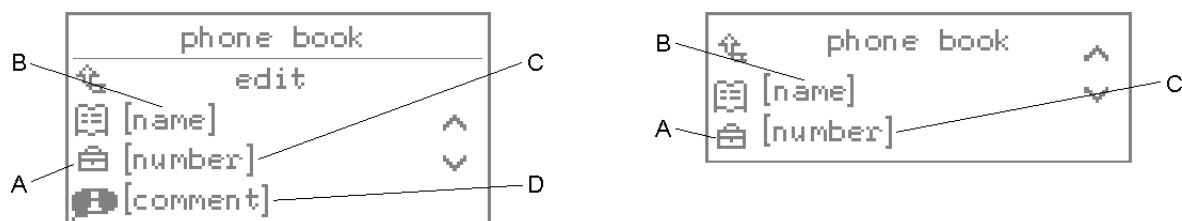
4. Press the  **softkey** to open the contact for editing.

The following information about the contact is shown on the display:







A Type of entry: business telephone number (  ), private telephone number (  ), mobile telephone number (  ), call macro (  )

B Name (contact)





C Existing entry

D Existing comments

5. Select the desired option:

-  Allows the name to be changed.
-  Allows the existing business telephone number to be changed.
-  Allows the existing private telephone number to be changed.
-  Allows the existing mobile telephone number to be changed.
-  Enables the existing call macro to be changed.



-  Enables a comment to be entered and changed.
-  Enables the ringer rhythm that signals a call from this contact to be selected or changed.
-  Enables call acceptance on the answering machine to be changed and the announcement to be selected that is used when accepting a call from the corresponding contact.
-  Enables an additional telephone number or call macro to be entered.
-  Enables deleting the contact.

---

### **Important:**

Enter telephone numbers exactly as when dialling, for example, always enter external telephone numbers with a leading exchange line access number. (exception: direct exchange access). The default exchange line access number on the PBX is "0" in the factory settings; however, this can be changed for several PBXs (see the PBX manual).

A changed in call acceptance/an announcement made here is only taken into account if special call acceptance/an announcement for telephone book contacts has been enabled.

**Note:** When entering multiple telephone numbers or call macros, the last entry configured or changed is used as the default telephone number.

---

6. If you would like to leave the menu, press the **exit key**.

---

## **Deleting a Contact**

Deleting can be carried out as follows:

- Via COMfortel Set
- Via the telephone menu

### **Deleting a Contact via COMfortel Set**

*Requirements:*

- *An open configuration and the required PIN, if necessary*

1. Open the page **Telephone book** and click the **Telephone book** tab.
2. Click the line with the contact to be deleted.
3. Right-click the line with the contact to be deleted and click **Delete rows**.

*Further steps:*

- *Save your configuration before closing.*

### **Deleting a Contact via Telephone Menu**

*Requirements:*



- *Knowledge of the telephone and its menu options*

1. Press the **telephone book key**.
2. Scroll to the desired contact or enter the first letter of the desired contact into the keypad.
3. Press the  **softkey** to open the expanded display.

---

**Note:** Only contacts configured on the telephone can be edited or deleted; this means that the expanded display is only available for such contacts. The internal telephone numbers as well as the telephone book/short-code numbers on the PBX can only be changed using the corresponding PC software or the web interface on the PBX (internal telephone numbers with COMset, short-code numbers with COMtools).

---

4. Press the  **softkey**.
5. Press the  **softkey**.
6. Press the  **softkey** to confirm the action.
7. If you would like to leave the menu, press the **exit key**.

## Entering Comments for a Contact

The comment function is used for entering more detailed information about a contact, for example, the reachability or the name of the contact partner for a company.

The entry can be made as follows:

- Via COMfortel Set
- Via the telephone menu

### Entering Comments for a Contact via COMfortel Set

*Requirements:*

– *An open configuration and the required PIN, if necessary*

1. Open a contact for editing or create a new contact.
2. In the **Kind** list field, select the **Comment** option.
3. Enter the comment in the **Telephone number** entry field. The following entries are possible:

Up to 40 digits

Digits and characters

*Further steps:*

– *Save your configuration before closing.*

### Entering Comments for a Contact via Telephone Menu

*Requirements:*

– *Knowledge of the telephone and its menu options*

1. Open a contact for editing.
2. Press the  **softkey**.

3. Enter the comment. The following entries are possible:

Up to 40 digits

Digits and characters

4. Press the  **softkey** to save the entry.

---

**Note:** When scrolling through the telephone book, you can see whether a contact contains a comment or not. Press the  **softkey** to display this.

---

---

## Configuring a Call Macro

A call macro can contain numbers as well as certain control characters. This enables you, for example, to query an answering machine.

The configuration can be carried out as follows:

- Via COMfortel Set
- Via the telephone menu

### Configuring Call Macro via COMfortel Set

*Requirements:*

– An open configuration and the required PIN, if necessary

1. Open a contact for editing or create a new contact.
2. In the **Kind** list field, select the **macro** option.
3. Enter the call macro in the **Telephone number** entry field. The following entries are possible:

Up to 40 digits

Digits and the characters \* and #

The commands listed at the end.

-: Waiting time/pause time of 1 second

=: Waiting time/pause time of 2 seconds

<: Waiting time/pause time of 4 seconds

**W**: Wait for a connection

**H**: Replace/pick up receiver





*Further steps:*

– *Save your configuration before closing.*

### **Configuring a Call Macro via Telephone Menu**

*Requirements:*

– *Knowledge of the telephone and its menu options*

1. Open a contact for editing or create a new contact.
2. Press the  **softkey** (not applicable when configuring a new contact).
3. Press the  **softkey**.
4. Enter a call macro. The following entries are possible:
  - Up to 40 digits
  - Digits and the characters \* and #
  - Commands
  - a) Press the  **softkey** to add a command.
  - b) Select the desired option:
    - pause: 1 second**: Inserts a pause of one second.
    - pause: 2 seconds**: Inserts a pause of two seconds.
    - pause: 4 seconds**: Inserts a pause of four seconds.
    - wait for connect**: Inserts a pause that lasts until the connection is established. (If no connection is possible, the macro ends.)
    - repl/lift hands**: Ends the connection or initiates, it depending on the status.
5. Press the  **softkey** to save the entry.

---

**Important:** Enter telephone numbers exactly as when dialling, for example, always enter external telephone numbers with a leading exchange line access number. (exception: direct exchange access). The default exchange line access number on the PBX is "0" in the factory settings; however, this can be changed for several PBXs (see the PBX manual).

---

---

## Switching Specific Call Acceptance/Announcement for Telephone Book Contacts On/Off

If the specific call acceptance/announcement for telephone book contact is switched on, the settings configured for call acceptance and announcement for the telephone book contacts are taken into account.

The call acceptance/announcement for the contact applies to each of the contact's four possible telephone numbers.

Switching this on/off can be done as follows:

- Via COMfortel Set
- Via the telephone menu

### Switching Specific Call Acceptance/Announcement for Telephone Book Contacts On/Off via COMfortel Set

*Requirements:*

– *An open configuration and the required PIN, if necessary*

1. Open the page **Answering machine > Global**.
2. Select or clear the **Specific announcements for telephone book entries** check box.
  - Enables the specific call acceptance/announcement for telephone book contacts.
  - Disables the specific call acceptance/announcement for telephone book contacts.

*Further steps:*

– *Save your configuration before closing.*

## **Switching Specific Call Acceptance/Announcement for Telephone Book Contacts On/Off via Telephone Menu**

### *Requirements:*

– *Knowledge of the telephone and its menu options and the required PIN, if necessary*

1. Press the **menu key** and open the menu **answer.machine > settings > ph.book announc..**
2. Select or clear the **ph.book announc.** check box.
  - Enables the specific call acceptance/announcement for telephone book contacts.
  - Disables the specific call acceptance/announcement for telephone book contacts.
3. Press the **✓ softkey** to accept the setting.

---

## **Accepting Telephone Numbers from Dial Preparation**

If you would like to enter telephone numbers from different lists (caller, calls, redial list) into the telephone book, you can accept them directly from dial preparation.

Accepting can be carried out as follows:







- Via the telephone menu

### *Requirements:*

– *Knowledge of the telephone and its menu options*

After accepting or entering a telephone number in dial preparation, proceed as described in the following.

1. Press the **☰ softkey** in order to accept the telephone number into the telephone book.
2. Enter the name of the contact. The following entries are possible:
  - Up to 16 digits
  - Digits and characters

3. Press the  **softkey** to save the entry.
4. Select the desired option:
  -  Enters the telephone number as a business telephone number.
  -  Enters the telephone number as a private telephone number.
  -  Enters the telephone number as a mobile telephone number.
  -  Enters the telephone number as a call macro.
5. Change the telephone number, if necessary.
6. Press the  **softkey** to save the entry.

---

## Accepting Telephone Numbers into Other Menus

Before entering a telephone number in a menu (for example, when configuring a speed dialling key, a scheduled call with dial preparation or call forwarding for subscribers), you can select the desired telephone numbers in the telephone book. If you have already entered any codes, the telephone number from this telephone book entry is added at the end.

Accepting can be carried out as follows:



- Via the telephone menu

### *Requirements:*

– *Knowledge of the telephone and its menu options*

After opening a menu for entering telephone numbers, proceed as described in the following.

1. Press the **telephone book key**.
2. Scroll to the desired contact or enter the first letter of the desired contact into the keypad.

The default telephone number is displayed. If there are multiple entries for a contact, this will be the telephone number last dialled or entered.
3. Press the  **softkey** to accept the telephone number in the menu for the telephone number entry.
4. Press the  **softkey** to save the entry.



---

**Note:** The name is also accepted – if it is needed in the menu for the function in question.

---

---

## Configuring Displayed Telephone Number Range for Telephone Book

If you would like to prevent too many entries from being displayed in the telephone book, you can restrict the display of the various telephone number ranges. The following areas can be selected:

- Emergency numbers (emergency numbers configured in the PBX)
- Internal telephone numbers (internal telephone numbers configured in the PBX)
- PBX telephone book (telephone book entries/short-code numbers configured in the PBX)
- Local telephone book (telephone book entries you have configured in the telephone yourself)

The configuration can be made as follows:

- Via COMfortel Set
- Via the telephone menu

### **Configuring Displayed Telephone Number Range for Telephone Book via COMfortel Set**

*Requirements:*

– *An open configuration and the required PIN, if necessary*

1. Open the page **Settings/functions > Lists**.
2. Under **Telephone book**, select or clear the check box for the number ranges listed on the tab.
  - The telephone number range in question is displayed in the telephone book.
  - The telephone number range in question is not displayed in the telephone book.

*Further steps:*

– *Save your configuration before closing.*

## Configuring Displayed Telephone Number Range for Telephone Book via Telephone Menu

### *Requirements:*

- *Knowledge of the telephone, its menu options and the required PIN, if necessary*

1. Press the **menu key** and open the menu **settings > lists**.
2. Select **phone book**.

---

**Note:** To open this menu, you can also press the **telephone book key** for approx. 3 seconds in the idle state of the telephone.

---

3. Select or clear the check box for the telephone number ranges on the list.
  - The telephone number range in question is displayed in the telephone book.
  - The telephone number range in question is not displayed in the telephone book.
4. Press the **✓ softkey** to accept the setting.

---

## Importing the Telephone Book

This function enables you to import a telephone book that had previously been exported out of another system telephone into the telephone book on an identical model. Only the names and telephone numbers of contacts are imported. Existing comments and call macros are not imported.

The import can be carried out as follows:

- Via COMfortel Set

### *Requirements:*

- *An open configuration and the required PIN, if necessary*
- *A file (\*.csv) saved on the hard drive, data arranged in rows and separated (semicolons, comma, tabs or your own character)*

1. Open the page **Telephone book** and click the **Import/export** tab.

2. Click **Import**.

A dialogue for selecting the separator character opens.

3. Select the separator to be used to separate the entries into individual columns in the file to be imported and click **OK**.

A dialogue for selecting the columns to be imported opens.

4. Switch in the directory where the file is located. Select the file to be imported.

5. Arrange how the individual pieces of data should be distributed across the existing table columns.

6. In the lower list field, select one of the following options:

**unsynchronized:** All previous entries remain unchanged. The data for the file to be imported is appended to the telephone book unverified.

**Synchronize after -Name:** If the telephone book already contains a name that also occurs in the file to be imported, this data set is not imported. New names are appended to the telephone book along with the corresponding data (max. four telephone numbers).

**Synchronize after -Telephone number/Text x:** If the selected column in the telephone book (Telephone number/Text x) already contains an entry that also occurs in the assigned area of the file to be imported, this data set is not imported. For new telephone numbers, a new contact is created in the telephone book with the corresponding name.

7. Click **OK**.

*Further steps:*

– *Save your configuration before closing.*

---

## Importing Outlook Contacts

This function enables Outlook data (2002, 2003, XP, 2007) to be imported.

The import can be carried out as follows:

- Via COMfortel Set

*Requirements:*

- An open configuration and the required PIN, if necessary
- Contacts created in Outlook (2002, 2003, XP, 2007)

1. Open the page **Telephone book** and click the **Import/export** tab.
2. Click **Import Outlook contacts**.
3. In the **Country code (0049)** entry field, enter your own country code.
4. In the **Replace the country code at the beginning of the number by** entry field, enter the code that should replace your own country code during import.
5. Under **Outlook folders to be imported**, click **Select**. Select the folder to be imported and click **Open**.
6. In the **Name allocation in the telephone book** list field, select one of the following options:
  - Last name, first name:** The first and last names saved in Outlook are accepted into COMfortel Set in a last name, first name format.
  - Last name first name:** The first and last names saved in Outlook are accepted into COMfortel Set in a last name first name format.
  - First name last name:** The first and last names saved in Outlook are accepted into COMfortel Set in a first name last name format.
7. Under **Outlook categories to be imported**, select or clear the check box for the Outlook categories to be imported.
  - The Outlook category is imported.
  - The Outlook category is not imported.

If you would like to select the check boxes for all the Outlook categories at once, under **Category selection**, click **all**.

If you would like to clear the check boxes for all the Outlook categories at once, under **Category selection**, click **none**.
8. Click **Import**.
9. Assign which data should be imported and how the individual pieces of data should be distributed across the existing table columns.

10. In the lower list field, select one of the following options:

**unsynchronized:** All previous entries remain unchanged. The data for the contacts to be imported is appended to the telephone book unverified.

**Synchronize according to -Last name, first name:** If the telephone book already contains a name that also occurs in the contacts to be imported, this data set is not imported. New names are appended to the telephone book along with the corresponding data (max. four telephone numbers).

**Synchronize after -Telephone number/text:** If the selected column in the telephone book (Telephone number/text x) already contains an entry that also occurs in the assigned area of the contacts to be imported, this data set is not imported. For new telephone numbers, a new contact is created in the telephone book with the corresponding name.

11. Click **OK**.

*Further steps:*

– *Save your configuration before closing.*

---

## Exporting the Telephone Book

You can export the telephone book as a file (\*.csv) using this function. This file can then be further processed with other programs which provide CSV import options (for example, MS Excel).

The export can be carried out as follows:

- Via COMfortel Set

*Requirements:*

- *An open configuration and the required PIN, if necessary*
- *Existing entries in the telephone book*

1. Open the page **Telephone book** and click the **Import/export** tab.
2. Click **Export**.

A dialogue for selecting the separator character opens.

3. Select the desired separator to be used to separate each entry into individual columns and click **OK**.

A dialogue for selecting the columns to be exported opens.

4. Select the desired columns and click **OK**.

A file location dialogue opens.

5. Select the directory in which you would like to save the file.

6. Enter a filename with the ending .csv and click **Save** (this text is dependent on the operating system used).

---

**Note:** Under **Name**, if, for example, you use characters that can also be recognised as control characters during an export to CSV (for example, a semicolon), these characters will be accepted in the file unverified. This can lead to problems when reimporting the edited files.

---

## Redial List

The last 30 telephone numbers dialled are saved in the redial list. For more than 30 telephone numbers dialled, the oldest entry is overwritten. The telephone numbers are saved along with number of dialling operations, date and time of dialling (for multiple dialling operations, the date/time of the last attempt).

---

### Opening the Redial List

Opening can be carried out as follows:

- Via the telephone menu

#### Requirements:

- Knowledge of the telephone and its menu options
- At least one entry in the list

#### 1. Press the **redial key**.

The redial list is now opened. The entry with the telephone number dialled previously is displayed.

The following information about the entry is shown on the display:

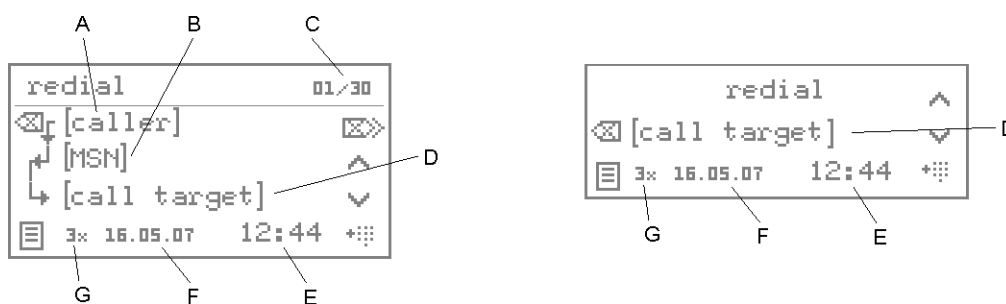

A Caller

B Outbound MSN used for the call

---

**Important:** Only available for operation on the PBXs COMpact 3000, COMpact 5010 VoIP, COMpact 5020 VoIP, COMmander Basic.2 and COMmander Business.

---

C Consecutive number of entries/number of existing entries

---

**Note:** The latest entry is displayed with consecutive number 1.

---

D Call target

E Time of last attempt

F Date of last attempt

G Number of attempts

2. Select the desired option:

- ☒ Deletes the entry shown.
- ☒ Deletes the callback shown (function only available for operation on the PBXs COMpact 5010 VoIP, COMpact 5020 VoIP, COMmander Basic.2 and COMmander Business).
- ☒ Deletes the entire redial list.
- ☒ This opens the short overview.
- ^ Scrolls to the next entry.
- v Scrolls to the previous entry.
- +☒ Accepts the entry into dial preparation or into the telephone book, if applicable.

---

## Dialling from Redial List

Dialling can be carried out as follows:

- Via the telephone menu

### *Requirements:*

– *Knowledge of the telephone and its menu options*

1. Open the redial list.

The last telephone number dialled is displayed.

---

**Note:** If you have already picked up the receiver when you press the **redial key**, the telephone number dialled last is immediately dialled.

---



2. Scroll to the desired entry or press the **redial key** several times.
3. Pick up the receiver or press the **hook key**.

The subscriber is called.

---

**Note:** If you would like to exit the menu without dialling the telephone number displayed, press the **exit key**.

---

---

## Deleting Entries in Redial List

Deleting can be carried out as follows:

- Via the telephone menu

### *Requirements:*

– *Knowledge of the telephone and its menu options*

1. Open the redial list.

The last telephone number dialled is displayed.

2. Press the  **softkey** to delete the entry shown.

---

**Note:** In order to delete the entire redial list, press the  **softkey** and confirm the action. Or you can delete the entire redial list via the function menu using **functions > delete data > redial list**.

---

---

## Configuring Calls to be Recorded for Redial List

If you would like to prevent too many entries from being entered in the redial list, you can configure the list in relation to the calls to be recorded. The following calls can be selected:

- External calls

- Internal calls
- Door terminal calls
- Other calls

The configuration can be made as follows:

- Via COMfortel Set
- Via the telephone menu

### **Configuring Calls to be Recorded for Redial List via COMfortel Set**

*Requirements:*

– *An open configuration and the required PIN, if necessary*

1. Open the page **Settings/functions > Lists**.
2. Under **Redial list**, select or clear the check box for the types of call listed on the tab.
  - The call type in question is entered on the redial list.
  - The call type in question is not entered on the redial list.

*Further steps:*

– *Save your configuration before closing.*

### **Configuring Calls to be Recorded for Redial List via Telephone Menu**

*Requirements:*

– *Knowledge of the telephone and its menu options and the required PIN, if necessary*

1. Press the **menu key** and open the menu **settings > lists**
2. Select **redial list**.
3. Select or clear the check box for the types of call entered on the list.
  - The call type in question is entered on the redial list.
  - The call type in question is not entered on the redial list.
4. Press the **✓ softkey** to accept the setting.

## Calls List

The calls made (incoming and outgoing) are saved in the calls list of the telephone along with the telephone number of the communication partner as well as date, time and duration of the call. A maximum of 30 calls can be saved. For more than 30 calls, the oldest entry is overwritten. A previous communication partner can be called directly from the calls list.

---

### Opening the Calls List

Opening can be carried out as follows:

- Via the telephone menu

#### Requirements:

- Knowledge of the telephone and its menu options and the required PIN, if necessary
- At least one entry in the list

You can open the calls list by pressing a function key configured for this purpose.

In addition, you can also open the calls list via the telephone menu **Functions > calls list**.

Or, proceed as described in the following.

1. Press the **softkey** to change from the idle state into the second level.
2. Select **calls list**.

The call conducted last is displayed.

The following information about the entry is shown on the display:

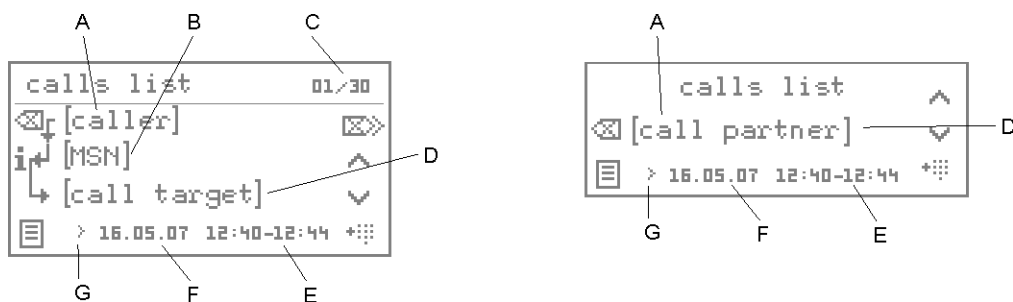







A Caller (communication partner)

- B Outbound MSN used for an external call, external call target/exchange line number called (for an external inbound call) or project number
- C Consecutive number of entries/number of existing entries

---

**Note:** The latest entry is displayed with consecutive number 1.

---

- D Call target (communication partner)
  - E Time of the call
  - F Date of the call
  - G Type of call: external outgoing (→), external incoming (←), internal outgoing (▶) and internal incoming (◀)
3. Select the desired option:
-  Deletes the entry shown.
  -  Deletes the entire calls list.
  -  Indicates additional information, if available.
  -  This opens the short overview.
  -  Scrolls to the next entry.
  -  Scrolls to the previous entry.
  -  Accepts the entry into dial preparation or into the telephone book, if applicable.

---

## Dialling from Calls List

Dialling can be carried out as follows:

- Via the telephone menu

### *Requirements:*

– *Knowledge of the telephone and its menu options and the required PIN, if necessary*

1. Open the calls list.  
The call conducted last is displayed.
2. Scroll to the desired entry.

3. Pick up the receiver or press the **hook key**.

The subscriber is called.

---

**Note:** If you would like to exit the menu without dialling the telephone number entered, press the **exit key**.

---

---

## Deleting Entries in Calls List

Deleting can be carried out as follows:

- Via the telephone menu

*Requirements:*

– *Knowledge of the telephone and its menu options and the required PIN, if necessary*

1. Open the calls list.

The call conducted last is displayed.

2. Press the  **softkey** to delete the entry shown.

---

**Note:** In order to delete the entire calls list, press the  **softkey** and confirm the action. Or you can delete the entire calls list via the function menu using **Functions > delete data > calls list**.

---

---

## Configuring and Operating Function Key for Calls List

Press the key while the telephone is in the idle state to open the calls list.

**LED signalling next to the key:**

None

The configuration can be carried out as follows:

- Via COMfortel Set
- Via the telephone menu

### **Configuring Function Key for Calls List via COMfortel Set**

*Requirements:*

– An open configuration and the required PIN, if necessary

1. Open the page **Function keys > Assign function keys**.
2. Only available in installed extension modules: In the telephone displayed at the top left, click the key group in which you would like to define keys.
3. Click one of the following tabs:
  - Level 1:** Keys are defined on the first key level.
  - Level 2:** Keys are defined on the second key level.
4. Right-click the function key you want to assign.  
A function selection dialogue opens.
5. Select the **Calls list** function.  
The current settings for defining the key are displayed.
6. In the **Key name** entry field, enter a name for the key. The following entries are possible:
  - Up to 16 digits
  - Digits and characters

Clicking  automatically enters the default name in the entry field.

---

**Note:** The key name is used for printing the label.

---

*Further steps:*

– Save your configuration before closing.

## **Configuring Function Key for Calls List via Telephone Menu**

### *Requirements:*

– *Knowledge of the telephone and its menu options and the required PIN, if necessary*

1. Press the **menu key** and open the **define keys** menu.
2. Press the **function key** that you would like to define.
3. Select the desired option:
  - first level:** Keys are defined on the first key level.
  - second level:** Keys are defined on the second key level.The list of available functions is displayed.
4. Select the **calls list** function.
5. Press the **✓ softkey** to accept the setting.

---

## **Configuring Calls to be Recorded for Calls List**

If you would like to prevent too many entries from being entered in the calls list, you can configure the calls list in relation to the calls to be recorded. The following calls can be selected:

- External calls without telephone numbers
- External calls with telephone numbers
- Internal calls
- Alarm calls
- Door terminal calls
- Other calls

The configuration can be made as follows:

- Via COMfortel Set
- Via the telephone menu

### **Configuring Calls to be Recorded for Calls List via COMfortel Set**

*Requirements:*

– An open configuration and the required PIN, if necessary

1. Open the page **Settings/functions > Lists**.
2. Under **Calls list**, select or clear the check box for the types of calls listed on the tab.
  - The call type in question is entered in the calls list.
  - The call type in question is not entered in the calls list.

*Further steps:*

– Save your configuration before closing.

### **Configuring Calls to be Recorded for Calls List via Telephone Menu**

*Requirements:*

– Knowledge of the telephone and its menu options and the required PIN, if necessary

1. Press the **menu key** and open the menu **settings > lists**.
2. Select **calls list**.
3. Select or clear the check box for the types of calls entered on the list.
  - The call type in question is entered in the calls list.
  - The call type in question is not entered in the calls list.
4. Press the **✓ softkey** to accept the setting.



## Caller List

Telephone numbers of calls not accepted are saved in the caller list of the telephone, along with the number of call attempts as well as the date and time of the call (for multiple call attempts, date/time of the last call attempt). A maximum of 30 telephone numbers can be saved. If more than 30 calls from various telephone numbers come in, the oldest entry is overwritten.

A caller be called back directly from the caller list.

The LED above the message key indicates whether entries are present on the caller list.

---

### Opening the Caller List

Opening can be carried out as follows:

- Via the telephone menu

#### *Requirements:*

- *Knowledge of the telephone and its menu options and the required PIN, if necessary*
- *At least one entry in the list*

You can open the caller list by pressing a **function key** configured for this purpose.

In addition, you can also open the caller list via the telephone menu **functions > caller list**.

Or, proceed as described in the following.

1. Press the **message key**.

The available lists are displayed. To the right next to the selection of lists, the respective numbers of existing recordings and calls are displayed.

2. Select **caller list** to open the caller list (this is skipped if the other lists are empty or not available).

The last received call is displayed.

The following information about the entry is shown on the display:

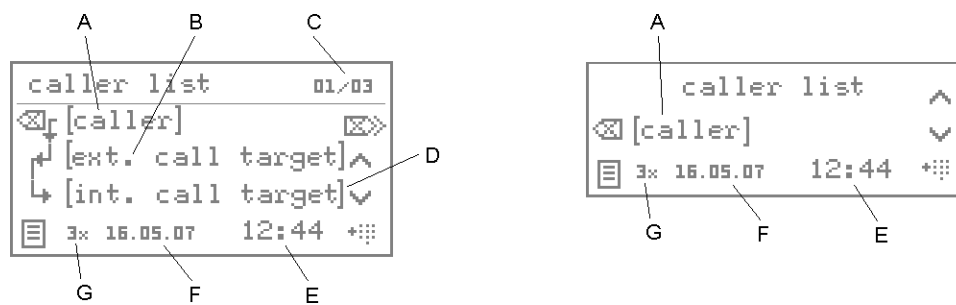

- A Caller
- B External call target/exchange line number called (for an external call)
- C Consecutive number of entries/number of existing entries

---

**Note:** The latest entry is displayed with consecutive number 1.

---

- D Internal call target
- E Time of last attempt
- F Date of last attempt
- G Number of attempts

3. Select the desired option:

- ☒ Deletes the entry shown.
- ☒ Deletes the entire caller list.
- ☒ This opens the short overview.
- ^ Scrolls to the next entry.
- ∨ Scrolls to the previous entry.
- +☒ Accepts the entry into dial preparation or into the telephone book, if applicable.

---

## Dialling from Caller List

Dialling can be carried out as follows:

- Via the telephone menu

**Requirements:**

- Knowledge of the telephone and its menu options and the required PIN, if necessary

1. Open the caller list.

The last incoming call is displayed.

2. Scroll to the desired entry or press the **message key** several times.

3. Pick up the receiver or press the **hook key**.

The subscriber is called.

---

**Note:**

If you would like to exit the menu without dialling the telephone number displayed, press the **exit key**.

As soon as a connection (incoming or outgoing) has been established with the caller, the telephone number in question is deleted from the caller list. Only when operated on the PBXs COMpact 5010 VoIP, COMpact 5020 VoIP, COMmander Basic.2 and COMmander Business: If this is a group called, the telephone number is also deleted from the caller lists of the other members of the group. (Can be configured using the configuration manager on the PBX. Group-wide deletion does not occur if the person calling back has already deleted his caller list or has been called again by the same caller on his subscriber telephone number.)

---

---

## Deleting Entries in Caller List

Deleting can be carried out as follows:

- Via the telephone menu

*Requirements:*

– *Knowledge of the telephone and its menu options and the required PIN, if necessary*

1. Open the caller list.

The last incoming call is displayed.

2. Press the  **softkey** to delete the entry shown.

---

**Note:** In order to delete the entire caller list, press the  **softkey** and confirm the action. Or you can delete the entire caller list via the function menu using **Functions > delete data > caller list**.

---

---

## Configuring and Operating Function Key for Caller Lists

Press the key while the telephone is in the idle state to open the caller list.

In addition, when functions are defined on the first key level, the status of the caller list is indicated by the corresponding LED.

### LED signalling next to the key:

Green	There are no new entries. All of the entries in the list have been viewed, but have not yet been deleted.
Green (blinking)	The list contains new entries that have not yet been viewed.
off	The list is empty.

The configuration can be carried out as follows:

- Via COMfortel Set
- Via the telephone menu

### Configuring Function Key for Caller List via COMfortel Set

#### *Requirements:*

– An open configuration and the required PIN, if necessary

1. Open the page **Function keys > Assign function keys**.
2. Only available in installed extension modules: In the telephone displayed at the top left, click the key group in which you would like to define keys.

3. Click one of the following tabs:
  - Level 1:** Keys are defined on the first key level.
  - Level 2:** Keys are defined on the second key level.
4. Right-click the function key you want to assign.  
A function selection dialogue opens.
5. Select the **Caller list** function.  
The current settings for defining the key are displayed.
6. In the **Key name** entry field, enter a name for the key. The following entries are possible:
  - Up to 16 digits
  - Digits and characters

Clicking  automatically enters the default name in the entry field.

---

**Note:** The key name is used for printing the label.

---

*Further steps:*

- *Save your configuration before closing.*

### **Configuring Function Key for Caller List via Telephone Menu**

*Requirements:*

- *Knowledge of the telephone and its menu options and the required PIN, if necessary*

1. Press the **menu key** and open the **define keys** menu.
2. Press the **function key** that you would like to define.
3. Select the desired option:
  - first level:** Keys are defined on the first key level.
  - second level:** Keys are defined on the second key level.The list of available functions is displayed.
4. Select the **caller list** function.

5. Press the  **softkey** to accept the setting.

---

## Configuring Calls to be Recorded for Caller List

If you would like to prevent too many entries from being entered in the caller list, you can configure the list in relation to the calls to be recorded. The following calls can be selected:

- External calls without telephone numbers
- External calls with telephone numbers
- Internal calls
- Alarm calls
- Door terminal calls
- Calls accepted by another subscriber
- Other calls

The configuration can be made as follows:

- Via COMfortel Set
- Via the telephone menu

### Configuring Calls to be Recorded for Caller List via COMfortel Set

*Requirements:*

– *An open configuration and the required PIN, if necessary*

1. Open the page **Settings/functions > Lists**.
2. Under **Caller list**, select or clear the check box for the types of call listed on the tab.
  - The call type in question is entered on the caller list.
  - The call type in question is not entered on the caller list.

*Further steps:*

– *Save your configuration before closing.*

## **Configuring Calls to be Recorded for Caller List via Telephone Menu**

### *Requirements:*

– *Knowledge of the telephone and its menu options and the required PIN, if necessary*

1. Press the **menu key** and open the menu **settings > lists**.
2. Select **caller list**.
3. Select or clear the check box for the types of call entered on the list.
  - The call type in question is entered on the caller list.
  - The call type in question is not entered on the caller list.
4. Press the **✓ softkey** to accept the setting.

---

## **Configuring the LED Message Key**

While in the idle state, the LED above the message key indicates the state of the list/s available over the message key.

- LED is flashing: The list contains new entries that have not yet been viewed.
- LED lights up: There are no new entries. All of the entries in the list have been viewed, but have not yet been deleted.

If the LED signalling is disruptive or bothersome, it can be switched off.

The configuration can be carried out as follows:

- Via COMfortel Set
- Via the telephone menu

## **Configuring LED Message Key via COMfortel Set**

### *Requirements:*

– *An open configuration and the required PIN, if necessary*

1. Open the page **Settings/functions > Signalling/ringer**.

2. In the **Message LED** list field, select one of the following options:

**Flashing/always on:** Switches on LED signalling.

**Flashing/off:** Switches on LED signalling only for new entries that have not yet been viewed.

**Always off:** Switches off LED signalling.

*Further steps:*

- *Save your configuration before closing.*

### **Configuring LED Message Key via Telephone Menu**

*Requirements:*

- *Knowledge of the telephone, its menu options and the required PIN, if necessary*

1. Press the **menu key** and open the menu **settings > signalling > message LED**.

The ● icon indicates the current setting.

2. Select the desired option:

**flashing + on:** Switches on LED signalling.

**flashing only:** Switches on LED signalling only for new entries that have not yet been viewed.

**LED always off:** Switches off LED signalling.



# Configuring and Operating Functions

This section describes how to set up and operate the functions on your telephone. Descriptions are given on what the functions do, how to operate them and – if possible – how to define these functions on programmable function keys.

In most cases, configuration can be carried out in two different ways:

- Configuration via the telephone menu
- Configuration via COMfortel Set

## Topics

- [Automatic Call Acceptance \(page 146\)](#)
- [Boss/Secretary Function \(page 152\)](#)
- [Call Deblocker \(Incoming\) – VIP Numbers \(page 162\)](#)
- [Call Forwarding \(page 166\)](#)
- [Call Restrictor \(Incoming\) – Robinson Numbers \(page 189\)](#)
- [Call Waiting \(page 193\)](#)
- [Configuration Switchover \(page 198\)](#)
- [Do-not-disturb \(page 203\)](#)
- [Door Functions \(page 209\)](#)
- [Exchange Line Transfer \(page 216\)](#)
- [Follow me \(page 219\)](#)
- [Group Functions \(page 223\)](#)
- [Hotel Function \(page 235\)](#)
- [InterCom Announcement/Handsfree \(page 251\)](#)
- [Loudspeaker Audio Out \(page 263\)](#)
- [Macro \(page 267\)](#)
- [Memo \(page 273\)](#)
- [Phone Lock \(page 275\)](#)
- [Pickup \(page 279\)](#)
- [Power Dialling \(page 283\)](#)
- [Power Save Mode \(page 286\)](#)
- [Project Assignment \(page 292\)](#)
- [Relays \(page 301\)](#)
- [Room Monitoring \(page 305\)](#)
- [Scheduled Call \(page 308\)](#)
- [Speed Dialling \(page 316\)](#)
- [Targeted Exchange Line Access \(page 323\)](#)
- [Targeted VoIP Access Point \(page 333\)](#)
- [Text before Answering \(page 337\)](#)
- [Voicemail Center 461/461.2 \(page 345\)](#)
- [Waiting Field Function \(page 353\)](#)

# Automatic Call Acceptance

Automatic call acceptance facilitates headset operation at call centers or on hotlines. An incoming call is automatically accepted after a configured amount of time. Call acceptance is signalled by an attention tone.

---

## Switching Automatic Call Acceptance On/Off

Switching this on/off can be done as follows:

- Via the telephone menu

### *Requirements:*

- Knowledge of the telephone, its menu options and the required PIN, if necessary
- Headset operation enabled

Press the **function Key** configured for automatic call acceptance to switch automatic call acceptance on or off.

Or, proceed as described in the following.

1. Press the **menu key** and open the menu **functions > auto call accept**.

The ● icon indicates the current setting.

2. Select the desired option:

**switch on:** Enables automatic call acceptance.

**switch off:** Disables automatic call acceptance.

---

**Note:** Switching on automatic call acceptance automatically switches off the readiness of answering machine in a telephone. On the other hand, switching on the readiness of answering machine automatically switches off automatic call acceptance.

---

## Configuring and Operating Function Key for Automatic Call Acceptance

Press the key to switch the automatic call acceptance function on or off or to switch it over.

In addition, when functions are defined on the first key level, the status of the function is indicated by the corresponding LED.

### LED signalling next to the key:

Green	Automatic call acceptance is enabled.
Off	Automatic call acceptance is disabled.

The configuration can be carried out as follows:

- Via COMfortel Set
- Via the telephone menu

### Configuring Function Key for Automatic Call Acceptance via COMfortel Set

*Requirements:*

– An open configuration and the required PIN, if necessary

1. Open the page **Function keys > Assign function keys**.
2. Only available in installed extension modules: In the telephone displayed at the top left, click the key group in which you would like to define keys.
3. Click one of the following tabs:
  - Level 1:** Keys are defined on the first key level.
  - Level 2:** Keys are defined on the second key level.
4. Right-click the function key you want to assign.  
A function selection dialogue opens.
5. Select the **Automatic call acceptance** function.  
The current settings for defining the key are displayed.

6. In the **Kind of switching** list field, select one of the following options:
  - switch off:** Press the key to disable automatic call acceptance.
  - switch on:** Press the key to enable automatic call acceptance. At the same time, the readiness of answering machine in a telephone is disabled.
  - switch over:** Press the key to switch automatic call acceptance over.
7. In the **Key name** entry field, enter a name for the key. The following entries are possible:
  - Up to 16 digits
  - Digits and characters

Clicking  automatically enters the default name in the entry field.

---

**Note:** The key name is used for printing the label.

---

*Further steps:*

- *Save your configuration before closing.*

*Requirements for operating the function:*

- *Headset operation enabled*

### **Configuring Function Key for Automatic Call Acceptance via Telephone Menu**

*Requirements:*

- *Knowledge of the telephone, its menu options and the required PIN, if necessary*

1. Press the **menu key** and open the **define keys** menu.
2. Press the **function key** that you would like to define.
3. Select the desired option:
  - first level:** Keys are defined on the first key level.
  - second level:** Keys are defined on the second key level.The list of available functions is displayed.
4. Select the **auto call accept** function.

The current settings for defining the key are shown on the display.

5. Select the kind of switching. Press the  **softkey** to switch over between the different kinds of switching.

**switch off:** Press the key to disable automatic call acceptance.

**switch on:** Press the key to enable automatic call acceptance. At the same time, the readiness of answering machine in a telephone is disabled.

**switch over:** Press the key to switch automatic call acceptance over.

6. Press the  **softkey** to accept the setting.

*Requirements for operating the function:*

- *Headset operation enabled*

---

## Attention Tone for Switching Automatic Call Acceptance On/Off

If the attention tone for automatic call acceptance is switched on, the automatic call acceptance of a currently incoming call is signalled by an attention tone. If the attention tone bothers you, you can switch it off. The volume of the attention tone is dependent on the configured ringer volume.

Switching this on/off can be done as follows:

- Via COMfortel Set
- Via the telephone menu

### Switching Attention Tone for Automatic Call Acceptance On/Off via COMfortel Set

*Requirements:*

- *An open configuration and the required PIN, if necessary*

1. Open the page **Settings/functions > Headset**.
2. Select or clear the **Attention tone for automatic call acceptance** check box.
  - Enables the attention tone for automatic call acceptance.
  - Disables the attention tone for automatic call acceptance.

*Further steps:*

- *Save your configuration before closing.*

## **Switching Attention Tone for Automatic Call Acceptance On/Off via Telephone Menu**

### *Requirements:*

– Knowledge of the telephone, its menu options and the required PIN, if necessary

1. Press the **menu key** and open the menu **settings > headset > auto call accept > indicator tone**.
2. Select or clear the **indicator tone** check box.
  - Enables the attention tone for automatic call acceptance.
  - Disables the attention tone for automatic call acceptance.
3. Press the **✓ softkey** to accept the setting.

---

## **Configuring Call Acceptance Time for Automatic Call Acceptance**

The call acceptance time for automatic call acceptance indicates after how many seconds an incoming call is automatically accepted.

The configuration can be made as follows:

- Via COMfortel Set
- Via the telephone menu

## **Configuring Call Acceptance Time for Automatic Call Acceptance via COMfortel Set**

### *Requirements:*

– An open configuration and the required PIN, if necessary

1. Open the page **Settings/functions > Headset**.
2. Enter a value in the **Call acceptance time (0-30 secs) for automatic call acceptance** entry field. The following entries are possible:
  - 0 to 30:** After 0 to 30 minutes, an incoming call is automatically accepted, depending on the entry.

### *Further steps:*

– Save your configuration before closing.

## **Configuring Call Acceptance Time for Automatic Call Acceptance via Telephone Menu**

### *Requirements:*

– *Knowledge of the telephone, its menu options and the required PIN, if necessary*

1. Press the **menu key** and open the menu **settings > headset > auto call accept > call accept time**.
2. Enter a value. The following entries are possible:
  - 0 to 30:** After 0 to 30 minutes, an incoming call is automatically accepted, depending on the entry.
3. Press the **✓ softkey** to save the entry.

## Boss/Secretary Function

The boss/secretary function protects the boss telephone from direct calls by rerouting them to the secretary. The most important difference from call forwarding is that the boss telephone can still be called from the secretary telephone and the secretary can still transfer important calls to the boss telephone.

---

### Procedure when Calling the Boss Telephone

If the boss/secretary function has been switched on, calls to the boss telephone are made as follows:

- All internal and external calls (also call through) as well as door calls and callbacks initiated by the caller are rerouted to the secretary's telephone in question. The following types of calls are not rerouted to the secretary's telephone even when the boss/secretary function has been switched on:
  - Alarm calls
  - Scheduled calls
  - InterCom calls (if permitted)
  - Wake-up calls
  - Callbacks initiated from the boss telephone
  - Callbacks after a system software update
  - Repeated calls from the boss telephone after an exchange transfer

---

**Important:** When the boss/secretary function is switched on, incoming calls are also rerouted to the secretary when the functions do-not-disturb, call restrictor incoming or call forwarding for subscribers are enabled on the boss telephone. On the other hand, a call from the secretary to the boss telephone is rerouted if call forwarding is enabled or signals busy if do-not-disturb is enabled.

---

- The rerouted calls are shown on the display of the boss telephone and can be accepted by pressing the secretary key (pick-up).
- If a rerouted call is picked up on the secretary's telephone, the call can be treated normally. If multiple boss keys have been programmed, the red blinking LED lights up next to the boss key indicating the boss telephone it is assigned to.



---

**Note:** On the secretary's telephone, in addition to the boss key, it is also a good idea to configure a speed dialling key for the phone number of the boss telephone in order to keep track of whether it is busy or not.

---

- It is possible to initiate a query call to the boss telephone or to forward a call to the boss telephone by pressing a boss key on the secretary's telephone.

---

**Note:** In order to recognise a call coming from the secretary's telephone, the secretary's telephone number can be entered into the telephone book on the boss telephone and assigned a specific ringer rhythm.

---

---

## Switching Boss/Secretary Function on Boss Telephone On/Off

Switching this on/off can be done as follows:

- Via the telephone menu

### *Requirements:*

- *Knowledge of the telephone, its menu options and the required PIN, if necessary*
- *A secretary key configured on the boss telephone*
- *A suitably configured boss key on the secretary telephone*

- Press the **function key** configured as the secretary key.

---

## Configuring and Operating Secretary Key on Boss Telephone

---

### **Note:**

It is not possible to configure boss keys and secretary keys to exist simultaneously on the same telephone; this means that a telephone cannot be both a boss telephone and a secretary telephone at the same time.

When operated on the PBXs COMpact 2204 USB, COMpact 2206 USB, COMpact 4406 DSL, COMpact 4410 USB and COMmander Basic: A maximum of five secretary keys can be configured on a boss telephone.

When operated on the PBXs COMpact 5010 VoIP, COMpact 5020 VoIP, COMmander Basic.2 and COMmander Business: A maximum of one secretary key can be configured on a boss telephone. Multiple secretary telephones must be linked in a group.

---

Press the key while in the telephone's idle state to switch the boss/secretary function on or off.

During an incoming call, rerouted calls are shown on the display of the boss telephone. Press the secretary key to pick up this call.

In addition, the corresponding LED indicates the status of the function.

#### **LED signalling next to the secretary key:**

Green	The boss/secretary function is enabled. The secretary telephone is currently not being used for a call. Press the key to switch the boss/secretary function on and off.
Red (blinking)	The boss/secretary function is enabled. A call has just been forwarded to the associated secretary. Press the key to initiate a pick-up.
Red	The boss/secretary function is enabled. The associated secretary is not available. In this case, a caller hears a busy signal unless call waiting is enabled on the secretary telephone. If the boss/secretary function is still enabled for additional telephones, the call is rerouted to one of them.
Off	The boss/secretary function is disabled. Press the key to enable the boss/secretary function.

The configuration can be carried out as follows:

- Via COMfortel Set
- Via the telephone menu

#### **Configuring Secretary Key on Boss Telephone via COMfortel Set**

*Requirements:*

– An open configuration and the required PIN, if necessary

1. Open the page **Function keys > Assign function keys**.

2. Only available in installed extension modules: In the telephone displayed at the top left, click the key group in which you would like to define keys.
3. Click the **Level 1** tab.

---

**Important:** Configuring this function is only possible on the first level.

---

4. Right-click the function key you want to assign.  
A function selection dialogue opens.
5. Select the **Secretary key** function.  
The current settings for defining the key are displayed.
6. In the **Telephone no** entry field, enter the telephone number for the secretary telephone.
7. In the **Key name** entry field, enter a name for the key. The following entries are possible:
  - Up to 16 digits
  - Digits and characters

Clicking  automatically enters the default name in the entry field.

---

**Note:** The key name is used for printing the label and for display.

---

*Further steps:*

- *Save your configuration before closing.*

*Requirements for operating the function:*

- *A suitably configured boss key on the secretary telephone*

### **Configuring Secretary Key for Boss Telephone via Telephone Menu**

*Requirements:*

- *Knowledge of the telephone, its menu options and the required PIN, if necessary*

1. Press the **menu key** and open the **define keys** menu.



2. Press the **function key** that you would like to define.
3. Select **first level**.

---

**Important:** Configuring this function is only possible on the first level.

---

The list of available functions is displayed.

4. Select the **secretary key** function.  
The current settings for defining the key are shown on the display.
5. Press the  **softkey**.
6. Select an internal phone number on the PBX to be the secretary telephone.
7. Press the  **softkey**.
8. Enter a name for the phone number. The following entries are possible:
  - Up to 16 digits
  - Digits and characters
9. Press the  **softkey** to accept the setting.

*Requirements for operating the function:*

- *A suitably configured boss key on the secretary telephone*

---

## Configuring and Operating Boss Key on Secretary Telephone

---

### **Note:**

It is not possible to configure boss keys and secretary keys to exist simultaneously on the same telephone; this means that a telephone cannot be both a boss telephone and a secretary telephone at the same time.

A maximum of five boss keys can be configured on one telephone.

---

Press the key to initiate a call or a callback to the corresponding boss telephone.

In addition, the corresponding LED indicates the status of the function.

**LED signalling next to the boss key:**

- |                |  |
|----------------|--|
| Green          | The boss/secretary function is enabled.  |
| Red (blinking) | The boss/secretary function is enabled. The call received has been forwarded to the corresponding boss telephone. Press the key to initiate a call back on the boss telephone. |
| Off            | The boss/secretary function is disabled.   |

The configuration can be carried out as follows:

- Via COMfortel Set
- Via the telephone menu

**Configuring Boss Key on Secretary Telephone via COMfortel Set**

*Requirements:*

– An open configuration and the required PIN, if necessary

1. Open the page **Function keys > Assign function keys**.
2. Only available in installed extension modules: In the telephone displayed at the top left, click the key group in which you would like to define keys.
3. Click the **Level 1** tab.

---

**Important:** Configuring this function is only possible on the first level.

---

4. Right-click the function key you want to assign.  
A function selection dialogue opens.
5. Select the **Boss key** function.  
The current settings for defining the key are displayed.
6. In the **Telephone no** entry field, enter the internal telephone number for the boss telephone.

7. In the **Key name** entry field, enter a name for the key. The following entries are possible:

- Up to 16 digits
- Digits and characters

Clicking  automatically enters the default name in the entry field.

---

**Note:** The key name is used for printing the label and for display.

---

*Further steps:*

- *Save your configuration before closing.*

*Requirements for operating the function:*

- *A suitably configured secretary key on the boss telephone*

### **Configuring Boss Key on Secretary Telephone via Telephone Menu**

*Requirements:*

- *Knowledge of the telephone, its menu options and the required PIN, if necessary*



1. Press the **menu key** and open the **define keys** menu.
2. Press the **function key** that you would like to define.
3. Select **first level**.

---

**Important:** Configuring this function is only possible on the first level.

---

The list of available functions is displayed.

4. Select the **boss key** function.  
The current settings for defining the key are shown on the display.
5. Press the  **softkey**.
6. Select an internal phone number on the PBX to be the boss telephone.
7. Press the  **softkey**.

8. Enter a name for the phone number. The following entries are possible:
  - Up to 16 digits
  - Digits and characters
9. Press the **✓ softkey** to accept the setting.

*Requirements for operating the function:*

- A suitably configured secretary key on the boss telephone

---

## Switching Boss/Secretary Function for All Secretary Keys Off

---

**Important:** Only available for operation on the PBXs COMpact 2204 USB, COMpact 2206 USB, COMpact 4406 DSL, COMpact 4410 USB and COMmander Basic.

---

Switching this off can be done as follows:

- Via the telephone menu

*Requirements:*

- Knowledge of the telephone, its menu options and the required PIN, if necessary
- A secretary key configured on the boss telephone
- A suitably configured boss key on the secretary telephone

To switch off the boss/secretary function for all of the secretary keys at the same time, press the **function key** that has been configured for switching off the boss/secretary function.

Or, proceed as described in the following.

- Press the **menu key** and open the menu **Functions > boss->secr. off.**

---

## Configuring and Operating Function Key for Switching Boss/Secretary Function Off

---

**Important:** Only available for operation on the PBXs COMpact 2204 USB, COMpact 2206 USB, COMpact 4406 DSL, COMpact 4410 USB and COMmander Basic.

---

Pressing the key switches the boss/secretary function off on all the secretary keys configured on the telephone.

### LED signalling next to the key:

None

The configuration can be carried out as follows:

- Via COMfortel Set
- Via the telephone menu

### Configuring Function Key for Switching Boss/Secretary Function Off via COMfortel Set

*Requirements:*

– An open configuration and the required PIN, if necessary

1. Open the page **Function keys > Assign function keys**.
2. Only available in installed extension modules: In the telephone displayed at the top left, click the key group in which you would like to define keys.
3. Click one of the following tabs:
  - Level 1:** Keys are defined on the first key level.
  - Level 2:** Keys are defined on the second key level.
4. Right-click the function key you want to assign.  
A function selection dialogue opens.
5. Select the **Boss/secretary function** function.  
The current settings for defining the key are displayed.



6. In the **Key name** entry field, enter a name for the key. The following entries are possible:

Up to 16 digits

Digits and characters

Clicking  automatically enters the default name in the entry field.

---

**Note:** The key name is used for printing the label.

---

*Further steps:*

- *Save your configuration before closing.*

*Requirements for operating the function:*

- *A secretary key configured on the boss telephone*
- *A suitably configured boss key on the secretary telephone*

## Configuring Function Key for Switching Boss/Secretary Function On/Off via Telephone Menu

*Requirements:*

- *Knowledge of the telephone, its menu options and the required PIN, if necessary*

1. Press the **menu key** and open the **define keys** menu.

2. Press the **function key** that you would like to define.

3. Select the desired option:

**first level:** Keys are defined on the first key level.

**second level:** Keys are defined on the second key level.

The list of available functions is displayed.

4. Select the **boss->secr. off** function.

The current settings for defining the key are shown on the display.

5. Press the **✓ softkey** to accept the setting.

*Requirements for operating the function:*

- *A secretary key configured on the boss telephone*
- *A suitably configured boss key on the secretary telephone*

## Call Deblocker (Incoming) – VIP Numbers

If you would still like to allow specific people to call you despite enabling the do-not-disturb function, the external telephone numbers (VIP numbers) of these people can be assigned a call deblocker for incoming calls in the PBX. The call deblocker which applies to all subscribers can be enabled on your own telephone as needed. If the call deblocker is enabled, the do-not-disturb function does not apply to callers who use one of the VIP numbers.

---

### Switching Call Deblocker (Incoming) On/Off

Switching this on/off can be done as follows:

- Via the telephone menu

#### *Requirements:*

- *Knowledge of the telephone, its menu options and the required PIN, if necessary*
- *A call deblocker configured on the PBX and assigned to the subscriber*
- *Authorisation in the PBX for **Controlling of the PBX via telephone***
- *Kind of do-not-disturb configured to **all (PBX)***

In order to activate or deactivate the call deblocker, press the **function key** configured for the call deblocker (incoming).

Or, proceed as described in the following.

1. Press the **menu key** and open the menu **functions > Call Deblocker**.

The ● icon indicates the current setting.

2. Select the desired option:

**switch on:** Enables the call deblocker.

**switch off:** Disables the call deblocker.

## Configuring and Operating Function Key for Call Deblocker (Incoming)

Press the key to switch the subscriber's call deblocker on or off or to switch it over.

In addition, when functions are defined on the first key level, the status of the function is indicated by the corresponding LED.

### LED signalling next to the key:

Green	The call deblocker is enabled.
Off	The call deblocker is disabled.

The configuration can be carried out as follows:

- Via COMfortel Set
- Via the telephone menu

### Configuring Function Key for the Call Deblocker (Incoming) via COMfortel Set

*Requirements:*

– An open configuration and the required PIN, if necessary

1. Open the page **Function keys > Assign function keys**.
2. Only available in installed extension modules: In the telephone displayed at the top left, click the key group in which you would like to define keys.
3. Click one of the following tabs:
  - Level 1:** Keys are defined on the first key level.
  - Level 2:** Keys are defined on the second key level.
4. Right-click the function key you want to assign.  
A function selection dialogue opens.
5. Select the **Call deblocker - incoming (VIP no.)** function.  
The current settings for defining the key are displayed.
6. In the **Kind of switching** list field, select one of the following options:
  - switch off:** Pressing the key disables call deblocker.

**switch on:** Pressing the key enables call deblocker.

**switch over:** Pressing the key switches call deblocker on and off.

7. In the **Key name** entry field, enter a name for the key. The following entries are possible:

Up to 16 digits

Digits and characters

Clicking  automatically enters the default name in the entry field.

---

**Note:** The key name is used for printing the label.

---

*Further steps:*

- *Save your configuration before closing.*

*Requirements for operating the function:*

- *Unrestricted numbers configured on the PBX and assigned to the subscriber*
- *Authorisation in the PBX for **Controlling of the PBX via telephone***
- *Kind of do-not-disturb configured to **All (PBX)***

### **Configuring Function Key for Call Deblocker (Incoming) via Telephone Menu**

*Requirements:*

- *Knowledge of the telephone, its menu options and the required PIN, if necessary*

1. Press the **menu key** and open the **define keys** menu.
2. Press the **function key** that you would like to define.
3. Select the desired option:

**first level:** Keys are defined on the first key level.

**second level:** Keys are defined on the second key level.

The list of available functions is displayed.

4. Select the **Call Deblocker** function.

The current settings for defining the key are shown on the display.

## Configuring and Operating Functions

Call Deblocker (Incoming) – VIP Numbers

Configuring and Operating Function Key for Call Deblocker (Incoming)

5. Select the kind of switching. Pressing the  **softkey** allows you to switch over between the different kinds of switching.

**switch off:** Pressing the key disables the call deblocker.

**switch on:** Pressing the key enables the call deblocker.

**switch over:** Pressing the key switches the call deblocker on and off.

6. Press the  **softkey** to accept the setting.

*Requirements for operating the function:*

- A call deblocker configured on the PBX and assigned to the subscriber
- Authorisation in the PBX for **Controlling of the PBX via telephone**
- Kind of do-not-disturb configured to **all (PBX)**

# Call Forwarding

Call forwarding allows calls to be forwarded. When this is done, a difference is made between calls to a specific telephone (call forwarding for subscribers), to groups (call forwarding for groups) and to connections (call forwarding for external telephone numbers).

---

## Call Forwarding Variations

Auerswald PBXs support three different kinds of call forwarding:

### Call Forwarding for Subscribers

---

**Important:** Not available for operation on the PBX COMpact 3000.

---

When call forwarding (CF) for subscribers is used, internal and external calls to a single telephone can be rerouted to other internal telephones or external connections. In this way, the subscriber in question or his replacement can take these calls on another telephone.

Call forwarding for subscribers makes sure that the subscriber in question or his replacement is always available at his own phone number, even if the subscriber cannot take a call on his own telephone.

---

**Important:** Call forwarding for subscribers does not function for incoming group calls on your telephone. If you would like to prevent your telephone from ringing unanswered when calls to the group in which you belong come through, you need to log yourself out of the group or configure call forwarding for groups.

**Note:** If you would like to configure call forwarding for subscribers on the destination telephone, use the follow me function.

---

### Call Forwarding for Groups

---

**Important:** Not available for operation on the PBX COMpact 3000.

---

When call forwarding for groups is used, internal and external calls to a group can be rerouted to other internal telephones or external connections. In this way, a person that is not a member of this group and therefore cannot log in, can receive these calls.

Call forwarding for groups makes sure that someone is always available on the group telephone number, even if the calls cannot be taken by a member of the group.

To configure call forwarding for groups, refer to the user manual for the PBX.

### **Call Forwarding for External Numbers**

When call forwarding for external numbers is used, calls made to an external phone number (dialled by an external caller) are rerouted to other external connections. In this way, these calls can be taken on another telephone, for example, on a mobile phone if no one can take the call internally.

Call forwarding for external numbers can be configured for the current configuration or for the permanent configuration.

---

**Note:** If you would like to also forward internal calls, use call forwarding for subscribers or for groups instead of call forwarding for external numbers. This also allows forwarding to internal telephones.

---

---

## **Kinds of Call Forwarding**

As there can be many different reasons for not accepting a call, for example, the subscriber in question is not present or is on another line, three kinds of call forwarding are provided:

### **CF unconditional**

The telephone being called does not ring. The call is forwarded immediately.

### **CF on busy**

The call is forwarded immediately but only if the telephone being called is busy.

### **CF on no reply**

The telephone being called rings for a certain amount of time. If the call is not accepted, it is forwarded.

---

**Note:**

A different destination can be configured for each of the three kinds of call forwarding.

If "CF on busy" and "CF on no reply" are enabled at the same time, both kinds apply. Depending on which case occurs – the telephone is busy or nobody answers it – the call is forwarded to their respective telephone numbers.

If "CF unconditional" is enabled in addition to the "CF on busy" and/or "CF on no reply," all of the calls are forwarded immediately. In this case, the other kinds of call forwarding are overridden, but remain enabled. As soon as "CF unconditional" is disabled, the other kinds that are still enabled are again applicable.

---

---

## Switching Call Forwarding for Subscribers On/Off

Switching this on/off can be done as follows:

- Via the telephone menu

### *Requirements:*

- Knowledge of the telephone, its menu options and the required PIN, if necessary
- Authorisation in the PBX for **Controlling of the PBX via telephone**
- For external destination numbers: Authorization assigned in the PBX for **Configuring CF (sub) to ext. number**

To enable or disable call forwarding for subscribers, press the **function key** configured for call forwarding (subscribers).

Or, proceed as described in the following.

1. Press the **menu key** and open the menu **functions > Call fwd.:scr.**
2. Select the desired option:
  - deactivate all:** Disables all currently enabled call forwarding for subscribers. (No other action is required.)
  - unconditional:** Switches call forwarding unconditional for subscribers on or off.
  - on busy:** Switches call forwarding on busy for subscribers on or off.
  - on no reply:** Switches call forwarding on no reply for subscribers on or off.

The ● icon indicates the current setting.



3. Select the desired option:

**switch on:** Enables call forwarding for subscribers.

**switch off:** Disables call forwarding for subscribers. (No other action is required.)

---

**Note:** If you press the **Telephone book key** before entering the destination number, you can select the desired phone number from the telephone book.

---

4. Enter the destination number. The following entries are possible:

Up to 24 digits

Digits and the characters \* and #

---

**Important:** Enter telephone numbers exactly as when dialling, for example, external telephone numbers always with a leading exchange line access number. (exception: direct exchange access). The default exchange line access number on the PBX is "0" in the factory settings; however, this can be changed for several PBXs (see the PBX manual).

---

5. Press the  **softkey** to save the entry.

---

## Configuring and Operating Function Key for Call Forwarding for Subscribers

Press the key to enable, disable and switch call forwarding for subscribers over.

Exception: A key that is defined to disable call forwarding for subscribers only disables the currently enabled call forwarding for subscribers.

In addition, when functions are defined on the first key level, the status of the function is indicated by the corresponding LED.

### LED signalling next to the key (not applicable if defined with "deactivate all"):

Red            Call forwarding for subscribers is enabled for the configured destination.

Yellow        Call forwarding for subscribers is enabled for another destination.

Off            Call forwarding for subscribers is disabled.

The configuration can be carried out as follows:

- Via COMfortel Set
- Via the telephone menu

### **Configuring Function Key for Call Forwarding Unconditional for Subscribers via COMfortel Set**

*Requirements:*

– An open configuration and the required PIN, if necessary

1. Open the page **Function keys > Assign function keys**.
2. Only available in installed extension modules: In the telephone displayed at the top left, click the key group in which you would like to define keys.
3. Click one of the following tabs:
  - Level 1:** Keys are defined on the first key level.
  - Level 2:** Keys are defined on the second key level.
4. Right-click the function key you want to assign.  
A function selection dialogue opens.
5. Select the **Subscriber CF unconditional** function.  
The current settings for defining the key are displayed.
6. In the **Kind of switching** list field, select one of the following options:
  - switch off:** Pressing the key disables call forwarding unconditional for subscribers.
  - switch on:** Pressing the key enables call forwarding unconditional for subscribers.
  - switch over:** Pressing the key switches call forwarding unconditional for subscribers over.
7. In the **Telephone no** entry field, enter the destination number. The following entries are possible:
  - Up to 24 digits
  - Digits and the characters \* and #

Click  to accept a telephone number from the telephone book in the **Telephone no** entry field.

8. In the **Type of telephone number** list field, select one of the following options:

**Internal no.:** Defines the destination number entered as an internal telephone number.

**External no.:** Defines the destination number entered as an external telephone number.

9. In the **Key name** entry field, enter a name for the key. The following entries are possible:

Up to 16 digits

Digits and characters

Clicking  automatically enters the default name in the entry field.

---

**Note:** The key name is used for printing the label.

---

*Further steps:*

- *Save your configuration before closing.*

*Requirements for operating the function:*

- *Authorisation in the PBX for **Controlling of the PBX via telephone***
- *For external destination numbers: Authorization assigned in the PBX for **Configuring CF (sub) to ext. number***

## **Configuring Function Key for Call Forwarding on Busy for Subscribers via COMfortel Set**

*Requirements:*

- *An open configuration and the required PIN, if necessary*

1. Open the page **Function keys > Assign function keys**.
2. Only available in installed extension modules: In the telephone displayed at the top left, click the key group in which you would like to define keys.

3. Click one of the following tabs:

**Level 1:** Keys are defined on the first key level.

**Level 2:** Keys are defined on the second key level.

4. Right-click the function key you want to assign.

A function selection dialogue opens.

5. Select the **Subscriber CF on busy** function.

The current settings for defining the key are displayed.

6. In the **Kind of switching** list field, select one of the following options:

**switch off:** Pressing the key disables call forwarding on busy for subscribers.

**switch on:** Pressing the key enables call forwarding on busy for subscribers.

**switch over:** Pressing the key switches call forwarding on busy for subscribers off.

7. In the **Telephone no** entry field, enter the destination number. The following entries are possible:

Up to 24 digits

Digits and the characters \* and #

Click  to accept a telephone number from the telephone book in the **Telephone no** entry field.

8. In the **Type of telephone number** list field, select one of the following options:

**Internal no.:** Defines the destination number entered as an internal telephone number.

**External no.:** Defines the destination number entered as an external telephone number.

9. In the **Key name** entry field, enter a name for the key. The following entries are possible:

Up to 16 digits

Digits and characters

Clicking  automatically enters the default name in the entry field.

---

**Note:** The key name is used for printing the label.

---

*Further steps:*

- *Save your configuration before closing.*

*Requirements for operating the function:*

- *Authorisation in the PBX for **Controlling of the PBX via telephone***
- *For external destination numbers: Authorization assigned in the PBX for **Configuring CF (sub) to ext. number***

**Configuring Function Key for Call Forwarding on No Reply for Subscribers via COMfortel Set**

*Requirements:*

- *An open configuration and the required PIN, if necessary*

1. Open the page **Function keys > Assign function keys**.
2. Only available in installed extension modules: In the telephone displayed at the top left, click the key group in which you would like to define keys.
3. Click one of the following tabs:
  - Level 1:** Keys are defined on the first key level.
  - Level 2:** Keys are defined on the second key level.
4. Right-click the function key you want to assign.  
A function selection dialogue opens.
5. Select the **Subscriber CF on no reply** function.  
The current settings for defining the key are displayed.
6. In the **Kind of switching** list field, select one of the following options:
  - switch off:** Pressing the key disables call forwarding on no reply for subscribers.
  - switch on:** Pressing the key enables call forwarding on no reply for subscribers.
  - switch over:** Pressing the key switches call forwarding on no reply for subscribers.

7. In the **Telephone no** entry field, enter the destination number. The following entries are possible:

Up to 24 digits

Digits and the characters \* and #

Click  to accept a telephone number from the telephone book in the **Telephone no** entry field.

8. In the **Type of telephone number** list field, select one of the following options:

**Internal no.:** Defines the destination number entered as an internal telephone number.

**External no.:** Defines the destination number entered as an external telephone number.

9. In the **Key name** entry field, enter a name for the key. The following entries are possible:

Up to 16 digits

Digits and characters

Clicking  automatically enters the default name in the entry field.

---

**Note:** The key name is used for printing the label.

---

*Further steps:*

- *Save your configuration before closing.*

*Requirements for operating the function:*

- *Authorisation in the PBX for **Controlling of the PBX via telephone***
- *For external destination numbers: Authorization assigned in the PBX for **Configuring CF (sub) to ext. number***

## **Configuring Function Key for Switching Call Forwarding for Subscribers Off via COMfortel Set**

### *Requirements:*

- *An open configuration and the required PIN, if necessary*

1. Open the page **Function keys > Assign function keys**.
2. Only available in installed extension modules: In the telephone displayed at the top left, click the key group in which you would like to define keys.
3. Click one of the following tabs:
  - Level 1:** Keys are defined on the first key level.
  - Level 2:** Keys are defined on the second key level.
4. Right-click the function key you want to assign.  
A function selection dialogue opens.
5. Select the **Switch off all subscriber CF** function.  
The current settings for defining the key are displayed.
6. In the **Key name** entry field, enter a name for the key. The following entries are possible:
  - Up to 16 digits
  - Digits and characters

Clicking  automatically enters the default name in the entry field.

---

**Note:** The key name is used for printing the label.

---

### *Further steps:*

- *Save your configuration before closing.*



### *Requirements for operating the function:*

- *Authorisation in the PBX for **Controlling of the PBX via telephone***
- *For external destination numbers: Authorization assigned in the PBX for **Configuring CF (sub) to ext. number***

## **Configuring Function Key for Call Forwarding for Subscribers via Telephone Menu**

### *Requirements:*

– Knowledge of the telephone, its menu options and the required PIN, if necessary

1. Press the **menu key** and open the **define keys** menu.
2. Press the **function key** that you would like to define.
3. Select the desired option:
  - first level:** Keys are defined on the first key level.
  - second level:** Keys are defined on the second key level.The list of available functions is displayed.
4. Select the **Call fwd.:scr** function.
5. Select the desired option:
  - deactivate all:** Defines a key with the Switch off all function. (No other action is required.)
  - unconditional:** Defines a key with the call forwarding unconditional for subscribers function.
  - on busy:** Defines a key with the call forwarding on busy for subscribers function.
  - on no reply:** Defines a key with the call forwarding on no reply for subscribers function.The current settings for defining the key are shown on the display.
6. Select the kind of switching. Pressing the  **softkey** allows you to switch over between the different kinds of switching.
  - switch off:** Pressing the key disables call forwarding for subscribers. (No other action is required.)
  - switch on:** Pressing the key enables call forwarding for subscribers.
  - switch over:** Pressing the key switches call forwarding for subscribers over.
7. Press the  **softkey**.

---

**Note:** If you press the **Telephone book key** before entering the destination number, you can select the desired phone number from the telephone book.

---



8. Enter the destination number. The following entries are possible:

Up to 24 digits

Digits and the characters \* and #

---

**Important:** Enter telephone numbers exactly as when dialling, for example, external telephone numbers always with a leading exchange line access number. (exception: direct exchange access). The default exchange line access number on the PBX is "0" in the factory settings; however, this can be changed for several PBXs (see the PBX manual).

---

9. Press the  **softkey**.

10. Enter a name. The following entries are possible:

Up to 16 digits

Digits and characters

11. Press the  **softkey** to accept the setting.

*Requirements for operating the function:*

- *Authorisation in the PBX for **Controlling of the PBX via telephone***
- *For external destination numbers: Authorization assigned in the PBX for **Configuring CF (sub) to ext. number***

---

## Switching Call Forwarding for External Numbers On/Off

---

**Important:** Only available for operation on the PBXs COMpact 3000, COMpact 5010 VoIP, COMpact 5020 VoIP, COMmander Basic.2 and COMmander Business. On the other PBXs this function can be set via programming sequence (see manual of the PBX).

---

Switching this on/off can be done as follows:

- Via the telephone menu

*Requirements:*

- Knowledge of the telephone, its menu options and the required PIN, if necessary
- Authorization assigned in the PBX for **Configuring CF (sub) to ext. number**

To enable or disable call forwarding for external numbers, press the **function key** configured for call forwarding (external numbers).

Or, proceed as described in the following.

1. Press the **menu key** and open the menu **functions > CF ext.no..**
2. Select the desired option:
  - time control:** Switches permanent configuration off and the current condition on.)
  - deactivate all:** Disables all currently enabled call forwarding for subscribers. (No other action is required.)
  - unconditional:** Switches call forwarding unconditional for external numbers on or off.
  - on busy:** Switches call forwarding on busy for external numbers on or off.
  - on no reply:** Switches call forwarding on no reply for external numbers on or off.
3. Enter the external phone number to be forwarded on the PBX (without an exchange line access number). The following entries are possible:
  - Up to 24 digits
  - Digits and the characters \* and #
4. Press the **✓ softkey**.  
The **●** icon indicates the current setting.
5. Select the desired option:
  - switch on:** Enables call forwarding for external numbers.  
For time control: Switches the current configuration on and the permanent configuration off. (No other action is required.)
  - switch off:** Disables call forwarding for external numbers. (No other action is required.)  
For time control: Switches the current configuration off and the permanent configuration on. (No other action is required.)

---

**Note:** If you press the **telephone book key** before entering the destination number, you can select the desired phone number from the telephone book.

---

6. Enter the destination number (with exchange line access number). The following entries are possible:
  - Up to 24 digits
  - Digits and the characters \* and #
7. Press the **✓ softkey** to save the entry.

---

## Configuring and Operating Function Key for Call Forwarding for External Numbers

---

**Important:** Only available for operation on the PBXs COMpact 3000, COMpact 5010 VoIP, COMpact 5020 VoIP, COMmander Basic.2 and COMmander Business. On the other PBX systems this function can be set via programming sequence (see manual of the PBX).

---

Pressing the key enables, disables and switches call forwarding for external numbers over.

Exception: A key defined to disable all instances of call forwarding for external numbers only disables call forwarding for external numbers for which a key has been configured.

In addition, when functions are defined on the first key level, the status of the function is indicated by the corresponding LED.

### LED signalling next to the key (not applicable if defined with "deactivate all"):

Red	Call forwarding for external numbers is enabled in the central office/PBX for the configured destination and selected configuration.
Yellow	Call forwarding on busy or on no reply for external numbers has been configured, but it is overridden by an additional call forwarding unconditional for external numbers.
Yellow	Call forwarding for external numbers is enabled in the central office/PBX for another destination or configuration.
Off	Call forwarding for external numbers is disabled in the central office/PBX.

---

**Important:** When operating the function via the key, the success/failure of the operation is indicated by a change in colour on the LED. During the configuration in the central office (this takes perhaps from a few seconds up to a minute), the LED blinks yellow.

---

The configuration can be carried out as follows:

- Via COMfortel Set
- Via the telephone menu

### **Configuring Function Key for Call Forwarding Unconditional for External Numbers via COMfortel Set**

*Requirements:*

– An open configuration and the required PIN, if necessary

1. Open the page **Function keys > Assign function keys**.
2. Only available in installed extension modules: In the telephone displayed at the top left, click the key group in which you would like to define keys.
3. Click one of the following tabs:
  - Level 1:** Keys are defined on the first key level.
  - Level 2:** Keys are defined on the second key level.
4. Right-click the function key you want to assign.  
A function selection dialogue opens.
5. Select the **CF unconditional (MSN/DDI)** function.  
The current settings for defining the key are displayed.
6. In the **Kind of switching** list field, select one of the following options:
  - switch off:** Pressing the key disables call forwarding unconditional for external numbers.
  - switch on:** Pressing the key enables call forwarding unconditional for external numbers.
  - switch over:** Pressing the key switches call forwarding unconditional for external numbers over.

7. In the **Configuration** list field, select one of the following options:

**permanent configuration:** Call forwarding unconditional for external numbers is enabled, disabled or switched over in the permanent configuration.

**current configuration:** Call forwarding unconditional for external numbers is enabled, disabled or switched over only in the current configuration.

---

**Note:** Call forwarding for the current configuration can only be enabled if call forwarding for the permanent configuration is disabled.

---

8. In the **Telephone no** entry field under **Your own exchange line**, enter the external phone number to be forwarded on the PBX (with a prefix). The following entries are possible:

Up to 24 digits

Digits and the characters \* and #

9. In the **Telephone no** entry field under **Destination of Call Forwarding**, enter the destination number (with exchange line access number). The following entries are possible:

Up to 24 digits

Digits and the characters \* and #

Click  to accept a telephone number from the telephone book in the **Telephone no** entry field.

10. In the **Key name** entry field, enter a name for the key. The following entries are possible:

Up to 16 digits

Digits and characters

Clicking  automatically enters the default name in the entry field.

---

**Note:** The key name is used for printing the label.

---

*Further steps:*

- *Save your configuration before closing.*

*Requirements for operating the function:*

- *Authorization assigned in the PBX for **Configuring CF (sub) to ext. number***

## **Configuring Function Key for Call Forwarding on Busy for External Numbers via COMfortel Set**

### *Requirements:*

– An open configuration and the required PIN, if necessary

1. Open the page **Function keys > Assign function keys**.
2. Only available in installed extension modules: In the telephone displayed at the top left, click the key group in which you would like to define keys.
3. Click one of the following tabs:
  - Level 1:** Keys are defined on the first key level.
  - Level 2:** Keys are defined on the second key level.
4. Right-click the function key you want to assign.  
A function selection dialogue opens.
5. Select the **CF on busy (MSN/DDI)** function.  
The current settings for defining the key are displayed.
6. In the **Kind of switching** list field, select one of the following options:
  - switch off:** Pressing the key disables call forwarding on busy for external numbers.
  - switch on:** Pressing the key enables call forwarding on busy for external numbers.
  - switch over:** Pressing the key switches call forwarding on busy for external numbers over.
7. In the **Configuration** list field, select one of the following options:
  - permanent configuration:** Call forwarding on busy for external numbers is enabled, disabled or switched over in the permanent configuration.
  - current configuration:** Call forwarding on busy for external numbers is enabled, disabled or switched over only in the current configuration.

---

**Note:** Call forwarding for the current configuration can only be enabled if call forwarding for the permanent configuration is disabled.

---

8. In the **Telephone no** entry field under **Your own exchange line**, enter the external phone number to be forwarded on the PBX (with a prefix). The following entries are possible:

Up to 24 digits

Digits and the characters \* and #

9. In the **Telephone no** entry field under **Destination of Call Forwarding**, enter the destination number (with exchange line access number). The following entries are possible:

Up to 24 digits

Digits and the characters \* and #

Click  to accept a telephone number from the telephone book in the **Telephone no** entry field.

10. In the **Key name** entry field, enter a name for the key. The following entries are possible:

Up to 16 digits

Digits and characters

Clicking  automatically enters the default name in the entry field.

---

**Note:** The key name is used for printing the label.

---

*Further steps:*

- *Save your configuration before closing.*

*Requirements for operating the function:*

- *Authorization assigned in the PBX for **Configuring CF (sub) to ext. number***

## **Configuring Function Key for Call Forwarding on No Reply for External Numbers via COMfortel Set**

### *Requirements:*

– An open configuration and the required PIN, if necessary

1. Open the page **Function keys > Assign function keys**.
2. Only available in installed extension modules: In the telephone displayed at the top left, click the key group in which you would like to define keys.
3. Click one of the following tabs:
  - Level 1:** Keys are defined on the first key level.
  - Level 2:** Keys are defined on the second key level.
4. Right-click the function key you want to assign.  
A function selection dialogue opens.
5. Select the **CF on no reply (MSN/DDI)** function.  
The current settings for defining the key are displayed.
6. In the **Kind of switching** list field, select one of the following options:
  - switch off:** Pressing the key disables call forwarding on no reply for external numbers.
  - switch on:** Pressing the key enables call forwarding on no reply for external numbers.
  - switch over:** Pressing the key switches call forwarding on no reply for external numbers over.
7. In the **Configuration** list field, select one of the following options:
  - permanent configuration:** Call forwarding on no reply for external numbers is enabled, disabled or switched over in the permanent configuration.
  - current configuration:** Call forwarding on no reply for external numbers is enabled, disabled or switched over only in the current configuration.

---

**Note:** Call forwarding for the current configuration can only be enabled if call forwarding for the permanent configuration is disabled.

---



8. In the **Telephone no** entry field under **Your own exchange line**, enter the external phone number to be forwarded on the PBX (with a prefix). The following entries are possible:

Up to 24 digits

Digits and the characters \* and #

9. In the **Telephone no** entry field under **Destination of Call Forwarding**, enter the destination number (with exchange line access number). The following entries are possible:

Up to 24 digits

Digits and the characters \* and #

Click  to accept a telephone number from the telephone book in the **Telephone no** entry field.

10. In the **Key name** entry field, enter a name for the key. The following entries are possible:

Up to 16 digits

Digits and characters

Clicking  automatically enters the default name in the entry field.

---

**Note:** The key name is used for printing the label.

---

*Further steps:*

- *Save your configuration before closing.*

*Requirements for operating the function:*

- *Authorization assigned in the PBX for **Configuring CF (sub) to ext. number***

## **Configuring Function Key for Switching Call Forwarding for External Numbers Off via COMfortel Set**

### *Requirements:*

- An open configuration and the required PIN, if necessary

1. Open the page **Function keys > Assign function keys**.
2. Only available in installed extension modules: In the telephone displayed at the top left, click the key group in which you would like to define keys.
3. Click one of the following tabs:
  - Level 1:** Keys are defined on the first key level.
  - Level 2:** Keys are defined on the second key level.
4. Right-click the function key you want to assign.  
A function selection dialogue opens.
5. Select the **Switch off all CF (MSN/DDI)** function.  
The current settings for defining the key are displayed.
6. In the **Key name** entry field, enter a name for the key. The following entries are possible:
  - Up to 16 digits
  - Digits and characters

Clicking  automatically enters the default name in the entry field.

---

**Note:** The key name is used for printing the label.

---

### *Further steps:*

- Save your configuration before closing.



### *Requirements for operating the function:*

- Authorization assigned in the PBX for **Configuring CF (sub) to ext. number**

## **Configuring Function Key for Call Forwarding for External Numbers via Telephone Menu**

### *Requirements:*

– Knowledge of the telephone, its menu options and the required PIN, if necessary

1. Press the **menu key** and open the **define keys** menu.
2. Press the **function key** that you would like to define.
3. Select the desired option:
  - first level:** Keys are defined on the first key level.
  - second level:** Keys are defined on the second key level.The list of available functions is displayed.
4. Select the **CF ext.no.** function.
5. Select the desired option:
  - deactivate all:** Defines a key with the Switch off all function. (No other action is required.)
  - unconditional:** Defines a key with the call forwarding unconditional for external numbers function.
  - on busy:** Defines a key with the call forwarding on busy for external numbers function.
  - on no reply:** Defines a key with the call forwarding on no reply for external numbers function.The current settings for defining the key are shown on the display.
6. Select the kind of switching. Pressing the  **softkey** allows you to switch over between the different kinds of switching.
  - switch off:** Pressing the key disables call forwarding for external numbers.
  - switch on:** Pressing the key enables call forwarding for external numbers.
  - switch over:** Pressing the key switches call forwarding for external numbers over.
7. Select the configuration. Pressing the  **softkey** allows you to switch over between the current and the permanent configuration.
  - current config.:** Call forwarding for external numbers is enabled, disabled or switched over only in the current configuration.
  - permanent config:** Call forwarding for external numbers is enabled, disabled or switched over in the permanent configuration.

---

**Note:** Call forwarding for the current configuration can only be enabled if call forwarding for the permanent configuration is disabled.

---

8. Press the  **softkey**.

---

**Note:** If you press the **telephone book key** before entering the destination number, you can select the desired phone number from the telephone book.

---

9. Enter the destination number (with exchange line access number). The following entries are possible:

Up to 24 digits

Digits and the characters \* and #

10. Press the  **softkey**.

11. Enter a name. The following entries are possible:

Up to 16 digits

Digits and characters

12. Press the  **softkey**.

13. Enter the external phone number to be forwarded on the PBX (without an exchange line access number and with a prefix). The following entries are possible:

Up to 24 digits

Digits and the characters \* and #

14. Press the  **softkey** to accept the setting.

*Requirements for operating the function:*

– Authorization assigned in the PBX for **Configuring CF (sub) to ext. number**

## Call Restrictor (Incoming) – Robinson Numbers

If there are certain persons who you absolutely do not want to call you, their external phone numbers (Robinson numbers) can be assigned to a call restrictor for incoming calls in the PBX. The call restrictor which applies to all subscribers can be enabled on your own telephone as needed. If the call restrictor is enabled, a caller, who transmitted one of the Robinson numbers, is rejected.

---

### Switching the Call Restrictor (Incoming) On/Off

Switching this on/off can be done as follows:

- Via the telephone menu

#### *Requirements:*

- Knowledge of the telephone, its menu options and the required PIN, if necessary
- A call restrictor configured on the PBX and assigned to the subscriber
- Authorisation in the PBX for **Controlling of the PBX via telephone**

In order to activate or deactivate the call restrictor, press the **function key** configured for the call restrictor (incoming).

Or, proceed as described in the following.

1. Press the **menu key** and open the menu **functions > Call Restrictor**.

The ● icon indicates the current setting.

2. Select the desired option:

**switch on:** Enables the call restrictor.

**switch off:** Disables the call restrictor.

## Configuring and Operating Function Key for Call Restrictor (Incoming)

Press the key to switch the subscriber's call restrictor on or off or to switch it over.

In addition, when functions are defined on the first key level, the status of the function is indicated by the corresponding LED.

### LED signalling next to the key:

Red	The call restrictor is enabled.
Off	The call restrictor is disabled.

The configuration can be carried out as follows:

- Via COMfortel Set
- Via the telephone menu

### Configuring Function Key for Call Restrictor (Incoming) via COMfortel Set

#### *Requirements:*

– An open configuration and the required PIN, if necessary

1. Open the page **Function keys > Assign function keys**.
2. Only available in installed extension modules: In the telephone displayed at the top left, click the key group in which you would like to define keys.
3. Click one of the following tabs:
  - Level 1:** Keys are defined on the first key level.
  - Level 2:** Keys are defined on the second key level.
4. Right-click the function key you want to assign.  
A function selection dialogue opens.
5. Select the **Call restrictor - incoming (Robinson no.)** function.  
The current settings for defining the key are displayed.
6. In the **Kind of switching** list field, select one of the following options:
  - switch off:** Pressing the key enables the call restrictor.
  - switch on:** Pressing the key enables the call restrictor.
  - switch over:** Pressing the key switches the call restrictor on and off.

7. In the **Key name** entry field, enter a name for the key. The following entries are possible:

Up to 16 digits

Digits and characters

Clicking  automatically enters the default name in the entry field.

---

**Note:** The key name is used for printing the label.

---

*Further steps:*

- *Save your configuration before closing.*

*Requirements for operating the function:*

- *A call restrictor configured on the PBX and assigned to the subscriber*
- *Authorisation in the PBX for **Controlling of the PBX via telephone***

### **Configuring Function Key for Call Restrictor (Incoming) via Telephone Menu**

*Requirements:*

- *Knowledge of the telephone, its menu options and the required PIN, if necessary*

1. Press the **menu key** and open the **define keys** menu.

2. Press the **function key** that you would like to define.

3. Select the desired option:

**first level:** Keys are defined on the first key level.

**second level:** Keys are defined on the second key level.

The list of available functions is displayed.



4. Select the **Call Restrictor** function.

The current settings for defining the key are shown on the display.

## Configuring and Operating Functions

Call Restrictor (Incoming) – Robinson Numbers

Configuring and Operating Function Key for Call Restrictor (Incoming)

5. Select the kind of switching. Pressing the  **softkey** allows you to switch over between the different kinds of switching.
  - switch off:** Pressing the key enables the call restrictor.
  - switch on:** Pressing the key enables the call restrictor.
  - switch over:** Pressing the key switches the call restrictor on and off.
6. Press the  **softkey** to accept the setting.

*Requirements for operating the function:*

- A call restrictor configured on the PBX and assigned to the subscriber
- Authorisation in the PBX for **Controlling of the PBX via telephone**



# Call Waiting

If you are already in a call, the call waiting function notifies you using the call waiting tone when another communication partner is calling.

---

## Switching Call Waiting On/Off

Switching this on/off can be done as follows:

- Via the telephone menu

### *Requirements:*

- *Knowledge of the telephone, its menu options and the required PIN, if necessary*
- *Authorisation in the PBX for **Controlling of the PBX via telephone***

In order to enable or disable call waiting, press the **function key** configured for call waiting.

Or, proceed as described in the following.

1. Press the **menu key** and open the menu **functions > call waiting**.

The ● icon indicates the current setting.

2. Select the desired option:

**switch on:** Enables call waiting.

**switch off:** Disables call waiting.

## Configuring and Operating Function Key for Call Waiting

Press the key to switch call waiting on or off or to switch it over.

In addition, when functions are defined on the first key level, the status of the function is indicated by the corresponding LED.

### LED signalling next to the key:

Green	Call waiting is enabled.
Off	Call waiting is disabled.

The configuration can be carried out as follows:

- Via COMfortel Set
- Via the telephone menu

### Configuring Function Key for Call Waiting via COMfortel Set

#### *Requirements:*

– An open configuration and the required PIN, if necessary

1. Open the page **Function keys > Assign function keys**.
2. Only available in installed extension modules: In the telephone displayed at the top left, click the key group in which you would like to define keys.
3. Click one of the following tabs:
  - Level 1:** Keys are defined on the first key level.
  - Level 2:** Keys are defined on the second key level.
4. Right-click the function key you want to assign.  
A function selection dialogue opens.
5. Select the **Call waiting** function.  
The current settings for defining the key are displayed.
6. In the **Kind of switching** list field, select one of the following options:
  - switch off:** Pressing the key disables call waiting.
  - switch on:** Pressing the key enables call waiting.
  - switch over:** Pressing the key switches call waiting on and off.

7. In the **Key name** entry field, enter a name for the key. The following entries are possible:

- Up to 16 digits
- Digits and characters

Clicking  automatically enters the default name in the entry field.

---

**Note:** The key name is used for printing the label.

---

*Further steps:*

- *Save your configuration before closing.*

*Requirements for operating the function:*

- *Authorisation in the PBX for **Controlling of the PBX via telephone***

### **Configuring Function Key for Call Waiting via Telephone Menu**

*Requirements:*

- *Knowledge of the telephone, its menu options and the required PIN, if necessary*

1. Press the **menu key** and open the **define keys** menu.
2. Press the **function key** that you would like to define.
3. Select the desired option:
  - first level:** Keys are defined on the first key level.
  - second level:** Keys are defined on the second key level.The list of available functions is displayed.
4. Select the **Call Waiting** function.  
The current settings for defining the key are shown on the display.
5. Select the kind of switching. Pressing the  **softkey** allows you to switch over between the different kinds of switching.
  - switch off:** Pressing the key disables call waiting.
  - switch on:** Pressing the key enables call waiting.
  - switch over:** Pressing the key switches call waiting on and off.

6. Press the **✓ softkey** to accept the setting.

*Requirements for operating the function:*

- *Authorisation in the PBX for **Controlling of the PBX via telephone***

---

## Switching Call Waiting Signalling On/Off via LED/Tone

Incoming calls during a call are indicated by a change in the display.

If call waiting signalling via LED has been enabled, incoming calls during a call are also indicated via a blinking LED above the hook key.

If call waiting signalling via tone is enabled, incoming calls during a call are also indicated by a tone on the receiver.

Switching this on/off can be done as follows:

- Via COMfortel Set
- Via the telephone menu

## Switching Call Waiting Signal via LED/Tone On/Off via COMfortel Set

*Requirements:*

- *An open configuration and the required PIN, if necessary*

1. Open the page **Settings/functions > Signalling/ringer**.
2. Select or clear the **Call waiting (LED)** check box.
  - Enables call waiting signalling via LED using the hook key.
  - Disables call waiting signalling via LED using the hook key.
3. Select or clear the **Call waiting (tone)** check box.
  - Enables call waiting signalling via tone.
  - Disables call waiting signalling via tone.

*Further steps:*

- *Save your configuration before closing.*

## **Switching Call Waiting Signalling via LED/Tone On/Off via Telephone Menu**

### *Requirements:*

– *Knowledge of the telephone, its menu options and the required PIN, if necessary*

1. Press the **menu key** and open the menu **settings > signalling > call wait. tone**.
2. Select or clear the **LED** check box.
  - Enables call waiting signalling via LED using the hook key.
  - Disables call waiting signalling via LED using the hook key.
3. Select or clear the **tone** check box.
  - Enables call waiting signalling via tone.
  - Disables call waiting signalling via tone.
4. Press the **✓ softkey** to accept the setting.

# Configuration Switchover

If multiple configurations have been saved in the PBX, for example, for day, night, etc., switching over from one configuration to another can be carried out manually and/or in a time controlled manner.

---

## Configuration Switchover Executed Manually

The execution can be made as follows:

- Via the telephone menu

### *Requirements:*

- *Knowledge of the telephone, its menu options and the required PIN, if necessary*
- *At least two configurations set up in the PBX*
- *Authorization in the PBX for **Configuration switching***

In order to switch over a configuration in the PBX, press the **function key** configured for configuration switchover.

Or, proceed as described in the following.

1. Press the **menu key** and open the menu **functions > switch config..**  
The ● icon indicates the current setting.
2. Select the desired configuration according to its name.  
The configuration selected is switched on.

## Configuring and Operating Function Key for Configuration Switchover

Press the key for general functions while the telephone is in the idle state to open the **Configuration** menu. After this, you can enable the configuration.

Press the key defined for configurations to enable the configuration that has been set up.

In addition, when functions are defined on the first key level, the status of the function is indicated by the corresponding LED.

### LED signalling next to the key (only for defined key assignment):

Green	The configuration saved in the key is enabled.
Off	The configuration saved in the key is disabled.

The configuration can be carried out as follows:

- Via COMfortel Set
- Via the telephone menu

## Configuring Function Key for General Configuration Switchover via COMfortel Set

### Requirements:

- An open configuration and the required PIN, if necessary
- At least two configurations set up in the PBX

1. Open the page **Function keys > Assign function keys**.
2. Only available in installed extension modules: In the telephone displayed at the top left, click the key group in which you would like to define keys.
3. Click one of the following tabs:
  - Level 1:** Keys are defined on the first key level.
  - Level 2:** Keys are defined on the second key level.
4. Right-click the function key you want to assign.  
A function selection dialogue opens.
5. Select the **Config. on** function.  
The current settings for defining the key are displayed.

6. In the **Key name** entry field, enter a name for the key. The following entries are possible:

Up to 16 digits

Digits and characters

Clicking  automatically enters the default name in the entry field.

---

**Note:** The key name is used for printing the label.

---

*Further steps:*

- *Save your configuration before closing.*

*Requirements for operating the function:*

- *Authorization in the PBX for **Configuration switching***

### **Configuring Function Key for Defined Configuration Switchover via COMfortel Set**

*Requirements:*

- *An open configuration and the required PIN, if necessary*
- *At least two configurations set up in the PBX*

1. Open the page **Function keys > Assign function keys**.
2. Only available in installed extension modules: In the telephone displayed at the top left, click the key group in which you would like to define keys.
3. Click one of the following tabs:
  - Level 1:** Keys are defined on the first key level.
  - Level 2:** Keys are defined on the second key level.
4. Right-click the function key you want to assign.  
A function selection dialogue opens.
5. Select the **Defined config. on** function.  
The current settings for defining the key are displayed.
6. Configure the settings dependent on the type of PBX.



- Select a configuration in the **configuration to be activated** list field.
  - Enter the identification number of the configuration in the **identification number** field.
7. In the **Key name** entry field, enter a name for the key. The following entries are possible:
- Up to 16 digits
  - Digits and characters

Clicking  automatically enters the default name in the entry field.

---

**Note:** The key name is used for printing the label and for display.

---

*Further steps:*

- *Save your configuration before closing.*

*Requirements for operating the function:*

- *Authorization in the PBX for **Configuration switching***

### **Configuring Function Key for Configuration Switchover via Telephone Menu**

*Requirements:*

- *Knowledge of the telephone, its menu options and the required PIN, if necessary*
- *At least two configurations set up in the PBX*

1. Press the **menu key** and open the **define keys** menu.
2. Press the **function key** that you would like to define.
3. Select the desired option:
  - first level:** Keys are defined on the first key level.
  - second level:** Keys are defined on the second key level.

The list of available functions is displayed.



4. Select the **switch config.** function.

The current settings for defining the key are shown on the display.

5. Select the kind of key. Press the  **softkey** to switch over between the different kinds of keys.

**general:** Press the key to open the **switch configuration** menu. (No other action is required.)

**defined:** Press the key to enable the set configuration.

6. Press the  **softkey**.
7. Select a configuration based on its name.
8. Press the  **softkey** to accept the setting.

*Requirements for operating the function:*

– *Authorization in the PBX for **Configuration switching***

## Do-not-disturb

The do-not-disturb function offers the option of blocking internal and external calls as well as blocking group calls on a specific telephone. A caller hears only a busy signal. An internal subscriber can reach a telephone with call protection in an emergency using a priority call.

The do-not-disturb function has no influence on outbound calls, callbacks, alarm calls, scheduled calls, wake-up calls or InterCom calls.

---

### Switching the Do-not-disturb Function On/Off

Switching this on/off can be done as follows:

- Via the telephone menu

#### *Requirements:*

- Knowledge of the telephone, its menu options and the required PIN, if necessary
- Authorisation in the PBX for **Controlling of the PBX via telephone**

In order to activate or deactivate the do-not-disturb function, press the **function key** configured for do-not-disturb.

Or, proceed as described in the following.

1. Press the **menu key** and open the menu **functions > do-not-disturb**.

The ● icon indicates the current setting.

2. Select the desired option:

**switch on:** Enables the do-not-disturb function.

**switch off:** Disables the do-not-disturb function.

## Configuring and Operating Function Key for Do-not-disturb

Press the key to switch the do-not-disturb function on or off or to switch it over.

In addition, when functions are defined on the first key level, the status of the function is indicated by the corresponding LED.

### LED signalling next to the key:

Yellow	The do-not-disturb function is enabled.
Off	The do-not-disturb function is disabled.

The configuration can be carried out as follows:

- Via COMfortel Set
- Via the telephone menu

### Configuring Function Key for Do-not-disturb via COMfortel Set

*Requirements:*

– An open configuration and the required PIN, if necessary

1. Open the page **Function keys > Assign function keys**.
2. Only available in installed extension modules: In the telephone displayed at the top left, click the key group in which you would like to define keys.
3. Click one of the following tabs:
  - Level 1:** Keys are defined on the first key level.
  - Level 2:** Keys are defined on the second key level.
4. Right-click the function key you want to assign.  
A function selection dialogue opens.
5. Select the **Do-not-disturb** function.  
The current settings for defining the key are displayed.
6. In the **Kind of switching** list field, select one of the following options:
  - switch off:** Disables the do-not-disturb function.

**switch on:** Enables the do-not-disturb function.

**switch over:** Pressing the key switches the do-not-disturb function on and off.

7. In the **Key name** entry field, enter a name for the key. The following entries are possible:

Up to 16 digits

Digits and characters

Clicking  automatically enters the default name in the entry field.

---

**Note:** The key name is used for printing the label.

---

*Further steps:*

- *Save your configuration before closing.*

*Requirements for operating the function:*

- *Authorisation in the PBX for **Controlling of the PBX via telephone***

### **Configuring Function Key for Do-not-disturb via Telephone Menu**

*Requirements:*

- *Knowledge of the telephone, its menu options and the required PIN, if necessary*

1. Press the **menu key** and open the **define keys** menu.
2. Press the **function key** that you would like to define.
3. Select the desired option:



**first level:** Keys are defined on the first key level.

**second level:** Keys are defined on the second key level.

The list of available functions is displayed.

4. Select the **do-not-disturb** function.

The current settings for defining the key are shown on the display.

5. Select the kind of switching. Pressing the  **softkey** allows you to switch over between the different kinds of switching.
  - switch off:** Disables the do-not-disturb function.
  - switch on:** Enables the do-not-disturb function.
  - switch over:** Pressing the key switches the do-not-disturb function on and off.
6. Press the  **softkey** to accept the setting.

*Requirements for operating the function:*

- Authorisation in the PBX for **Controlling of the PBX via telephone**

---

## Configuring Type of Do-not-disturb

Defining the type of Do-not-disturb function determines how do-not-disturb works when it is enabled.

The configuration can be made as follows:

- Via COMfortel Set
- Via the telephone menu

### Configuring Type of Do-not-disturb via COMfortel Set

*Requirements:*

- An open configuration and the required PIN, if necessary

1. Open the page **Settings/functions > Do-not-disturb**.
2. Under **Kind of do-not-disturb**, select one of the following options:
  - All (PBX):** The do-not-disturb function is carried out via the PBX. All incoming calls are rejected and not entered in the caller list on the telephone.
  - Reject anonymous:** All anonymous calls are rejected.

**Only contacts:** All calls are rejected except for calls from contacts listed in the telephone book.

**All (telephone):** The do-not-disturb function is carried out via the phone. All incoming calls are rejected and entered in the caller list on the telephone.

---

**Note:**

Parallel to the kind of do-not-disturb, **All (PBX)**, the call deblocker (incoming) can be enabled so that the VIP numbers registered in the call deblocker on the PBX are not rejected.

Internal telephone calls are only rejected if the kind of do-not-disturb function **All (PBX)** and **All (telephone)** are used. An internal subscriber can reach a protected telephone in an emergency with a priority call if the kind of do-not-disturb function **All (PBX)** is used. Calls are only registered in the caller list on the telephone if the kind of do-not-disturb function **All (telephone)** is used.

---

*Further steps:*

- *Save your configuration before closing.*

### **Configuring Type of Do-not-disturb via Telephone Menu**

*Requirements:*

- *Knowledge of the telephone, its menu options and the required PIN, if necessary*

1. Press the **menu key** and open the menu **settings > do-not-disturb > kind do-not-dist.**

The ● icon indicates the current setting.

2. Select the desired option:

**all (PBX):** The do-not-disturb function is carried out via the PBX. All incoming calls are rejected and not entered in the caller list on the telephone.

**reject anonymous:** All anonymous calls are rejected.

**only contacts:** All calls are rejected except for calls from contacts listed in the telephone book.

**all (telephone):** The do-not-disturb function is carried out via the phone. All incoming calls are rejected and entered in the caller list on the telephone.

---

**Note:**

Parallel to the kind of do-not-disturb, **all (PBX)**, the call deblocker (incoming) can be enabled so that the VIP numbers registered in the call deblocker on the PBX are not rejected.

Internal telephone calls are only rejected if the kind of do-not-disturb function **all (PBX)** and **all (telephone)** are used. An internal subscriber can reach a protected telephone in an emergency with a priority call if the kind of do-not-disturb function **all (PBX)** is used. Calls are only registered in the caller list on the telephone if the kind of do-not-disturb function **all (telephone)** is used.

---



## Door Functions

A door terminal system connected with the interface FTZ 123 D12-0 (PBX requires extension module) enables the following functions. Calls to the door can be made from any telephone (intercom). During a call to the door, the door can be opened (open door) and a stairwell light controlled by switching a relay (switch on light).

These functions can be executed on the system telephone without initiating a door call.

---

### Executing Door Functions

---

**Important:** Not available for operation on the PBX COMpact 3000.

---

The execution can be made as follows:

- Via the telephone menu

*Requirements:*

- Knowledge of the telephone, its menu options and the required PIN, if necessary
- The authority level assigned in the PBX for the door terminal
- The relays configured in the PBX for the intercom, opening the door and the stairwell light
- Authorization in the PBX for **Open door**

In order to operate the door functions, press the **function key** configured for door functions.

Or, proceed as described in the following.

1. Press the **menu key** and open the menu **functions > door function**.
2. Select the desired door based on its name/number.
3. Select the desired option:

**open door/light:** Opens the door and switches the stairwell light on.

**open door:** Opens the door.

**light on:** Switches the stairwell light on.

**talk:** Establishes a call connection to the door.

---

**Note:** The door function **light on** switches on the third relay of the door terminal in question separately for the period configured in the PBX.

---

### **Own Telephone Rings (Door Call) – Accept Call and Open Door**

The accepting/opening procedure can be carried out as follows:

- Via the telephone menu

#### *Requirements:*

- *Knowledge of the telephone, its menu options and the required PIN, if necessary*
- *The authority level assigned in the PBX for the door terminal*
- *The relays configured in the PBX for the intercom, opening the door and the stairwell light*
- *Authorization in the PBX for **Open door***

Proceed as described further down if you receive a door call.

1. Pick up the receiver or press the **Hook key**.
2. Select **open door/light**.

The door is opened. If the third relay of the door terminal in question is used for switching the stairwell light, this is also switched on for the period configured in the PBX.

### **The door knocks – open the door without accepting the call**

During a call, you can handle an incoming door call generally as you would an incoming external subscriber. This means that you can accept the call, reject it or ignore it. In addition, you can, if you do not want to interrupt your current call, still open the door for the visitor by pressing the door opener.

Opening can be carried out as follows:

- Via the telephone menu

*Requirements:*

- Knowledge of the telephone, its menu options and the required PIN, if necessary
- The authority level assigned in the PBX for the door terminal
- The relays configured in the PBX for the intercom, opening the door and the stairwell light
- Authorization in the PBX for **Open door**

Proceed as described when a door calls.

- Select **open door/light**.

The door is opened. If the third relay of the door terminal in question is used for switching the stairwell light, this is also switched on for the period configured in the PBX.

---

## Configuring and Operating Function Key for Door Functions

---

**Important:** Not available for operation on the PBXs COMpact 2204 USB and COMpact 3000.

---

Press the key for general functions while the telephone is in the idle state to open the **door function** menu. After this, you can initiate a door function for the configured door.

Press the key defined to initiate a call connection with the door (after picking up the receiver) or to switch on the door opener and/or light.

In addition, when functions are defined on the first key level, the status of the function is indicated by the corresponding LED.

**LED signalling next to the key:**

Green	The door opener function is enabled.
Red	A call connection has been established with the door.
Yellow	The light is switched on.
Off	None of the functions configured on the key are enabled.

The configuration can be carried out as follows:

- Via COMfortel Set
- Via the telephone menu

### **Configuring Function Key for Door Terminal Functions via COMfortel Set**

*Requirements:*

- An open configuration and the required PIN, if necessary
- The authority level assigned in the PBX for the door terminal
- The relays configured in the PBX for the intercom, opening the door and the stairwell light

1. Open the page **Function keys > Assign function keys**.
2. Only available in installed extension modules: In the telephone displayed at the top left, click the key group in which you would like to define keys.
3. Click one of the following tabs:
  - Level 1:** Keys are defined on the first key level.
  - Level 2:** Keys are defined on the second key level.
4. Right-click the function key you want to assign.  
A function selection dialogue opens.
5. Select the **Door terminal function** function.  
The current settings for defining the key are displayed.
6. In the **Telephone no** entry field, enter the telephone number of the door.
7. In the **Key name** entry field, enter a name for the key. The following entries are possible:
  - Up to 16 digits
  - Digits and characters

Clicking  automatically enters the default name in the entry field.

---

**Note:** The key name is used for printing the label and for display.

---

*Further steps:*

- *Save your configuration before closing.*

*Requirements for operating the function:*

- *Authorization in the PBX for **Open door***

### **Configuring Function Key for Defined Door Terminal Functions via COMfortel Set**

*Requirements:*

- *An open configuration and the required PIN, if necessary*
- *The authority level assigned in the PBX for the door terminal*
- *The relays configured in the PBX for the intercom, opening the door and the stairwell light*

1. Open the page **Function keys > Assign function keys**.
2. Only available in installed extension modules: In the telephone displayed at the top left, click the key group in which you would like to define keys.
3. Click one of the following tabs:
  - Level 1:** Keys are defined on the first key level.
  - Level 2:** Keys are defined on the second key level.
4. Right-click the function key you want to assign.  
A function selection dialogue opens.
5. Select the **Defined door function** function.  
The current settings for defining the key are displayed.
6. In the **Telephone no** entry field, enter the telephone number of the door.
7. In the **Door terminal function** list field, select one of the following options:
  - Open the door & switch on the light:** Press the key to switch the door opener and the light on.
  - Open the door:** Press the key to switch the door opener on.
  - Light on:** Press the key to switch the light on.
  - Talking:** Press the key to initiate a call connection to the door.

---

**Note:** The door terminal function **Light on** switches on the third relay of the door station in question separately at the time configured in the PBX.

---

8. In the **Key name** entry field, enter a name for the key. The following entries are possible:

Up to 16 digits

Digits and characters

Clicking  automatically enters the default name in the entry field.

---

**Note:** The key name is used for printing the label and for display.

---

*Further steps:*

- *Save your configuration before closing.*

*Requirements for operating the function:*

- *Authorization in the PBX for **Open door***

### **Configuring Function Key for Door Function via Telephone Menu**

*Requirements:*

- *Knowledge of the telephone, its menu options and the required PIN, if necessary*
- *The authority level assigned in the PBX for the door terminal*
- *The relays configured in the PBX for the intercom, opening the door and the stairwell light*

1. Press the **menu key** and open the **define keys** menu.
2. Press the **function key** that you would like to define.
3. Select the desired option:
  - first level:** Keys are defined on the first key level.
  - second level:** Keys are defined on the second key level.The list of available functions is displayed.
4. Select the **door function** function.

The current settings for defining the key are shown on the display.

5. Select the kind of key. Press the  **softkey** to switch over between the different kinds of keys.

**general:** Press the key to open the **door function** menu for the door configured.

**defined:** Press the key to execute the configured door function for the configured door.

6. Only when the kind of key **defined** has been selected: Select the door function. Press the  **softkey** to switch over between the different kinds of door functions.

**open door/light:** Press the key to switch the door opener and the light on.

**open door:** Press the key to switch the door opener on.



**light on:** Press the key to switch the light on.

**talk:** Press the key to initiate a call connection to the door.

---

**Note:** The door terminal function **Light on** switches on the third relay of the door station in question separately at the time configured in the PBX.

---

7. Press the  **softkey**.
8. Select a door based on its name/number.
9. Press the  **softkey**.
10. Enter a new name for the door. The following entries are possible:
  - Up to 16 digits
  - Digits and characters
11. Press the  **softkey** to accept the setting.

*Requirements for operating the function:*

– *Authorization in the PBX for **Open door***

## Exchange Line Transfer

A suitably authorised telephone, for example, the telephone exchange, can transfer the exchange line access required for an outgoing call to another internal telephone for a short period of time. This is meaningful, for example, when this telephone is located in a publicly accessible room and is only occasionally used for external calls by an employee.

---

### Exchange Line Transfer Sequence

The exchange line transfer proceeds as follows:

- The requesting telephone must initiate an internal call with the telephone authorised to make the exchange in order to request exchange line access.

---

**Important:**

For an exchange line transfer, the telephone making the transfer needs the authority level itself to transfer external calls externally.

The requesting telephone needs at least the official exchange line authority level for incoming external calls.

---

- After the function key assigned to exchange line transfer has been pressed on the telephone authorised for making exchanges, a confirmation tone is issued to both internal subscribers and the internal call must be ended.
- The requesting telephone now has access to the exchange line settings configured for this purpose on the PBX. These exchange line settings remain until the first successful, outgoing external call or until the time limitation has elapsed for initiating the external call.

---

**Note:** Configuring the exchange line transfer function is done in the PBX.

---



---

## Configuring and Operating Function Key for Exchange Line Transfer

---

**Important:** Only available for operation on the PBXs COMpact 3000, COMpact 5010 VoIP, COMpact 5020 VoIP, COMmander Basic.2 and COMmander Business.

---

Press the key during an internal call to transfer the exchange line access to your communication partner for a single external call. Afterwards, a confirmation tone is issued on both internal telephones and the internal call must be ended.

### LED signalling next to the key:

None

The configuration can be carried out as follows:

- Via COMfortel Set
- Via the telephone menu

### Configuring Function Key for Exchange Line Transfer via COMfortel Set

#### *Requirements:*

– An open configuration and the required PIN, if necessary

1. Open the page **Function keys > Assign function keys**.
2. Only available in installed extension modules: In the telephone displayed at the top left, click the key group in which you would like to define keys.
3. Click one of the following tabs:
  - Level 1:** Keys are defined on the first key level.
  - Level 2:** Keys are defined on the second key level.
4. Right-click the function key you want to assign.  
A function selection dialogue opens.
5. Select the **Exchange line call transfer** function.  
The current settings for defining the key are displayed.

6. In the **Key name** entry field, enter a name for the key. The following entries are possible:

- Up to 16 digits
- Digits and characters

Clicking  automatically enters the default name in the entry field.

---

**Note:** The key name is used for printing the label.

---

*Further steps:*

- *Save your configuration before closing.*

*Requirements for operating the function:*

- *Authorization in the PBX for **Transfer of external calls to external***

### **Configuring Function Key for Exchange Line Transfer via Telephone Menu**

*Requirements:*

- *Knowledge of the telephone, its menu options and the required PIN, if necessary*

1. Press the **menu key** and open the **define keys** menu.
2. Press the **function key** that you would like to define.
3. Select the desired option:
  - first level:** Keys are defined on the first key level.
  - second level:** Keys are defined on the second key level.

The list of available functions is displayed.

4. Select the **ext. line transfer** function.

The current settings for defining the key are shown on the display.
5. Press the  **softkey** to accept the setting.

*Requirements for operating the function:*

- *Authorization in the PBX for **Transfer of external calls to external***

## Follow me

Follow me is a type of "internal call forwarding unconditional for subscribers" that is configured on the respective destination telephone (instead of on the forwarding telephone). This provides the option of going from room to room and taking the calls with you.

---

### Switching Follow me On/Off

---

**Important:** Not available for operation on the PBX COMpact 3000.

---

Switching this on/off can be done as follows:

- Via the telephone menu

#### *Requirements:*

- Knowledge of the telephone, its menu options and the required PIN, if necessary
- Authorisation in the PBX for **Controlling of the PBX via telephone**

1. Press the **menu key** and open the menu **functions > follow me**.

Or, press a **function key** configured for Follow me.

2. Select the desired option:

**deactivate all:** Disables all of the currently enabled Follow me functions. (No other action is required.)

**switch on:** Enables Follow me for a subscriber.

**switch off:** Disables follow me for a subscriber.

---

**Note:** For operation on the PBXs COMpact 2204 USB, COMpact 2206 USB, COMpact 4406 DSL, COMpact 4410 USB and COMmander Basic, it is not possible to switch off the follow-me function for a single subscriber. For this reason, the **switch off** option is not available. The **switch on** option, on the other hand, is replaced by the following step.

---

3. Select the subscriber whose calls should be rerouted using his name/number.

---

**Note:** Follow me can also be disabled on the forwarded telephone by using "Switch off follow-me" for the subscriber's own telephone number (for operation on the PBXs COMpact 5010 VoIP, COMpact 5020 VoIP, COMmander Basic.2 and COMmander Business) or "CF subscriber" (for operation on the PBXs COMpact 2204 USB, COMpact 2206 USB, COMpact 4406 DSL, COMpact 4410 USB and COMmander Basic).

---

---

## Configuring and Operating Function Key for Follow me

---

**Important:** Not available for operation on the PBX COMpact 3000.

---

Press the key while the telephone is in the idle state to open the **follow me** menu. This allows you to switch follow me on or off or to switch it over for an internal subscriber.

### LED signalling next to the key:

None

The configuration can be carried out as follows:

- Via COMfortel Set
- Via the telephone menu

### Configuring Function Key for Follow-me via COMfortel Set

*Requirements:*

– *An open configuration and the required PIN, if necessary*

1. Open the page **Function keys > Assign function keys**.
2. Only available in installed extension modules: In the telephone displayed at the top left, click the key group in which you would like to define keys.

3. Click one of the following tabs:
  - Level 1:** Keys are defined on the first key level.
  - Level 2:** Keys are defined on the second key level.
4. Right-click the function key you want to assign.  
A function selection dialogue opens.
5. Select the **Follow me** function.  
The current settings for defining the key are displayed.
6. In the **Key name** entry field, enter a name for the key. The following entries are possible:
  - Up to 16 digits
  - Digits and characters

Clicking  automatically enters the default name in the entry field.

---

**Note:** The key name is used for printing the label.

---

*Further steps:*

- *Save your configuration before closing.*

*Requirements for operating the function:*

- *Authorisation in the PBX for **Controlling of the PBX via telephone***

### **Configuring Function Key for Follow me via Telephone Menu**

*Requirements:*

- *Knowledge of the telephone, its menu options and the required PIN, if necessary*

1. Press the **menu key** and open the **define keys** menu.
2. Press the **function key** that you would like to define.

3. Select the desired option:

**first level:** Keys are defined on the first key level.

**second level:** Keys are defined on the second key level.

The list of available functions is displayed.

4. Select the **follow me** function.

The current settings for defining the key are shown on the display.

5. Press the **✓ softkey** to accept the setting.

*Requirements for operating the function:*

– *Authorisation in the PBX for **Controlling of the PBX via telephone***

## Group Functions

In addition to internal subscribers, the PBX can also manage groups. The internal subscribers can become members of any and all groups. These groups can be used, for example, to collect the internal subscribers in certain departments or teams (Support, Marketing, Sales) together.

Membership in a group does not necessarily mean that a subscriber receives calls sent to the group. A subscriber that is logged out takes on no group functions. This can be especially important for employees of a support department, who should not be available to customers around the clock, but rather rotate in and out of the hotline.

---

### Detailed Information about Group Functions

---

**Important:** Not available for operation on the PBX COMpact 3000.

**Note:**

If a group (subgroup) has been configured in the PBX as member of a group (main group) and a subscriber is at the same time member of these two groups, he will only be considered as a member of the main group when a call comes in.

Subgroups (i.e. groups that have been configured as members of other groups) are "permanently logged in as incoming" and "permanently logged out as outgoing" in the corresponding main group.

---

There are three different ways to logon:

#### Only incoming

When logging into a group as "incoming", the subscriber then finds himself in the call distribution of the group in question for internal, exchange line and door calls.

#### Only outgoing

When logging into a group as "outgoing", the subscriber acquires a number of characteristics/access rights from the group. These replace his own characteristics/access rights as an individual subscriber for outgoing work-related calls. A subscriber can only be logged on in a single group as "outgoing" even if he is a member of more than one group.

---

**Note:** If a subscriber logs into different groups as "outgoing" one after the other, he will only remain logged in as "outgoing" in the group that he logged into last.

---

### Incoming and outgoing

When logging into a group as "incoming and outgoing", the subscriber then finds himself in the call distribution of the group in question for internal, exchange line and door calls and also acquires a number of additional characteristics/access rights from the group. These replace his own characteristics/permissions as an individual subscriber for outgoing work-related calls.

---

**Note:** If a subscriber logs into more than one group as "incoming and outgoing", he will only remain logged in as "incoming and outgoing" in the group that he logged into last. And in all other groups, he is then only "logged in as incoming".

---

---

## Logging the Telephone In/Out

The log in/out can be carried out as follows:

- Via the telephone menu

### *Requirements:*

- *Knowledge of the telephone, its menu options and the required PIN, if necessary*
- *The telephone is a member of a group configured in the PBX*
- *Authorisation in the PBX for **Controlling of the PBX via telephone***

In order to log a telephone into a group and or out of it, press the **function key** configured for group functions.

Or, proceed as described in the following.

1. Press the **menu key** and open the menu **functions > group**.
2. Select the desired group based on its name/number.



3. Select the desired option:

**logging in:** Logs the telephone into the group.

**log out:** Logs the telephone out of the group.

4. Select the desired option:

**outgoing:** Select the type of call for outgoing.

**inbound:** Select the type of call for incoming.

**inbound & outbnd:** Selects the type of call for inbound & outbound.

---

## Logging Telephone Out of All Groups

The log out can be carried out as follows:

- Via the telephone menu

### *Requirements:*

- Knowledge of the telephone, its menu options and the required PIN, if necessary
- The telephone is a member of a group configured in the PBX
- Authorisation in the PBX for **Controlling of the PBX via telephone**

In order to log out of all groups, press the **function key** configured for logging out of all groups.

Or, proceed as described in the following.

- Press the **menu key** and open the menu **Functions > log out all grp..**

---

## Configuring and Operating Function Key for Group Function

Press the key for general functions while the telephone is the idle state to open the menu for logging in or out of a specified group. After making the selection, you still need to specify the type of call (incoming, outgoing or incoming & outgoing).

Press the defined key to execute the action configured in the key for the specified group.

In addition, when functions are defined on the first key level, the status of the function is indicated by the corresponding LED.

**LED signalling next to the key:**

Green	The telephone is logged into the group for incoming and outgoing calls.
Yellow	The telephone is only logged into the group for either incoming or outgoing calls.
Off	The telephone is logged out of the group.

**LED signalling next to the key (when defined with a specific group function only incoming):**

Green	The telephone is logged into the group for incoming and outgoing calls.
Yellow	The telephone is only logged into the group for incoming calls.
Off	The telephone is logged out of the group for incoming calls.

**LED signalling next to the key (when defined with a specific group function only outgoing):**

Green	The telephone is logged into the group for outgoing and incoming calls.
Yellow	The telephone is only logged into the group for outgoing calls.
Off	The telephone is logged out of the group for outgoing calls.

The configuration can be carried out as follows:

- Via COMfortel Set
- Via the telephone menu

**Configuring Function Key for General Group Functions via COMfortel Set**

*Requirements:*

- An open configuration and the required PIN, if necessary
- The telephone is a member of a group configured in the PBX

1. Open the page **Function keys > Assign function keys**.
2. Only available in installed extension modules: In the telephone displayed at the top left, click the key group in which you would like to define keys.

3. Click one of the following tabs:
  - Level 1:** Keys are defined on the first key level.
  - Level 2:** Keys are defined on the second key level.
4. Right-click the function key you want to assign.  
A function selection dialogue opens.
5. Select the **Group** function.  
The current settings for defining the key are displayed.
6. In the **Telephone no** entry field, enter the telephone number of the group.
7. In the **Key name** entry field, enter a name for the key. The following entries are possible:
  - Up to 16 digits
  - Digits and characters

Clicking  automatically enters the default name in the entry field.

---

**Note:** The key name is used for printing the label and for display.

---

*Further steps:*

- *Save your configuration before closing.*

*Requirements for operating the function:*

- *Authorisation in the PBX for **Controlling of the PBX via telephone***

### **Configuring Function Key for Defined Group Functions via COMfortel Set**

*Requirements:*

- *An open configuration and the required PIN, if necessary*
- *The telephone is a member of a group configured in the PBX*

1. Open the page **Function keys > Assign function keys**.
2. Only available in installed extension modules: In the telephone displayed at the top left, click the key group in which you would like to define keys.

3. Click one of the following tabs:
  - Level 1:** Keys are defined on the first key level.
  - Level 2:** Keys are defined on the second key level.
4. Right-click the function key you want to assign.  
A function selection dialogue opens.
5. Select the **Defined group** function.  
The current settings for defining the key are displayed.
6. In the **Telephone no** entry field, enter the telephone number of the group.
7. In the **action** list field, select one of the following options:
  - Log out:** Press the key to log the telephone out of the group.
  - Log in:** Press the key to log the telephone into the group.
  - Change logging:** Press the key to change the log in status.
8. In the **direction** list field, select one of the following options:
  - incoming:** Select the type of call for incoming.
  - outgoing:** Select the type of call for outgoing.
  - inbound + outbound:** Select the type of call for inbound + outbound.
9. In the **Key name** entry field, enter a name for the key. The following entries are possible:
  - Up to 16 digits
  - Digits and characters

Clicking  automatically enters the default name in the entry field.

---

**Note:** The key name is used for printing the label and for display.

---

*Further steps:*

- *Save your configuration before closing.*

*Requirements for operating the function:*



- *Authorisation in the PBX for **Controlling of the PBX via telephone***

## Configuring Function Key for Group Functions via Telephone Menu

### Requirements:

- Knowledge of the telephone, its menu options and the required PIN, if necessary
- The telephone is a member of a group configured in the PBX

1. Press the **menu key** and open the **define keys** menu.
2. Press the **function key** that you would like to define.
3. Select the desired option:
  - first level:** Keys are defined on the first key level.
  - second level:** Keys are defined on the second key level.The list of available functions is displayed.
4. Select the **group** function.  
The current settings for defining the key are shown on the display.
5. Select the kind of key. Press the ↻ **softkey** to switch over between the different kinds of keys.
  - general:** Press the key to select the action and direction of the group configured.
  - defined:** Executes the action specified for the group configured.
6. Press the ☒ **softkey**.
7. Select a group based on its name/number.
8. Press the ☒ **softkey**.
9. Enter a name for the group. The following entries are possible:
  - Up to 16 digits
  - Digits and characters
10. Only when the kind of key **defined** has been selected: Select the action. Press the ↻ **softkey** to switch over between the different actions.
  - log out:** Press the key to log the telephone out of the group.
  - logging in:** Press the key to log the telephone into the group.
  - log over:** Press the key to change the log in status.

11. Only when the kind of key **defined** has been selected: Select the direction. Press the  **softkey** to switch over between the different directions.
  - inbound**: Select the type of call for incoming.
  - outgoing**: Select the type of call for outgoing.
  - inbound & outbnd**: Selects the type of call for incoming and outgoing.
12. Press the  **softkey** to accept the setting.

*Requirements for operating the function:*

- Authorisation in the PBX for **Controlling of the PBX via telephone**

---

## Configuring and Operating Function Key for Logging Out of All Groups

Press the key while the telephone is in the idle state to log the telephone out of all groups.

### LED signalling next to the key:

None

The configuration can be carried out as follows:

- Via COMfortel Set
- Via the telephone menu

### Configuring Function Key for Logging Out of All Groups via COMfortel Set

*Requirements:*

- An open configuration and the required PIN, if necessary
- The telephone is a member of a group configured in the PBX

1. Open the page **Function keys > Assign function keys**.
2. Only available in installed extension modules: In the telephone displayed at the top left, click the key group in which you would like to define keys.

3. Click one of the following tabs:
  - Level 1:** Keys are defined on the first key level.
  - Level 2:** Keys are defined on the second key level.
4. Right-click the function key you want to assign.  
A function selection dialogue opens.
5. Select the **Group functions off** function.  
The current settings for defining the key are displayed.
6. In the **Key name** entry field, enter a name for the key. The following entries are possible:
  - Up to 16 digits
  - Digits and characters

Clicking  automatically enters the default name in the entry field.

---

**Note:** The key name is used for printing the label.

---

*Further steps:*

- *Save your configuration before closing.*

*Requirements for operating the function:*

- *Authorisation in the PBX for **Controlling of the PBX via telephone***

### **Configuring Function Key for Logging Out of All Groups via Telephone Menu**

*Requirements:*

- *Knowledge of the telephone, its menu options and the required PIN, if necessary*
- *The telephone is a member of a group configured in the PBX*

1. Press the **menu key** and open the **define keys** menu.
2. Press the **function key** that you would like to define.

3. Select the desired option:
  - first level:** Keys are defined on the first key level.
  - second level:** Keys are defined on the second key level.The list of available functions is displayed.
4. Select the **log out all grp.** function.  
The current settings for defining the key are shown on the display.
5. Press the **✓ softkey** to accept the setting.

*Requirements for operating the function:*

- *Authorisation in the PBX for **Controlling of the PBX via telephone***

---

## Configuring and Operating the Display of the Group Status

Press the key in the idle mode of the telephone to display the current group status of the subscribers (logged out, logged in as incoming and/or outgoing) on the LEDs of configured speed dialling keys for approx. ten seconds. For this purpose, the speed dialling keys must be assigned to the corresponding subscriber telephone numbers. Press the key again during the ten seconds to cancel the display.

### **LED signalling next to the key:**

Blinking yellow      The group status is being queried.

### **LED signalling next to the speed dialling keys assigned to subscriber telephone numbers:**

Red                  The telephone is logged out of the group.  
Green                The telephone is logged into the group for incoming and outgoing calls.  
Yellow                The telephone is logged into the group for incoming calls.  
Blinking yellow     The telephone is logged into the group for outgoing calls.



The configuration can be carried out as follows:

- Via COMfortel Set
- Via the telephone menu

### **Configuring Function Key for Displaying the Group Status via COMfortel Set**

*Requirements:*

– *An open configuration and the required PIN, if necessary*

1. Open the page **Function keys > Assign function keys**.
2. Only available in installed extension modules: In the telephone displayed at the top left, click the key group in which you would like to define keys.
3. Click one of the following tabs:
  - Level 1:** Keys are defined on the first key level.
  - Level 2:** Keys are defined on the second key level.
4. Right-click the function key you want to assign.  
A function selection dialogue opens.
5. Select the **Group status** function.  
The current settings for defining the key are displayed.
6. In the **Telephone no** entry field, enter the phone number of the group.
7. In the **Key name** entry field, enter a name for the key. The following entries are possible:
  - Up to 16 digits
  - Digits and characters

Clicking  automatically enters the default name in the entry field.

---

**Note:** The key name is used for printing the label and for display.

---

*Further steps:*

– *Save your configuration before closing.*



*Requirements for operating the function:*

- *Speed dialling keys assigned to the corresponding subscriber telephone numbers*

### **Configuring Function Key for Displaying the Group Status via Telephone Menu**

*Requirements:*

- *Knowledge of the telephone, its menu options and the required PIN, if necessary*

1. Press the **menu key** and open the **Define keys** menu.
2. Press the **function key** that you would like to define.
3. Select the desired option:
  - First level:** Keys are defined on the first key level.
  - Second level:** Keys are defined on the second key level.The list of available functions is displayed.
4. Select the **Group status** function.  
The current settings for defining the key are shown on the display.
5. Press the  **softkey**.
6. Select a group based on its name/number.
7. Press the  **softkey**.
8. Enter a name for the group. The following entries are possible:
  - Up to 16 digits
  - Digits and characters
9. Press the  **softkey** to accept the setting.

*Requirements for operating the function:*

- *Speed dialling keys assigned to the corresponding subscriber telephone numbers*

# Hotel Function

The hotel function allow you to conveniently manage room and call data when the PBX is used in a hotel.

---

## Function Areas of the Hotel Function

The range of features in the hotel function can be divided into the following three areas:

### Hotel reception telephones

Via the display and the LEDs on the function keys, the hotel reception telephone supports various control and query functions thereby making the need of a PC at the reception unnecessary. A function key is configured on the reception telephone for each room. In addition to check-in and check-out, other functions are available.

Before check-in, the status of the room can be checked (cleaned, unclean, blocked) and changed.

As soon as check-in is complete, the following configuration and query functions can be used.

- Call charge queries including check-in date
- Interim call charge calculation printout
- Wake-up time configuration
- External access block
- Check-out

### Room telephones

The PBX provides a variety of functions that may not be suitable or may even be harmful in relation to room telephone usage. Therefore, telephones configured as room telephones are blocked from not only programming functions (for example, do-not-disturb, call forwarding) but also from switching functions and special types of call initiation. This means that guests can only make and except calls. Furthermore, cleaning personnel have the option of indicating the status of the room by entering a series of numbers (cleaned, unclean, blocked).

The advantages of a system telephone compared to using standard telephones include centrally controlled delete functions when a guest checks out (data protection) as well as various convenience functions, and specially configured function keys when necessary. The functions that are still permitted on room telephones are operated in the exact same way as is

described for normal telephones. With one exception: A function key assigned to the hotel room function enables the guest to set a wake-up time as well as query his call charges and his check-in time.

The following functions are still possible:

- Making and excepting internal and external calls
- Deleting data and call charges using the **Functions** menu command (this does not affect the call charge counter on the PBX)
- The use of the caller/call/redial list as well as of the telephone book (parts of the telephone book can be blocked in the telephone)
- Scheduled call/reminders and power dialling
- Call charge query and wake-up time configuration using a function key

### Print function

This print function enables a printout of the guest's call charges up to that point as an invoice (or interim invoice) including an itemised list of the individual calls. This function is controlled by the hotel reception telephone.

---

**Note:** The recommended printers are listed in the manual for the PBX in question.

---

---

## Configuring the Hotel Function

---

**Important:** Only available for operation on the PBXs COMpact 4406 DSL, COMpact 4410 USB, COMmander Basic, COMpact 5020 VoIP, COMmander Basic.2 and COMmander Business.

---

The hotel function is configured as described in the following.

- For operation on the PBXs COMpact 5020 VoIP, COMmander Basic.2 and COMmander Business: Use the configuration manager on the PBX to activate the hotel function.

---

**Important:** Activating is done with an activation code that you can acquire from the Auerswald Upgrade Centre. For operation on the PBXs, COMmander Business and COMmander Basic.2, the number of available hotel telephones (reception and room telephones) must be activated. For operation on the PBX, COMpact 5020 VoIP, the hotel function only needs to be activated once.

---

- Use the configuration manager or configuration software on the PBX to select the telephones that are to be used as reception or room telephones.

---

**Note:**

It is not possible to use the COMfortel 1100 system telephone as a reception telephone.

It is not possible to use the system telephone as a waiting field reception and as a reception telephone at the same time.

For operation on the PBXs COMpact 4406 DSL and COMpact 4410 USB, a max. of 1 hotel reception telephone is possible. For operation on the PBX COMmander Basic, a max. of 4 hotel reception telephones is possible.

---

- Use the configuration manager or the configuration software on the PBX to configure the print function.
- On each hotel reception telephone, assign a hotel room key each for each hotel room telephone to be managed.

---

**Note:**

If a check-in or check-out operation is in progress, the hotel reception telephone is not accessible for incoming calls during this period of time. It is recommended to configure call forwarding on busy for cases like this.

Note that the option of entering internal calls into the caller list must be activated if the hotel reception telephone should inform hotel guests of why their calls could not go through.

---

- Assign a hotel room key on each room telephone for call charge queries and for setting up wake-up times.

---

**Note:** In order to avoid misunderstandings when querying call charges, the value configured in COMfortel Set for the cost per call unit must correspond with the value configured in the PBX.

---

---

## Check/Change Room Status on Hotel Reception Telephone

When the guest arrives, you can check the room status and, if necessary, change it before check-in (cleaned, unclean, blocked). If the room is block, check-in is not possible. The other two states are for information only.

The checking/changing procedure can be carried out as follows:

- Via the telephone menu

### *Requirements:*

- Knowledge of the telephone, its menu options and the required PIN, if necessary
- A function key configured for hotel rooms

1. Press a **function key** configured for a hotel room twice.

---

**Note:** If the room data is being accessed by another hotel reception telephone or even by the hotel room telephone itself, you will be notified that the data is already in process.

---

2. Select **room status**.

The ● icon indicates the current setting.

3. Select the desired option:

**clean:** Indicates that the room is cleaned.

**unclean:** Indicates that the room is uncleaned.

**blocked:** Indicates that the room is out of service.

---

**Note:** After check-in, the room status is reset to **unclean** every day at midnight.

---

---

## Performing Check-in on Hotel Reception Telephone

Performing this procedure can be carried out as follows:

- Via the telephone menu

### *Requirements:*

- Knowledge of the telephone, its menu options and the required PIN, if necessary
- A function key configured for hotel rooms
- Room status not blocked

1. Press a **function key** configured for a hotel room twice.

---

**Note:** If the room data is being accessed by another hotel reception telephone or even by the hotel room telephone itself, you will be notified that the data is already in process.

---

2. Select **check in**.

---

## Configuring Wake-up Time for Room on Hotel Reception Telephone

The configuration can be carried out as follows:

- Via the telephone menu

### *Requirements:*

- Knowledge of the telephone, its menu options and the required PIN, if necessary
- A function key configured for hotel rooms
- Successful check-in

1. Press a **function key** configured for a hotel room twice.

---

**Note:** If the room data is being accessed by another hotel reception telephone or even by the hotel room telephone itself, you will be notified that the data is already in process.

---

2. Select **wake-up time**.

The ● icon indicates the current setting.

3. Select the desired option:

**switched off:** Disables wake-up. (No other action is required.)

**wake-up once:** Switches the wake-up time on for a single wake-up.

**wake-up daily:** Switches the wake-up time on for daily wake-up.

4. Enter the time.

5. Press the ✓ **softkey** to save the entry.

---

## Querying Call Charges for Room on Hotel Reception Telephone

The query can be carried out as follows:

- Via the telephone menu

### *Requirements:*

- Knowledge of the telephone, its menu options and the required PIN, if necessary
- A function key configured for hotel rooms
- Successful check-in

1. Press a **function key** configured for a hotel room twice.

---

**Note:** If the room data is being accessed by another hotel reception telephone or even by the hotel room telephone itself, you will be notified that the data is already in process.

---

2. Select **call charges**.

The call charges including check-in date are displayed.



---

## Printing Interim Invoice for Room from Hotel Reception Telephone

If the guest would like to see a breakdown of his call charges so far during his stay, you can print out an interim invoice directly from the printer. The format of the interim invoice corresponds to the final invoice, except that the check-out time is replaced by the print date. The printed data is retained in its entirety and is printed again at check-out.

The printout can be made as follows:

- Via the telephone menu

### *Requirements:*

- *Knowledge of the telephone, its menu options and the required PIN, if necessary*
- *A function key configured for hotel rooms*
- *Successful check-in*
- *Printer connected*
- *Existing call charges*

1. Press a **function key** configured for a hotel room twice.

---

**Note:** If the room data is being accessed by another hotel reception telephone or even by the hotel room telephone itself, you will be notified that the data is already in process.

---

2. Select **interim invoice**.

The call charges accumulated so far are printed.

3. Press the **✓ softkey** to accept a printout.

---

**Note:** The number of copies configured via the configuration manager on the PBX is not taken into account; this is only information for the guest. If a copy should be printed anyway, when the question appears whether the printout is ok, simply press the **✗ softkey** and then select **repeat print-out**.

---

---

## Blocking External Telephoning for Room on Hotel Reception Telephone

For example, if a guest, who has children staying in his room, wishes to restrict external calls, these calls can be blocked by the hotel reception telephone. This means that only internal calls can be made. External calls can still be accepted.

The blocking can be done as follows:

- Via the telephone menu

### *Requirements:*

- Knowledge of the telephone, its menu options and the required PIN, if necessary
- A function key configured for hotel rooms
- Successful check-in

1. Press a **function key** configured for a hotel room twice.

---

**Note:** If the room data is being accessed by another hotel reception telephone or even by the hotel room telephone itself, you will be notified that the data is already in process.

---

2. Select **external access**.

The ● icon indicates the current setting.

3. Select the desired option:

**allowed:** Allows both incoming and also fee-based outgoing external calls on the hotel room telephone.

**inbound only:** Allows only the acceptance of incoming external calls on the hotel room telephone.

---

## Performing Check-out on Hotel Reception Telephone

When checkout is performed, it is also possible to print out a final invoice. The printout contains an itemised list of calls made between the times the guest checked in and when he checked out. The invoice total corresponds with the call charge counter displayed by selecting **call charges**.

Performing this procedure can be carried out as follows:

- Via the telephone menu

*Requirements:*

- Knowledge of the telephone, its menu options and the required PIN, if necessary
- A function key configured for hotel rooms
- Successful Check-in

1. Press a **function key** configured for a hotel room twice.

---

**Note:** If the room data is being accessed by another hotel reception telephone or even by the hotel room telephone itself, you will be notified that the data is already in process.

---

2. Select **check out**.

If no call charges have accumulated, check-out is completed.

If call charges have accumulated and the printer is connected, you are asked whether you would like a printout of the final invoice.

3. Press the **✓ softkey** to initiate a printout.

The call charges accumulated during the stay are printed.

---

**Note:** If you press the **✗ softkey** instead, check-out is completed at the end.

---

4. Press the **✓ softkey** to accept the printout and to complete the check-out procedure.

---

**Note:** If the printout is not correct, press the **✗ softkey** and then select **repeat print-out**.

---

After completing check-out, all of the room data including telephone book, caller, call and redial lists as well as the volume of the ringer is reset. Any scheduled calls configured, the call charge counter and also any call data is deleted.

---

**Note:**

The PBX has a call data memory in which call data sets are saved and protected from power outages. If the capacity of the memory has been exceeded and has been overwritten by, for instance, calls made by a long-term guest, a note is made on the invoice that the itemised call list is not

complete. The total of the call charges indicated on the invoice is taken from the call charge counter which keeps track of the charge independent of the call data.

If the recording of data associated with a particular type of call is disabled in order to save called data recording space, these calls are missing from the itemised list of individual calls on the telephone invoice. The total of the call charges indicated on the invoice is taken from the call charge counter which keeps track of the charges independent of the call data.

Later, the invoice number is listed in the call data list under the project number. This number is automatically assigned during check-in.

---

### **Cancelling a Check-out or Print Job**

The cancelling procedure can be carried out as follows:

- Via the telephone menu

#### *Requirements:*

– *Knowledge of the telephone, its menu options and the required PIN, if necessary*

If you have accidentally selected the **check out** procedure or problems with the printer are preventing a correct printout, there are several options for cancelling the operation.

- Press the **Exit key**. The operation is cancelled and the room remains in the check-in state.
- When the question **print-out OK?** appears, press the **X softkey** and select **cancel print-out**. The operation is cancelled and the room remains in the check-in state.
- Do not press any key when the question **print-out OK?** appears. After three minutes, the operation is cancelled and the room remains in the check-in state.

## Configuring Wake-up Time on Hotel Room Telephone

The configuration can be carried out as follows:

- Via the telephone menu

### *Requirements:*

- A function key configured for hotel rooms
- Successful check-in

1. Press a **function key** configured for hotel rooms.
2. Select **wake-up time**.  
The ● icon indicates the current setting.
3. Select the desired option:
  - switched off**: Disables wake-up. (No other action is required.)
  - wake-up once**: Switches the wake-up time on for a single wake-up.
  - wake-up daily**: Switches the wake-up time on for daily wake-up.
4. Enter the time.
5. Press the ✓ **softkey** to save the entry.

---

## Querying Call Charges on Hotel Room Telephone

The query can be carried out as follows:

- Via the telephone menu

### *Requirements:*

- A function key configured for hotel rooms
- Successful check-in

1. Press a **function key** configured for hotel rooms.
2. Select **call charges**.  
The call charges including check-in date are displayed.

---

## Configuring and Operating Function Key for Hotel Room on Hotel Reception Telephone

Press the key twice (or use the shift key for the second level) when the telephone is in the idle state to open the menu for check-in/check-out for the hotel room telephone assigned to the key. After this is done, any functions available are dependent on the state of the room whether checked in or checked out.

Press the key once while the telephone is in the idle state to transfer the telephone number saved in the key to dial preparation – also as an additional number.

Exception: If the phone number is currently being called, pick-up the call.

After picking up the receiver, press the key to dial the telephone number saved in the key.

Press the key during a call to put the active communication partner on hold and to dial the phone number saved in the key.

In addition, the corresponding LED indicates the status of the room telephone.

### LED signalling next to the key:

Red (blinking) The room telephone is now being called. Press the key to initiate a pick-up.

Red A call is in progress on the room telephone.

Green A call was made from the room telephone and the call was not accepted.  
(blinking)

Off The room telephone is available. Press the key to place a call.

The configuration can be carried out as follows:

- Via COMfortel Set
- Via the telephone menu

## Configuring Function Key for Hotel Room on Hotel Reception Telephone via COMfortel Set

### *Requirements:*

- An open configuration and the required PIN, if necessary
- The hotel subscriber activated in the PBX (for a fee) and the hotel reception telephone function assigned to the telephone

1. Open the page **Function keys > Assign function keys**.

2. Only available in installed extension modules: In the telephone displayed at the top left, click the key group in which you would like to define keys.
3. Click the **Level 1** tab.

---

**Important:** Configuring this function is only possible on the first level. The second level is then blocked. If a function has been assigned to the second level, it is deleted.

---

4. Right-click the function key you want to assign.  
A function selection dialogue opens.
5. Select the **Hotel room** function.  
The current settings for defining the key are displayed.
6. In the **Telephone no** entry field, enter the internal telephone number for the room telephone.
7. In the **Key name** entry field, enter a name for the key. The following entries are possible:
  - Up to 16 digits
  - Digits and characters

Clicking  automatically enters the default name in the entry field.

---

**Note:** The key name is used for printing the label.

---

*Further steps:*

- *Save your configuration before closing.*

### **Configuring Function Key for Hotel Room on Hotel Reception Telephone via Telephone Menu**

*Requirements:*

- *Knowledge of the telephone, its menu options and the required PIN, if necessary*
- *The hotel subscriber activated in the PBX (for a fee) and the hotel reception telephone function assigned to the telephone*



1. Press the **menu key** and open the **define keys** menu.
2. Press the **function key** that you would like to define.
3. Select **first level**.

---

**Important:** Configuring this function is only possible on the first level. The second level is then blocked. If a function has been assigned to the second level, it is deleted.

---

The list of available functions is displayed.

4. Select the **hotel room** function.  
The current settings for defining the key are shown on the display.
5. Press the  **softkey**.
6. Select the room telephone using its name/number.
7. Press the  **softkey**.
8. Enter a new name for the room telephone. The following entries are possible:
  - Up to 16 digits
  - Digits and characters
9. Press the  **softkey** to accept the setting.

---

## Configuring and Operating Function Key for Hotel Room on Hotel Room Telephone

---

**Important:** Configuring a function key on the room telephone must be done via COMfortel Set, since configuration via the telephone menu is blocked.

---

Press the key to open the menu for querying call charges and setting up a wake-up time.

### LED signalling next to the key:

None



The configuration can be carried out as follows:

- Via COMfortel Set
- Via the telephone menu

### **Configuring Function Key for Hotel Room on Room Telephone via COMfortel Set**

*Requirements:*

- An open configuration and the required PIN, if necessary
- The hotel subscriber activated in the PBX (for a fee) and the room telephone function assigned to the telephone

1. Open the page **Function keys > Assign function keys**.
2. Only available in installed extension modules: In the telephone displayed at the top left, click the key group in which you would like to define keys.
3. Click the **Level 1** tab.

---

**Important:** Configuring this function is only possible on the first level. The second level is then blocked. If a function has been assigned to the second level, it is deleted.

---

4. Right-click the function key you want to assign.  
A function selection dialogue opens.
5. Select the **Hotel room** function.  
The current settings for defining the key are displayed.
6. In the **Telephone no** entry field, enter the internal telephone number for the room telephone.
7. In the **Key name** entry field, enter a name for the key. The following entries are possible:
  - Up to 16 digits
  - Digits and characters

Clicking  automatically enters the default name in the entry field.

## Configuring and Operating Functions

Hotel Function

Configuring and Operating Function Key for Hotel Room on Hotel Room Telephone

---

**Note:** The key name is used for printing the label.

---

### *Further steps:*

- *Save your configuration before closing.*

## InterCom Announcement/Handsfree

The InterCom function enables an announcement to one system telephone or to all system telephones of a group from any internal telephone without someone having to actively receive a call (for example, in a doctor's office).

If the InterCom destination is one system telephone, this can be programmed to switch on the microphone in addition to the loudspeaker (handsfree) so that a person nearby can speak with the caller using this intercom system.

---

### InterCom Announcement Procedure

InterCom announcement is carried out as follows:

- Depending on the InterCom destination, one system telephone or all system of a group are called using the InterCom function.

---

**Note:** Only the system telephones of the group which are ready for calls (e.g., not busy) are called. The individual group members need not to be logged into the group. They are also called when they are logged out of the group.

---

- After a few rings, either one system telephone or all system telephones of the group automatically pick up the call, depending on the InterCom destination.
- Announcement is executed.

---

**Note:** Announcement is limited to 120 seconds due to security reasons in order to prevent possible misuse of this function (for example, eavesdropping from remote rooms).

---

- After 120 seconds has elapsed, the connection is automatically interrupted. The connection can be maintained if the InterCom destination is one system telephone and the receiver is picked up before 120 seconds has elapsed.

## Executing InterCom Announcement

*Requirements:*

- Existing InterCom authorisation at the InterCom destination/s
- Configured function key for InterCom announcement

---

**Note:** InterCom announcement can also be executed from any internal telephone (see the PBX manual).

---

Depending on the kind of action configured on the key, proceed as described.

1. Press the **function key** for InterCom announcement or press and hold the **function key**.  
The LED next to the function key lights up in yellow or green to indicate the existing call connection.
2. To end announcement function, press the **function key** again or release the **function key**.

---

## Configuring and Operating Function Key for InterCom Announcement

Press the key while the telephone is in the idle state to dial the subscriber or group telephone number assigned to the key and initiate the InterCom announcement. Depending on the kind of action configured, you need to hold the key during the announcement (as soon as you release the key again, the connection is terminated) or switch the key over by briefly pressing the key (the key is pressed once at the start and once at the end).

In addition, when InterCom destination is defined on the first key level, the status of the InterCom destination connection is indicated by the corresponding LED.

**LED signalling next to the key (when defined with an internal subscriber telephone number):**

- |       |  |
|-------|--|
| Green | There is currently an active connection to the InterCom destination. |
| Off   | There is currently no active connection to the InterCom destination. |

**LED signalling next to the key (when defined with an internal group telephone number):**

- |                      |   |
|----------------------|---|
| Green                | There is currently an active connection to all InterCom destinations.         |
| Yellow               | There is currently an active connection to at least one InterCom destination. |
| Yellow<br>(blinking) | The InterCom call is sent to the PBX.   |
| Red                  | No InterCom destination can be reached.                                       |

The configuration can be carried out as follows:

- Via COMfortel Set
- Via the telephone menu

**Configuring Function Key for InterCom Announcement via COMfortel Set**

*Requirements:*

- An open configuration and the required PIN, if necessary
- For a group as InterCom destination: at least one group configured in the PBX

1. Open the page **Function keys > Assign function keys**.
2. Only available in installed extension modules: In the telephone displayed at the top left, click the key group in which you would like to define keys.
3. Click one of the following tabs:
  - Level 1:** Keys are defined on the first key level.
  - Level 2:** Keys are defined on the second key level.
4. Right-click the function key you want to assign.  
A function selection dialogue opens.

5. Select the **InterCom announcement** function.

The current settings for defining the key are displayed.

6. In the **Telephone no** entry field, enter the destination number. The following entries are possible:

**Internal telephone number of the subscriber**

**Internal telephone number of the group**

7. In the **Type** list field, select one of the following options:

**Subscriber:** Defines the telephone number entered as a subscriber telephone number.

**Group:** Defines the telephone number entered as a group telephone number.

8. In the **Kind of action** list field, select one of the following options:

**hold:** The key must be held down during the announcement.

**switch over:** A short press of the key starts the announcement. Another short press of the key ends the announcement.

9. In the **Key name** entry field, enter a name for the key. The following entries are possible:

Up to 16 digits

Digits and characters

Clicking  automatically enters the default name in the entry field.

---

**Note:** The key name is used for printing the label and for display.

---

*Further steps:*

- *Save your configuration before closing.*







*Requirements for operating the function:*

- *Existing InterCom authorisation at the InterCom destination*

## **Configuring Function Key for InterCom Announcement via Telephone Menu**

### *Requirements:*

- Knowledge of the telephone, its menu options and the required PIN, if necessary
- Existing InterCom authorisation at the InterCom destination
- For a group as InterCom destination: at least one group configured in the PBX

1. Press the **menu key** and open the **define keys** menu.
2. Press the **function key** that you would like to define.
3. Select the desired option:
  - first level:** Keys are defined on the first key level.
  - second level:** Keys are defined on the second key level.The list of available functions is displayed.
4. Select the **InterCom** function and then **InterCom OneWay**.  
The current settings for defining the key are shown on the display.
5. Scroll to the last  **softkey** to select the type of InterCom destination. Pressing the  **softkey** allows you to switch over between the different types of InterCom destinations available.
  - user:** Selects an internal subscriber as InterCom destination.
  - group:** Selects a group as InterCom destination.
6. Press the  **softkey**.
7. Select InterCom destination from the list.
8. Press the  **softkey**.
9. Enter a name. The following entries are possible:
  - Up to 16 digits
  - Digits and characters
10. Select the kind of action. Pressing the penultimate  **softkey** allows you to switch over between the different kinds of action available.
  - hold key:** The key must be held down during the announcement.
  - toggle key:** A short press of the key starts the announcement. Another short press of the key ends the announcement.
11. Press the  **softkey** to accept the setting.

## InterCom Handsfree Procedure

InterCom handsfree is carried out as follows:

- A system telephone is called using InterCom handsfree.
- After a few rings, the system telephone automatically picks up the call.
- Hands-free calling is executed.

---

**Note:** Hands-free calling is limited to 120 seconds due to security reasons in order to prevent possible misuse of this function (for example, eavesdropping from remote rooms).

---

- After 120 seconds has elapsed, the connection is automatically interrupted unless the system telephone receiver is picked up during this time.

---

## Executing InterCom Handsfree

*Requirements:*

- Existing InterCom authorisation at the InterCom destination
- Configured function key for InterCom handsfree

---

**Note:** InterCom handsfree can also be executed from any internal telephone (see the PBX manual).

---

Depending on the kind of action configured on the key, proceed as described.

1. Press the **function key** for InterCom handsfree or press and hold the **function key**.  
The LED next to the function key lights up in green to indicate the existing call connection.
2. To end handsfree function, press the **function key** again or release the **function key**.



---

## Configuring and Operating Function Key for InterCom Handsfree

Press the key while the telephone is in the idle state to dial the phone number assigned to the key and initiate InterCom handsfree. Depending on the kind of action configured, you need to hold the key during handsfree operation (as soon as you release the key again, the connection is terminated) or switch the key over by briefly pressing the key (the key is pressed once at the start and once at the end).

In addition, when InterCom destination is defined on the first key level, the status of the InterCom destination connection is indicated by the corresponding LED.

### LED signalling next to the key:

Green	There is currently an active connection to the InterCom destination.
Off	There is currently no active connection to the InterCom destination.

The configuration can be carried out as follows:

- Via COMfortel Set
- Via the telephone menu

### Configuring Function Key for InterCom Handsfree via COMfortel Set

#### *Requirements:*

– An open configuration and the required PIN, if necessary

1. Open the page **Function keys > Assign function keys**.
2. Only available in installed extension modules: In the telephone displayed at the top left, click the key group in which you would like to define keys.
3. Click one of the following tabs:
  - Level 1:** Keys are defined on the first key level.
  - Level 2:** Keys are defined on the second key level.
4. Right-click the function key you want to assign.  
A function selection dialogue opens.
5. Select the **InterCom handsfree** function.  
The current settings for defining the key are displayed.

6. In the **Telephone no** entry field, enter the destination number.
7. In the **Kind of action** list field, select one of the following options:
  - hold**: The key must be held down during the announcement.
  - switch over**: A short press of the key starts the announcement. Another short press of the key ends the announcement.
8. In the **Key name** entry field, enter a name for the key. The following entries are possible:
  - Up to 16 digits
  - Digits and characters

Clicking  automatically enters the default name in the entry field.

---

**Note:** The key name is used for printing the label and for display.

---

*Further steps:*

- *Save your configuration before closing.*

*Requirements for operating the function:*

- *Existing InterCom authorisation at the InterCom destination*





### **Configuring Function Key for InterCom Handsfree via Telephone Menu**

*Requirements:*

- *Knowledge of the telephone, its menu options and the required PIN, if necessary*
- *Existing InterCom authorisation at the InterCom destination*

1. Press the **menu key** and open the **define keys** menu.
2. Press the **function key** that you would like to define.
3. Select the desired option:
  - first level**: Keys are defined on the first key level.
  - second level**: Keys are defined on the second key level.

The list of available functions is displayed.

4. Select the **InterCom** function and then **IC speakerphone**.  
The current settings for defining the key are shown on the display.
5. Press the  **softkey**.
6. Select the InterCom destination from the list.
7. Press the  **softkey**.
8. Enter a name. The following entries are possible:
  - Up to 16 digits
  - Digits and characters
9. Select the kind of action. Pressing the  **softkey** allows you to switch over between the different kinds of action available.
  - hold key:** The key must be held down during the announcement.
  - toggle key:** A short press of the key starts the announcement. Another short press of the key ends the announcement.
10. Press the  **softkey** to accept the setting.

---

## Switching InterCom Permission On/Off

Switching this on/off can be done as follows:

- Via the telephone menu

### *Requirements:*

- Knowledge of the telephone, its menu options and the required PIN, if necessary
- Authorisation in the PBX for **Controlling of the PBX via telephone**

For InterCom calls, InterCom permission must be enabled for the system telephone being called.

Press the **function key** configured for InterCom permission to switch InterCom permission on or off.

Or, proceed as described in the following.

1. Press the **menu key** and open the menu **functions > InterCom (Auth)**.

The ● icon indicates the current setting.

2. Select the desired option:

**switch on:** Enables InterCom permission.

**switch off:** Disables InterCom permission.

---

## Configuring and Operating Function Key for InterCom Permission

Press the key to switch the InterCom permission function on or off or to switch it over.

In addition, when functions are defined on the first key level, the status of the function is indicated by the corresponding LED.

### LED signalling next to the key:

Green            InterCom permission is enabled.

Off              InterCom permission is disabled.

The configuration can be carried out as follows:

- Via COMfortel Set
- Via the telephone menu

### Configuring Function Key for InterCom Permission via COMfortel Set

*Requirements:*

– An open configuration and the required PIN, if necessary

1. Open the page **Function keys > Assign function keys**.
2. Only available in installed extension modules: In the telephone displayed at the top left, click the key group in which you would like to define keys.
3. Click one of the following tabs:
  - Level 1:** Keys are defined on the first key level.
  - Level 2:** Keys are defined on the second key level.

4. Right-click the function key you want to assign.  
A function selection dialogue opens.
5. Select the **InterCom permission** function.  
The current settings for defining the key are displayed.
6. In the **Kind of switching** list field, select one of the following options:
  - switch off**: Pressing the key disables InterCom permission.
  - switch on**: Pressing the key enables InterCom permission.
  - switch over**: Pressing the key switches InterCom permission over.
7. In the **Key name** entry field, enter a name for the key. The following entries are possible:
  - Up to 16 digits
  - Digits and characters

Clicking  automatically enters the default name in the entry field.

---

**Note:** The key name is used for printing the label.

---

*Further steps:*

- *Save your configuration before closing.*

*Requirements for operating the function:*

- *Authorisation in the PBX for **Controlling of the PBX via telephone***

### **Configuring Function Key for InterCom Permission via Telephone Menu**

*Requirements:*

- *Knowledge of the telephone, its menu options and the required PIN, if necessary*

1. Press the **menu key** and open the **define keys** menu.
2. Press the **function key** that you would like to define.

3. Select the desired option:

**first level:** Keys are defined on the first key level.

**second level:** Keys are defined on the second key level.

The list of available functions is displayed.

4. Select the **InterCom (Auth)** function.

The current settings for defining the key are shown on the display.

5. Select the kind of switching. Pressing the  **softkey** allows you to switch over between the different kinds of switching.

**switch off:** Pressing the key disables InterCom permission.

**switch on:** Pressing the key enables InterCom permission.

**switch over:** Pressing the key switches InterCom permission over.

6. Press the  **softkey** to accept the setting.

*Requirements for operating the function:*

– *Authorisation in the PBX for **Controlling of the PBX via telephone***

## Loudspeaker Audio Out

This function enables loudspeaker audio out over an audio output on the loudspeaker connected to the PBX unit or an active loudspeaker (for example, a loudspeaker system in a department store/supermarket). In addition, a previously specified telephone number is called by an internal telephone. The call connection is immediately established after dialling the telephone number.

---

### Executing Loudspeaker Audio Out

---

**Important:** Not available for operation on the PBX COMpact 3000.

---

The execution can be made as follows:

- Via the telephone menu

*Requirements:*

- Authorization in the PBX for **Speaker announcement**
- A function key configured for loudspeaker audio out

---

**Note:** Loudspeaker audio out can also be executed from any internal telephone (see PBX manual).

---

Depending on the kind of action configured on the key, proceed as described.

1. Press the **function key** for InterCom announcement/handsfree or press and hold the **function key**.  
The LED next to the function key lights up in green to indicate the existing call connection.
2. To end announcement or handsfree function, press the **function key** again or release the **function key**.

---

## Configuring and Operating Function Key for Loudspeaker Audio Out

---

**Important:** Not available for operation on the PBX COMpact 3000.

---

Press the key while the telephone is in the idle state to establish a connection to the audio output on the PBX. Depending on the kind of action configured, you need to hold the key during the audio out (as soon as you release the key again, the connection is terminated) or switch the key over by briefly pressing the key (the key is pressed once at the start and once at the end).

In addition, when the audio output is defined on the first key level, the status of the audio output connection is indicated by the corresponding LED.

### LED signalling next to the key:

Green	There is currently an active connection to the audio output.
Off	There is currently no active connection to the audio output.

The configuration can be carried out as follows:

- Via COMfortel Set
- Via the telephone menu

### Configuring Function Key for Loudspeaker Audio Out via COMfortel Set

#### *Requirements:*

- An open configuration and the required PIN, if necessary
- An audio output configured in the PBX

1. Open the page **Function keys > Assign function keys**.
2. Only available in installed extension modules: In the telephone displayed at the top left, click the key group in which you would like to define keys.
3. Click one of the following tabs:
  - Level 1:** Keys are defined on the first key level.
  - Level 2:** Keys are defined on the second key level.
4. Right-click the function key you want to assign.  
A function selection dialogue opens.



5. Select the **InterCom audio out** function.

The current settings for defining the key are displayed.

6. In the **Telephone no** entry field, enter the internal telephone number for the audio output.
7. In the **Kind of action** list field, select one of the following options:
  - hold**: The key must be held down during the announcement.
  - switch over**: A short press of the key starts the announcement. Another short press of the key ends the announcement.
8. In the **Key name** entry field, enter a name for the key. The following entries are possible:

Up to 16 digits

Digits and characters

Clicking  automatically enters the default name in the entry field.

---

**Note:** The key name is used for printing the label and for display.

---

*Further steps:*

- *Save your configuration before closing.*

*Requirements for operating the function:*

- *Authorization in the PBX for **Speaker announcement***

### **Configuring Function Key for Loudspeaker Audio Out via Telephone Menu**

*Requirements:*

- *Knowledge of the telephone, its menu options and the required PIN, if necessary*
- *An audio output configured in the PBX*

1. Press the **menu key** and open the **define keys** menu.
2. Press the **function key** that you would like to define.

3. Select the desired option:

**first level:** Keys are defined on the first key level.

**second level:** Keys are defined on the second key level.

The list of available functions is displayed.

4. Select the **InterCom** function and then **Audio out**.

The current settings for defining the key are shown on the display.

5. Select the kind of switching. Pressing the  **softkey** allows you to switch over between the different kinds of switching.

**hold key:** The key must be held down during audio out.

**toggle key:** A short press of the key starts audio out. Another short press of the key ends audio out.

6. Press the  **softkey** to accept the setting.

*Requirements for operating the function:*

– *Authorization in the PBX for **Speaker announcement***

# Macro

The macro function enables a function key to be defined with digits and various consecutive commands, for example, for accessing an answering machine remotely or programming a function on the PBX.

---

## Macro Execution Procedure

The following describes the procedure based on an example key using the following command sequence **HZ300CW2Z#22#Lg**:

- Command **H**: After pressing the macro key, the telephone switches to hands-free calling.

---

**Note:** If the **H** command (hang-up/pick-up with the hook key) is located at the beginning of the macro, the start of macro execution must be confirmed.

---

- Command **Z300**: The telephone dials the phone number 300 (for example, the answering machine).
- Command **C**: The telephone waits for the connection.
- Command **W2**: After the connection has been established, the telephone waits another 2 seconds.
- Command **Z#22#**: The telephone dials the DTMF code #22#.
- Command **Lg**: The LED next to the function key switches on (green).

---

**Important:** The state of the LED remains the same after a macro is executed – until the next time the command Lo, Lg, Lr or Ly is executed with the same key. If the LED is not to be used for status indication, it is recommended that you add the command Lo (disable LED) to the end of a macro.

If you would like to end macro execution, press the **Exit key**.

Macro execution is ended immediately when an incoming call is made to a destination that is busy or when a connection returns that it is busy. This occurs, for instance, when the other calling party ends the call or the macro contains a programming code that is not authorised.

---

## Configuring and Operating Function Key for Macro

Press the key while the telephone is in the idle state to execute a macro. If the H command (hang-up/pick-up with the hook key) is located at the beginning of a macro, the macro saved in the system is executed immediately. If this is not the case, you need to first confirm the start of macro execution.

In addition and depending on the settings, when a macro is defined on the first key level, the status of the macro in question is indicated by the corresponding LED.

### LED signalling next to the key:

Depending on the purpose of the commands Lo, Lg, Lr and Ly.

---

**Note:** If there is a macro on both levels of a function key, LED control is also performed by the macro on the second level. This makes it possible, for instance, to use the macro to switch the LED on the one key level and to use the macro to switch LED off on the other key level. This allows the switching status of a simultaneously switched function to be read on the LED.

---

The configuration can be carried out as follows:

- Via COMfortel Set
- Via the telephone menu

### Configuring Function Key for Macro via COMfortel Set

*Requirements:*

– An open configuration and the required PIN, if necessary

1. Open the page **Function keys > Assign function keys**.
2. Only available in installed extension modules: In the telephone displayed at the top left, click the key group in which you would like to define keys.
3. Click one of the following tabs:
  - Level 1:** Keys are defined on the first key level.
  - Level 2:** Keys are defined on the second key level.
4. Right-click the function key you want to assign.

A function selection dialogue opens.

5. Select the **Macro** function.

The current settings for defining the key are displayed.

6. In the **Macro sign** entry field, enter the macro. The following entries are possible:

Up to 100 characters for a max. of 10 keys, up to 40 characters for additional keys

The commands listed at the end:

**Z [digit sequence]:** Digit sequence selection including \* and #

**W [digits 1-5]:** Waiting time/pause time of 1-5 seconds

**K:** Switchover to keypad

**M:** Switchover to DTMF

**H:** Hang-up/pick-up with the hook key

**C:** Wait for a connection

**Lo:** The LED next to the function key switches off

**Lr:** The LED next to the function key switches on (red)

**Ly:** The LED next to the function key switches on (yellow)

**Lg:** The LED next to the function key switches on (green)

---

**Note:**

If you would like to configure a programming function on the PBX as a macro, enter a pause between the password and programming code sequence.

Pauses cannot be entered at the beginning of a macro.

The maximum pause time is 5 seconds. This restriction does not apply for the C command (waiting for a connection).

LED control commands are only possible on the first level. Exception: If there is a macro on both levels of a function key, LED control is also performed by the macro on the second level. This makes it possible, for instance, to use the macro to switch the LED on on the one key level and to use the macro to switch LED off on the other key level. This allows the switching status of a simultaneously switched function to be read on the LED.

---

7. In the **Key name** entry field, enter a name for the key. The following entries are possible:

Up to 16 digits  
Digits and characters

Clicking  automatically enters the default name in the entry field.

---

**Note:** The key name is used for printing the label and for display.

---

*Further steps:*

- *Save your configuration before closing.*

### Configuring Function Key for a Macro via Telephone Menu

*Requirements:*

- *Knowledge of the telephone, its menu options and the required PIN, if necessary*

1. Press the **menu key** and open the **define keys** menu.
2. Press the **function key** that you would like to define.
3. Select the desired option:

**first level:** Keys are defined on the first key level.

**second level:** Keys are defined on the second key level.

The list of available functions is displayed.

4. Select the **macro** function.

The current settings for defining the key are shown on the display.

5. Press the  **softkey**.

6. Enter a name. The following entries are possible:

Up to 16 digits  
Digits and characters

7. Press the **▶|| softkey**.

8. Enter the macro. The following entries are possible:

Up to 100 characters for a max. of 10 keys, up to 40 characters for additional keys

The commands listed at the end:

**Z [digit sequence]:** Digit sequence selection including \* and #

**W [digits 1-5]:** Waiting time/pause time of 1-5 seconds

**K:** Switchover to keypad

**M:** Switchover to DTMF

**H:** Hang-up/pick-up with the hook key

**C:** Wait for a connection

**Lo:** The LED next to the function key switches off

**Lr:** The LED next to the function key switches on (red)

**Ly:** The LED next to the function key switches on (yellow)

**Lg:** The LED next to the function key switches on (green)

---

**Note:**

If you would like to configure a programming function on the PBX as a macro, enter a pause between the password and programming code sequence.

Pauses cannot be entered at the beginning of a macro.

The maximum pause time is 5 seconds. This restriction does not apply for the C command (waiting for a connection).

---

9. Press the  **softkey** to accept the setting.

---

## Configuring Display Presentation during Macro Execution

This setting specifies if the digits that have just been dialled or the name of the key are shown in the telephone display during macro execution.

The configuration can be made as follows:

- Via COMfortel Set
- Via the telephone menu

## **Configuring Display Presentation during Macro Execution via COMfortel Set**

### *Requirements:*

- *An open configuration and the required PIN, if necessary*

1. Open the page **Settings/functions > User settings**.
2. Under **Display presentation during macro execution**, select one of the following options:

**Single steps:** During macro execution, the digits that have just been dialled are shown.

**Name of the key/name of the contact:** During macro execution, the name of the key is shown on the display.

### *Further steps:*

- *Save your configuration before closing.*

## **Configuring Display Presentation during Macro Execution via Telephone Menu**

### *Requirements:*

- *Knowledge of the telephone, its menu options and the required PIN, if necessary*

1. Press the **menu key** and open the menu **settings > user settings > macro display**.  
The ● icon indicates the current setting.
2. Select the desired option:

**title/name:** During macro execution, the name of the key is shown on the display.

**macro steps:** During macro execution, the digits that have just been dialled are shown.



# Memo

The memo function allows you to enter a telephone number note on the telephone during a call. After the call has been ended, the telephone number can be retrieved and, for instance, accepted into dial preparation.

---

## Creating a Memo

The creation can be carried out as follows:

- Via the telephone menu

### *Requirements:*

– *Knowledge of the telephone and its menu options*

During a call, proceed as described in the following.

1. Select **memo**.
2. Press the **✓ softkey**.
3. Enter the phone number that you would like to make a note of.
4. Press the **✓ softkey** to save the entry.

## Retrieving a Memo

The retrieval can be carried out as follows:

- Via the telephone menu

### *Requirements:*

- *Knowledge of the telephone and its menu options*
- *A saved memo*

1. Press the  **softkey**.

The saved phone number is displayed.

2. Press the  **softkey** in order to accept the phone number for further use in dial preparation.

---

**Note:** If you would like to delete the phone number, instead press the  **softkey**.

---

# Phone Lock

The phone lock can be used to block the telephone from unauthorised use. Even after enabling the phone lock, it is possible to receive incoming calls and to make emergency calls (manual dialling of emergency numbers entered in the PBX only).

---

## Enabling the Phone Lock

### *Requirements:*

- Knowledge of the telephone, its menu options and the required PIN, if necessary
- Configured user or subadmin PIN

- Press the **menu key** and open the menu **functions > phone lock**.

Or, press the **function key** configured for the phone lock.

---

## Disabling the Phone Lock

The disabling procedure can be carried out as follows:

- Via the telephone menu

### *Requirements:*

- Knowledge of the telephone, its menu options and the required PIN, if necessary
- Knowledge of the user, subadmin or admin PIN

1. Press the  **softkey**.

Or, press the **function key** configured for the phone lock.

2. Enter the user, subadmin or admin PIN.

3. Press the  **softkey**.

## Configuring and Operating Function Key for Phone Lock

Press the key on the telephone in the idle state to enable the phone lock.

Press the key again and then enter the user PIN, admin PIN or subadmin PIN to disable the phone lock again.

In addition, when functions are defined on the first key level, the status of the function is indicated by the corresponding LED.

### LED signalling next to the key:

Red                The phone lock is enabled.

Off                The phone lock is disabled.

The configuration can be carried out as follows:

- Via COMfortel Set
- Via the telephone menu

## Configuring Function Key for Phone Lock via COMfortel Set

### *Requirements:*

– An open configuration and the required PIN, if necessary

1. Open the page **Function keys > Assign function keys**.
2. Only available in installed extension modules: In the telephone displayed at the top left, click the key group in which you would like to define keys.
3. Click one of the following tabs:
  - Level 1:** Keys are defined on the first key level.
  - Level 2:** Keys are defined on the second key level.
4. Right-click the function key you want to assign.  
A function selection dialogue opens.
5. Select the **Phone lock** function.  
The current settings for defining the key are displayed.

6. In the **Key name** entry field, enter a name for the key. The following entries are possible:

- Up to 16 digits
- Digits and characters

Clicking  automatically enters the default name in the entry field.

---

**Note:** The key name is used for printing the label.

---

*Further steps:*

- *Save your configuration before closing.*

*Requirements for operating the function:*

- *Configured user, subadmin or admin PIN*
- *For enabling the function: Knowledge of the user or subadmin PIN*
- *For disabling the function: Knowledge of the user, subadmin or admin PIN*

### **Configuring Function Key for Phone Lock via Telephone Menu**

*Requirements:*

- *Knowledge of the telephone, its menu options and the required PIN, if necessary*

1. Press the **menu key** and open the **define keys** menu.
2. Press the **function key** that you would like to define.
3. Select the desired option:

**first level:** Keys are defined on the first key level.

**second level:** Keys are defined on the second key level.

The list of available functions is displayed.

4. Select the **phone lock** function.  
The current settings for defining the key are shown on the display.
5. Press the  **softkey** to accept the setting.

## Configuring and Operating Functions

Phone Lock

Configuring and Operating Function Key for Phone Lock

*Requirements for operating the function:*

- Configured user, subadmin or admin PIN*
- For enabling the function: Knowledge of the user or subadmin PIN*
- For disabling the function: Knowledge of the user, subadmin or admin PIN*

# Pickup

Using Pickup, you can take a call on your own phone that was originally sent to another internal telephone.

If the call has already been taken, the call can be taken using same procedure if the call take-over has been allowed by the subscriber being called. This function is useful, for example, in the case of answering machines.

---

## Executing Pickup

*Requirements:*

- Knowledge of the telephone, its menu options and the required PIN, if necessary
- Authorization in the PBX for **Pickup**

If an internal telephone rings in your proximity, proceed as described in the following.

1. Press the **☎** **softkey** and select **pickup**.  
Or, press a **function key** configured for pickup.
2. Enter the internal phone number of the telephone that is ringing. (In case of direct exchange access you do not have to dial \*\* first.)

---

**Note:** If you would like to take call that is directed to a group, select the pickup for the group telephone number.

---

3. Pick up the receiver or press the **Hook key**.

---

## Executing Pickup during Call

*Requirements:*

- Knowledge of the telephone, its menu options and the required PIN, if necessary
- Authorization in the PBX for **Pickup**

If you are already taking a call and an internal telephone rings in your proximity, proceed as described in the following.

1. Select **pickup**.
2. Press the **✓ softkey**.  
You will hear the internal dial tone. The person you had been talking to hears the hold music.
3. Enter the internal phone number of the telephone that is ringing. (In case of direct exchange access you do not have to dial \*\* first.)

---

**Note:** If you would like to take call that is directed to a group, select the pickup for the group telephone number.

---

Once you have finished dialling the phone number, you are connected to the caller.

---

## Configuring and Operating Function Key for Pickup

Pressing the key opens the **pickup** menu. This allows you to enter the internal phone number of the telephone that is ringing.

In addition, you can press the key to initiate a call take-over on telephones or answering machines for which permission has been given (see the PBX manual).

### LED signalling next to the key:

None

---

**Note:** If you often take pickups for specific telephones, you can configure a speed dialling key for the associated internal subscriber/group telephone as an alternative to this key. You then see a red blinking LED indicating that the phone number is being called. You can press the speed dialling key and after the confirmation, take the call on your telephone.

---

The configuration can be carried out as follows:

- Via COMfortel Set
- Via the telephone menu



## **Configuring Function Key for Pick-up via COMfortel Set**

### *Requirements:*

- *An open configuration and the required PIN, if necessary*

1. Open the page **Function keys > Assign function keys**.
2. Only available in installed extension modules: In the telephone displayed at the top left, click the key group in which you would like to define keys.
3. Click one of the following tabs:
  - Level 1:** Keys are defined on the first key level.
  - Level 2:** Keys are defined on the second key level.
4. Right-click the function key you want to assign.  
A function selection dialogue opens.
5. Select the **Pick-up** function.  
The current settings for defining the key are displayed.
6. In the **Key name** entry field, enter a name for the key. The following entries are possible:
  - Up to 16 digits
  - Digits and characters

Clicking  automatically enters the default name in the entry field.

---

**Note:** The key name is used for printing the label.

---

### *Further steps:*

- *Save your configuration before closing.*

### *Requirements for operating the function:*

- *Authorization in the PBX for **Pickup***

## **Configuring Function Key for Pickup via Telephone Menu**

### *Requirements:*

– *Knowledge of the telephone, its menu options and the required PIN, if necessary*

1. Press the **menu key** and open the **define keys** menu.
2. Press the **function key** that you would like to define.
3. Select the desired option:

**first level:** Keys are defined on the first key level.

**second level:** Keys are defined on the second key level.

The list of available functions is displayed.

4. Select the **pickup** function.

The current settings for defining the key are shown on the display.

5. Press the **✓ softkey** to accept the setting.

### *Requirements for operating the function:*

– *Authorization in the PBX for **Pickup***

# Power Dialling

If the telephone being called is busy, but automatic callback on busy is not possible, the power dialling function be activated instead. When this is done, the system telephone attempts to reach the subscriber being called in short time intervals.

---

## Power Dialling Procedure

Power dialling is executed as follows:

- The system telephone attempts to reach the subscriber being called in short time intervals (every 10 seconds).
- As soon as the subscriber is no longer busy and the system telephone detects a dial tone, it switches the loudspeaker.
- The connection is then established when the person being called picks up the receiver. If he does not pick up the receiver, power dialling is ended.
- If power dialling is not successful, the system telephone automatically cancels the function after 10 minutes.

---

**Note:** If interruptions occur (for example, calls that are initiated intermittently), this time period is extended accordingly.

---

---

## Executing Power Dialling

*Requirements:*

– *Knowledge of the telephone, its menu options and the required PIN, if necessary*

---

**Note:** The power dialling function may not be used when calling a VoIP number.

---

If the connection is busy and callback is not possible, proceed as described in the following.

1. Select **Power Dialling**.
2. Press the  **softkey** in order to initiate power dialling.

---

**Note:** Avoid leaving the telephone once power dialling has been activated since whenever a connection is established, the loudspeaker on the system telephone is automatically switched on.

---

---

## Cancelling Power Dialling

### *Requirements:*

- *Power dialling has been initiated*

If you would like to cancel power dialling in progress, proceed as described in the following.

- The telephone is now in the idle state: Press the  **softkey**.
- The telephone is not in the idle state. It is currently attempting to reach the subscriber in question: Press the **Hook key**.

---

## Switching Attention Tone for Power Dialling On/Off

If the attention tone for power dialling has been enabled, the attention tone signals that the subscriber being called with power dialling is no longer busy and the loudspeaker has been switched on. The volume of the attention tone is dependent on the configured ringer volume.

Switching this on/off can be done as follows:

- Via COMfortel Set
- Via the telephone menu

### **Switching Attention Tone for Power Dialling On/Off via COMfortel Set**

*Requirements:*

– An open configuration and the required PIN, if necessary

1. Open the page **Settings/functions > Signalling/ringer**.
2. Select or clear the **Attention tone (power dialling)** check box.
  - Enables the attention tone for power dialling.
  - Disables the attention tone for power dialling.

*Further steps:*

– Save your configuration before closing.

### **Switching Attention Tone for Power Dialling On/Off via Telephone Menu**

*Requirements:*

– Knowledge of the telephone, its menu options and the required PIN, if necessary

1. Press the **menu key** and open the menu **settings > signalling > attention tone**.
2. Select or clear the **power dialling** check box.
  - Enables the attention tone for power dialling.
  - Disables the attention tone for power dialling.
3. Press the **✓ softkey** to accept the setting.

## Power Save Mode

In power save mode, the display lighting (if available) and the LEDs are inactive (exception: the message LED blinks for missed calls).

After a configurable waiting time and depending on the configuration, power save mode can be activated automatically during the switchover into a PBX configuration and/or manually by pressing a key. Power save mode is deactivated again as soon as an incoming call is signalled or any key is pressed.

---

### Switching Automatic Activation of Power Save Mode On/Off

If automatic activation of power save mode is enabled, the telephone automatically switches into power save mode when the telephone is not in use.

The holding time indicates how much time after the key was last pressed before power save mode is activated.

Switching this on/off can be done as follows:

- Via COMfortel Set
- Via the telephone menu

### Switching Automated Activation of Power Save Mode On/Off via COMfortel Set

*Requirements:*

– An open configuration and the required PIN, if necessary

1. Open the page **Settings/functions > Power save mode**.
2. Select or clear the **Automated activation** check box.
  - Enables the automated activation of power save mode.
  - Disables the automated activation of power save mode.
3. Enter a value in the corresponding **Waiting time (1 to 999 minutes)** entry field. The following entries are possible:
  - 1 to 999:** After 1 to 999 minutes, power save mode is automatically activated, depending on the entry.

*Further steps:*

- *Save your configuration before closing.*

### **Switching Automatic Activation of Power Save Mode On/Off via Telephone Menu**

*Requirements:*

- *Knowledge of the telephone, its menu options and the required PIN, if necessary*

1. Press the **menu key** and open the menu **settings > power save mode > autom.activation**.
2. Select or clear the **autom.activation** check box.
  - Enables the automated activation of power save mode.
  - Disables the automated activation of power save mode.
3. Open the menu **settings > power save mode > idle time**.
4. Enter a value. The following entries are possible:
  - 1 to 199:** After 1 to 999 minutes, power save mode is automatically activated, depending on the entry.
5. Press the **✓ softkey** to accept the setting.

---

### **Switching Power Save Mode Activation On/Off Depending on Configuration**

If configuration-dependent power save mode activation is enabled, the telephone goes into power save mode during a switchover into a specific PBX configuration (for example, a night configuration).

Switching this on/off can be done as follows:

- Via COMfortel Set
- Via the telephone menu

## **Switching Configuration-dependent Activation of Power Save Mode On/Off via COMfortel Set**

### *Requirements:*

– An open configuration and the required PIN, if necessary

1. Open the page **Settings/functions > Power save mode**.
2. Make the necessary changes depending on the type of PBX.
  - In the **Configuration** entry field, select a configuration in order to enable the configuration-dependent activation of power save mode.
  - In the **Configuration (10 to 9999)** entry field, enter the identification number of a configuration in order to enable the configuration-dependent activation of power save mode.

---

**Note:** To disable the configuration-dependent activation of power save mode, you need to select --- in the list field or delete the identification number of the configuration from the entry field.

---

### *Further steps:*

– Save your configuration before closing.

## **Switching Configuration-dependent Activation of Power Save Mode On/Off via Telephone Menu**

### *Requirements:*

– Knowledge of the telephone, its menu options and the required PIN, if necessary

1. Press the **menu key** and open the menu **settings > power save mode > configuration**.  
The ● icon indicates the current setting.
2. Select the desired option:
  - switch off:** Disables configuration-dependent activation. (No other action is required.)
  - switch on:** Enables configuration-dependent activation.
3. Select a configuration from the list.



## Configuring and Operating Function Key for Manually Activating Power Save Mode

Pressing the key while in the telephone's idle state switches it immediately into power save mode.

### LED signalling next to the key:

None

The configuration can be carried out as follows:

- Via COMfortel Set
- Via the telephone menu

### Configuring Function Key for Manually Activating Power Save Mode via COMfortel Set

#### *Requirements:*

– An open configuration and the required PIN, if necessary

1. Open the page **Function keys > Assign function keys**.
2. Only available in installed extension modules: In the telephone displayed at the top left, click the key group in which you would like to define keys.
3. Click one of the following tabs:
  - Level 1:** Keys are defined on the first key level.
  - Level 2:** Keys are defined on the second key level.
4. Right-click the function key you want to assign.  
A function selection dialogue opens.
5. Select the **Power save mode** function.  
The current settings for defining the key are displayed.
6. In the **Key name** entry field, enter a name for the key. The following entries are possible:
  - Up to 16 digits
  - Digits and characters

Clicking  automatically enters the default name in the entry field.

---

**Note:** The key name is used for printing the label.

---

*Further steps:*

- *Save your configuration before closing.*

### **Configuring Function Key for Manually Activating Power Save Mode via Telephone Menu**

*Requirements:*

- *Knowledge of the telephone, its menu options and the required PIN, if necessary*

1. Press the **menu key** and open the **define keys** menu.

2. Press the **function key** that you would like to define.

3. Select the desired option:

**first level:** Keys are defined on the first key level.

**second level:** Keys are defined on the second key level.

The list of available functions is displayed.

4. Select the **power save mode** function.

The current settings for defining the key are shown on the display.

5. Press the **✓ softkey** to accept the setting.

---

### **Switching the Power Save Mode Link to Phone Lock On/Off**

If the power save mode link to the phone lock is enabled, the phone lock is enabled as soon as the telephone changes to power save mode.

Switching this on/off can be done as follows:

- Via COMfortel Set
- Via the telephone menu

### **Switching Power Save Mode Link to Phone Lock On/Off via COMfortel Set**

*Requirements:*

– An open configuration and the required PIN, if necessary

1. Open the page **Settings/functions > Power save mode**.
2. Select or clear the **Link to telephone lock** check box.
  - Enables the power save mode link to the phone lock.
  - Disables the power save mode link to the phone lock.

*Further steps:*

– Save your configuration before closing.

### **Switching Power Save Mode Link to Phone Lock On/Off via Telephone Menu**

*Requirements:*

- Knowledge of the telephone, its menu options and the required PIN, if necessary
- Configured user, subadmin or admin PIN
- Knowledge of the user, subadmin or admin PIN

1. Press the **menu key** and open the menu **settings > power save mode > phone lock**.
2. Select or clear the **phone lock** check box.
  - Enables the power save mode link to the phone lock.
  - Disables the power save mode link to the phone lock.
3. Press the **✓ softkey** to accept the setting.

# Project Assignment

The exchange line access with project assignment enables an external call to be assigned to a specific project/customer/client (for example, in a lawyer's office). Based on the evaluation of call data, both the charges as well as the time required can be assigned to a specific project.

---

## Detailed Information about Project Assignment

---

**Important:** Not available for operation on the PBXs COMpact 2204 USB and COMpact 3000.

---

Project numbers can be used and managed in different ways:

### Direct entry

Before or during a call, you can enter any project number directly via the menu.

### Function key

You can configure one defined function key for each project. Before or during a call, you select a project by pressing one of these function keys.

### Project list

In COMfortel Set you can create a project list with up to 100 project numbers. Before or during a call, you select a project by means of the corresponding name in the project list.

---

## Initiating a Project Assignment

Initiation can be carried out as follows:

- Via the telephone menu

*Requirements:*

- Knowledge of the telephone, its menu options and the required PIN, if necessary
- Project numbers enabled in the PBX (for a fee)

In order to define a project number for the next outgoing call, press the **function key** configured for project assignment.

Or, proceed as described in the following.

1. Press the **☰ softkey** and select **project**.  
Or press the **menu key** and open the menu **functions > project**.
2. Select the desired project using its name/number or enter the project number. The following entries are possible:  
2 to 6 digits
3. Press the **✓ softkey** to save the entry.

The selected project is then assigned to the next outgoing call.

---

**Note:** If you have entered a project number for the next outgoing call and are called before starting your own call, the project number is discarded by the telephone.

---

---

## Executing Project Assignment during a Call

The execution can be made as follows:

- Via the telephone menu

*Requirements:*

- Knowledge of the telephone, its menu options and the required PIN, if necessary
- Project numbers enabled in the PBX (for a fee)

In order to assign a call in progress to a project, press the **function key** configured for project assignment.

Or, proceed as described in the following.

1. Select **project**.
2. Press the **✓ softkey**.
3. Select the desired project using its name/number or enter the project number. The following entries are possible:  
2 to 6 digits
4. Press the **✓ softkey** to save the entry.

---

## Configuring and Operating Function Key for Project Assignment

Press the key for general functions to open the menu for selecting or entering a project number.

Press the key defined for project assignment when in the idle state of the telephone to assign the next outgoing external call to the corresponding project number. After this, you can initiate the call by dialling an external phone number (with the exchange line access number).

Press the key defined for project assignment during a call to set which project number the current external call will be assigned to.

In addition, when functions are defined on the first key level, the status of the function is indicated by the corresponding LED.

### LED signalling next to the key:

- |       |   |
|-------|---|
| Green | The project number on the key is assigned to the next outgoing external call (for a key configured for general functions, it applies for any project number). |
| Off   | The next outgoing call will not be assigned to a project.   |

The configuration can be carried out as follows:

- Via COMfortel Set
- Via the telephone menu

## **Configuring Function Key for General Project Assignment via COMfortel Set**

### *Requirements:*

- *An open configuration and the required PIN, if necessary*

1. Open the page **Function keys > Assign function keys**.
2. Only available in installed extension modules: In the telephone displayed at the top left, click the key group in which you would like to define keys.
3. Click one of the following tabs:
  - Level 1:** Keys are defined on the first key level.
  - Level 2:** Keys are defined on the second key level.
4. Right-click the function key you want to assign.  
A function selection dialogue opens.
5. Select the **Project** function.  
The current settings for defining the key are displayed.
6. In the **Key name** entry field, enter a name for the key. The following entries are possible:
  - Up to 16 digits
  - Digits and characters

Clicking  automatically enters the default name in the entry field.

---

**Note:** The key name is used for printing the label.

---

### *Further steps:*

- *Save your configuration before closing.*

### *Requirements for operating the function:*

- *Project numbers enabled in the PBX (for a fee)*

## **Configuring Function Key for Project Assignment via COMfortel Set**

### *Requirements:*

- An open configuration and the required PIN, if necessary

1. Open the page **Function keys > Assign function keys**.
2. Only available in installed extension modules: In the telephone displayed at the top left, click the key group in which you would like to define keys.
3. Click one of the following tabs:
  - Level 1:** Keys are defined on the first key level.
  - Level 2:** Keys are defined on the second key level.
4. Right-click the function key you want to assign.  
A function selection dialogue opens.
5. Select the **Defined project** function.  
The current settings for defining the key are displayed.
6. In the **Project number** entry field, enter the project number of the project. The following entries are possible:

2 to 6 digits

Click  to enter a project number from the project list into the **Project number** entry field.

7. In the **Key name** entry field, enter a name for the key. The following entries are possible:

Up to 16 digits

Digits and characters

Clicking  automatically enters the default name in the entry field.

---

**Note:** The key name is used for printing the label and for display.

---

### *Further steps:*

- Save your configuration before closing.

### *Requirements for operating the function:*





- Project numbers enabled in the PBX (for a fee)



## Configuring Function Key for Project Assignment via Telephone Menu

### *Requirements:*

- Knowledge of the telephone, its menu options and the required PIN, if necessary

1. Press the **menu key** and open the **define keys** menu.
2. Press the **function key** that you would like to define.
3. Select the desired option:
  - first level:** Keys are defined on the first key level.
  - second level:** Keys are defined on the second key level.The list of available functions is displayed.
4. Select the **project** function.  
The current settings for defining the key are shown on the display.
5. Select the kind of key. Press the  **softkey** to switch over between the different kinds of keys.
  - general:** Press the key to open the menu for selecting a project. (No other action is required.)
  - defined:** Press the key to define a saved project number for the next external call.
6. Press the  **softkey**.
7. Enter a project number. The following entries are possible:
  - 2 to 6 digits
8. Press the  **softkey**.
9. Enter a name for the project number. The following entries are possible:
  - Up to 16 digits
  - Digits and characters
10. Press the  **softkey** to accept the setting.

### *Requirements for operating the function:*

- Project numbers enabled in the PBX (for a fee)

## Configuring a List for Project Assignment

If a project has been entered in the project list, it can be simply selected before or during a call. The project list can contain up to 100 project numbers with the corresponding names.

The configuration can be carried out as follows:

- Via COMfortel Set

### *Requirements:*

– *An open configuration and the required PIN, if necessary*

1. Open the **Project list** page.
2. In the **Project number** column, enter the project numbers you want. The following entries are possible:  
2 to 6 digits
3. In the **Project name** column, enter a name for the project. The following entries are possible:  
Up to 16 digits  
Digits and characters

### *Further steps:*

– *Save your configuration before closing.*

---

## Exporting a Project List

The export can be carried out as follows:

- Via COMfortel Set

### *Requirements:*

– *An open configuration and the required PIN, if necessary*  
– *Existing entries in the project list*

1. Open the **Project list** page.
2. Click **CSV-Export**.  
A dialogue for selecting the separator character opens.
3. Select the desired delimiter character to be used to separate each entry into individual columns and click **OK**.  
A dialogue for selecting the columns to be exported opens.
4. Select or clear the **Project number** check box.
  - The column **Project number** is exported.
  - The column **Project number** is not exported.
5. Select or clear the **Project name** check box.
  - The column **Project name** is exported.
  - The column **Project name** is not exported.
6. Click **OK**.  
A file location dialogue opens.
7. Select the directory in which you would like to save the file.
8. Enter a filename with the ending .csv and click **Save** (this text is dependent on the operating system used).

---

**Note:** Under **Project name**, if you use characters that could also be recognised as control characters during an export to CSV (for example, a semicolon), these characters will be accepted in the file unverified. This can lead to problems when reimporting the edited files.

---

---

## Importing a Project List

The import can be carried out as follows:

- Via COMfortel Set

*Requirements:*

- An open configuration and the required PIN, if necessary
- A project list saved on the hard drive as a file (\*.csv), data arranged in rows and columns, separated by a delimiter character (semicolon, comma, tab or your own separator)

1. Open the **Project list** page.
2. Click **CSV-Import**.  
A dialogue for selecting the separator character opens.
3. Select the delimiter character to be used to separate the entries into individual columns in the file to be imported and click **OK**.  
A dialogue for selecting the columns to be imported opens.
4. Switch in the directory where the file is located. Select the file to be imported.
5. In the **Project number** and **Project name** list fields, assign how the individual pieces of data are to be distributed in the table columns.
6. In the lower list field, select one of the following options:
  - unsynchronized:** All previous entries remain unchanged. Additional project numbers belonging to the file to be imported are accepted into the project list along with their names.
  - Synchronize after -Project number:** If the project list already contains a project number that also occurs in the file to be imported, you can decide which project name should appear in the project list.
  - Synchronize after -Project name:** If the project list already contains project names that also occur in the file to be imported, you can decide which project number should appear in the project list.
7. Click **OK**.

*Further steps:*

- Save your configuration before closing.

*Requirements for operating the function:*

- Project numbers enabled in the PBX (for a fee)

# Relays

If the PBX is equipped with one or more relays, they can be switched on and off independently of the operating mode configured for each telephone.

---

## Switching Relays On/Off

---

**Important:** Not available for operation on the PBX COMpact 3000.

---

Switching this on/off can be done as follows:

- Via the telephone menu

### *Requirements:*

- *Knowledge of the telephone, its menu options and the required PIN, if necessary*
- *A switchable relay configured in the PBX*
- *Authorization in the PBX for **Switching of relay***
- *For the subscriber disabled relay mode **PC relay subscriber** in the PBX*

In order to switch a relay on and off, press the function key configured for switching relays.

Or, proceed as described in the following.

1. Press the **menu key** and open the menu **functions > relay**.
2. Select the desired relay based on its name/number.
3. Select the desired option:
  - switch on:** Enables the relay.
  - switch off:** Disables the relay.

---

## Configuring and Operating Function Key for Switching Relays On/Off

---

**Important:** Not available for operation on the PBXs COMpact 2204 USB and COMpact 3000.

---

Press the key to switch to the configured relay on or off or to switch it over.

In addition, when functions are defined on the first key level, the status of the relay is indicated by the corresponding LED.

### LED signalling next to the key:

Green	The relay configured on the key is enabled.
Off	The relay configured on the key is disabled.

The configuration can be carried out as follows:

- Via COMfortel Set
- Via the telephone menu

### Configuring Function Key for Switching Relays via COMfortel Set

#### *Requirements:*

- An open configuration and the required PIN, if necessary
- A switchable relay configured in the PBX
- For the subscriber disabled relay mode **PC relay subscriber** in the PBX

1. Open the page **Function keys > Assign function keys**.
2. Only available in installed extension modules: In the telephone displayed at the top left, click the key group in which you would like to define keys.
3. Click one of the following tabs:
  - Level 1:** Keys are defined on the first key level.
  - Level 2:** Keys are defined on the second key level.
4. Right-click the function key you want to assign.  
A function selection dialogue opens.
5. Select the **Relay** function.

The current settings for defining the key are displayed.

6. Configure the settings dependent on the type of PBX.
  - Select a relay in the **Relays to be switched** list field.
  - Enter the identification number of the relay in question in the **identification number** field.
7. In the **Kind of switching** list field, select one of the following options:
  - switch off**: Press the key to disable the relay.
  - switch on**: Press the key to enable the relay.
  - switch over**: Press the key to switch the relay on and off.
8. In the **Key name** entry field, enter a name for the key. The following entries are possible:
  - Up to 16 digits
  - Digits and characters

Clicking  automatically enters the default name in the entry field.

---

**Note:** The key name is used for printing the label and for display.

---

*Further steps:*

- *Save your configuration before closing.*

*Requirements for operating the function:*

- *Authorization in the PBX for **Switching of relay***

### **Configuring Function Key for Switching Relays via Telephone Menu**

*Requirements:*

- *Knowledge of the telephone, its menu options and the required PIN, if necessary*
- *A switchable relay configured in the PBX*
- *For the subscriber disabled relay mode **PC relay subscriber** in the PBX*

1. Press the **menu key** and open the **define keys** menu.
2. Press the **function key** that you would like to define.

3. Select the desired option:

**first level:** Keys are defined on the first key level.

**second level:** Keys are defined on the second key level.

The list of available functions is displayed.

4. Select the **relay** function.

The current settings for defining the key are shown on the display.

5. Press the  **softkey**.

6. Select a relay based on its name.

7. Select the kind of switching. Press the  **softkey** to switch over between the different kinds of switching.

**switch off:** Press the key to disable the relay.

**switch on:** Press the key to enable the relay.

**switch over:** Press the key to switch the relay on and off.

8. Press the  **softkey** to accept the setting.

*Requirements for operating the function:*

– *Authorization in the PBX for **Switching of relay***



## Room Monitoring

The room monitoring function can be used for monitoring a room acoustically, for instance, for monitoring a small child while she sleeps. The internal telephone in this room must be suitably configured for this purpose.

The configured telephone can then be called by another internal telephone or by a password-protected external telephone. The connection is established immediately and it is possible to listen into the room.

---

### Initiating Room Monitoring

#### *Requirements:*

- *Knowledge of the telephone, its menu options and the required PIN, if necessary*
- *Authorisation in the PBX for **Controlling of the PBX via telephone***

To enable room monitoring, press a **function Key** configured for room monitoring.

Or, proceed as described in the following.

1. Press the **menu key** and open the menu **functions > room monitoring**.
2. Select **switch on**.

The microphone of the hands-free component switches on automatically. If the telephone is then called from an internal telephone, the connection is immediately established and it is possible to listen into the room.

---

**Note:** How to listen into a room from an external telephone is described in the user manual for the PBX.

---

---

### Ending Room Monitoring

- Press the **softkey** ✓ or the **Hook key** or pick up the receiver and then hang it up again.

## Configuring and Operating Function Key for Room Monitoring

Press the key while the telephone is in the idle state to switch on room monitoring.

In addition, when functions are defined on the first key level, the status of the function is indicated by the corresponding LED.

### LED signalling next to the key:

Red	The room monitoring function is enabled.
Off	The room monitoring function is disabled.

The configuration can be carried out as follows:

- Via COMfortel Set
- Via the telephone menu

### Configuring Function Key for Room Monitoring via COMfortel Set

*Requirements:*

– An open configuration and the required PIN, if necessary

1. Open the page **Function keys > Assign function keys**.
2. Only available in installed extension modules: In the telephone displayed at the top left, click the key group in which you would like to define keys.
3. Click one of the following tabs:
  - Level 1:** Keys are defined on the first key level.
  - Level 2:** Keys are defined on the second key level.
4. Right-click the function key you want to assign.  
A function selection dialogue opens.
5. Select the **Room monitoring** function.  
The current settings for defining the key are displayed.

6. In the **Key name** entry field, enter a name for the key. The following entries are possible:

- Up to 16 digits
- Digits and characters

Clicking  automatically enters the default name in the entry field.

---

**Note:** The key name is used for printing the label.

---

*Further steps:*

- *Save your configuration before closing.*

*Requirements for operating the function:*

- *Authorisation in the PBX for **Controlling of the PBX via telephone***

### **Configuring Function Key for Room Monitoring via Telephone Menu**

*Requirements:*

- *Knowledge of the telephone, its menu options and the required PIN, if necessary*

1. Press the **menu key** and open the **define keys** menu.
2. Press the **function key** that you would like to define.
3. Select the desired option:
  - first level:** Keys are defined on the first key level.
  - second level:** Keys are defined on the second key level.The list of available functions is displayed.
4. Select the **room monitoring** function.  
The current settings for defining the key are shown on the display.
5. Press the **softkey**  to accept the setting.

*Requirements for operating the function:*

- *Authorisation in the PBX for **Controlling of the PBX via telephone***

## Scheduled Call

The scheduled call provides the option of being reminded of a schedule or to place a specific call by the system telephone. The telephone can be configured with up to 16 schedules. The configured schedules are saved in a scheduled call list in the order they are to be processed.

---

### Opening Scheduled Call List

Opening can be carried out as follows:

- Via the telephone menu

#### Requirements:

– Knowledge of the telephone, its menu options and the required PIN, if necessary

1. Press the **softkey** and select **schedule**.

Or, press the **function key** configured for a scheduled call or press the **menu key** to open the menu **functions > scheduled call**.



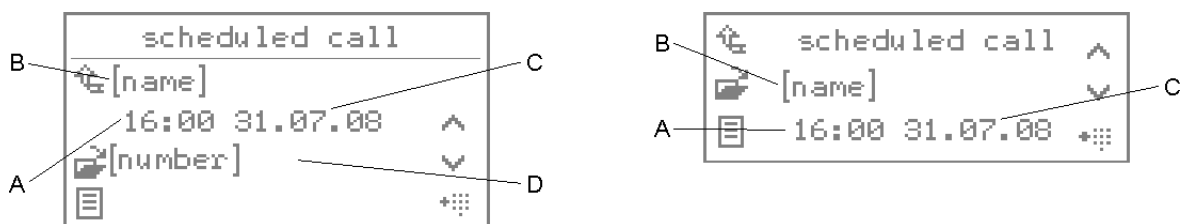

2. Scroll to the desired schedule.

The following information about schedule is shown on the display:



- A Time of the schedule
- B Name of the person to be called or information about the schedule
- C Date of the schedule
- D Phone number of the person to be called

3. Select the desired option:

-  This switches you back to the second level.
-  This initiates either the deletion or editing of the schedule.
-  This opens the short overview.
-  This accepts entries into dial preparation.

---

**Note:** As soon as a phone number is accepted into dial preparation, this schedule is considered completed and is deleted from the scheduled call list.

---

---

## Configuring Scheduled Call as Schedule Reminder

The configuration can be carried out as follows:



- Via the telephone menu

*Requirements:*

– Knowledge of the telephone, its menu options and the required PIN, if necessary

In order to configure a scheduled call that is meant to remind you of a schedule, select the **reschedule call** function during a call.

Or, proceed as described in the following.

1. Open the scheduled call list.
2. Press the  **softkey** in front of **new entry**.
3. Enter the time and date.
4. Press the  **softkey**.
5. Select **just a reminder**.
6. Enter some information. The following entries are possible:
  - Up to 16 digits
  - Digits and characters
7. Press the  **softkey** to save the entry.

---

## Configuring Scheduled Call as Call Reminder

The configuration can be carried out as follows:

- Via the telephone menu



### *Requirements:*

– *Knowledge of the telephone, its menu options and the required PIN, if necessary*

In order to configure a scheduled call that is meant to remind you to make a specific call, select the **reschedule call** function during a call.

If the telephone number is on the caller list, for example, transfer the phone number into dial preparation, and then press the  **softkey**.

Or, proceed as described in the following.

1. Open the scheduled call list.
2. Press the  **softkey** in front of **new entry**.
3. Enter the time and date.
4. Press the  **softkey**.
5. Select **with dial prep..**

---

### **Note:**

If you carry out configuration during a call, the phone number of your communication partner is now display – if it is known.

If you press the **Telephone book key** before entering the phone number, you can select the desired phone number from the telephone book.

---

6. Enter the telephone number that you would like to call later. The following entries are possible:

Up to 40 digits

Digits and the characters \* and #

---

**Important:** Enter telephone numbers exactly as when dialling, for example, external telephone numbers always with a leading exchange line access number. (exception: direct exchange access). The default exchange line access number on the PBX is "0" in the factory settings; however, this can be changed for several PBXs (see the PBX manual).

---

7. Enter the corresponding name or information. The following entries are possible:
  - Up to 16 digits
  - Digits and characters
8. Press the **✓ softkey** to save the entry.

---

## Accepting Scheduled Call as Schedule Reminder

The accepting procedure can be carried out as follows:

- Via the telephone menu

### *Requirements:*

- *Knowledge of the telephone, its menu options and the required PIN, if necessary*

If a schedule call causes your telephone to ring to remind you of a schedule, proceed as described in the following.

1. Select the desired option:
  - confirm:** Confirms the scheduled call.
  - reschedule:** Reschedules the scheduled call for 10 minutes later.
  - reschedule call:** Allows you to reschedule the scheduled call using the options of 30 minutes, 1 hour, 2 hours, 1 day, 1 week, 2 weeks, 4 weeks or a user-defined option.
2. Press the **✓ softkey** to accept the selection.

---

**Note:** If you are not present when the scheduled call occurs, it is automatically rescheduled. As soon as the telephone is operated again afterwards, the scheduled call occurs again 1 minute after returning to the idle state.

---

## Accepting Scheduled Call as Call Reminder

The accepting procedure can be carried out as follows:

- Via the telephone menu

### *Requirements:*

– *Knowledge of the telephone, its menu options and the required PIN, if necessary*

If your telephone rings due to a scheduled call for a call reminder, pick up the receiver to accept the call. The phone number saved is dialled immediately.

Or, proceed as described in the following.

1. Select the desired option:

**dial preparation:** Enters the phone number saved into dial preparation.

**delete:** Deletes the scheduled call.

**reschedule:** Reschedules the scheduled call 10 minutes later.

**reschedule call:** Allows you to reschedule the scheduled call using the options of 30 minutes, 1 hour, 2 hours, 1 day, 1 week, 2 weeks, 4 weeks or a user-defined option.

2. Press the **✓ softkey** to accept the selection.

---

**Note:** If you are not present when the scheduled call occurs, it is automatically rescheduled. As soon as the telephone is operated again afterwards, the scheduled call occurs again 1 minute after returning to the idle state.

---

---

## Editing Existing Scheduled Calls in Scheduled Call List

Editing can be carried out as follows:

- Via the telephone menu

### *Requirements:*

– *Knowledge of the telephone, its menu options and the required PIN, if necessary*



1. Open the scheduled call list.
2. Scroll to the desired schedule.
3. Press the  **softkey**.
4. Select **change**.
5. Make the desired changes.

---



## Deleting Existing Scheduled Calls from Scheduled Call List

Deleting can be carried out as follows:

- Via the telephone menu

### *Requirements:*

– *Knowledge of the telephone, its menu options and the required PIN, if necessary*

1. Open the scheduled call list.
2. Scroll to the desired schedule.
3. Press the  **softkey**.
4. Select **delete**.
5. Press the  **softkey** to confirm the action.

---

## Configuring and Operating Function Key for Scheduled Calls

Press the key while the telephone is the idle state to open the **scheduled call** menu. This allows you to configure a new scheduled call or to open the scheduled call list.

In addition, when functions are defined on the first key level, the status of the function is indicated by the corresponding LED.

**LED signalling next to the key:**

Red (blinking) A scheduled call is signalled.

Red The scheduled call was not accepted/confirmed.

Green One or more scheduled calls are configured.

Off No scheduled call is configured.

The configuration can be carried out as follows:

- Via COMfortel Set
- Via the telephone menu

**Configuring Function Key for Scheduled Calls via COMfortel Set**

*Requirements:*

– An open configuration and the required PIN, if necessary

1. Open the page **Function keys > Assign function keys**.
2. Only available in installed extension modules: In the telephone displayed at the top left, click the key group in which you would like to define keys.
3. Click one of the following tabs:
  - Level 1:** Keys are defined on the first key level.
  - Level 2:** Keys are defined on the second key level.
4. Right-click the function key you want to assign.  
A function selection dialogue opens.
5. Select the **Scheduled call** function.  
The current settings for defining the key are displayed.
6. In the **Key name** entry field, enter a name for the key. The following entries are possible:
  - Up to 16 digits
  - Digits and characters

Clicking  automatically enters the default name in the entry field.

---

**Note:** The key name is used for printing the label.

---

*Further steps:*

- *Save your configuration before closing.*

### **Configuring Function Key for Scheduled Calls via Telephone Menu**

*Requirements:*

- *Knowledge of the telephone, its menu options and the required PIN, if necessary*

1. Press the **menu key** and open the **define keys** menu.
2. Press the **function key** that you would like to define.
3. Select the desired option:

**first level:** Keys are defined on the first key level.

**second level:** Keys are defined on the second key level.

The list of available functions is displayed.

4. Select the **scheduled call** function.  
The current settings for defining the key are shown on the display.
5. Press the **✓ softkey** to accept the setting.

# Speed Dialling

The speed dialling function enables a function key to be defined with not only internal and external phone numbers but also with programming codes on the PBX. The saved codes can be easily dialled by pressing a key, if necessary.

---

## Application Options for Speed Dialling Keys

Speed dialling keys can be used in the following ways:

### Dialling a phone number

Pressing a speed dialling key immediately dials a saved phone number. If the receiver is on hook, the saved phone number is first transmitted into dial preparation.

If a speed dialling key is pressed during a call, a query call is placed and the saved phone number is dialed immediately.

### Dialling part of a phone number

The telephone speed dialling keys to be defined with parts of phone numbers (for example, telephone provider prefixes). The phone number parts can then be assembled by pressing multiple speed dialling keys in an order. The names assigned to the phone numbers are shown one after the other on the display.

### Assignment overview

Speed dialling keys defined with to internal subscriber and group phone numbers enable an overview of the current activity status of the subscriber or group via the corresponding LEDs.

### Pickup and call take-over

Speed dialling keys defined with internal subscriber and group phone numbers enable the pickup function for these subscribers and groups. If the LED next to the key is blinking in red because the saved phone number is being called, you can take the call on your telephone by pressing the speed dialling key and then confirming.

If a subscriber allows call take-over (for example, on an answering machine), you can still take the call on your telephone in the same manner even after it has already been accepted.

---

## Configuring and Operating Function Key for Speed Dialling

Press the key while the telephone is in the idle state to transfer a telephone number saved in a key to dial preparation – also additional information.

Exception: If the telephone number saved is an internal phone number and is currently being called, you can carry out the Pickup function on this call.

After picking up the receiver, press the key to dial the telephone number saved in the key.

Press the key during a call to put the active communication partner on hold and to dial the phone number saved in the key.

In addition, when a subscriber or a group telephone number is defined at the first key level, the status of the subscriber or group can be read from the corresponding LED.

### **LED signalling next to the key (when defined with an internal subscriber telephone number):**

Red (blinking) The internal telephone is now being called. Press the key to initiate a pickup.

Red A call is in progress on the internal telephone. Press the key to initiate a call take-over.

Green (blinking) A call is being made from the internal telephone and the call was not accepted.

Yellow The internal telephone is not reachable (do-not-disturb or call forwarding for subscribers has been configured).

Yellow (blinking) Only for internal VoIP subscriber and enabled display of the registration status: The telephone is not registered on the PBX.

Off The internal telephone is available. Press the key to place a call.

### **LED signalling next to the key (when defined with an internal group phone number):**

Red (blinking) A logged-in telephone is now being called. Press the key to initiate a pickup.

Red Calls are in progress on all logged-in telephones or no telephone in the group is logged in.

Yellow The logged-in telephones are not reachable (do-not-disturb or call forwarding for subscribers has been configured).

Off The logged-in telephones are available. Press the key to place a call.

### **LED signalling next to the key (when defined with an external telephone number):**

Green (blinking) A call is being made from the telephone of the external subscriber and the call was not accepted (in as far as the external telephone number is transmitted).

The configuration can be carried out as follows:

- Via COMfortel Set
- Via the telephone menu

### **Configuring Function Key for Speed Dialling via COMfortel Set**

*Requirements:*

– An open configuration and the required PIN, if necessary

1. Open the page **Function keys > Assign function keys**.
2. Only available in installed extension modules: In the telephone displayed at the top left, click the key group in which you would like to define keys.
3. Click one of the following tabs:
  - Level 1:** Keys are defined on the first key level.
  - Level 2:** Keys are defined on the second key level.
4. Right-click the function key you want to assign.  
A function selection dialogue opens.
5. Select the **Speed dialling** function.  
The current settings for defining the key are displayed.
6. In the **Telephone no** entry field, enter the destination number. The following entries are possible:
  - Up to 24 digits
  - Digits and the characters \* and #

Click  to accept a telephone number from the telephone book in the **Telephone no** entry field.
7. In the **Type of telephone number** list field, select one of the following options:
  - Internal no.:** Defines the destination number entered as an internal telephone number.
  - External no.:** Defines the destination number entered as an external telephone number.

8. In the **Key name** entry field, enter a name for the key. The following entries are possible:

- Up to 16 digits
- Digits and characters

Clicking  automatically enters the default name in the entry field.

---

**Note:** The key name is used for printing the label and for display.

---

*Further steps:*

- *Save your configuration before closing.*

### **Configuring Function Key for Speed Dialling via Telephone Menu**

*Requirements:*

- *Knowledge of the telephone, its menu options and the required PIN, if necessary*

1. Press the **menu key** and open the **define keys** menu.
2. Press the **function key** that you would like to define.
3. Select the desired option:
  - first level:** Keys are defined on the first key level.
  - second level:** Keys are defined on the second key level.

The list of available functions is displayed.

4. Select the **speed dialling** function.

The current settings for defining the key are shown on the display.
5. Press the  **softkey**.

---

**Note:** If you press the **telephone book key** before entering the destination number, you can select the desired phone number from the telephone book.

---

6. Enter the destination number. The following entries are possible:



Up to 24 digits

Digits and the characters \* and #

---

**Important:** Enter telephone numbers exactly as when dialling, for example, external telephone numbers always with a leading exchange line access number. (exception: direct exchange access). The default exchange line access number on the PBX is "0" in the factory settings; however, this can be changed for several PBXs (see the PBX manual).

---

7. Press the  **softkey**.
8. Enter a name. The following entries are possible:
  - Up to 16 digits
  - Digits and characters
9. Press the  **softkey** to accept the setting.

---

## Switching Automatic Speed Dialling Pick-up On/Off

If automatic speed dialling pick-up is enabled, pressing a speed dialling key while the telephone is in the idle state automatically picks up a call (when using a headset) or switches the telephone to hands-free calling.

Switching this on/off can be done as follows:

- Via COMfortel Set
- Via the telephone menu

### Switching Automatic Speed Dialling Pick-up On/Off via COMfortel Set

*Requirements:*

– An open configuration and the required PIN, if necessary

1. Open the page **Settings/functions > User settings**.



2. Select or clear the **Automatic off-hook for speed dialling** check box.
  - Enables automatic speed dialling pick-up.
  - Disables automatic speed dialling pick-up.

*Further steps:*

- *Save your configuration before closing.*

### **Switching Automatic Speed Dialling Pick-up On/Off via Telephone Menu**

*Requirements:*

- *Knowledge of the telephone, its menu options and the required PIN, if necessary*

1. Press the **menu key** and open the menu **settings > user settings > speed dial.key**.
2. Select or clear the **auto. off hook** check box.
  - Enables automatic speed dialling pick-up.
  - Disables automatic speed dialling pick-up.
3. Press the **✓ softkey** to accept the setting.

---

### **Switching the Display of the Registration Status On/Off**

If the display of the registration status is switched on, the individual registration status of the subscribers will be signalled via the LEDs of the speed dialling keys assigned to internal VoIP subscribers. If the corresponding VoIP subscriber is not registered at the PBX, its LED will blink yellow.

Switching this on/off can be done as follows:

- Via COMfortel Set
- Via the telephone menu

### **Switching the Display of the Registration Status On/Off via COMfortel Set**

*Requirements:*

– An open configuration and the required PIN, if necessary

1. Open the page **Settings/functions > signalling/ringer**.
2. Select or clear the **Registration status subscriber** check box.
  - Switches the display of the registration status on.
  - Switches the display of the registration status off.

*Further steps:*

– Save your configuration before closing.

### **Switching the Display of the Registration Status On/Off via Telephone Menu**

*Requirements:*

– Knowledge of the telephone, its menu options and the required PIN, if necessary

1. Press the **menu key** and open the menu **settings > signalling > reg.status scr.**
2. Select or clear the **reg.status scr.** check box.
  - Switches the display of the registration status on.
  - Switches the display of the registration status off.
3. Press the **✓ softkey** to accept the setting.

# Targeted Exchange Line Access

Using targeted exchange line access, you can define which MSN (your own external phone number) is transmitted for an external call and which exchange line should be used while doing so.

---

## Targeted Exchange Line Access Variants

Auerswald PBXs support three different kinds of targeted exchange line access:

### Variant A

---

**Important:** Only available for operation on the PBXs COMpact 3000, COMpact 5010 VoIP, COMpact 5020 VoIP, COMmander Basic.2 and COMmander Business.

---

Targeted exchange line access is carried out and includes the transmission of a specific MSN.

When this function is defined on a key, the status of the  $S_0$  port is indicated by the corresponding LED thereby giving you an overview of key definition.

### Variant B

---

**Important:** Only available for operation on the PBXs COMpact 2204 USB, COMpact 2206 USB, COMpact 4406 DSL, COMpact 4410 USB and COMmander Basic.

---

Targeted exchange line access is carried out along with the transmission of the standard telephone number.

When this function is defined on a key, the status of the  $S_0$  port is indicated by the corresponding LED thereby giving you an overview of key definition.

### Variant C

---

**Important:** Only available for operation on the PBXs COMpact 2204 USB, COMpact 2206 USB, COMpact 4406 DSL, COMpact 4410 USB and COMmander Basic.

---

Targeted exchange line access is carried out and includes the transmission of a specific MSN.

---

## Initiating Targeted Exchange Line Access

Initiation can be carried out as follows:

- Via the telephone menu

### *Requirements:*

- Knowledge of the telephone, its menu options and the required PIN, if necessary
- A function key configured for targeted exchange line access
- For targeted exchange line access with the transmission of a specific MSN: Telephone number transmission activated

1. Press a **function key** configured for targeted exchange line access.
2. Dial a telephone number without an exchange line access number.

---

**Important:** For targeted exchange line access with the transmission of a specific MSN, select an external telephone number with an exchange line access number.

---

3. Pick up the receiver or press the **hook key**.

The subscriber is called.

---

**Note:** If another call comes through before you have finished placing the call, the telephone will reject the targeted exchange line access for your next call.

---

---

## Configuring and Operating Function Key for Targeted Exchange Line Access (A)

---

**Important:** Only available for operation on the PBXs COMpact 3000, COMpact 5010 VoIP, COMpact 5020 VoIP, COMmander Basic.2 and COMmander Business.

---

Press the key to initiate targeted exchange line access. This allows you to immediately dial the external phone number (with an exchange line access number).

Exception: In case of direct exchange access you do not have to dial an exchange line access number.

In addition, when the function is defined on the first key level, the status of the S<sub>0</sub> port/bundle is indicated by the corresponding LED.

**LED signalling next to the key:**

Red	All of the B-channels on the S <sub>0</sub> port/bundle are in use.
Yellow	At least one B-channel on the S <sub>0</sub> port/bundle is available. Press the key to allocate the line still available.
Off	S <sub>0</sub> port/bundle is available. Press the key to allocate one of the available lines.

The configuration can be carried out as follows:

- Via COMfortel Set
- Via the telephone menu

**Configuring Function Key for Targeted Exchange Line Access (A) via COMfortel Set**

*Requirements:*

– *An open configuration and the required PIN, if necessary*

1. Open the page **Function keys > Assign function keys**.
2. Only available in installed extension modules: In the telephone displayed at the top left, click the key group in which you would like to define keys.
3. Click one of the following tabs:
  - Level 1:** Keys are defined on the first key level.
  - Level 2:** Keys are defined on the second key level.
4. Right-click the function key you want to assign.  
A function selection dialogue opens.
5. Select the **Exchange line** function.  
The current settings for defining the key are displayed.

6. In the **Telephone no** entry field, enter the external telephone number for the PBX that you want to transfer during targeted exchange line access.

Up to 24 digits

Digits and the characters \* and #

7. In the **Key name** entry field, enter a name for the key. The following entries are possible:

Up to 16 digits

Digits and characters

Clicking  automatically enters the default name in the entry field.

---

**Note:** The key name is used for printing the label and for display.

---

*Further steps:*

- *Save your configuration before closing.*

### **Configuring Function Key for Targeted Exchange Line Access (A) via Telephone Menu**

*Requirements:*

- *Knowledge of the telephone, its menu options and the required PIN, if necessary*

1. Press the **menu key** and open the **define keys** menu.

2. Press the **function key** that you would like to define.

3. Select the desired option:

**first level:** Keys are defined on the first key level.



**second level:** Keys are defined on the second key level.

The list of available functions is displayed.

4. Select the **exchange line** function.

The current settings for defining the key are shown on the display.

5. Press the  **softkey**.

6. Enter the PBX external telephone number that you want to transmit during targeted exchange line access (without an exchange line access number and without a prefix). The following entries are possible:
  - Up to 24 digits
  - Digits and the characters \* and #
7. Press the  **softkey**.
8. Enter a name. The following entries are possible:
  - Up to 16 digits
  - Digits and characters
9. Press the  **softkey** to accept the setting.

---

## Configuring and Operating Function Key for Targeted Exchange Line Access (B)

---

**Important:** Only available for operation on the PBXs COMpact 2204 USB, COMpact 2206 USB, COMpact 4406 DSL, COMpact 4410 USB and COMmander Basic.

---

Press the key to initiate targeted exchange line access. This allows you to immediately dial the external telephone number (without an exchange line access number).

In addition, when the function is defined on the first key level, the status of the S<sub>0</sub> port is indicated by the corresponding LED.

### LED signalling next to the key:

Red	Both B-channels on the S <sub>0</sub> port are in use.
Yellow	One B-channel on the S <sub>0</sub> port is still available. Press the key to allocate the line still available.
Off	S <sub>0</sub> port is available. Press the key to allocate one of the available lines.

The configuration can be carried out as follows:

- Via COMfortel Set
- Via the telephone menu

## **Configuring Function Key for Targeted Exchange Line (B) Access via COMfortel Set**

### *Requirements:*

– *An open configuration and the required PIN, if necessary*

1. Open the page **Function keys > Assign function keys**.
2. Only available in installed extension modules: In the telephone displayed at the top left, click the key group in which you would like to define keys.
3. Click one of the following tabs:
  - Level 1:** Keys are defined on the first key level.
  - Level 2:** Keys are defined on the second key level.
4. Right-click the function key you want to assign.  
A function selection dialogue opens.
5. Select the **Exchange line** function.  
The current settings for defining the key are displayed.
6. In the **B channel** list field, select the exchange line that you would like to use during targeted exchange line access.
7. In the **Key name** entry field, enter a name for the key. The following entries are possible:
  - Up to 16 digits
  - Digits and characters

Clicking  automatically enters the default name in the entry field.

---

**Note:** The key name is used for printing the label and for display.

---

### *Further steps:*



– *Save your configuration before closing.*



## **Configuring Function Key for Targeted Exchange Line Access (B) via Telephone Menu**

### *Requirements:*

– Knowledge of the telephone, its menu options and the required PIN, if necessary

1. Press the **menu key** and open the **define keys** menu.
2. Press the **function key** that you would like to define.
3. Select the desired option:
  - first level:** Keys are defined on the first key level.
  - second level:** Keys are defined on the second key level.The list of available functions is displayed.
4. Select the **exchange line** function.  
The current settings for defining the key are shown on the display.
5. Press the  **softkey**.
6. Select the exchange line from the list that you want to use for targeted exchange line access.
7. Press the  **softkey** to accept the setting.

---

## **Configuring and Operating Function Key for Targeted Exchange Line Access (C)**

---

**Important:** Only available for operation on the PBXs COMpact 2204 USB, COMpact 2206 USB, COMpact 4406 DSL, COMpact 4410 USB and COMmander Basic.

---

Press the key to initiate targeted exchange line access. This allows you to immediately dial the external telephone number (with an exchange line access number).

In addition, when functions are defined on the first key level, the status of the function is indicated by the corresponding LED.

**LED signalling next to the key:**

- |       |   |
|-------|---|
| Green | The MSN on the key is transmitted during the next outgoing external call. |
| Off   | The standard telephone number transmitted during the next outgoing call.  |

The configuration can be carried out as follows:

- Via COMfortel Set
- Via the telephone menu

**Configuring Function Key for Targeted Exchange Line Access (C) via COMfortel Set**

*Requirements:*

– An open configuration and the required PIN, if necessary

1. Open the page **Function keys > Assign function keys**.
2. Only available in installed extension modules: In the telephone displayed at the top left, click the key group in which you would like to define keys.
3. Click one of the following tabs:
  - Level 1:** Keys are defined on the first key level.
  - Level 2:** Keys are defined on the second key level.
4. Right-click the function key you want to assign.  
A function selection dialogue opens.
5. Select the **Exchange line MSN** function.  
The current settings for defining the key are displayed.
6. In the **Telephone no** entry field, enter the external telephone number for the PBX that you want to transfer during targeted exchange line access.
  - Up to 24 digits
  - Digits and the characters \* and #

7. In the **Key name** entry field, enter a name for the key. The following entries are possible:

Up to 16 digits

Digits and characters

Clicking  automatically enters the default name in the entry field.

---

**Note:** The key name is used for printing the label and for display.

---



*Further steps:*

- *Save your configuration before closing.*

### **Configuring Function Key for Targeted Exchange Line Access (C) via Telephone Menu**

*Requirements:*

- *Knowledge of the telephone, its menu options and the required PIN, if necessary*

1. Press the **menu key** and open the **define keys** menu.
2. Press the **function key** that you would like to define.
3. Select the desired option:
  - first level:** Keys are defined on the first key level.
  - second level:** Keys are defined on the second key level.The list of available functions is displayed.
4. Select the **exchange line MSN** function.  
The current settings for defining the key are shown on the display.
5. Press the  **softkey**.
6. Enter the PBX external telephone number that you want to transmit during targeted exchange line access (without an exchange line access number and without a prefix).  
The following entries are possible:
  - Up to 24 digits
  - Digits and the characters \* and #
7. Press the  **softkey**.

## Configuring and Operating Functions

Targeted Exchange Line Access

Configuring and Operating Function Key for Targeted Exchange Line Access (C)

8. Enter a name. The following entries are possible:

Up to 16 digits

Digits and characters

9. Press the  **softkey** to accept the setting.

# Targeted VoIP Access Point

Using a targeted VoIP access point, an external call can be initiated via a specific VoIP account.

---

## Initiating a Targeted VoIP Access Point

---

**Important:** Only available for operation on the PBXs COMpact 3000, COMpact 5010 VoIP, COMpact 5020 VoIP, COMmander Basic.2 and COMmander Business.

---

Initiation can be carried out as follows:

- Via the telephone menu

### *Requirements:*

- Knowledge of the telephone, its menu options and the required PIN, if necessary
- Configured function key for a targeted VoIP access point

1. Press a **function key** configured for a targeted VoIP access point.

The VoIP account is activated for the next call. The account number is displayed in dial preparation.

2. Dial a phone number (an external phone number with an exchange line access number).

---

### **Note:**

In any case, the external phone number must be dialled with the corresponding city code, even if it is the local prefix. The special numbers provided by the VoIP provider for checking one's account status or dialling usually do not include a local prefix.

In case of direct exchange access you do not have to dial an exchange line access number.

---

3. Pick up the receiver or press the **Hook key**.

The subscriber is called.

---

## Configuring and Operating Function Key for Targeted VoIP Access Point

---

**Important:** Only available for operation on the PBXs COMpact 3000, COMpact 5010 VoIP, COMpact 5020 VoIP, COMmander Basic.2 and COMmander Business.

---

Press the key to initiate a targeted VoIP access point. This allows you to immediately dial the external phone number (with an exchange line access number).

Exception: In case of direct exchange access you do not have to dial an exchange line access number.

In addition, when a targeted VoIP access point is defined on the first key level, the status of the channels for the targeted VoIP access point is indicated by the corresponding LED.

### LED signalling next to the key:

Red	All of the channels for the VoIP access point are in use (no call possible).
Yellow	Some of the channels for the VoIP access point are in use (at least one channel for the VoIP access line is still available). Press the key to allocate the channel still available.
Off	All channels for the VoIP access point are available. Press the key to allocate an available channel.

The configuration can be carried out as follows:

- Via COMfortel Set
- Via the telephone menu

### Configuring Function Key for Targeted VoIP Access Point via COMfortel Set

*Requirements:*

– *An open configuration and the required PIN, if necessary*

1. Open the page **Function keys > Assign function keys**.
2. Only available in installed extension modules: In the telephone displayed at the top left, click the key group in which you would like to define keys.

3. Click one of the following tabs:
  - Level 1:** Keys are defined on the first key level.
  - Level 2:** Keys are defined on the second key level.
4. Right-click the function key you want to assign.  
A function selection dialogue opens.
5. Select the **VoIP account** function.  
The current settings for defining the key are displayed.
6. In the **Telephone no** entry field, enter the account number for the VoIP account.  
Exception: For a direct exchange line access device, enter the account number starting with two leading asterisks (\*\*account number).
7. In the **Key name** entry field, enter a name for the key. The following entries are possible:
  - Up to 16 digits
  - Digits and characters

Clicking  automatically enters the default name in the entry field.

---

**Note:** The key name is used for printing the label and for display.

---

*Further steps:*

- *Save your configuration before closing.*

### **Configuring Function Key for Targeted VoIP Access Point via Telephone Menu**

*Requirements:*

- *Knowledge of the telephone, its menu options and the required PIN, if necessary*
- *A configured VoIP account*

1. Press the **menu key** and open the **define keys** menu.
2. Press the **function key** that you would like to define.

3. Select the desired option:

**first level:** Keys are defined on the first key level.

**second level:** Keys are defined on the second key level.

The list of available functions is displayed.

4. Select the **VoIP account** function.

The current settings for defining the key are shown on the display.

5. Press the  **softkey**.

6. Select a VoIP account from the list.

7. Press the  **softkey**.

8. Change the name, if necessary. The following entries are possible:

Up to 16 digits

Digits and characters

9. Press the  **softkey** to accept the setting.



# Text before Answering

The text before answering function enables the caller to be greeted with an automatic announcement before accepting the call (charges apply for the external caller).

---

## Variants for Text before Answering

### Text before answering for group

---

**Important:** Only available for operation on the PBXs COMpact 5010 VoIP, COMpact 5020 VoIP, COMmander Basic.2 and COMmander Business.

---

Switching the text before answering function on is done separately for each group.

There are two types possible:

- Text before answering on busy  
The caller hears the announcement for text before answering only if all of the group members are busy. After this, the caller is automatically connected to the corresponding queue.
- Text before answering always  
The caller hears the announcement independent of whether the group members are being called or are busy. If all of the group members are busy, the caller is automatically connected to the corresponding queue.

### Text before answering for external telephone number

---

**Important:** Only available for operation on the PBXs COMpact 4406 DSL, COMpact 4410 USB and COMmander Basic.

---

Switching the text before answering function on is done separately for each external telephone number.

---

## Switching Text before Answering for Group On/Off

---

**Important:** Only available for operation on the PBXs COMpact 5010 VoIP, COMpact 5020 VoIP, COMmander Basic.2 and COMmander Business.

---

*Requirements:*

- *Function key configured for the text before answering function*
- *The text before answering announcement on the PBX assigned to the group*

- Press the **function key** configured for the text before answering function.

---

## Configuring and Operating Function Key for Text before Answering for Group

---

**Important:** Only available for operation on the PBXs COMpact 5010 VoIP, COMpact 5020 VoIP, COMmander Basic.2 and COMmander Business.

---

Press the key while the telephone is the idle state to switch text before answering for the configured group on or off or to switch it over.

In addition, when functions are defined on the first key level, the status of the function is indicated by the corresponding LED.

**LED signalling next to the key:**

- |       |  |
|-------|--|
| Green | The text before answering function for the configured group is enabled.  |
| Off   | The text before answering function for the configured group is disabled. |

The configuration can be carried out as follows:

- Via COMfortel Set
- Via the telephone menu

## **Configuring Function Key for Text before Answering via COMfortel Set**

### *Requirements:*

- An open configuration and the required PIN, if necessary
- The telephone is a member of a group configured in the PBX

1. Open the page **Function keys > Assign function keys**.
2. Only available in installed extension modules: In the telephone displayed at the top left, click the key group in which you would like to define keys.
3. Click one of the following tabs:
  - Level 1:** Keys are defined on the first key level.
  - Level 2:** Keys are defined on the second key level.
4. Right-click the function key you want to assign.  
A function selection dialogue opens.
5. Select the **Text before answering** function.  
The current settings for defining the key are displayed.
6. In the **Telephone no** entry field, enter the phone number of the group.
7. In the **Kind of switching** list field, select one of the following options:
  - switch off:** Press the key to disable text before answering.
  - switch on (on busy):** Press the key to enable text before answering on busy.
  - switch on (always):** Press the key to enable text before answering.
  - switch over (on busy):** Press the key to switch text before answering on busy on and off.
  - switch over (always):** Press the key to switch text before answering on and off.
8. In the **Key name** entry field, enter a name for the key. The following entries are possible:
  - Up to 16 digits
  - Digits and characters

Clicking  automatically enters the default name in the entry field.

---

**Note:** The key name is used for printing the label and for display.

---

*Further steps:*

- *Save your configuration before closing.*



*Requirements for operating the function:*

- *The text before answering announcement on the PBX and assigned to the group*

### **Configuring Function Key for Text before Answering via Telephone Menu**

*Requirements:*

- *Knowledge of the telephone, its menu options and the required PIN, if necessary*
- *The telephone is a member of a group configured in the PBX*

1. Press the **menu key** and open the **define keys** menu.
2. Press the **function key** that you would like to define.
3. Select the desired option:
  - first level:** Keys are defined on the first key level.
  - second level:** Keys are defined on the second key level.The list of available functions is displayed.
4. Select the **text before answering** function.  
The current settings for defining the key are shown on the display.
5. Press the  **softkey**.
6. Select a group based on its name/number.
7. Press the  **softkey**.
8. Enter a name for the group. The following entries are possible:
  - Up to 16 digits
  - Digits and characters
9. Select the kind of switching. Press the  **softkey** to switch over between the different kinds of switching.
  - deactivate:** Press the key to disable text before answering.
  - sw.on (on busy):** Press the key to enable text before answering on busy.

**sw.on (always)** Press the key to enable text before answering.

**sw.on (on busy):** Press the key to switch text before answering on busy on and off.

**sw.on (always)** Press the key to switch text before answering on and off.

10. Press the  **softkey** to accept the setting.

*Requirements for operating the function:*

- The text before answering announcement on the PBX and assigned to the group

---

## Switching Text before Answering for External Telephone Number On/Off

---

**Important:** This function is only available for operation on the PBXs COMpact 4406 DSL, COMpact 4410 USB and COMmander Basic.

---

*Requirements:*

- Function key configured for the text before answering function
- Text before answering announcement saved on the PBX

- Press the **function key** configured for the text before answering function.

---

## Configuring and Operating Function Key for Text before Answering for External Telephone Number

---

**Important:** This function is only available for operation on the PBXs COMpact 4406 DSL, COMpact 4410 USB and COMmander Basic.

---

Press the key while the telephone is the idle state to switch text before answering for the configured telephone number on or off or to switch it over.

In addition, when functions are defined on the first key level, the status of the function is indicated by the corresponding LED.

**LED signalling next to the key:**

Green	The text before answering function for the configured telephone number is enabled.
Off	The text before answering function for the configured telephone number is disabled.

The configuration can be carried out as follows:

- Via COMfortel Set
- Via the telephone menu

**Configuring Function Key for Text before Answering via COMfortel Set**

*Requirements:*

– An open configuration and the required PIN, if necessary

1. Open the page **Function keys > Assign function keys**.
2. Only available in installed extension modules: In the telephone displayed at the top left, click the key group in which you would like to define keys.
3. Click one of the following tabs:
  - Level 1:** Keys are defined on the first key level.
  - Level 2:** Keys are defined on the second key level.
4. Right-click the function key you want to assign.  
A function selection dialogue opens.
5. Select the **Text before answering** function.  
The current settings for defining the key are displayed.
6. In the **Telephone no (your own exchange line)** entry field, enter the external telephone number on the PBX.
  - Up to 24 digits
  - Digits and the characters \* and #

7. In the **Kind of switching** list field, select one of the following options:
  - switch off:** Press the key to disable text before answering.
  - switch on:** Press the key to enable text before answering.
  - switch over:** Press the key to switch text before answering on and off.
8. In the **Key name** entry field, enter a name for the key. The following entries are possible:
  - Up to 16 digits
  - Digits and characters

Clicking  automatically enters the default name in the entry field.

---

**Note:** The key name is used for printing the label and for display.

---

*Further steps:*

- *Save your configuration before closing.*

*Requirements for operating the function:*





- *Text before answering announcement saved on the PBX*

### **Configuring Function Key for Text before Answering via Telephone Menu**

*Requirements:*

- *Knowledge of the telephone, its menu options and the required PIN, if necessary*

1. Press the **menu key** and open the **define keys** menu.
2. Press the **function key** that you would like to define.
3. Select the desired option:
  - first level:** Keys are defined on the first key level.
  - second level:** Keys are defined on the second key level.The list of available functions is displayed.
4. Select the **text bef. answer** function.  
The current settings for defining the key are shown on the display.

5. Press the  **softkey**.
6. Select the external telephone number on the PBX.
7. Press the  **softkey**.
8. Enter a name for the group. The following entries are possible:
  - Up to 16 digits
  - Digits and characters
9. Select the kind of switching. Press the  **softkey** to switch over between the different kinds of switching.
  - switch off:** Press the key to disable text before answering.
  - switch on:** Press the key to enable text before answering.
  - switch over:** Press the key to switch text before answering on and off.
10. Press the  **softkey** to accept the setting.

*Requirements for operating the function:*

- *Text before answering announcement saved on the PBX*



## Voicemail Center 461/461.2

If a Voicemail Center 461/461.2 (optional accessory from Auerswald) is connected to an Auerswald PBX, its mailboxes can be accessed/managed over the system telephone.

---

### Initiating Remote Access to Voicemail Center

Initiation can be carried out as follows:

- Via the telephone menu

#### *Requirements:*

- *Knowledge of the telephone, its menu options and the required PIN, if necessary*
- *At least one Voicemail Center 461/461.2 connected to the PBX*

To initiate remote access to the Voicemail Center, press the **☰ softkey** and select **Voicemail**.

Or, press a **function key** configured for remotely accessing the Voicemail Center.

---

**Important:** Refer to the following instructions for a complete description on how to configure and operate the function: "Instructions for operation on Auerswald PBXs" for the Voicemail Center 461.2 or the corresponding user manual for the Voicemail Center 461.

---

---

### Configuring and Operating Function Key for Remotely Accessing the Voicemail Center

Press the key for general functions while the telephone is in the idle state to open the menu for selecting between global mailbox or single mailbox. After selecting the mailbox, entering the following associated remote access code and picking up the receiver, you are connected with the configured Voicemail Center 461/461.2. If new recordings are present, they are played back immediately. You can operate the Voicemail Center 461/461.2 using the softkeys.

While the telephone is in the idle state, press the key defined for accessing the function and then pick up the receiver to establish a connection to mailbox set in the configured Voicemail Center 461/461.2. If new recordings are present, they are played back immediately. You can operate the Voicemail Center 461/461.2 using the softkeys.

It is possible to press the key while a connection exists with the Voicemail Center 461/461.2 to pick up the call.

In addition, when functions are defined on the first key level, the status of the function is indicated by the corresponding LED.

#### **LED signalling next to the key:**

Red (blinking) The Voicemail Center 461/461.2 is called.

Red The Voicemail Center 461/461.2 has accepted the call. Press the key to initiate a pick-up to accept the call.

Green (blinking) New recordings are present (applies to a key defined only for the preconfigured mailbox; for a key configured for general functions, it applies for all of the mailboxes).

Green Old recordings are present (applies to a key defined only for the preconfigured mailbox; for a key configured for general functions, it applies for all of the mailboxes).

The configuration can be carried out as follows:

- Via COMfortel Set
- Via the telephone menu

### **Configuring Function Key for General Remote Access of Voicemail Center via COMfortel Set**

#### *Requirements:*

– An open configuration and the required PIN, if necessary

1. Open the page **Function keys > Assign function keys**.
2. Only available in installed extension modules: In the telephone displayed at the top left, click the key group in which you would like to define keys.

3. Click one of the following tabs:

**Level 1:** Keys are defined on the first key level.

**Level 2:** Keys are defined on the second key level.

4. Right-click the function key you want to assign.

A function selection dialogue opens.

5. Select the **Voicemail Center** function.

The current settings for defining the key are displayed.

6. In the **Telephone no** entry field, enter the telephone number of the Voicemail Center.

7. In the **Key name** entry field, enter a name for the key. The following entries are possible:

Up to 16 digits

Digits and characters

Clicking  automatically enters the default name in the entry field.

---

**Note:** The key name is used for printing the label.

---

*Further steps:*

- *Save your configuration before closing.*

*Requirements for operating the function:*

- *At least one Voicemail Center 461/461.2 connected to the PBX*

### **Configuring Function Key for Defined Remote Access of Voicemail Center via COMfortel Set**

*Requirements:*

- *An open configuration and the required PIN, if necessary*
- *At least one Voicemail Center 461/461.2 connected to the PBX*

1. Open the page **Function keys > Assign function keys**.

2. Only available in installed extension modules: In the telephone displayed at the top left, click the key group in which you would like to define keys.
3. Click one of the following tabs:
  - Level 1:** Keys are defined on the first key level.
  - Level 2:** Keys are defined on the second key level.
4. Right-click the function key you want to assign.  
A function selection dialogue opens.
5. Select the **Defined Voicemail Center** function.  
The current settings for defining the key are displayed.
6. In the **Telephone no** entry field, enter the telephone number of the Voicemail Center.
7. In the list field, select one of the following options:
  - Global mailbox:** Defines that the global mailbox will be accessed.
  - Single mailbox:** Defines that a single mailbox will be accessed.
8. Only when the option **Single mailbox** is selected: In the **Individual mailbox for subscriber telephone number** entry field, enter the subscriber telephone number that is assigned to the single mailbox.

---

**Important:** If you let call a group on the PBX and redirect this group to the Voicemail Center, you have to enter the group telephone number in the **Individual mailbox for subscriber telephone number** entry field.

---

9. In the **Remote control code** entry field, enter the remote access code for the mailbox.

---

**Note:**

When selecting **Single mailbox**, you need to use the remote access code entered at the following location: in the Voicemail Center 461.2 under **create mailboxes > ...mailbox > remote access** or in the Voicemail Center 461 under **mailboxes > remote control code**.

When selecting **Global mailbox**, you need to use the remote access code entered at the following location: In the Voicemail Center 461.2 under **settings > remote access > remote access code** or in the Voicemail Center 461 under **settings > remote access code**.

---

10. In the **Key name** entry field, enter a name for the key. The following entries are possible:

Up to 16 digits

Digits and characters

Clicking  automatically enters the default name in the entry field.

---

**Note:** The key name is used for printing the label and for display.

---

*Further steps:*

- *Save your configuration before closing.*

### **Configuring Function Key for Remotely Accessing the Voicemail Center via Telephone Menu**

*Requirements:*

- *Knowledge of the telephone, its menu options and the required PIN, if necessary*
- *At least one Voicemail Center 461/461.2 connected to the PBX*

1. Press the **menu key** and open the **define keys** menu.
2. Press the **function key** that you would like to define.
3. Select the desired option:

**first level:** Keys are defined on the first key level.

**second level:** Keys are defined on the second key level.

The list of available functions is displayed.





4. Select the **Voicemail Center** function.

The current settings for defining the key are shown on the display.

5. Select the kind of key. Press the  **softkey** to switch over between the different kinds of keys.

**general:** Press the key to open the menu for the selecting the type of mailbox. Then after entering the remote access code, a connection can be established to the configured Voicemail Center.

**defined:** Press the key and then pick up the receiver to establish a connection to a specific mailbox in the configured Voicemail Center.

6. Press the  **softkey**.
7. Select a Voicemail Center 461/461.2 using its name/number.
8. Press the  **softkey**.
9. Enter a name for the Voicemail Center 461/461.2. The following entries are possible:
  - Up to 16 digits
  - Digits and characters
10. Only when the kind of key **defined** has been selected: Select the type of mailbox. Press the  **softkey** to switch over between the different kinds of mailboxes.
  - global mailbox:** Defines that the global mailbox will be accessed.
  - private mailbox:** Defines that a single mailbox will be accessed.
  - a) Only when the type of mailbox **private mailbox** is selected: Press the  **softkey**.
  - b) Select the subscriber whose calls should be rerouted using its name/number.
11. Press the  **softkey**.
12. Enter the remote access code for the mailbox.

---

**Note:**

When selecting **Single mailbox**, you need to use the remote access code entered at the following location: in the Voicemail Center 461.2 under **create mailboxes > ...mailbox > remote access** or in the Voicemail Center 461 under **mailboxes > remote control code**.

When selecting **Global mailbox**, you need to use the remote access code entered at the following location: In the Voicemail Center 461.2 under **settings > remote access > remote access code** or in the Voicemail Center 461 under **settings > remote access code**.

---

13. Press the  **softkey** to accept the setting.

---

## Switching Rapid Remote Access of Voicemail Centers 461.2 On/Off

Compared to the Voicemail Center 461, the Voicemail Center 461.2 with firmware version 2.02 and higher supports more rapid remote access over the telephone. If you would like to take advantage of this, update the firmware for the existing Voicemail Center 461.2 and enable rapid remote access on the telephone.

---

**Note:** If you would also like to use the telephone to operate the Voicemail Center 461, disable rapid remote access to prevent making mistakes when accessing the device.

---

Switching this on/off can be done as follows:

- Via COMfortel Set
- Via the telephone menu

### Switching Rapid Remote Access on Voicemail Center 461.2 On/Off via COMfortel Set

*Requirements:*

– *An open configuration and the required PIN, if necessary*

1. Open the page **Settings/functions > Basic settings**.
2. Select or clear the **Voicemail Center 461.2 with firmware >= 2.02** check box.
  - Enables rapid remote access.
  - Disables rapid remote access.

*Further steps:*

– *Save your configuration before closing.*

### Switching Rapid Remote Access on Voicemail Center 461.2 On/Off via Telephone Menu

*Requirements:*

– *Knowledge of the telephone, its menu options and the required PIN, if necessary*

1. Press the **Menu** key and open the menu **settings > def. settings > VMC461.2FW>=2.02**.

## Configuring and Operating Functions

Voicemail Center 461/461.2

Switching Rapid Remote Access of Voicemail Centers 461.2 On/Off

2. Select or clear the **VMC461.2FW>=2.02** check box.
  - Enables rapid remote access.
  - Disables rapid remote access.
3. Press the **✓ softkey** to accept the setting.



# Waiting Field Function

In a waiting field, callers can be parked either automatically or by pressing the key, and then individually retrieved and forwarded.

---

## Configuring a Waiting Field

---

**Important:** Only available for operation on the PBXs COMpact 4406 DSL, COMpact 4410 USB, COMmander Basic, COMpact 5020 VoIP, COMmander Basic.2 and COMmander Business.

---

The waiting field is configured as described in the following:

- Use the configuration manager in the PBX to configure automatic call acceptance for the waiting field.

---

**Important:** Only available for operation on the PBXs COMpact 5020 VoIP, COMmander Basic.2 and COMmander Business.

---

- Using the configuration manager or the configuration software on the PBX, select a system telephone as the waiting field reception.

---

**Note:**

For operation on the PBXs COMpact 5020 VoIP, COMmander Basic.2 and COMmander Business, a group must be configured and selected as the waiting field reception in order to operate the waiting field with multiple waiting field receptions. The maximum number of waiting field receptions is limited by the number of possible group members.

For operation on the PBXs COMpact 4406 DSL and COMpact 4410 USB, a max. of 1 waiting field reception is possible. For operation on the PBX COMmander Basic, a max. of 4 waiting field receptions is possible.

If multiple system telephones have been configured and enabled as waiting field receptions, multiple employees can operate the waiting field simultaneously. Incoming calls and waiting callers are then signalled in all the waiting

field receptions. However, if someone is talking to a caller in one of the waiting field receptions, this caller is not signalled in the other waiting field receptions.

---

- On each waiting field reception telephone, assign one or more external waiting field keys, which can be used to monitor and process exchange line calls.
- 

**Note:**

For operation on the PBXs COMpact 4406 DSL, COMpact 4410 USB and COMmander Basic, each waiting field key is assigned to an S<sub>0</sub> port.

For operation on the PBXs COMpact 5020 VoIP, COMmander Basic.2 and COMmander Business, each waiting field key is assigned to a bundle. A bundle can be either an S<sub>0</sub> port, multiple bundled S<sub>0</sub> ports, an S<sub>2M</sub> port or a VoIP account. After selecting the bundle, the keys are assigned dynamically. This offers the option of configuring only one key for an S<sub>0</sub> port and only so many keys for an S<sub>2M</sub> port that can be processed at a time. If calls come in over a bundle, they are displayed on the associated available keys. If more multiple calls come in over a bundle than there are keys available, they are not displayed until a key becomes available.

The number of possible waiting field keys depends on the number of existing external lines/B-channels and therefore the maximum possible number of simultaneous callers. See also the PBX manual.

---

- Assign an internal waiting field key to each waiting field reception, with which internal calls (also alarm calls and door calls) are monitored and processed.
- 

**Important:** Only available for operation on the PBXs COMpact 5020 VoIP, COMmander Basic.2 and COMmander Business. For operation on the PBXs COMpact 4406 DSL, COMpact 4410 USB and COMmander Basic, internal calls, alarm calls and door terminal calls to the waiting field reception telephone are only possible if there are no external callers in the waiting field.

---

- After configuring a waiting field key on a system telephone, the waiting field reception function on the system telephone in question is automatically enabled and can be switched on and off, if necessary.

---

## Sequence for Call Acceptance in Waiting Field

Call acceptance in the waiting field is carried out as follows:

- If all of the waiting field receptions have been switched off, the telephones ring according to normal call distribution.
- After switching on one or more waiting field receptions, the calls in the respective waiting field are signalled on the waiting field keys of the enabled waiting field receptions.

---

### **Important:**

After switching on the waiting field reception, any call forwarding for subscribers configured for the telephone, parallel calls as well as the do-not-disturb function are switched off. Not until the waiting field reception is switched off (on the telephone) will these functions (for example, call forwarding on an answering machine) become available again. The function in question (except parallel calling) must be switched on again.

For existing calls, incoming exchange line calls are signalled by blinking LEDs and also by an attention tone, if enabled. For multiple active waiting field receptions, a caller placed in the waiting field is also signalled in the other waiting field receptions by the attention tone.

---

- The caller can be accepted normally by picking up the receiver or placed in the waiting field by pressing the associated waiting field key. If the automatic call acceptance is set to on busy or according to a time, callers are also automatically placed in the waiting field.
- A caller who has been placed in the waiting field, hears hold music. If a group is configured as waiting field reception and text before answering is enabled, the caller hears the text before answering announcement first.
- A caller is kept a max. of 16 minutes without interruption in the waiting field. If the waiting time is not interrupted by a call to the waiting caller or the call is forwarded, the connection is disconnected.
- You are reminded that the subscriber is still waiting by a short tone once per minute.
- Press the corresponding waiting field key to initiate a call with a caller in the waiting field.
- An external caller in the waiting field can be rerouted internally as normal. If the line of the person being called is busy, the external subscriber can be placed in that person's queue. If the person being called does not accept the call, the external caller is put back in the waiting field. This is signalled by an attention tone, if enabled.
- If there is no one in the waiting field, you can make calls as normal and use the keys on the telephone without limitations.

- As long as information about a call in the queue is showing on the display (LED lights up in yellow), several of the keys are without function and as soon as you picked up the receiver, you are connected to the call in the queue. You can prevent this by pressing the **Exit** key. After this, the LED lights up in red and the display is in the idle state. Now you can make a call as normal, for instance, by selecting a phone number from the telephone book.

---

## Switching Waiting Field Reception On/Off

Switching this on/off can be done as follows:

- Via the telephone menu

### *Requirements:*

- Knowledge of the telephone, its menu options and the required PIN, if necessary
- The telephone has been selected in the PBX as a waiting field reception

In order to switch the waiting field reception on or off, press the **function key** configured for the waiting field reception.

Or, proceed as described in the following.

1. Press the **menu key** and open the menu **functions > w.fld.reception**.

The ● icon indicates the current setting.

2. Select the desired option:

**switch on:** Enables the waiting field reception.

**switch off:** Disables the waiting field reception.

---

### **Important:**

It is only possible to switch a waiting field reception off if no callers are in the waiting field. For multiple waiting field receptions, this limitation only applies when only one waiting field reception is switched on.

For operation on the PBXs COMpact 5020 VoIP, COMmander Basic.2 and COMmander Business: When the waiting field reception is switched off, the subscriber is automatically logged out of the waiting field group incoming; the subscriber is automatically logged on again when the waiting field reception is switched on again.

For operation on the PBXs COMpact 4406 DSL, COMpact 4410 USB and COMmander Basic: When the waiting field reception is enabled, the subscriber is automatically logged out of all groups. After disabling it, the participant must be logged in again, if desired.

---

---

## Configuring and Operating Function Key and External Waiting Field

Press the key to place the caller signalled by the key in the waiting field or establish a connection with the caller from the waiting field. Whether you press the key depends on the current status as displayed by the LED next to the key. Refer to the description of LED signalling.

### LED signalling next to the key:

- |                   |   |
|-------------------|---|
| Green             | No connection with an external subscriber exists. Information about the communication partner is shown on the display:<br>(If other waiting field receptions have been enabled, the communication partners for these are not signalled.)<br>Press the key once to place the communication partner in the waiting field. |
| Yellow            | An external subscriber is on hold in the waiting field. Information about the calls waiting are shown on the display:<br>(If other waiting field receptions have been enabled, the LED lights up in red.)<br>Press the key once to establish a connection to the call waiting.  |
| Red               | An external subscriber is on hold in the waiting field.<br>Press the key once to display information about the call waiting – if no call is in progress.  |
| Yellow (blinking) | An external subscriber is calling. Information about the caller is shown on the display:<br>Press the key once to place the caller in the waiting field.<br>Press the key twice to establish a connection to the caller.  |
| Red (blinking)    | An external subscriber is calling.<br>Press the key once to place the caller in the waiting field.  |

---

**Note:** If a caller is placed in the waiting field by pressing the waiting field key, the LED then lights up in yellow next to the key. If a caller is placed in the waiting field either automatically or by another waiting field reception, the LED then lights up in red.

---

The configuration can be carried out as follows:

- Via COMfortel Set
- Via the telephone menu

### **Configuring Function Key for External Waiting Field via COMfortel Set**

*Requirements:*

– An open configuration and the required PIN, if necessary

1. Open the page **Function keys > Assign function keys**.
2. Only available in installed extension modules: In the telephone displayed at the top left, click the key group in which you would like to define keys.
3. Click the **Level 1** tab.

---

**Important:** Configuring this function is only possible on the first level. The second level is then blocked. If a function has been assigned to the second level, it is deleted.

---

4. Right-click the function key you want to assign.  
A function selection dialogue opens.
5. Select the **Waiting field (external)** function.  
The current settings for defining the key are displayed.
6. Make the necessary changes depending on the type of PBX.
  - In the **B channel** list field, select the S<sub>0</sub> port with the corresponding B channel, whose incoming calls are to be monitored.

- In the **Telephone no** entry field, enter the telephone number for the bundle whose incoming calls should be monitored. The following entries are possible:

Up to 24 digits

---

**Note:** A bundle can be either an S<sub>0</sub> port, multiple bundled S<sub>0</sub>ports, an S<sub>2M</sub> port or a VoIP account.

---

7. In the **Key name** entry field, enter a name for the key. The following entries are possible:

Up to 16 digits

Digits and characters

Clicking  automatically enters the default name in the entry field.

---

**Note:** The key name is used for printing the label.

---

*Further steps:*

- *Save your configuration before closing.*

*Requirements for operating the function:*

- *The telephone has been selected in the PBX as a waiting field reception*

### **Configuring Function Key for External Waiting Field via Telephone Menu**

*Requirements:*

- *Knowledge of the telephone, its menu options and the required PIN, if necessary*

1. Press the **menu key** and open the **define keys** menu.
2. Press the **function key** that you would like to define.
3. Select **first level**.

---

**Important:** Configuring this function is only possible on the first level. The second level is then blocked. If a function has been assigned to the second level, it is deleted.

---

The list of available functions is displayed.

4. Select the **waiting field** function and then – depending of the type of PBX – select **external**.

The current settings for defining the key are shown on the display.

5. Press the  **softkey**.
6. Make the necessary changes depending on the type of PBX.
  - Select the S<sub>0</sub> port and then the B channel, whose incoming calls are to be monitored.
  - Select the bundle whose incoming calls should be monitored.

---

**Note:** A bundle can be either an S<sub>0</sub> port, multiple bundled S<sub>0</sub>ports, an S<sub>2M</sub> port or a VoIP account.

---

7. Press the  **softkey** to accept the setting.

*Requirements for operating the function:*

- *The telephone has been selected in the PBX as a waiting field reception*

---

## Configuring and Operating Function Key for Internal Waiting Field

---

**Important:** Only available for operation on the PBXs COMpact 5020 VoIP, COMmander Basic.2 and COMmander Business.

**Note:** A maximum of one internal waiting field key is possible on a single telephone.

---



Press the key to place the internal caller in the waiting field or establish a connection with the caller from the waiting field. Whether you press the key depends on the current status as displayed by the LED next to the key. Refer to the description of LED signalling.

**LED signalling next to the key:**

Green	<p>There is currently a connection with an internal subscriber. Information about the communication partner is shown on the display: (If other waiting field receptions have been enabled, the communication partners for these are not signalled.)</p> <p>Press the key once to place the communication partner in the waiting field.</p>
Yellow	<p>An internal subscriber is on hold in the waiting field. Information about the calls waiting are shown on the display: (If other waiting field receptions have been enabled, the calls waiting in these are not signalled.)</p> <p>Press the key once to establish a connection to the call waiting.</p>
Red	<p>An internal subscriber is on hold in the waiting field. (If other waiting field receptions have been enabled, the calls waiting in these are not signalled.)</p> <p>Press the key once to display information about the call waiting – if no call is in progress.</p>
Yellow (blinking)	<p>An internal subscriber is calling. Information about the caller is shown on the display:</p> <p>Press the key once to place the caller in the waiting field.</p> <p>Press the key twice to establish a connection to the caller.</p>
Red (blinking)	<p>An internal subscriber is calling.</p> <p>Press the key once to place the caller in the waiting field.</p>

The configuration can be carried out as follows:

- Via COMfortel Set
- Via the telephone menu

## **Configuring Function Key for Internal Waiting Field via COMfortel Set**

### *Requirements:*

- An open configuration and the required PIN, if necessary

1. Open the page **Function keys > Assign function keys**.
2. Only available in installed extension modules: In the telephone displayed at the top left, click the key group in which you would like to define keys.
3. Click the **Level 1** tab.

---

**Important:** Configuring this function is only possible on the first level. The second level is then blocked. If a function has been assigned to the second level, it is deleted.

---

4. Right-click the function key you want to assign.  
A function selection dialogue opens.
5. Select the **Waiting field (internal)** function.  
The current settings for defining the key are displayed.
6. In the **Key name** entry field, enter a name for the key. The following entries are possible:
  - Up to 16 digits
  - Digits and characters

Clicking  automatically enters the default name in the entry field.

---

**Note:** The key name is used for printing the label.

---

### *Further steps:*

- Save your configuration before closing.

### *Requirements for operating the function:*

- The telephone has been selected in the PBX as a waiting field reception

## **Configuring Function Key for Internal Waiting Field via Telephone Menu**

### *Requirements:*

– Knowledge of the telephone, its menu options and the required PIN, if necessary

1. Press the **menu key** and open the **define keys** menu.
2. Press the **function key** that you would like to define.
3. Select **first level**.

---

**Important:** Configuring this function is only possible on the first level. The second level is then blocked. If a function has been assigned to the second level, it is deleted.

---

The list of available functions is displayed.

4. Select the **waiting field** function and then **internal**.

The current settings for defining the key are shown on the display.

5. Press the **✓ softkey** to accept the setting.

### *Requirements for operating the function:*

– The telephone has been selected in the PBX as a waiting field reception

---

## **Configuring and Operating Function Key for Switching Waiting Field Reception On/Off**

Press the key while in the telephone's idle state to switch the waiting field reception on or off or switch it over.

In addition, the status of the function is indicated by the corresponding LED.

### **LED signalling next to the key:**

- |       |  |
|-------|--|
| Green | The waiting field reception is enabled.  |
| Off   | The waiting field reception is disabled. |

The configuration can be carried out as follows:

- Via COMfortel Set
- Via the telephone menu

### **Configuring Function Key for Switching Waiting Field Reception On/Off via COMfortel Set**

*Requirements:*

– An open configuration and the required PIN, if necessary

1. Open the page **Function keys > Assign function keys**.
2. Only available in installed extension modules: In the telephone displayed at the top left, click the key group in which you would like to define keys.
3. Click the **Level 1** tab.

---

**Important:** Configuring this function is only possible on the first level.

---

4. Right-click the function key you want to assign.  
A function selection dialogue opens.
5. Select the **Waiting field reception** function.  
The current settings for defining the key are displayed.
6. In the **Kind of switching** list field, select one of the following options:
  - switch off:** Disables the waiting field reception.
  - switch on:** Enables the waiting field reception.
  - switch over:** Press the key to switch the waiting field reception function on and off.
7. In the **Key name** entry field, enter a name for the key. The following entries are possible:
  - Up to 16 digits
  - Digits and characters

Clicking  automatically enters the default name in the entry field.

---

**Note:** The key name is used for printing the label.

---

*Further steps:*

- *Save your configuration before closing.*

*Requirements for operating the function:*

- *The telephone has been selected in the PBX as a waiting field reception*

### **Configuring Function Key for Switching Waiting Field Reception On/Off via Telephone Menu**

*Requirements:*

- *Knowledge of the telephone, its menu options and the required PIN, if necessary*

1. Press the **menu key** and open the **define keys** menu.
2. Press the **function key** that you would like to define.
3. Select **first level**.

---

**Important:** Configuring this function is only possible on the first level.

---

The list of available functions is displayed.

4. Select the **w fld.reception** function.

The current settings for defining the key are shown on the display.

5. Select the kind of switching. Press the  **softkey** to switch over between the different kinds of switching.

**switch off:** Disables the waiting field reception.

**switch on:** Enables the waiting field reception.

**switch over:** Press the key to switch the waiting field reception function on and off.

6. Press the  **softkey** to accept the setting.

*Requirements for operating the function:*

- *The telephone has been selected in the PBX as a waiting field reception*

## Switching Attention Tone for Waiting Field On/Off

If the attention tone has been switched on for the waiting field, incoming calls in the waiting field are signalled by an attention tone. If the attention tone bothers you, you can switch it off. The volume of the attention tone is dependent on the configured ringer volume.

Switching this on/off can be done as follows:

- Via COMfortel Set
- Via the telephone menu

### Switching Attention Tone for Waiting Field On/Off via COMfortel Set

*Requirements:*

– An open configuration and the required PIN, if necessary

1. Open the page **Settings/functions > Signalling/ringer**.
2. Select or clear the **Attention tone (waiting field)** check box.
  - Enables the attention tone for the waiting field.
  - Disables the attention tone for the waiting field.

*Further steps:*

– Save your configuration before closing.

### Switching Attention Tone for Waiting Field On/Off via Telephone Menu

*Requirements:*

– Knowledge of the telephone, its menu options and the required PIN, if necessary

1. Press the **menu key** and open the menu **settings > signalling > attention tone**.
2. Select or clear the **waiting field** check box.
  - Enables the attention tone for the waiting field.
  - Disables the attention tone for the waiting field.
3. Press the **✓ softkey** to accept the setting.

# Configuring and Operating the Answering Machine

This section describes how to set up and operate the functions on your answering machine. Descriptions are given on what the functions do, how to operate them and – if possible – how to define these functions on programmable function keys.

In most cases, configuration can be carried out in two different ways:

- Configuration via the telephone menu
- Configuration via COMfortel Set

---

**Note:** The answering machine function is only available on a COMfortel 2500 with an SD card. In addition, after 30 days, the COMfortel Voicemail function must be activated via the Upgrade Center. Instructions on how to commission and activate the answering machine are provided in the accompanying Commissioning Instructions.

---

## Topics

- [Forwarding Incoming Calls to Answering Machine \(page 368\)](#)
- [Answering Machine Accepts Call – Call Acceptance \(page 369\)](#)
- [Readiness \(page 370\)](#)
- [Answering Machine List \(page 374\)](#)
- [List of Voice Memos \(page 380\)](#)
- [Announcements \(page 385\)](#)
- [Call Acceptance and Announcement Assignment \(page 391\)](#)
- [Basic Settings \(page 415\)](#)
- [Call Recording \(page 422\)](#)
- [Remote Access \(page 430\)](#)
- [Message Forwarding \(page 438\)](#)
- [Data Exchange \(page 448\)](#)

# Forwarding Incoming Calls to Answering Machine

*Requirements:*

- *Knowledge of the telephone and its menu options*
- *Disabled readiness of the answering machine*

When you receive a call, proceed as described in the following.

1. Select **answer. machine**.
2. Press the **✓ softkey**.

The answering machine accepts the call.



# Answering Machine Accepts Call – Call Acceptance

*Requirements:*

- *Knowledge of the telephone and its menu options*

---

**Note:** If the listen in function has been enabled on the answering machine, the loudspeaker on the telephone is switched on for listening in when a call is accepted by the answering machine.

---

If the answering machine has already accepted the call, proceed as described.

- Pick up the receiver or press the **Hook key**.

You are connected with the caller.

# Readiness

In order for the answering machine to accept calls and record messages, readiness must be enabled.

---

## Switching Readiness On/Off

---

### Note:

Also when readiness is enabled, only calls of the types that have been activated for call acceptance will be accepted.

You can also switch readiness on and off remotely.

---

Switching this on/off can be done as follows:

- Via COMfortel Set
- Via the telephone menu

### Switching Readiness On/Off via COMfortel Set

#### *Requirements:*

- An answering machine, put into operation
- An open configuration and the required PIN, if necessary

1. Open the page **Answering machine > Global**.
2. Select or clear the **Answering machine readiness** check box.
  - Enables the readiness function.
  - Disables the readiness function.

#### *Further steps:*



- Save your configuration before closing.

## Switching Readiness On/Off via Telephone Menu

### *Requirements:*

- An answering machine, put into operation
- Knowledge of the telephone, its menu options and the required PIN, if necessary

In order to switch readiness on or off, press the **function key** configured for readiness.

In addition, you can enable readiness from the idle state by pressing the  **softkey**, and disable it by pressing the  **softkey**. The icon indicates the current state.

Or, proceed as described in the following.

1. Press the **menu key** and open the menu **answer.machine > functions > TAM readiness**.

The  icon indicates the current setting.

2. Select the desired option:

**switch on:** Enables readiness.

**switch off:** Disables readiness.

---

## Configuring and Operating Function Key for Readiness

Press the key to switch readiness on or off or to switch it over.

In addition, when functions are defined on the first key level, the status of the function is indicated by the corresponding LED.

### **LED signalling next to the key:**

Green            The readiness function is enabled.

Off                The readiness function is disabled.

The configuration can be carried out as follows:

- Via COMfortel Set
- Via the telephone menu

## **Configuring Function Key for Readiness via COMfortel Set**

### *Requirements:*

- An answering machine, put into operation
- An open configuration and the required PIN, if necessary

1. Open the page **Function keys > Assign function keys**.
2. Only available in installed extension modules: In the telephone displayed at the top left, click the key group in which you would like to define keys.
3. Click one of the following tabs:
  - Level 1:** Keys are defined on the first key level.
  - Level 2:** Keys are defined on the second key level.
4. Right-click the function key you want to assign.  
A function selection dialogue opens.
5. Select the **Answering machine - readiness** function.  
The current settings for defining the key are displayed.
6. In the **Kind of switching** list field, select one of the following options:
  - switch off:** Press the key to disable the readiness function.
  - switch on:** Press the key to enable the readiness function.
  - switch over:** Press the key to switch the readiness function on and off.
7. In the **Key name** entry field, enter a name for the key. The following entries are possible:
  - Up to 16 digits
  - Digits and characters

Clicking  automatically enters the default name in the entry field.

---

**Note:** The key name is used for printing the label.

---



### *Further steps:*

- Save your configuration before closing.

## **Configuring Function Key for Readiness via Telephone Menu**

### *Requirements:*

- *An answering machine, put into operation*
- *Knowledge of the telephone, its menu options and the required PIN, if necessary*

1. Press the **menu key** and open the **define keys** menu.
2. Press the **function key** that you would like to define.
3. Select the desired option:
  - first level:** Keys are defined on the first key level.
  - second level:** Keys are defined on the second key level.The list of available functions is displayed.
4. Select the **TAM readiness** function.  
The current settings for defining the key are shown on the display.
5. Select the kind of switching. Press the  **softkey** to switch over between the different kinds of switching.
  - switch off:** Press the key to disable the readiness function.
  - switch on:** Press the key to enable the readiness function.
  - switch over:** Press the key to switch the readiness function on and off.
6. Press the  **softkey** to accept the setting.

## Answering Machine List

The telephone answering machine list can save up to 250 messages and call recordings made on the answering machine. The list also includes the date and time of the recording as well as the telephone number of the caller/communication partner. The recordings are numbered consecutively, with the last/latest recording assigned the number 1.

You can call someone who has called you directly from the answering machine list.

The LED above the message key indicates whether entries are present on the answering machine list.

---

### Opening the Answering Machine List

Opening can be carried out as follows:

- Via the telephone menu

#### *Requirements:*

- *An answering machine, put into operation*
- *Knowledge of the telephone, its menu options and the required PIN, if necessary*

To open the answering machine list, press the **function key** configured for it or press the **menu key** to open the menu **answer.machine > functions > TAM list**.

Or, proceed as described in the following.

1. Press the **message key**.

The available lists are displayed. To the right next to the selection of lists, the respective number of existing recordings/calls is displayed.

2. Select **TAM list** to open the answering machine list (this is skipped if the other lists are empty).

The following information about the recording is shown on the display:

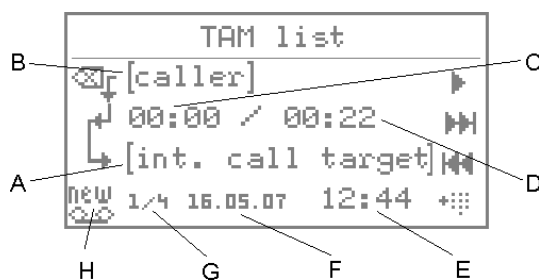

- A Internal call target
- B Caller
- C Length of time the recording has been played back
- D Entire length of the recording
- E Time of recording
- F Date of recording
- G Consecutive number of recordings/number of existing recordings

---

**Note:** The latest recording is displayed with consecutive number 1.

---

- H Recording type: new message (<sup>new</sup>), older message already played back (<sup>old</sup>), call recording (☒).

---

**Note:** If you have activated automatic playback, the new recordings are automatically played back in sequence after the answering machine list is opened. The latest recording is played back first.

---

3. Select the desired option:

- ☒ Deletes the displayed recording.
- ▶ Starts the playback of the recording.
- ▶▶ Pages to the next (older) recording.
- ◀◀ Pages to the previous (more recent) recording.
- ⋮ Accepts the entry into dial preparation or into the telephone book, if applicable.

4. If you would like to leave the menu, press the **Exit key**.

---

## Listening to recordings (messages and call recordings)

Listening can be carried out as follows:

- Via the telephone menu

### *Requirements:*

- An answering machine, put into operation
- Knowledge of the telephone, its menu options and the required PIN, if necessary

1. Open the answering machine list.
2. Use the **▶▶** and **◀◀** **softkeys** to scroll to the desired recording.
3. Press the **▶** **softkey** to start playing back the recording.

---

**Note:** You can also pick up the receiver to prevent others present from listening.

---

The recording is played back.

4. Select the desired option:
  - ☒ Deletes the recording currently being played back.
  - || Interrupts playback.
  - ▶▶ Skips the recording currently being played back.
  - ◀◀ Repeats the previous recording or the one currently being played back.
  - \*# Accepts the entry into dial preparation or into the telephone book, if applicable.
5. If you would like to leave the menu, press the **Exit key**.

---

**Note:** You can also access and listen to the recordings remotely.

---



## Dialling from the Answering Machine List

*Requirements:*

- *An answering machine, put into operation*
- *Knowledge of the telephone, its menu options and the required PIN, if necessary*

1. Open the answering machine list.
2. Use the **▶▶** and **◀◀** **softkeys** to scroll to the desired recording.
3. Press the **\*#** **softkey** in order to accept the telephone number in dial preparation.
4. Pick up the receiver or press the **Hook key**.

The subscriber is called.

---

**Note:** If you would like to exit the menu without dialling the number displayed, press the **Exit key**.

---

---

## Configuring the LED Message Key

**See:**

- [Configuring the LED Message Key \(page 143\)](#)

---

## Configuring and Operating Function Key for Answering Machine List

Press the key while the telephone is in the idle state to open the answering machine list.

In addition, when functions are defined on the first key level, the status of the answering machine list is indicated by the corresponding LED.

**LED signalling next to the key:**

Green	There are no new entries. All of the entries in the list have been viewed, but have not yet been deleted.
Green (blinking)	The list contains new entries that have not yet been viewed.
Off	The list is empty.

The configuration can be carried out as follows:

- Via COMfortel Set
- Via the telephone menu

**Configuring Function Key for Answering Machine List via COMfortel Set**

*Requirements:*

- An answering machine, put into operation
- An open configuration and the required PIN, if necessary

1. Open the page **Function keys > Assign function keys**.
2. Only available in installed extension modules: In the telephone displayed at the top left, click the key group in which you would like to define keys.
3. Click one of the following tabs:
  - Level 1:** Keys are defined on the first key level.
  - Level 2:** Keys are defined on the second key level.
4. Right-click the function key you want to assign.  
A function selection dialogue opens.
5. Select the **Answering machine - list** function.  
The current settings for defining the key are displayed.

6. In the **Key name** entry field, enter a name for the key. The following entries are possible:

Up to 16 digits

Digits and characters

Clicking  automatically enters the default name in the entry field.

---

**Note:** The key name is used for printing the label.

---

*Further steps:*

- *Save your configuration before closing.*

### **Configuring Function Key for Answering Machine List via Telephone Menu**

*Requirements:*

- *An answering machine, put into operation*
- *Knowledge of the telephone, its menu options and the required PIN, if necessary*

1. Press the **menu key** and open the **define keys** menu.
2. Press the **function key** that you would like to define.
3. Select the desired option:
  - first level:** Keys are defined on the first key level.
  - second level:** Keys are defined on the second key level.The list of available functions is displayed.
4. Select the **TAM list** function.
5. Press the  **softkey** to accept the setting.

## List of Voice Memos

Up to 250 voice memos including date, time, and length of the recording can be saved in this list. The recordings are numbered consecutively, with the last/latest recording assigned the number 1.

The LED above the message key indicates entries in the voice memo list.

---

### Recording Memos

The recording can be made as follows:

- Via the telephone menu

#### *Requirements:*

- *An answering machine, put into operation*
- *Knowledge of the telephone, its menu options and the required PIN, if necessary*

To record voice memos, press a **function key** configured for recording voice memos.

Or, proceed as described in the following.

1. Press the **menu key** and open the menu **answer.machine > functions > TAM voice memo**.
2. Press the **✓ softkey** next to **start of record**. to start the recording.  
The recording proceeds.
3. Record the memo.
4. Press the **✓ softkey** next to **end of recording** to end the recording.
5. Press the **✓ softkey** to save the recording.

---

**Note:** Recordings with a recording time shorter than 1 second are discarded by the telephone.

---

## Configuring and Operating Function Key Recording Voice Memos

Press the key while the telephone is in the idle state to start recording a voice memo.

In addition, when functions are defined on the first key level, the associated LED indicates whether a voice memo is currently being recorded.

### LED signalling next to the key:

Red (blinking) A voice memo is being recorded.

The configuration can be carried out as follows:

- Via COMfortel Set
- Via the telephone menu

### Configuring Function Key for Recording Voice Memos via COMfortel Set

#### *Requirements:*

- An answering machine, put into operation
- An open configuration and the required PIN, if necessary

1. Open the page **Function keys > Assign function keys**.
2. Only available in installed extension modules: In the telephone displayed at the top left, click the key group in which you would like to define keys.
3. Click one of the following tabs:
  - Level 1:** Keys are defined on the first key level.
  - Level 2:** Keys are defined on the second key level.
4. Right-click the function key you want to assign.  
A function selection dialogue opens.
5. Select the **Answering machine - voice memo** function.  
The current settings for defining the key are displayed.
6. In the **Key name** entry field, enter a name for the key. The following entries are possible:
  - Up to 16 digits
  - Digits and characters

Clicking  automatically enters the default name in the entry field.

---

**Note:** The key name is used for printing the label.

---

*Further steps:*

- *Save your configuration before closing.*

### **Configuring Function Key for Recording Voice Memos via Telephone Menu**

*Requirements:*

- *An answering machine, put into operation*
- *Knowledge of the telephone, its menu options and the required PIN, if necessary*

1. Press the **menu key** and open the **define keys** menu.
2. Press the **function key** that you would like to define.
3. Select the desired option:
  - first level:** Keys are defined on the first key level.
  - second level:** Keys are defined on the second key level.

The list of available functions is displayed.

4. Select the **TAM voice memo** function.
5. Press the **✓ softkey** to accept the setting.

---

### **Opening the List of Voice Memos**

Opening can be carried out as follows:

- Via the telephone menu

**Requirements:**

- An answering machine, put into operation
- Knowledge of the telephone, its menu options and the required PIN, if necessary



1. Press the **message key**.

The available lists are displayed. To the right next to the selection of lists, the respective numbers of existing recordings and calls are displayed.

2. Select **TAM voice memos** to open the list of voice memos (this is skipped if the other lists are empty).

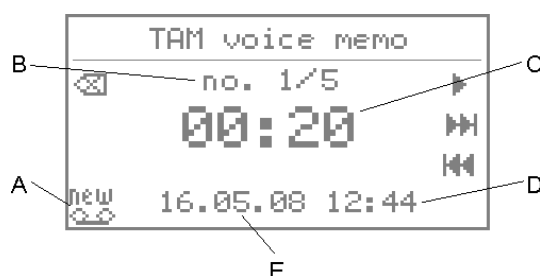
The following information about the recording is shown on the display:



A Recording type: new voice memo () , old voice memo already listens to () .

B Consecutive number of recording/number of existing recordings

---

**Note:** The latest recording is displayed with consecutive number 1.

---

C Length of the recording

D Time of recording





E Date of recording

---

**Note:** If you have activated automatic playback, the new recordings are automatically played back in sequence after the list of voice memos is opened. The latest recording is played back first.

---

3. Select the desired option:

-  Deletes the displayed recording.
-  Starts the playback of the recording.
-  Pages to next (older) recording.
-  Pages to the previous (more recent) recording.

4. If you would like to leave the menu, press the **Exit key**.

## Listening to Recordings (Memos)

Listening can be carried out as follows:

- Via the telephone menu

### *Requirements:*

- *An answering machine, put into operation*
- *Knowledge of the telephone, its menu options and the required PIN, if necessary*

1. Open the voice memo list.
2. Use the **▶▶** and **◀◀** **softkeys** to scroll to the desired recording.
3. Press the **▶** **softkey** to start playing back the recording.

---

**Note:** You can also pick-up the receiver to prevent others present from listening.

---

The recording is played back.

4. Select the desired option:
  - ◻ Deletes the recording currently being played back.
  - || Interrupts playback.
  - ▶▶ Skips the recording currently being played back.
  - ◀◀ Repeats the previous recording or the one currently being played back.
5. If you would like to leave the menu, press the **Exit key**.

---

## Configuring the LED Message Key

### **See:**

- [Configuring the LED Message Key \(page 143\)](#)



# Announcements

In addition to standard announcements, the answering machine lets you manage customized announcements.

Existing announcements can be transferred to a SD card via COMfortel Set or new announcements can be recorded over the phone.

The announcements can be assigned to different types of calls as well as to different callers.

---

## Creating a New Announcement

The creation can be carried out as follows:

- Via the telephone menu

### *Requirements:*

- An answering machine, put into operation
- Knowledge of the telephone, its menu options and the required PIN, if necessary

1. Press the **menu key** and open the menu **answer.machine > settings > edit announcem..**
2. Press the **☐ softkey** in front of **new announcement** to record a new announcement (this step is skipped if there are not yet any announcements).
3. Enter the name. The following entries are possible:
  - Up to 8 digits
  - Numbers and characters using the 0...9 keys
4. Press the **✓ softkey** to save the entry.
5. Press the **✓ softkey** next to **start of record.** to start recording the announcement.  
The recording proceeds.
6. Record the announcement.
7. Press the **✓ softkey** next to **end of recording** to end recording the announcement.

---

**Note:**

You have the option of recording the announcement again (by selecting **new announcement** option) or listening to the announcement that you recorded (by selecting the **playback** option).

Recordings with a recording time shorter than 1 second are discarded by the telephone.

---

8. Select **store** to save the recorded announcement in the announcement list.

---

## Editing Existing Announcement in List

Editing can be carried out as follows:



- Via the telephone menu



*Requirements:*

- An answering machine, put into operation
- Knowledge of the telephone, its menu options and the required PIN, if necessary

In order to edit an announcement, press the **function key** configured for editing announcements.

Or, proceed as described in the following.

1. Press the **menu key** and open the menu **answer.machine > settings > edit announcem..**
2. Scroll to the desired entry.
3. Press the  **softkey**.
4. Select **change**.
5. Overwrite the name, if necessary. The following entries are possible:
  - Up to 8 digits
  - Digits and characters
6. Press the  **softkey** to save the entry.

7. Press the  **softkey** to overwrite the existing announcement.
8. Press the  **softkey** next to **start of record.** to start recording the announcement.  
The recording proceeds.
9. Record the announcement.
10. Press the  **softkey** next to **end of recording** to end recording the announcement.

---

**Note:**

You have the option of recording the announcement again (by selecting **new announcement** option) or listening to the announcement that you recorded (by selecting the **playback** option).

Recordings with a recording time shorter than 1 second are discarded by the telephone.

---

11. Select **store** to save the recorded announcement in the announcement list.

---

## Deleting an Existing Announcement from List

Deleting can be carried out as follows:



- Via the telephone menu

*Requirements:*

- An answering machine, put into operation
- Knowledge of the telephone, its menu options and the required PIN, if necessary

In order to delete an announcement, press the **function key** configured.

Or, proceed as described in the following.

1. Press the **menu key** and open the menu **answer.machine > settings > edit announcem..**
2. Scroll to the desired entry.
3. Press the  **softkey**.
4. Select **delete**.
5. Press the  **softkey** to confirm the action.

---

## Configuring and Operating Function Key for Editing Announcements

Press the key for general functions while the telephone is in the idle state to open the announcement selection menu. After selecting an announcement, you can edit it.

While the telephone is in the idle state, press the key defined for opening the menu for editing the configured announcement.

### LED signalling next to the key:

None

The configuration can be carried out as follows:

- Via COMfortel Set
- Via the telephone menu

### Configuring Function Key for Editing Announcements via COMfortel Set

#### *Requirements:*

- An answering machine, put into operation
- An open configuration and the required PIN, if necessary

1. Open the page **Function keys > Assign function keys**.
2. Only available in installed extension modules: In the telephone displayed at the top left, click the key group in which you would like to define keys.
3. Click one of the following tabs:
  - Level 1:** Keys are defined on the first key level.
  - Level 2:** Keys are defined on the second key level.
4. Right-click the function key you want to assign.  
A function selection dialogue opens.
5. Select the **Answering machine - edit announcement** function.  
The current settings for defining the key are displayed.
6. In the **Key name** entry field, enter a name for the key. The following entries are possible:
  - Up to 16 digits
  - Digits and characters

Clicking  automatically enters the default name in the entry field.

---

**Note:** The key name is used for printing the label.

---

*Further steps:*

- *Save your configuration before closing.*

### **Configuring Function Key for Editing a Defined Announcement via COMfortel Set**

*Requirements:*

- *An answering machine, put into operation*
- *An open configuration and the required PIN, if necessary*

1. Open the page **Function keys > Assign function keys**.
2. Only available in installed extension modules: In the telephone displayed at the top left, click the key group in which you would like to define keys.
3. Click one of the following tabs:
  - Level 1:** Keys are defined on the first key level.
  - Level 2:** Keys are defined on the second key level.
4. Right-click the function key you want to assign.  
A function selection dialogue opens.
5. Select the **Answering machine - edit announcement defined**.  
The current settings for defining the key are displayed.
6. Select an announcement from the **Announcement** list.  
If you would like to select an announcement that is stored on the telephone SD card, but is not listed as a selection in the list field, click . The announcements are read from the SD card and then displayed in the list field.
7. In the **Key name** entry field, enter a name for the key. The following entries are possible:
  - Up to 16 digits
  - Digits and characters

Clicking  automatically enters the default name in the entry field.

---

**Note:** The key name is used for printing the label.

---

*Further steps:*

- *Save your configuration before closing.*

### **Configuring Function Key for Editing Announcements via Telephone Menu**

*Requirements:*

- *An answering machine, put into operation*
- *Knowledge of the telephone, its menu options and the required PIN, if necessary*

1. Press the **menu key** and open the **define keys** menu.
2. Press the **function key** that you would like to define.
3. Select the desired option from the list.

**first level:** Keys are defined on the first key level.

**second level:** Keys are defined on the second key level.

The list of available functions is displayed.



4. Select the **TAM edit announc** function.

The current settings for defining the key are shown on the display.

5. Select the kind of key. Press the  **softkey** to switch over between the different kinds of keys.

**general:** Press the key to open the menu for selecting an assignment from the list. (No other action is required.)

**defined:** Press the key to open the menu for editing the configured announcement.

6. Press the  **softkey**.
7. Select an announcement from the list.
8. Press the  **softkey** to accept the setting.

# Call Acceptance and Announcement Assignment

Call acceptance and announcement assignment can be configured to be both call-dependent and time-dependent.

---

## Configuration Variants for Call Acceptance and Announcement Assignment

The following configuration variants are possible for call acceptance and announcement assignment:

### Simple Automatic

For each of the six types of calls, anonymous calls, calls for groups, external calls, internal calls, door terminal calls and call deblocker calls, separate call acceptance and announcement assignment can be configured.

### Automatic for Experts

In addition to the six types of calls for the simple automatic function, calls for specific group telephone numbers, calls for specific separate external telephone numbers as well as calls for specific door numbers can be differentiated.

For each of these types of calls, multiple entries for call acceptance and announcement assignment can be created. These entries can be activated manually by pressing a key and/or time-dependently.

### Special Call Acceptance/Announcement for Telephone Book Contacts

For each contact entered in the telephone book, special settings for call acceptance and announcement can be configured. In order to ensure that these settings are used, the special call acceptance/announcement for all of the telephone book contacts must be activated.

## Call Types

The type of call acceptance can be configured depending on the type of call. The two following call types are differentiated by whether they focus on the caller or on the call target.

- A Calls from a telephone book contact** (caller transmits a telephone number contained in the telephone book)
- B Anonymous calls** (caller transmits no telephone number)
- C Call deblocker calls** (when do-not-disturb is switched on, caller transmits a telephone number contained in the call deblocker)
- D Calls for group telephone number X** (call target is a specific group number)
- E Calls for the subscriber's own external telephone number X** (call target is a specific external telephone number for the subscriber)
- F Calls for groups** (call target is any group number)
- G External calls** (caller is an external subscriber)
- H Internal calls** (caller is an internal subscriber)
- I Door terminal calls for door number X** (caller is a specific door terminal)
- J Door terminal calls** (caller is any door terminal)

The sequence displayed here corresponds to the sequence that is taken into account in the settings. Applicable call types, for which no settings (default) have been configured, are not taken into account for an incoming call. Instead, the next applicable call type is sought out. If a setting has not been made for any of the applicable call types, the default setting **Announcement and recording** with the default announcement STANDARD.WAV is used.

### Example

The following example illustrates taking the settings into account:

#### Initial situation

- Different settings have been made regarding call acceptance and announcement for internal calls (call type **H**) and external calls (call type **G**) as well as for calls to your group telephone number 300 (call type **D**).
- The answering machine is switched on.



## Call 1

Properties of call 1:

- The caller is an external subscriber who does not transmit a telephone number.
- The call target is the external telephone number assigned to the internal subscriber telephone number.

Sequence for call 1:

- The call type **A** does not apply due to the missing telephone number display.
- For the first applicable call type **B**, no setting are present.
- The call type **C** does not apply due to the missing telephone number display.
- The call types **D**, **E** and **F** do not apply due to the telephone number dialled.
- The existing setting for the next applicable call type **G** is used.

## Call 2

Properties of call 2:

- The caller is a door terminal.

Sequence for call 2:

- The call types **A** to **H** are not taken into account for door terminal calls.
- Not setting is present for call types **I** and **J**.
- The default setting **Announcement and recording** with the default announcement STANDARD.WAV is used.

---

## Configuring Simple Automatic

The configuration can be carried out as follows:

- Via COMfortel Set
- Via the telephone menu

## Configuring Simple Automatic via COMfortel Set

### *Requirements:*

- An answering machine, put into operation
- An open configuration and the required PIN, if necessary

1. Open the page **Answering machine > Automatic**.
2. Click the **Standard** tab.
3. If an entry should be activated together with other entries simultaneously at the press of a key, select the desired collective ID for the entry of the call type in question from the **Collective ID** entry field. The following entries are possible:

**80 to 99**

4. In the **Call acceptance** list field, select one of the following options for the call type in question.

**Standard:** Type of call is not taken into account. The type of call acceptance depends on the call type next applicable to the call. If **Standard** has been selected for all the applicable call types, the caller hears the default announcement and can then leave a message on the answering machine.

**Announcement and recording:** The caller hears the announcement selected under **Announcement** and can then leave a message on the answering machine.

**Only announcement:** The caller hears the announcement selected under **Announcement**; however, he cannot leave a message on the answering machine.

**No call acceptance:** The call made by the corresponding caller is not accepted by the answering machine.

5. In the **Announcement** list field, select the desired announcement for the call type in question.

If you would like to select an announcement on the telephone SD card, but is not listed as a selection in the list field, click . The announcements are read from the SD card and then displayed in the list field.

### *Further steps:*

- Save your configuration before closing.

## Configuring Function Key for Simple Automatic via Telephone Menu

### *Requirements:*

- *An answering machine, put into operation*
- *Knowledge of the telephone, its menu options and the required PIN, if necessary*

1. Press the **menu key** and open the menu **answer.machine > functions > TAM announcement**.
2. Select the type of call for which you would like to configure call acceptance.  
The ● icon indicates the current setting.
3. Select one of the following options for the call type in question.
  - standard:** Type of call is not taken into account. The type of call acceptance depends on the call type which is applicable to the call next. If **standard** has been selected for all the applicable call types, the caller hears the default announcement and can then leave a message on the answering machine.
  - announc/record.:** At the end, the caller hears the selected announcement and can then leave a message on the answering machine.
  - announcem.only:** At the end, the caller hears the selected announcement; however, he cannot leave a message on the answering machine.
  - no call accept.:** The call made by the corresponding caller is not accepted by the answering machine.
4. Scroll through the announcement list to your selection.  
The name of the announcement along with the creation date and time is displayed.
5. Press the ✓ **softkey** to accept the setting.

---

## Configuring Automatic for Experts

The configuration can be carried out as follows:

- Via COMfortel Set

### *Requirements:*

- *An answering machine, put into operation*
- *An open configuration and the required PIN, if necessary*

1. Open the page **Answering machine > Automatic**.
2. Select or clear the **Expert view** check box
  - Enables the expert view.
3. Select or clear the **Time control** check box.
  - Enables time control.
  - Disables time control.

---

**Note:** Time control can be enabled or disabled as needed via the telephone menu or a function key.

---

4. Create entries for the various types of calls in the automatic as described in the following.

---

**Note:**

If no entry has been created for a type of call, the setting for the simple automatic applies to this type of call.

In order to ensure that time-dependent entries are taken into account, time control must also be enabled for the entry in question.

---

5. In order to be able to manually activate an entry by pressing a key, configure a function key with the ID assigned to the entry as described in the following.

---

**Note:** If more than one entry should be activated simultaneously with a key, assign the entries in question to a collective ID and configure a function key with the collective ID saved on it.

---

*Further steps:*

- *Save your configuration before closing.*

## Creating Entries for Automatic

The creation can be carried out as follows:

- Via COMfortel Set

### Creating Entry in Automatic for Anonymous Calls

*Requirements:*

- An answering machine, put into operation
- An open configuration and the required PIN, if necessary

1. Open the page **Answering machine > Automatic**.
2. Click the **Anonymous calls** tab.
3. Select one of the following options:

**Depending on configuration:** A configuration can be defined for each entry in which the configuration for the entry is taken into account in the PBX.

**Individual switching times:** An individual switching time can be configured for each entry according to the weekday and time. The entry is then taken into account starting at this switching point up to the next valid switching point.

---

**Note:** This setting or the **Depending on configuration** option is only available for operation on the PBXs COMmander Business, COMmander Basic.2, COMpact 3000, COMpact 5020 VoIP and COMpact 5010 VoIP.

---

4. In the **ID** entry field, enter an ID for the entry. The following entries are possible:  
**10 to 79**

---

**Note:** An ID may only be issued once.

---

5. If this entry should be activated together with other entries simultaneously at the press of a key, select the desired collective ID for the entry from the **Collective ID** entry field. The following entries are possible:

**80 to 99**

6. In the **Call acceptance** list field, select one of the following options:

**Announcement and recording:** The caller hears the announcement selected under **Announcement** and can then leave a message on the answering machine.

**Only announcement:** The caller hears the announcement selected under **Announcement**; however, he cannot leave a message on the answering machine.

**No call acceptance:** The call made by the corresponding caller is not accepted by the answering machine.

7. Select the desired announcement in the **Announcement** list field.

If you would like to select an announcement that is stored on the telephone SD card, but is not listed as a selection in the list field, click . The announcements are read from the SD card and then displayed in the list field.

8. Select or clear the **Time control active** check box.

- Time control is enabled for the entry in question.
- Time control is disabled for the entry in question. (No other action is required.)

9. Configure the settings for time control dependent on the type of time control.

- In the **Configuration** entry field, enter the identification number of the PBX configuration.
- In the **Day** list field, select the desired day or days on which the entry should automatically be activated. In the **Time** entry field, enter the associated time.

*Further steps:*

- *Save your configuration before closing.*

### **Creating Entry in Automatic for Calls for Groups**

*Requirements:*

- *An answering machine, put into operation*
- *An open configuration and the required PIN, if necessary*

1. Open the page **Answering machine > Automatic**.
2. Click the **Calls for groups** tab.

3. Select one of the following options:

**Depending on configuration:** A configuration can be defined for each entry in which the configuration for the entry is taken into account in the PBX.

**Individual switching times:** An individual switching time can be configured for each entry according to the weekday and time. The entry is then taken into account starting at this switching point up to the next valid switching point.

---

**Note:** This setting or the **Depending on configuration** option is only available for operation on the PBXs COMmander Business, COMmander Basic.2, COMpact 3000, COMpact 5020 VoIP and COMpact 5010 VoIP.

---

4. In the **ID** entry field, enter an ID for the entry. The following entries are possible:

**10 to 79**

---

**Note:** An ID may only be issued once.

---

5. If this entry should be activated together with other entries simultaneously at the press of a key, select the desired collective ID for the entry from the **Collective ID** entry field. The following entries are possible:

**80 to 99**

6. In the **Group telephone number** entry field, enter the group telephone number that applies to the entry in question.

---

**Note:**

If no group telephone number has been entered, the entry in question applies to all calls for groups.

If you have already entered group phone numbers under **Settings > Defined signalization**, these will also be listed. To do this, double-click the field in question. A list field opens in which you can select the desired group phone numbers.

---

7. In the **Call acceptance** list field, select one of the following options:

**Announcement and recording:** The caller hears the announcement selected under **Announcement** and can then leave a message on the answering machine.

**Only announcement:** The caller hears the announcement selected under **Announcement**; however, he cannot leave a message on the answering machine.

**No call acceptance:** The call made by the corresponding caller is not accepted by the answering machine.

8. Select the desired announcement in the **Announcement** list field.

If you would like to select an announcement that is stored on the telephone SD card, but is not listed as a selection in the list field, click . The announcements are read from the SD card and then displayed in the list field.

9. Select or clear the **Time control active** check box.

- Time control is enabled for the entry in question.
- Time control is disabled for the entry in question. (No other action is required.)

10. Configure the settings for time control dependent on the type of time control.

- In the **Configuration** entry field, enter the identification number of the PBX configuration.
- In the **Day** list field, select the desired day or days on which the entry should automatically be activated. In the **Time** entry field, enter the associated time.

*Further steps:*

- *Save your configuration before closing.*

### **Creating an Entry in Automatic for External Calls**

*Requirements:*

- *An answering machine, put into operation*
- *An open configuration and the required PIN, if necessary*

1. Open the page **Answering machine > Automatic**.
2. Click the **External calls** tab.



3. Select one of the following options:

**Depending on configuration:** A configuration can be defined for each entry in which the configuration for the entry is taken into account in the PBX.

**Individual switching times:** An individual switching time can be configured for each entry according to the weekday and time. The entry is then taken into account starting at this switching point up to the next valid switching point.

---

**Note:** This setting or the **Depending on configuration** option is only available for operation on the PBXs COMmander Business, COMmander Basic.2, COMpact 3000, COMpact 5020 VoIP and COMpact 5010 VoIP.

---

4. In the **ID** entry field, enter an ID for the entry. The following entries are possible:

**10 to 79**

---

**Note:** An ID may only be issued once.

---

5. If this entry should be activated together with other entries simultaneously at the press of a key, select the desired collective ID for the entry from the **Collective ID** entry field. The following entries are possible:

**80 to 99**

6. In the **External telephone number** entry field, enter one of your own external telephone numbers to which the entry in question should apply.

---

**Note:**

If no external telephone number is entered here, the entry in question applies to all external calls.

If you have already entered external telephone numbers under **Settings > Defined signalization**, these will also be listed. To do this, double-click the field in question. A list field opens in which you can select the desired external telephone numbers.

---

7. In the **Call acceptance** list field, select one of the following options:

**Announcement and recording:** The caller hears the announcement selected under **Announcement** and can then leave a message on the answering machine.

**Only announcement:** The caller hears the announcement selected under **Announcement**; however, he cannot leave a message on the answering machine.

**No call acceptance:** The call made by the corresponding caller is not accepted by the answering machine.

8. Select the desired announcement in the **Announcement** list field.

If you would like to select an announcement that is stored on the telephone SD card, but is not listed as a selection in the list field, click . The announcements are read from the SD card and then displayed in the list field.

9. Select or clear the **Time control active** check box.

- Time control is enabled for the entry in question.
- Time control is disabled for the entry in question. (No other action is required.)

10. Configure the settings for time control dependent on the type of time control.

- In the **Configuration** entry field, enter the identification number of the PBX configuration.
- In the **Day** list field, select the desired day or days on which the entry should automatically be activated. In the **Time** entry field, enter the associated time.

*Further steps:*

- *Save your configuration before closing.*

### **Creating an Entry in Automatic for Internal Calls**

*Requirements:*

- *An answering machine, put into operation*
- *An open configuration and the required PIN, if necessary*

1. Open the page **Answering machine > Automatic**.
2. Click the **Internal calls** tab.

3. Select one of the following options:

**Depending on configuration:** A configuration can be defined for each entry in which the configuration for the entry is taken into account in the PBX.

**Individual switching times:** An individual switching time can be configured for each entry according to the weekday and time. The entry is then taken into account starting at this switching point up to the next valid switching point.

---

**Note:** This setting or the **Depending on configuration** option is only available for operation on the PBXs COMmander Business, COMmander Basic.2, COMpact 3000, COMpact 5020 VoIP and COMpact 5010 VoIP.

---

4. In the **ID** entry field, enter an ID for the entry. The following entries are possible:

**10 to 79**

---

**Note:** An ID may only be issued once.

---

5. If this entry should be activated together with other entries simultaneously at the press of a key, select the desired collective ID for the entry from the **Collective ID** entry field. The following entries are possible:

**80 to 99**

6. In the **Call acceptance** list field, select one of the following options:

**Announcement and recording:** The caller hears the announcement selected under **Announcement** and can then leave a message on the answering machine.

**Only announcement:** The caller hears the announcement selected under **Announcement**; however, he cannot leave a message on the answering machine.

**No call acceptance:** The call made by the corresponding caller is not accepted by the answering machine.

7. Select the desired announcement in the **Announcement** list field.

If you would like to select an announcement that is stored on the telephone SD card, but is not listed as a selection in the list field, click . The announcements are read from the SD card and then displayed in the list field.

8. Select or clear the **Time control active** check box.

Time control is enabled for the entry in question.

Time control is disabled for the entry in question. (No other action is required.)

9. Configure the settings for time control dependent on the type of time control.

- In the **Configuration** entry field, enter the identification number of the PBX configuration.
- In the **Day** list field, select the desired day or days on which the entry should automatically be activated. In the **Time** entry field, enter the associated time.

*Further steps:*

- *Save your configuration before closing.*

### **Creating an Entry in Automatic for Door Terminal Calls**

*Requirements:*

- *An answering machine, put into operation*
- *An open configuration and the required PIN, if necessary*

1. Open the page **Answering machine > Automatic**.
2. Click the **Door terminal calls** tab.
3. Select one of the following options:

**Depending on configuration:** A configuration can be defined for each entry in which the configuration for the entry is taken into account in the PBX.

**Individual switching times:** An individual switching time can be configured for each entry according to the weekday and time. The entry is then taken into account starting at this switching point up to the next valid switching point.

---

**Note:** This setting or the **Depending on configuration** option is only available for operation on the PBXs COMmander Business, COMmander Basic.2, COMpact 3000, COMpact 5020 VoIP and COMpact 5010 VoIP.

---

4. In the **ID** entry field, enter an ID for the entry. The following entries are possible:

**10 bis 79**

---

**Note:** An ID may only be issued once.

---

5. If this entry should be activated together with other entries simultaneously at the press of a key, enter an ID for the entry in the **Collective ID** entry field. The following entries are possible:

**80 bis 99**

6. In the **Door number** entry field, enter the door number that applies to the entry in question.

---

**Note:** If no door number has been entered here, the entry in question applies to all door terminal calls.

---

7. In the **Call acceptance** list field, select one of the following options:

**Announcement and recording:** The caller hears the announcement selected under **Announcement** and can then leave a message on the answering machine.

**Only announcement:** The caller hears the announcement selected under **Announcement**; however, he cannot leave a message on the answering machine.

**No call acceptance:** The call made by the corresponding caller is not accepted by the answering machine.

8. Select the desired announcement in the **Announcement** list field.

If you would like to select an announcement on the telephone SD card, but is not listed as a selection in the list field, click . The announcements are read from the SD card and then displayed in the list field.

9. Select or clear the **Time control active** check box.

- Time control is enabled for the entry in question.
- Time control is disabled for the entry in question. (No other action is required.)

10. Configure the settings for time control dependent on the type of time control.

- In the **Configuration** entry field, enter the ID of the PBX configuration.
- In the **Day** list field, select the desired day or days on which the entry should automatically be activated. In the **Time** entry field, enter the associated time.

*Further steps:*

- *Save your configuration before closing.*

### **Creating an Entry in Automatic for Call Deblocker Calls**

*Requirements:*

- *An answering machine, put into operation*
- *An open configuration and the required PIN, if necessary*

1. Open the page **Answering machine > Automatic**.
2. Click the **Call Deblocker calls** tab.
3. Select one of the following options:

**Depending on configuration:** A configuration can be defined for each entry in which the configuration for the entry is taken into account in the PBX.

**Individual switching times:** An individual switching time can be configured for each entry according to the weekday and time. The entry is then taken into account starting at this switching point up to the next valid switching point.

---

**Note:** This setting or the **Depending on configuration** option is only available for operation on the PBXs COMmander Business, COMmander Basic.2, COMpact 3000, COMpact 5020 VoIP and COMpact 5010 VoIP.

---

4. In the **ID** entry field, enter an ID for the entry. The following entries are possible:

**10 to 79**

---

**Note:** An ID may only be issued once.

---

5. If this entry should be activated together with other entries simultaneously at the press of a key, select the desired collective ID for the entry from the **Collective ID** entry field. The following entries are possible:

**80 to 99**

6. In the **Call acceptance** list field, select one of the following options:

**Announcement and recording:** The caller hears the announcement selected under **Announcement** and can then leave a message on the answering machine.

**Only announcement:** The caller hears the announcement selected under **Announcement**; however, he cannot leave a message on the answering machine.

**No call acceptance:** The call made by the corresponding caller is not accepted by the answering machine.

7. Select the desired announcement in the **Announcement** list field.

If you would like to select an announcement that is stored on the telephone SD card, but is not listed as a selection in the list field, click . The announcements are read from the SD card and then displayed in the list field.

8. Select or clear the **Time control active** check box.
  - Time control is enabled for the entry in question.
  - Time control is disabled for the entry in question. (No other action is required.)
9. Configure the settings for time control dependent on the type of time control.
  - In the **Configuration** entry field, enter the identification number of the PBX configuration.
  - In the **Day** list field, select the desired day or days on which the entry should automatically be activated. In the **Time** entry field, enter the associated time.

*Further steps:*

- *Save your configuration before closing.*

---

## Deleting Entries in Automatic

Deleting can be carried out as follows:

- Via COMfortel Set

*Requirements:*

- *An answering machine, put into operation*
- *An open configuration and the required PIN, if necessary*

1. Open the page **Answering machine > Automatic**.
2. Click the tab for the type of call desired.
3. Right-click the network connection to be deleted.

In order to delete multiple entries at the same time, hold the left mouse button down and drag your mouse over the entries to be deleted.

4. Click **Delete**.

*Further steps:*

- *Save your configuration before closing.*

---

## Configuring and Operating Function Key for Manually Activating Entries in Automatic

While the telephone is in the idle state, press the key defined for opening the menu for entering an automatic ID. After this, you can activate entry associated with the automatic ID.

While the telephone is in the idle state, press the key defined for activating the entry associated with the configured automatic ID.

In addition, when functions are defined on the first key level, the status of the function is indicated by the corresponding LED.

### LED signalling next to the key (only for defined key assignment):

Green	The entry associated with the automatic ID saved on the key is active.
Off	The entry associated with the automatic ID saved on the key is not active.

The configuration can be carried out as follows:

- Via COMfortel Set
- Via the telephone menu

## Configuring Function Key for Manually Activating Entries in Automatic via COMfortel Set

### *Requirements:*

- An answering machine, put into operation
- An open configuration and the required PIN, if necessary

1. Open the page **Function keys > Assign function keys**.
2. Only available in installed extension modules: In the telephone displayed at the top left, click the key group in which you would like to define keys.
3. Click one of the following tabs:
  - Level 1:** Keys are defined on the first key level.
  - Level 2:** Keys are defined on the second key level.
4. Right-click the function key you want to assign.  
A function selection dialogue opens.
5. Select the **Answering machine - automatic ID** function.



The current settings for defining the key are displayed.

6. In the **Key name** entry field, enter a name for the key. The following entries are possible:

Up to 16 digits

Digits and characters

Clicking  automatically enters the default name in the entry field.

---

**Note:** The key name is used for printing the label.

---

*Further steps:*

- *Save your configuration before closing.*

### **Configuring Function Key for Manually Activating a Defined Entry in Automatic via COMfortel Set**

*Requirements:*

- *An answering machine, put into operation*
- *An open configuration and the required PIN, if necessary*

1. Open the page **Function keys > Assign function keys**.
2. Only available in installed extension modules: In the telephone displayed at the top left, click the key group in which you would like to define keys.
3. Click one of the following tabs:
  - Level 1:** Keys are defined on the first key level.
  - Level 2:** Keys are defined on the second key level.
4. Right-click the function key you want to assign.  
A function selection dialogue opens.
5. Select the **Answering machine - automatic ID defined** function.  
The current settings for defining the key are displayed.
6. In the **Automatic ID** entry field, enter an ID from the automatic table.

7. In the **Key name** entry field, enter a name for the key. The following entries are possible:

Up to 16 digits

Digits and characters

Clicking  automatically enters the default name in the entry field.

---

**Note:** The key name is used for printing the label and for display.

---

*Further steps:*

- *Save your configuration before closing.*

## **Configuring Function Key for Manually Activating Entries in Automatic via Telephone Menu**

*Requirements:*

- *An answering machine, put into operation*
- *Knowledge of the telephone, its menu options and the required PIN, if necessary*

1. Press the **menu key** and open the **define keys** menu.
2. Press the **function key** that you would like to define.
3. Select the desired option from the list.

**first level:** Keys are defined on the first key level.

**second level:** Keys are defined on the second key level.

The list of available functions is displayed.



4. Select the **TAM automatic ID** function.

The current settings for defining the key are shown on the display.

5. Select the kind of key. Press the  **softkey** to switch over between the different kinds of keys.

**general:** Press the key to open the menu for entering an ID. (No other action is required.)

**defined:** Press the key to open the menu for activating the configured ID.

6. Press the  **softkey**.
7. Enter an ID from the automatic table.
8. Press the  **softkey**.
9. Enter a name. The following entries are possible:
  - Up to 16 digits
  - Digits and characters
10. Press the  **softkey** to accept the setting.

---

## Switching Time Control On/Off

If time control has been enabled, the time control configured for call acceptance and announcement assignment in COMfortel Set is used.

---

**Note:** If you switch off time control, all entries active at this point in time remain. Manual changes are still possible.

---

Switching this on/off can be done as follows:

- Via COMfortel Set
- Via the telephone menu

### Switching Time Control On/Off via COMfortel Set

*Requirements:*

- An answering machine, put into operation
- An open configuration and the required PIN, if necessary

1. Open the page **Answering machine > Automatic**.
2. Select or clear the **Time control** check box.
  - Enables time control.
  - Disables time control.

*Further steps:*

- Save your configuration before closing.

## **Switching Time Control On/Off via Telephone Menu**

### *Requirements:*

- *An answering machine, put into operation*
- *Knowledge of the telephone, its menu options and the required PIN, if necessary*

In order to switch time control on or off, press the **function key** configured for time control.

Or, proceed as described in the following.

1. Press the **menu key** and open the menu **answer.machine > functions > TAM time control**.

The ● icon indicates the current setting.

2. Select the desired option:

**switch on:** Enables time control.

**switch off:** Disables time control.

---

## **Configuring and Operating Function Key for Time Control**

Press the key to switch the time control function on or off or to switch it over.

In addition, when functions are defined on the first key level, the status of the function is indicated by the corresponding LED.

### **LED signalling next to the key:**

Green	Time control is enabled.
Off	Time control is disabled.

The configuration can be carried out as follows:

- Via COMfortel Set
- Via the telephone menu

## **Configuring Function Key for Time Control via COMfortel Set**

### *Requirements:*

- An answering machine, put into operation
- An open configuration and the required PIN, if necessary

1. Open the page **Function keys > Assign function keys**.
2. Only available in installed extension modules: In the telephone displayed at the top left, click the key group in which you would like to define keys.
3. Click one of the following tabs:
  - Level 1:** Keys are defined on the first key level.
  - Level 2:** Keys are defined on the second key level.
4. Right-click the function key you want to assign.  
A function selection dialogue opens.
5. Select the **Answering machine - time control** function.  
The current settings for defining the key are displayed.
6. In the **Kind of switching** list field, select one of the following options:
  - switch off:** Press the key to disable time control.
  - switch on:** Press the key to enable time control.
  - switch over:** Press the key to switch time control on and off.
7. In the **Key name** entry field, enter a name for the key. The following entries are possible:
  - Up to 16 digits
  - Digits and characters

Clicking  automatically enters the default name in the entry field.

---

**Note:** The key name is used for printing the label.

---



### *Further steps:*

- Save your configuration before closing.

## **Configuring Function Key for Time Control via Telephone Menu**

### *Requirements:*

- *An answering machine, put into operation*
- *Knowledge of the telephone, its menu options and the required PIN, if necessary*

1. Press the **menu key** and open the **define keys** menu.
2. Press the **function key** that you would like to define.
3. Select the desired option:
  - first level:** Keys are defined on the first key level.
  - second level:** Keys are defined on the second key level.The list of available functions is displayed.
4. Select the **TAM time control** function.  
The current settings for defining the key are shown on the display.
5. Select the kind of switching. Pressing the  **softkey** allows you to switch over between the different kinds of switching.
  - switch off:** Press the key to disable time control.
  - switch on:** Press the key to enable time control.
  - switch over:** Press the key to switch time control on and off.
6. Press the  **softkey** to accept the setting.

## Basic Settings

Default settings have already been configured for the basic functions on the answering machine. These basic functions can be adapted to your own specific requirements as described in the following.

---

### Configuring Call Acceptance Time

The call acceptance time indicates the number of seconds after which the answering machine accepts a call.

The configuration can be made as follows:

- Via COMfortel Set
- Via the telephone menu

#### Configuring Call Acceptance Time via COMfortel Set

*Requirements:*

- An answering machine, put into operation
- An open configuration and the required PIN, if necessary

1. Open the page **Answering machine > Global**.
2. Enter a value in the **Call acceptance time (1-99 seconds)** entry field. The following entries are possible:
  - 1 to 99:** The answering machine accepts the call, depending on the entry, after 1 to 99 minutes.

*Further steps:*

- *Save your configuration before closing.*

## Configuring Call Acceptance Time via Telephone Menu

### *Requirements:*

- *An answering machine, put into operation*
- *Knowledge of the telephone, its menu options and the required PIN, if necessary*

1. Press the **menu key** and open the menu **answer.machine > settings > call accept time**.
2. Enter a value. The following entries are possible:
  - 1 to 99:** The answering machine accepts the call, depending on the entry, after 1 to 99 seconds.
3. Press the **✓ softkey** to save the entry.

---

**Note:** If you have enabled the remote access toll saver, the call accept time depends on whether new messages are present or not.

---

---

## **Configuring Maximum Recording Time**

The maximum recording time indicates the number of minutes after which the answering machine ends a recording automatically (in as far as the caller has not already hung up).

The configuration can be made as follows:

- Via COMfortel Set
- Via the telephone menu

## Configuring Maximum Recording Time via COMfortel Set

### *Requirements:*

- *An answering machine, put into operation*
- *An open configuration and the required PIN, if necessary*

1. Open the page **Answering machine > Global**.



2. Enter a value in the entry field **Recording time general (in minutes, 99 = max. storage utilization)**. The following entries are possible:

**0:** No recording takes place. The caller hears only an announcement.

**1 to 98:** The maximum recording time is configured (1 to 98 minutes).

**99:** The recording time is unlimited (maximum storage utilization).

---

**Note:** Recordings with a recording time shorter than 1 second are discarded by the telephone.

---

*Further steps:*

- *Save your configuration before closing.*

### **Configuring Maximum Recording Time via Telephone Menu**

*Requirements:*

- *An answering machine, put into operation*
- *Knowledge of the telephone, its menu options and the required PIN, if necessary*

1. Press the **menu key** and open the menu **answer.machine > settings > recording time**.
2. Enter a value. The following entries are possible:
  - 0:** No recording takes place. The caller hears only an announcement.
  - 1 to 98:** The maximum recording time is configured (1 to 98 minutes).
  - 99:** The recording time is unlimited (maximum storage utilization).
3. Press the **✓ softkey** to save the entry.

---

**Note:** Recordings with a recording time shorter than 1 second are discarded by the telephone.

---

## **Configuring Maximum Recording Time for Door Terminal Calls**

The maximum recording time for door terminal calls indicates the number of minutes after which the answering machine ends the recording of a door terminal call automatically.

Note that the recording cannot be actively ended from the door terminal. Therefore, a door terminal call recording lasts as long as you have defined it.

The configuration can be made as follows:

- Via COMfortel Set
- Via the telephone menu

### **Configuring Maximum Recording Time for Door Terminal Calls via COMfortel Set**

*Requirements:*

- An answering machine, put into operation
- An open configuration and the required PIN, if necessary

1. Open the page **Answering machine > Global**.
2. Enter a value in the **Recording time door (in minutes)** entry field. The following entries are possible:
  - 0**: No recording takes place. The caller hears only an announcement.
  - 1 to 98**: The maximum recording time is configured (1 to 98 minutes).
  - 99**: The recording time is unlimited (maximum storage utilization).

*Further steps:*

- Save your configuration before closing.

### **Configuring Maximum Recording Time for Door Terminal Calls via Telephone Menu**

*Requirements:*

- An answering machine, put into operation
- Knowledge of the telephone, its menu options and the required PIN, if necessary

1. Press the **menu key** and open the menu **answer.machine > settings > record. time door**.

2. Enter a value. The following entries are possible:
  - 0:** No recording takes place. The caller hears only an announcement.
  - 1 to 98:** The maximum recording time is configured (1 to 98 minutes).
  - 99:** The recording time is unlimited (maximum storage utilization).
3. Press the  **softkey** to save the entry.

---

## Switching Listen in Function On/Off

If the listen in function is enabled, the loudspeaker on the telephone is switched on for listening in when a call is accepted by the answering machine. Depending on whether to listen to your own announcement every time or not, it can also be configured if the loudspeaker on the telephone is switched on or off during playback of the announcement.

Switching this on/off can be done as follows:

- Via COMfortel Set
- Via the telephone menu

### Switching Listen in Function On/Off via COMfortel Set

*Requirements:*

- An answering machine, put into operation
- An open configuration and the required PIN, if necessary

1. Open the page **Answering machine > Global**.
2. In the **Listen in** list field, select one of the following options:
  - off:** Disables the listen in function.
  - with announcement:** Enables the listen in function. The loudspeaker on the telephone is switched on during playback of the announcement.
  - without announcement:** Enables the listen in function. The loudspeaker on the telephone is switched off during playback of the announcement.

*Further steps:*

- Save your configuration before closing.

## Switching Listen in Function On/Off via Telephone Menu

### *Requirements:*

- *An answering machine, put into operation*
- *Knowledge of the telephone, its menu options and the required PIN, if necessary*

1. Press the **menu key** and open the menu **answer.machine > settings > listen in**.  
The ● icon indicates the current setting.

2. Select the desired option:

**off:** Disables the listen in function.

**with announcem.:** Enables the listen in function. The loudspeaker on the telephone is switched on during playback of the announcement.

**w/o announcement:** Enables the listen in function. The loudspeaker on the telephone is switched off during playback of the announcement.

---

## **Switching Automatic Playback On/Off**

If automatic playback is enabled, the new recordings are played back automatically after the answering machine list or the voice memo list is open.

Switching this on/off can be done as follows:

- Via COMfortel Set
- Via the telephone menu

## Switching Automatic Playback On/Off via COMfortel Set

### *Requirements:*

- *An answering machine, put into operation*
- *An open configuration and the required PIN, if necessary*

1. Open the page **Answering machine > Global**.

2. Select or clear the **Automatic playback of all recordings** check box.
  - Enables automatic playback.
  - Disables automatic playback.

---

**Note:** Call recordings are excluded from automatic playback.

---

*Further steps:*

- *Save your configuration before closing.*

### **Switching Automatic Playback On/Off via Telephone Menu**

*Requirements:*

- *An answering machine, put into operation*
- *Knowledge of the telephone, its menu options and the required PIN, if necessary*

1. Press the **menu key** and open the menu **answer.machine > settings > autom. playback**.
2. Select or clear the **autom. playback** check box.
  - Enables automatic playback.
  - Disables automatic playback.
3. Press the **✓ softkey** to accept the setting.

# Call Recording

The call recording function enables telephone calls to be recorded, for example, for later evaluation. In addition to the automatic recording of all calls, it is also possible to record calls manually. This functions independent of the automatic call recording function. This allows calls to be recorded in pieces.

---

## Executing Call Recording

If automatic call recording is enabled, every call you make it automatically recorded.

---

**Note:** Always ask your communication partner to give his approval for recording the call. You are liable to prosecution, if you record a call without your communication partner's knowledge (breach of confidentiality of the word). For reasons of data protection, an info tone informs your communication partner that the call is being recorded.

---

### *Requirements:*

- *An answering machine, put into operation*
- *Knowledge of the telephone, its menu options and the required PIN, if necessary*

To start or end recording during a call, press the **function key** configured for initiating call recording.

Or, during a call, proceed as described in the following.

1. Select the **TAM call record.** function.
2. Press the **✓ softkey** to start call recording.  
The call is recorded.
3. Press the **✓ softkey** to end call recording.

---

**Note:** Recordings with a recording time shorter than 1 second are discarded by the telephone.

---

---

## Configuring and Operating Function Key for Call Recording Initiation On/Off

Press the key during a call to switch call recording on. Press the key again to turn it off.

In addition, when functions are defined on the first key level, the status of the function is indicated by the corresponding LED.

### LED signalling next to the key:

Red (blinking) The current call is recorded.

The configuration can be carried out as follows:

- Via COMfortel Set
- Via the telephone menu

### Configuring Function Key for Call Recording Initiation via COMfortel Set

#### *Requirements:*

- An answering machine, put into operation
- An open configuration and the required PIN, if necessary

1. Open the page **Function keys > Assign function keys**.
2. Only available in installed extension modules: In the telephone displayed at the top left, click the key group in which you would like to define keys.
3. Click one of the following tabs:
  - Level 1:** Keys are defined on the first key level.
  - Level 2:** Keys are defined on the second key level.
4. Right-click the function key you want to assign.  
A function selection dialogue opens.
5. Select the **Answering machine - call recording** function.  
The current settings for defining the key are displayed.
6. In the **Key name** entry field, enter a name for the key. The following entries are possible:
  - Up to 16 digits
  - Digits and characters

Clicking  automatically enters the default name in the entry field.

---

**Note:** The key name is used for printing the label.

---

*Further steps:*

- *Save your configuration before closing.*

### **Configuring Function Key for Call Recording Initiation via Telephone Menu**

*Requirements:*

- *An answering machine, put into operation*
- *Knowledge of the telephone, its menu options and the required PIN, if necessary*

1. Press the **menu key** and open the **define keys** menu.
2. Press the **function key** that you would like to define.
3. Select the desired option:
  - first level:** Keys are defined on the first key level.
  - second level:** Keys are defined on the second key level.

The list of available functions is displayed.

4. Select the **TAM call record.** function.
5. Press the **✓ softkey** to accept the setting.



## Switching Automatic Call Recording On/Off

If automatic call recording has been enabled, every call (incoming and outgoing) is recorded completely.

---

### Note:

Always ask your communication partner to give his approval for recording the call. You are liable to prosecution, if you record a call without your communication partner's knowledge (breach of confidentiality of the word). For reasons of data protection, an info tone informs your communication partner that the call is being recorded.

Recordings with a recording time shorter than 1 second are discarded by the telephone.

---

Switching this on/off can be done as follows:

- Via COMfortel Set
- Via the telephone menu

### Switching Automatic Call Recording On/Off via COMfortel Set

#### *Requirements:*

- An answering machine, put into operation
- An open configuration and the required PIN, if necessary

1. Open the page **Answering machine > Global**.
2. Select or clear the **Automatic call recording** check box.
  - Enables automatic call recording.
  - Disables automatic call recording.

#### *Further steps:*

- Save your configuration before closing.

## **Switching Automatic Call Recording On/Off via Telephone Menu**

### *Requirements:*

- *An answering machine, put into operation*
- *Knowledge of the telephone, its menu options and the required PIN, if necessary*

Press the **function Key** configured for automatic call recording to switch automatic call recording on or off.

Or, proceed as described in the following.

1. Press the **menu key** and open the menu **answer.machine > functions > TAM aut.call rec.**

The ● icon indicates the current setting.

2. Select the desired option:

**switch on:** Enables automatic call recording.

**switch off:** Disables automatic call recording.

---

## **Configuring and Operating Function Key for Automatic Call Recording**

Press the key to switch the automatic call recording function on or off or to switch it over.

In addition, when functions are defined on the first key level, the status of the function is indicated by the corresponding LED.

### **LED signalling next to the key:**

Red            Automatic call recording is enabled.

Red (blinking) The current call is recorded.

(Signalling only occurs here if automatic call recording enabled; not, however, if call recording is enabled during a call.)

Off            Automatic call recording is disabled.

The configuration can be carried out as follows:

- Via COMfortel Set
- Via the telephone menu

## **Configuring Function Key for Automatic Call Recording via COMfortel Set**

### *Requirements:*

- An answering machine, put into operation
- An open configuration and the required PIN, if necessary

1. Open the page **Function keys > Assign function keys**.
2. Only available in installed extension modules: In the telephone displayed at the top left, click the key group in which you would like to define keys.
3. Click one of the following tabs:
  - Level 1:** Keys are defined on the first key level.
  - Level 2:** Keys are defined on the second key level.
4. Right-click the function key you want to assign.  
A function selection dialogue opens.
5. Select the **Answering machine - automatic call recording** function.  
The current settings for defining the key are displayed.
6. In the **Kind of switching** list field, select one of the following options:
  - switch off:** Press the key to disable automatic call recording.
  - switch on:** Press the key to enable automatic call recording.
  - switch over:** Press the key to switch automatic call recording over.
7. In the **Key name** entry field, enter a name for the key. The following entries are possible:
  - Up to 16 digits
  - Digits and characters

Clicking  automatically enters the default name in the entry field.

---

**Note:** The key name is used for printing the label.

---



### *Further steps:*

- Save your configuration before closing.

## **Configuring Function Key for Automatic Call Recording via Telephone Menu**

### *Requirements:*

- *An answering machine, put into operation*
- *Knowledge of the telephone, its menu options and the required PIN, if necessary*

1. Press the **menu key** and open the **define keys** menu.
2. Press the **function key** that you would like to define.
3. Select the desired option:
  - first level:** Keys are defined on the first key level.
  - second level:** Keys are defined on the second key level.The list of available functions is displayed.
4. Select the **TAM aut.call rec** function.  
The current settings for defining the key are shown on the display.
5. Select the kind of switching. Press the  **softkey** to switch over between the different kinds of switching.
  - switch off:** Press the key to disable automatic call recording.
  - switch on:** Press the key to enable automatic call recording.
  - switch over:** Press the key to switch automatic call recording over.
6. Press the  **softkey** to accept the setting.

---

## **Switching Info Tone for Call Recording On/Off**

In order to notify your communication partner that the call is being recorded, you can switch on the call recording info tone.

---

**Note:** Always ask your communication partner to give his approval for recording the call. You are liable to prosecution, if you record a call without your communication partner's knowledge (breach of confidentiality of the word).

---

Switching this on/off can be done as follows:

- Via COMfortel Set
- Via the telephone menu

### **Switching Info Tone for Call Recording On/Off via COMfortel Set**

*Requirements:*

- An answering machine, put into operation
- An open configuration and the required PIN, if necessary

1. Open the page **Answering machine > Global**.
2. Select or clear the **Info tone call recording** check box.
  - Enables the call recording info tone.
  - Disables the call recording info tone.

*Further steps:*

- Save your configuration before closing.

### **Switching Info Tone for Call Recording On/Off via Telephone Menu**

*Requirements:*

- An answering machine, put into operation
- Knowledge of the telephone, its menu options and the required PIN, if necessary

1. Press the **menu key** and open the menu **answer.machine > settings > call rec.tone**.
2. Select or clear the **call rec.tone** check box.
  - Enables the call recording info tone.
  - Disables the call recording info tone.
3. Press the **✓ softkey** to accept the setting.

# Remote Access

Remote access is used to access and operate the answering machine from another internal telephone or from an external telephone.

---

## Remote Access Variants

The answering machine supports three different remote access variants:

### Remote access toll saver off

The answering machine always accepts a call after the call accept time configured.

After the answering machine has accepted the call, you can initiate remote access during the announcement and the following 10 seconds (by pressing the \* key + user PIN + # key).

### Remote access toll saver on

The answering machine only accepts a call after the call accept time configured if there are new messages present. Otherwise, if no new messages are present, the time it takes to accept a call is 10 seconds (approx. 2 rings) longer than the configured call accept time.

This notifies you before the answering machine accepts the call whether access is necessary or you can hang up.

After the answering machine has accepted the call, you can initiate remote access during the announcement and the following 10 seconds (by pressing the \* key + user PIN + # key).

---

#### Note:

Note that when remote access toll saver is enabled, the call accept time extended by 10 seconds applies to each caller (at least as long as there are no new messages present). Take this into consideration when configuring the call accept time.

If you have configured settings on your PBX or telephone that cause the telephone to delay making a call (for example, call forwarding on no reply for subscribers), using remote access toll saver is not meaningful.

---

## Remote Access Toll Saver with Quick Access

The answering machine automatically accepts a call when the quick remote access number is transmitted and new messages are present. Otherwise, if no new messages are present, the time it takes to accept a call is 10 seconds (approx. 2 rings) longer than the configured call accept time.

As soon as the answering machine has accepted the call, you can start remote access. Entering the user PIN is not necessary.

---

### Note:

When quick access is enabled, the call accept time varies only if the quick remote access number has been correctly transmitted. For all other callers, the answering machine accepts the call after the configured call accept time (independently of whether new messages are present or not).

If you have configured settings on your PBX or telephone that cause the telephone to delay making a call (for example, call forwarding on no reply for subscribers), using quick access is not meaningful.

---

---

## Configuring Remote Access

Remote access is configured as described in the following.

- Switch remote access on.
- Assign a user PIN.
- If you would like to save money by not using remote access, you can switch the remote access toll saver on as long as no new messages are present.
- If you would like to simplify remote access by not entering a user PIN and instead using your telephone number, switch the remote access toll saver with quick access on. In addition, enter one or two quick access telephone numbers.
- If you would like the answering machine to notify you as soon as new message is present, configure message forwarding and switch it on when required.

## Switching Remote Access On/Off

Switching this on/off can be done as follows:

- Via COMfortel Set
- Via the telephone menu

### Switching Remote Access On/Off via COMfortel Set

*Requirements:*

- An answering machine, put into operation
- An open configuration and the required PIN, if necessary

1. Open the page **Answering machine > Remote access**.
2. Select or clear the **Remote access** check box.
  - Enables remote access.
  - Disables remote access.

*Further steps:*

- Save your configuration before closing.

### Switching Remote Access On/Off via Telephone Menu

*Requirements:*

- An answering machine, put into operation
- Knowledge of the telephone, its menu options and the required PIN, if necessary

1. Press the **menu key** and open the menu **answer.machine > settings > remote access**.
2. Select or clear the **remote access** check box.
  - Enables remote access.
  - Disables remote access.
3. Press the **✓ softkey** to accept the setting.



## Switching Remote Access Toll Saver (and Quick Access) On/Off

Switching this on/off can be done as follows:

- Via COMfortel Set
- Via the telephone menu

### Switching Remote Access Toll Saver On/Off via COMfortel Set

*Requirements:*

- An answering machine, put into operation
- An open configuration and the required PIN, if necessary

1. Open the page **Answering machine > Remote access**.
2. In the **Remote access toll saver** list field, select one of the following options:
  - off:** Disables remote access toll saver.
  - on:** Enables remote access toll saver.
  - Quick remote access:** Enables remote access toll saver with quick access. Also requires entering a quick remote access number.

*Further steps:*

- Save your configuration before closing.

### Switching Remote Access Toll Saver On/Off via Telephone Menu

*Requirements:*

- An answering machine, put into operation
- Knowledge of the telephone, its menu options and the required PIN, if necessary

1. Press the **menu key** and open the menu **answer.machine > settings > r/a toll saver**.

The ● icon indicates the current setting.

2. Select the desired option:

**off:** Disables remote access toll saver.

**on:** Enables remote access toll saver.

**quick access:** Enables remote access toll saver with quick access. Also requires entering a quick remote access number.

---

## Entering Quick Access Telephone Numbers

For remote access toll saver with quick access, up to two quick access telephone numbers can be entered. The caller who transmits this quick remote access number when making a call can, when quick access is configured, access all of the recordings saved on the answering machine without having to enter the user PIN.

The entry can be made as follows:

- Via COMfortel Set
- Via the telephone menu

### Configuring Quick Access Telephone Numbers via COMfortel Set

*Requirements:*

- An answering machine, put into operation
- An open configuration and the required PIN, if necessary

1. Open the page **Answering machine > Remote access**.
2. In each of the entry fields **Quick remote access number 1** and **Quick remote access number 2**, enter a quick remote access number. The following entries are possible:

Up to 20 digits

Digits and the characters \* and #

---

**Note:** Click  to accept a telephone number from the telephone book.

---

3. In each of the list fields **Quick remote access number 1** and **Quick remote access number 2**, select one of the following options:

**Internal no.:** Defines the quick remote access number entered as an internal telephone number.

**External no.:** Defines the quick remote access number entered as an external telephone number.

*Further steps:*

- *Save your configuration before closing.*

### **Entering Quick Access Telephone Numbers via Telephone Menu**

*Requirements:*

- *An answering machine, put into operation*
- *Knowledge of the telephone, its menu options and the required PIN, if necessary*

1. Press the **menu key** and open the menu **answer.machine > settings > quick access**.
2. Select the desired option:
  - : Allows a quick remote access number to be entered.
  - [telephone number]**: Allows existing quick remote access numbers to be changed.

---

**Note:** If you press the **Telephone book key** before entering the quick remote access number, you can select the desired telephone number from the telephone book.

---

3. Enter the quick remote access number. The following entries are possible:
  - Up to 24 digits
  - Digits and the characters \* and #

---

**Important:** Enter telephone numbers exactly as when dialling, for example, always enter external telephone numbers with a leading exchange line access number. (exception: direct exchange access). The default exchange line access number on the PBX is "0" in the factory settings; however, this can be changed for several PBXs (see the PBX manual).

---

4. Press the **✓ softkey** to save the entry.

## Executing Remote Access

### Requirements:

- Configured remote access
- DTMF dialling support on the internal or external telephone
- Knowledge of the user PIN on the system telephone
- When readiness on the answering has been switched off: Configured remote access toll saver with quick remote access and transmission of a quick remote access number entered in advance by the telephone making the call

1. Call the system telephone.

After the configured call accept time has elapsed, the answering telephone accepts the call. You hear the configured announcement.

---

**Note:** When remote access toll saver is enabled, the call accept time may change. When remote access toll saver with quick remote access has been enabled, you also immediately hear the announcement for remote access (REMOTE.WAV). You can begin remote access (without PIN entry).

---

2. Initiate remote access during the announcement and the following 10 seconds by entering the following DTMF code: \* user PIN #

---

### Note:

If you make a mistake while entering the user PIN, you can reenter it after pressing the star key (\*).

When the entry is correct, you will hear a positive confirmation tone (6 short tones). If the entry is incorrect, you will hear a negative confirmation tone (3 long tones).

---

You then hear the announcement for remote access REMOTE.WAV.

3. Execute remote access by entering the following codes.
  - 2: Plays back new recordings (only messages).
  - 3: Plays back all recordings (call recordings and messages).
  - 4: Jumps back to the previous recording.
  - 5: Repeats the recording currently being played back.
  - 6: Jumps to the next recording.
  - 7: Deletes the recording currently being played back.

**8:** Ends playback.

**# automatic ID:** Enables the entry of the automatic function.

**\* 10:** Disables readiness.

**\* 11:** Enables readiness.

**\* 20:** Disables time control for the automatic function.

**\* 21:** Enables time control for the automatic function.

**\* 30:** Disables message forwarding.

**\* 31:** Enables message forwarding.

**\* 32 telephone number #:** Changes the destination for message forwarding.

**\* 70:** Deletes all of the recordings.

**\* 99:** Ends remote access and records a voice memo. After this, hang up the receiver.

**Hang-up:** Ends remote access.

# Message Forwarding

Message forwarding enables the answering machine to notify you of new messages even if you are out and about.

---

## Message Forwarding Sequence

Message forwarding proceeds as follows:

- When a caller leaves a new message, the telephone dials the destination number entered after the waiting time has elapsed.
- If the person receiving the call picks up the receiver, first the announcement and then the new message are played back.
- Remote access can be started within 30 seconds after the new messages have been played back.

---

## Switching Message Forwarding On/Off

If message forwarding has been configured, it can be enabled, for example, for times when you leave the building.

---

**Note:** You can also switch message forwarding on and off or enter a new destination number by remote access.

---

Switching this on/off can be done as follows:

- Via COMfortel Set
- Via the telephone menu

### **Switching Message Forwarding On/Off via COMfortel Set**

*Requirements:*

- An answering machine, put into operation
- An open configuration and the required PIN, if necessary

1. Open the page **Answering machine > Message forwarding**.
2. Select or clear the **Message forwarding** check box.
  - Enables message forwarding.
  - Disables message forwarding.

*Further steps:*

- Save your configuration before closing.

### **Switching Message Forwarding On/Off via Telephone Menu**

*Requirements:*

- An answering machine, put into operation
- Knowledge of the telephone, its menu options and the required PIN, if necessary

In order to switch message forwarding on or off, press the **function key** configured for message forwarding.

Or, proceed as described in the following.

1. Press the **menu key** and open the menu **answer.machine > functions > TAM message fwd.**  
The ● icon indicates the current setting.
2. Select the desired option:
  - switch on:** Enables message forwarding.
  - switch off:** Disables message forwarding.

## Configuring and Operating Function Key for Message Forwarding

Press the key to switch message forwarding on or off or to switch it over.

In addition, when functions are defined on the first key level, the status of the function is indicated by the corresponding LED.

### LED signalling next to the key:

Green	Message forwarding is enabled.
Off	Message forwarding is disabled.

The configuration can be carried out as follows:

- Via COMfortel Set
- Via the telephone menu

### Configuring Function Key Message Forwarding via COMfortel Set

#### *Requirements:*

- An answering machine, put into operation
- An open configuration and the required PIN, if necessary

1. Open the page **Function keys > Assign function keys**.
2. Only available in installed extension modules: In the telephone displayed at the top left, click the key group in which you would like to define keys.
3. Click one of the following tabs:
  - Level 1:** Keys are defined on the first key level.
  - Level 2:** Keys are defined on the second key level.
4. Right-click the function key you want to assign.  
A function selection dialogue opens.
5. Select the **Answering machine - message forwarding** function.  
The current settings for defining the key are displayed.



6. In the **Kind of switching** list field, select one of the following options:
  - switch off:** Press the key to disable message forwarding.
  - switch on:** Press the key to enable message forwarding.
  - switch over:** Press the key to switch message forwarding on and off.
7. In the **Key name** entry field, enter a name for the key. The following entries are possible:
  - Up to 16 digits
  - Digits and characters

Clicking  automatically enters the default name in the entry field.

---

**Note:** The key name is used for printing the label.

---

*Further steps:*



- *Save your configuration before closing.*

### **Configuring Function Key for Message Forwarding via Telephone Menu**

*Requirements:*

- *An answering machine, put into operation*
- *Knowledge of the telephone, its menu options and the required PIN, if necessary*

1. Press the **menu key** and open the **define keys** menu.
2. Press the **function key** that you would like to define.
3. Select the desired option:
  - first level:** Keys are defined on the first key level.
  - second level:** Keys are defined on the second key level.The list of available functions is displayed.
4. Select the **TAM message fwd.** function.  
The current settings for defining the key are shown on the display.

5. Select the kind of switching. Pressing the  **softkey** allows you to switch over between the different kinds of switching.
  - switch off:** Press the key to disable message forwarding.
  - switch on:** Press the key to enable message forwarding.
  - switch over:** Press the key to switch message forwarding on and off.
6. Press the  **softkey** to accept the setting.

---

## Configuring Announcement for Message Forwarding

Before the new messages are played back, the person being called hears the default announcement FORWARD.WAV.

Instead of the default announcement, you can configure your own announcement for message forwarding.

The configuration can be made as follows:

- Via COMfortel Set
- Via the telephone menu

### Configuring Announcement for Message Forwarding via COMfortel Set

*Requirements:*

- An answering machine, put into operation
- An open configuration and the required PIN, if necessary

1. Open the page **Answering machine > Message forwarding**.
2. Select the desired announcement from the **Announcement** list field.

If you would like to select an announcement that is stored on the telephone SD card in the ANNOUNCE directory, but is not listed as a selection in the list field, click . The announcements are read from the SD card and then displayed in the list field.

*Further steps:*

- Save your configuration before closing.

## **Configuring Announcement for Message Forwarding via Telephone Menu**

### *Requirements:*

- *An answering machine, put into operation*
- *Knowledge of the telephone, its menu options and the required PIN, if necessary*

1. Press the **menu key** and open the menu **answer.machine > settings > fwd announcement**.

The ● icon indicates the current setting.

2. Select the desired option:

**own announcement:** Switches on a customized announcement for message forwarding.

**standard announc:** Switches on the default announcement for message forwarding. (No other action is required.)

3. Scroll through the announcement list to your selection.

The name of the announcement along with the creation date and time is displayed.

4. Press the ✓ **softkey** to accept the announcement.

---

## **Configuring a Message Forwarding Target**

A telephone number can be entered as a target for message forwarding. The new messages on the answering machine should be forwarded to the telephone number.

The configuration can be carried out as follows:

- Via COMfortel Set
- Via the telephone menu

## **Configuring Function Key for Message Forwarding Target via COMfortel Set**

### *Requirements:*

- *An answering machine, put into operation*
- *An open configuration and the required PIN, if necessary*

1. Open the page **Answering machine > Message forwarding**.
2. In the **Destination number** entry field, enter the destination number for message forwarding.

Up to 20 digits

Digits and characters

---

**Note:** Click  to accept a telephone number from the telephone book.

---

3. In the **Destination number** list field, select one of the following options:
  - Internal no.:** Defines the destination number entered as an internal telephone number.
  - External no.:** Defines the destination number entered as an external telephone number.

*Further steps:*

- *Save your configuration before closing.*

### **Configuring Function Key for Message Forwarding Target via Telephone Menu**

*Requirements:*

- *An answering machine, put into operation*
- *Knowledge of the telephone, its menu options and the required PIN, if necessary*

1. Press the **menu key** and open the menu **answer.machine > settings > forward.target**.

---

**Note:** If you press the **telephone book key** before entering the destination number, you can select the desired phone number from the telephone book.

---

2. Enter the destination number. The following entries are possible:

Up to 40 digits

Digits and the characters \* and #

---

**Important:** Enter telephone numbers exactly as when dialling, for example, external telephone numbers always with a leading exchange line access number. (exception: direct exchange access). The default exchange line access number on the PBX is "0" in the factory settings; however, this can be changed for several PBXs (see the PBX manual).

---

3. Press the  **softkey** to save the entry.

---

## Configuring Waiting Period for Message Forwarding

The waiting period for message forwarding indicates how many seconds after which a message that has just arrived is automatically forwarded.

The configuration can be made as follows:

- Via COMfortel Set
- Via the telephone menu

### Configuring Function Key for Message Forwarding via COMfortel Set

*Requirements:*

- An answering machine, put into operation
- An open configuration and the required PIN, if necessary

1. Open the page **Answering machine > Message forwarding**.
2. Enter a value in the **Waiting period (in seconds)** entry field. The following entries are possible:
  - 0:** A message that has just arrived is forwarded immediately.
  - 1 to 99:** After 1 to 99 minutes, a call that has recently arrived is forwarded, depending on the entry.

*Further steps:*

- Save your configuration before closing.

## **Configuring Function Key for Message Forwarding via Telephone Menu**

### *Requirements:*

- *An answering machine, put into operation*
- *Knowledge of the telephone, its menu options and the required PIN, if necessary*

1. Press the **menu key** and open the menu **answer.machine > settings > forwarding time**.
2. Enter a value. The following entries are possible:
  - 0:** A message that has just arrived is forwarded immediately.
  - 1 to 99:** After 1 to 99 seconds, a call that has recently arrived is forwarded, depending on the entry.
3. Press the **✓ softkey** to save the entry.

---

## **Configuring Message Forwarding Repetition**

Message forwarding repetition indicates how often message forwarding should be reattempted if it cannot be carried out successfully. This is the case, for example, if the subscriber could not be reached with the destination number entered or a new message could not be played back in its entirety.

The repetition waiting period indicates how many minutes should elapse between the individual attempts to repeat message forwarding.

The configuration can be made as follows:

- Via COMfortel Set
- Via the telephone menu

## **Configuring Function Key for Message Forwarding Repetition via COMfortel Set**

### *Requirements:*

- *An answering machine, put into operation*
- *An open configuration and the required PIN, if necessary*

1. Open the page **Answering machine > Message forwarding**.

2. In the **Number of repetitions** list field, select one of the following options:
  - None:** No attempt is made to repeat message forwarding.
  - 1...9:** Depending on the selection, message forwarding may be repeated 1 to 9 times.
3. In the **Number of repetitions** list field, select one of the following options:
  - 0 minutes...9 minutes:** 0 to 9 minutes lie between the separate attempts, depending on the selection.

*Further steps:*

- *Save your configuration before closing.*

### **Configuring Function Key for Message Forwarding Repetition via Telephone Menu**

*Requirements:*

- *An answering machine, put into operation*
- *Knowledge of the telephone, its menu options and the required PIN, if necessary*

1. Press the **menu key** and open the menu **answer.machine > settings > fwd.repetitions**
2. Enter a value. The following entries are possible:
  - 0:** No attempt is made to repeat message forwarding.
  - 1 to 9:** Depending on the entry, message forwarding may be repeated 1 to 9 times.
3. Press the **✓ softkey** to save the entry.
4. Press the **menu key** and open the menu **answer.machine > settings > fwd.repet.time.**
5. Enter a value. The following entry is possible:
  - 0 to 9:** 0 to 9 minutes lie between the separate attempts, depending on the entry.
6. Press the **✓ softkey** to save the entry.

## Data Exchange

COMfortel Set can be used to transfer data, for example, recorded announcements, from the SD card to a PC or, in the other direction, from a PC to an SD card.

If the SD card is inserted into the SD slot on the telephone, a directory structure is automatically created on the SD card. The root directory of this directory structure is named CF2500. The following directories are created in this directory:

- ANNOUNCE (location where newly recorded announcements are saved)
- BACKUP (location of the backups)
- MEMO (location of the memos)
- MESSAGES (location of the messages and call recordings)
- RINGTONE (location of the ringer melodies)
- SYSTEM (location of the synthetically generated signal tones as well as the standard announcements in the various languages)

---

### Transferring Data from PC to SD Card

The transmission can be carried out as follows:

- Via COMfortel Set

#### *Requirements:*

- An open configuration and the required PIN, if necessary
- An SD card inserted in the SD slot

You would like to transfer data saved on your computer to the SD card on your telephone. Proceed as described in the following.

1. Open the page **Answering machine > Data exchange**.

When you open this page for the first time, a dialogue for reading out the directory structure on the SD card opens.

- a) Click **Yes**.

The directory structure on the SD card is read out and then displayed under **SD card**.



2. Under **PC**, select the file or the directory in the directory tree that you would like to transfer to the SD card.

---

**Note:**

You can also transfer multiple files/directories to the SD card at the same time.

If you let the cursor hover over a file for a few seconds, a tool tip automatically opens with information about the corresponding file.

If you would like to listen to an announcement or recording stored on the PC on the loudspeaker, select the corresponding WAVE file and click .

3. Select the target directory in the directory tree under **SD card**, into which the data from the PC should be copied.
4. Click .

The data is transferred to the SD card.

---

**Note:**

WAVE files with 8 kHz, 8-bit and A-law encoding (also referred to as CCITT A-law) can be read from the SD card.

You can create a maximum of five directory levels one below the other in the directory tree under **SD card**, because otherwise problems may occur when the data is read out.

---

---

## Transferring Data from SD Card to PC

The transmission can be carried out as follows:

- Via COMfortel Set

*Requirements:*

- An open configuration and the required PIN, if necessary
- An SD card inserted in the SD slot

You would like to transfer a file saved on the SD card on your telephone to your PC. Proceed as described in the following.

1. Open the page **Answering machine > Data exchange**.

When you open this page for the first time, a dialogue for reading out the directory structure on the SD card opens.

- a) Click **Yes**.

The directory structure on the SD card is read out and then displayed under **SD card**.

2. Select the file or the directory in the directory tree under **SD card** that you would like to transfer to the PC.

---

**Note:**

You can also transfer multiple files/directories to the PC at the same time.

If you let the cursor hover over a file for a few seconds, a tool tip automatically opens with information about the corresponding file.

The WAVE files for messages and call recordings (MESSAGES directory) generally display the date and time as well as the telephone number/caller name. Missing information is indicated by a dash.

---

3. Select the target directory in the directory tree under **PC**, in which the data from the SD card are to be copied.

---

**Note:**

If you would like to refresh the directory tree under **PC**, click .

If you would like to create a new directory in the directory tree under **PC**, click .

If you would like to select a different root directory in the directory tree under **PC**, click . Select the desired directory and click **Open** (this text is dependent on the operating system used).

---

4. Click .

The data is transferred to the PC.

## Delete Data from SD Card/PC

Deleting can be carried out as follows:

- Via COMfortel Set

### *Requirements:*

- An open configuration and the required PIN, if necessary
- An SD card inserted in the SD slot

You would like to delete data that is saved on your SD card or PC. Proceed as described in the following.

1. Open the page **Answering machine > Data exchange**.

When you open this page for the first time, a dialogue for reading out the directory structure on the SD card opens.

- a) Click **Yes**.

The directory structure on the SD card is read out and then displayed under **SD card**.

2. Select the file or directory that you would like to delete in the directory tree under **SD card/PC**.

---

**Note:** You can also delete multiple files/directories at one time.

---

3. Click .

4. Click **Yes**.

The data is deleted.

## Selecting Another Telephone for Data Exchange

The selection can be carried out as follows:

- Via COMfortel Set

### *Requirements:*

- An open configuration and the required PIN, if necessary
- An SD card inserted in the SD slot

You would like to select another telephone for the data exchange. Proceed as described in the following.

1. Open the page **Answering machine > Data exchange**.

When you open this page for the first time, a dialogue for reading out the directory structure on the SD card opens.

- a) Click **Yes**.

The directory structure on the SD card is read out and then displayed under **SD card**.

2. Click .

The **Connection routes** dialogue opens with the devices connected via the interface configured above.

3. Select the telephone that you would like to use to carry out the data exchange and click **OK**.

The **PIN entry** dialogue opens.

---

**Note:** For operation on the PBXs COMpact 3000, COMpact 5010 VoIP, COMpact 5020 VoIP, COMmander Basic.2 and COMmander Business, access to the telephone is only possible via the 6-digit PIN assigned in the PBX. In this case, you need to first select which PIN you would like to enter based on the authority level: the Admin PIN, one of the subadmin PIN or the user PIN that belongs to the telephone.

---

4. Enter the associated PIN and click **OK**.

## Saving Standard Announcements on Telephone

COMfortel Set offers standard announcements in German, English and Italian, which can be loaded on the SD card of the telephone if necessary. The standard announcements include the announcement for call acceptance STANDARD.WAV, the announcement for remote access REMOTE.WAV and the announcement for message forwarding FORWARD.WAV.

The saving procedure can be carried out as follows:

- Via COMfortel Set

### Requirements:

- An open configuration and the required PIN, if necessary
- An SD card inserted in the SD slot

1. Open the page **Answering machine > Data exchange**.

When you open this page for the first time, a dialogue for reading out the directory structure on the SD card opens.

- a) Click **Yes**.

The directory structure on the SD card is read out and then displayed under **SD card**.

2. Click the **Standard announcement** tab.
3. Click the national flag for the desired language located next to one of the following options:

**German standard announcements:** German standard announcements are saved on the telephone.

**English standard announcements:** English standard announcements are saved on the telephone.

**Italian standard announcements:** Italian standard announcements are saved on the telephone.

The standard announcements for the desired language are uploaded onto the SD card in the SYSTEM directory under the corresponding language abbreviation.

---

**Note:** The standard announcements used – whether German, English or Italian – depend on the language set on the telephone. The English standard announcements are used for all languages except German and Italian.

---

# Configuring and Managing the Telephone

This section describes how to configure and manage your telephone.

## Topics

- [Identification \(page 455\)](#)
- [Protection from Unauthorised Access \(page 457\)](#)
- [Display and Backlight \(page 463\)](#)
- [Call Signalling \(page 470\)](#)
- [Ringer Melodies \(page 478\)](#)
- [Call Charges \(page 484\)](#)
- [Receiver and Headset \(page 486\)](#)
- [Menu and Function Keys \(page 492\)](#)

# Identification

The telephone must be uniquely identified on the PBX.

---

## Configuring MSN

In order for the PBX to identify the telephone, the internal telephone number (MSN) for the telephone must be entered.

The configuration can be made as follows:

- Via the configuration manager
- Via the telephone menu

### Configuring MSN via COMfortel Set

*Requirements:*

– *An open configuration and the required PIN, if necessary*

1. Open the page **Settings/functions > Basic settings**.
2. In the **Internal number**, enter the internal telephone number (MSN).

---

**Important:** Use each of the internal subscriber telephone numbers for only one of the devices.

---

*Further steps:*

– *Save your configuration before closing.*

## **Configuring MSN via Telephone Menu**

### *Requirements:*

- *Knowledge of the telephone, its menu options and the required PIN, if necessary*
- *The internal telephone number for the telephone configured on the PBX*

1. Press the **menu key** and open the menu **settings > def. settings > MSN**.
2. Enter the internal telephone number (MSN).

---

**Important:** Use each of the internal subscriber telephone numbers for only one of the devices.

---

3. Press the **✓ softkey** to save the entry.



## Protection from Unauthorised Access

In order to prevent important settings from being changed accidentally or by unauthorised people, the telephone can be protected from unauthorised access.

When operating the PBXs COMpact 3000, COMpact 5010 VoIP, COMpact 5020 VoIP, COMmander Basic.2 and COMmander Business, access to the telephone is subdivided into four authorisation levels:

- Administrator (access via admin PIN on the PBX)
- Sub-administrator (access via one of the four sub-admin PINs on the PBX)
- User (access via user PIN assigned to subscriber)
- Guests (unprotected access)

The PINs are transmitted from the PBX and cannot be changed in the telephone itself.

When operating on the PBXs COMpact 2204 USB, COMpact 2206 USB, COMpact 4406 DSL, COMpact 4410 USB and COMmander Basic, access to the telephone is subdivided into two authorisation levels:

- User (access via user PIN)
- Guests (unprotected access)

The user PIN is configured in the telephone.

---

### Configuring User PIN

---

**Important:** Only available when operated on the PBXs COMpact 2204 USB, COMpact 2206 USB, COMpact 4406 DSL, COMpact 4410 USB and COMmander Basic.

---

The configuration can be carried out as follows:

- Via the telephone menu

*Requirements:*

– Knowledge of the telephone, its menu options and the required PIN, if necessary

1. Press the **menu key** and open the menu **settings > blocking > change user PIN**.
2. Enter the user PIN and press the **✓ softkey**.
3. Enter the user PIN for a second time and press the **✓ softkey**.

---

**Note:** You can delete the PIN by not entering any PIN in both menus but by only pressing the **✓ softkey**.

---

---

## Configuring a Function Lock

The functions available in the function menu and key definition menu can be blocked from unauthorised use. The display of these restricted functions in the selection list requires entering the corresponding PIN after selecting **additional** at the end of the selection list.

---

**Note:** A function key defined with a restricted function cannot be used without entering a PIN. This means that the administrator can, for example, enable the switching on/off of a specific call forwarding configuration via the function key even though the ability to configure any number of call forwarding configurations is restricted.

---

The configuration can be carried out as follows:

- Via COMfortel Set
- Via the telephone menu

### Configuring Function Lock via COMfortel Set

*Requirements:*

– *An open configuration and the required PIN, if necessary*

1. Open the page **Settings/functions > Restrictions**.
2. Click the **Telephone menu functions** tab.

3. Select one of the following options for the function to be blocked.

**No restrictions:** The function is not blocked.

**Guests:** Blocks the function in question from guests.

**Guests + users:** Blocks the function in question from guests and users.

**Guests + users + SubAdmin:** Blocks the function in question from guests, users and sub-administrators.

If you would like to restrict all of the functions, select one of the following options under **All - restricted for**.

**No restrictions:** No function is blocked.

**Guests:** Blocks all functions for guests.

**Guests + users:** Blocks all functions for guests and users.

**Guests + users + SubAdmin:** Blocks all functions for guests, users and sub-administrators.

*Further steps:*

- *Save your configuration before closing.*

### **Configuring Function Lock via Telephone Menu**

*Requirements:*

- *Knowledge of the telephone, its menu options and the required PIN, if necessary*

1. Press the **menu key** and open the menu **settings > blocking > function lock**.

The **○○○** icon indicates no blocking.

The **●○○** icon indicates that guests are blocked.

The **●●○** icon indicates that guests and users are blocked.

The **●●●** icon indicates that guests, users and sub-administrators are blocked.

2. Select the function to be blocked.

The menu for restricting the selected function is opened.

3. Enable one of the following options:
  - Sub Admin:** Blocks the function in question from guests, users and sub-administrators.
  - user:** Blocks the function in question from guests and users.
  - guests:** Blocks the function in question from guests.
  - no blocking:** The function is not blocked.
4. Press the  **softkey** to end the configuration for this function.  
The modified settings are displayed, and you can select another function.
5. Press the  **softkey** to accept the setting.

---

## Configuring Settings Lock

The settings that can be selected in the settings menu can be restricted from unauthorised use. The display of these restricted settings in the selection list requires entering the corresponding PIN after selecting **additional** at the end of the selection list.

The configuration can be carried out as follows:

- Via COMfortel Set
- Via the telephone menu

### Configuring Settings Lock via COMfortel Set

*Requirements:*

– An open configuration and the required PIN, if necessary

1. Open the page **Settings/functions > Restrictions**.
2. Click the **Telephone menu settings** tab.
3. Select one of the following options for the setting to be blocked.
  - No restrictions:** The setting is not blocked.
  - Guests:** Blocks the setting in question from guests.

**Guests + users:** Blocks the setting in question from guests and users.

**Guests + users + SubAdmin:** Blocks the setting in question from guests, users and sub-administrators.

If you would like to restrict all of the settings, select one of the following options under **All - restricted for**.

**No restrictions:** No settings are blocked.

**Guests:** Blocks all settings for guests.

**Guests + users:** Blocks all settings for guests and users.

**Guests + users + SubAdmin:** Blocks all settings for guests, users and sub-administrators.

*Further steps:*

– *Save your configuration before closing.*

### **Configuring Settings Lock via Telephone Menu**

*Requirements:*

– *Knowledge of the telephone, its menu options and the required PIN, if necessary*

1. Press the **menu key** and open the menu **settings > blocking > settings lock**.  
The ◻◻◻ icon indicates no blocking.  
The ◻◻◻ icon indicates that guests are blocked.  
The ◻◻◻ icon indicates that guests and users are blocked.  
The ◻◻◻ icon indicates that guests, users and sub-administrators are blocked.
2. Select the setting to be blocked.  
The menu for blocking the selected setting is opened.
3. Enable one of the following options:
  - Sub Admin:** Blocks the setting in question from guests, users and sub-administrators.
  - user:** Blocks the setting in question from guests and users.
  - guests:** Blocks the setting in question from guests.
  - no blocking:** The setting is not blocked.

4. Press the **✓ softkey** to end the configuration for this setting.  
The modified settings are displayed, and you can select another setting.
5. Press the **✓ softkey** to accept the setting.

# Display and Backlight

---

## Configuring the Language on Telephone

This setting specifies the language used on the telephone display.

The configuration can be made as follows:

- Via COMfortel Set
- Via the telephone menu

### Configuring the Language on Telephone via Telephone Menu

*Requirements:*

– *Knowledge of the telephone, its menu options and the required PIN, if necessary*

1. Press the **Menu** key and open the menu **settings > def. settings > language**.

---

**Note:** To open the **language** menu, you can also press the **menu key**, **#** and **0** in that order.

---

The ● icon indicates the current setting.

2. Select the desired display language.

---

## Configuring Display Backlight (only for COMfortel 2500)

The display backlight on the telephone can be adapted according to individual work place requirements.

The configuration can be made as follows:

- Via COMfortel Set
- Via the telephone menu

## **Configuring Display Backlight via COMfortel Set**

### *Requirements:*

- *An open configuration and the required PIN, if necessary*

1. Open the page **Settings/functions > Display**.
2. In the **Display backlight** list field, select one of the following options:

**automatically:** As soon as a key is pressed, the receiver is picked up or the telephone is called, the backlight is switched on (brightness max.) and remains in this state afterwards for short transitional period. Otherwise, the backlight remains on a standby level (brightness min.).

**Permanently switched on during a call:** In addition to the times available in the **automatically** selection, the backlight remains switched on for the entire duration of a call and afterwards for a short transitional period.

**off:** Switches off the backlight completely.

---

**Note:** The **Permanently switched on during a call** and **automatically** selections require additional configuration of the brightness.

---

### *Further steps:*

- *Save your configuration before closing.*

## **Configuring Display Backlight via Telephone Menu**

### *Requirements:*

- *Knowledge of the telephone, its menu options and the required PIN, if necessary*

1. Press the **menu key** and open the menu **settings > display > display light**.  
The ● icon indicates the current setting.
2. Select the desired option:

**switch off:** Switches off the backlight completely.



**on during call:** In addition to the times available in the **automatically** selection, the backlight remains switched on for the entire duration of a call and afterwards for a short transitional period.

**automatically:** As soon as a key is pressed, the receiver is picked up or the telephone is called, the backlight is switched on (brightness max.) and remains in this state afterwards for short transitional period. Otherwise, the backlight remains on a standby level (brightness min.).

---

**Note:** The selection **on during call** or **automatically** requires additional configuration of the brightness.

---

---

## Configuring Brightness (only for COMfortel 2500)

The configuration can be made as follows:

- Via the telephone menu

### *Requirements:*

- Knowledge of the telephone, its menu options and the required PIN, if necessary
- Generally enabled display backlight

1. Press the **menu key** and open the menu **settings > display > brightness (min)**.
2. Press the **-** and **+** **softkeys** to configure the desired basic brightness on the display while the telephone is in the idle state.
3. Press the **✓ softkey** to accept the setting.
4. Select **brightness (max.)**.
5. Press the **-** and **+** **softkeys** to configure the desired brightness on the display for calls during operation.
6. Press the **✓ softkey** to accept the setting.

## Adjusting Contrast

The configuration can be made as follows:

- Via the telephone menu

### *Requirements:*

– *Knowledge of the telephone, its menu options and the required PIN, if necessary*

1. Press the **menu key** and open the menu **settings > display > contrast**.
2. Press the **-** and **+** **softkeys** to configure the desired contrast.
3. Press the **✓** **softkey** to accept the setting.

---

## Switching the Inverse Display View On/Off (only for COMfortel 2500)

If the inverse display view is switched on, the text on the display is light-coloured and the background is dark.

Switching this on/off can be done as follows:

- Via COMfortel Set
- Via the telephone menu

### Switching the Inverse Display View On/Off via COMfortel Set

#### *Requirements:*

– *An open configuration and the required PIN, if necessary*

1. Open the page **Settings/functions > Display**.
2. Select or clear the **Inverse display view** check box.
  - Enables the inverse display view function on the display.
  - Disables the inverse display view function on the display.

#### *Further steps:*

– *Save your configuration before closing.*

## **Switching Inverse Display View On/Off via Telephone Menu**

### *Requirements:*

– Knowledge of the telephone, its menu options and the required PIN, if necessary

1. Press the **menu key** and open the menu **settings > display > inverse view**.
2. Select or clear the **inverse view** check box.
  - Enables the inverse display view function on the display.
  - Disables the inverse display view function on the display.
3. Press the **✓ softkey** to accept the setting.

---

## **Configuring Time Format**

This setting specifies the format in which time is depicted on the display.

The configuration can be made as follows:

- Via COMfortel Set
- Via the telephone menu

### **Configuring Time Format via COMfortel Set**

#### *Requirements:*

– An open configuration and the required PIN, if necessary

1. Open the page **Settings/functions > Display**.
2. In the **Time format** list field, select one of the following options:
  - HH.MM**: Selects the time format in the order of hour, minute separated by a point.
  - HH:MM**: Selects the time format in the order of hour, minute separated by a colon.

#### *Further steps:*

– Save your configuration before closing.

## **Configuring Time Format via Telephone Menu**

### *Requirements:*

– Knowledge of the telephone, its menu options and the required PIN, if necessary

1. Press the **menu key** and open the menu **settings > display > time format**.

The ● icon indicates the current setting.

2. Select one of the following options:

**HH:MM:** Selects the time format in the order of hour, minute separated by a colon.

**HH.MM:** Selects the time format in the order of hour, minute separated by a point.

---

## **Configuring Date Format**

The date format selected here is displayed, for example, in the caller and calls lists. In the idle state, this format is modified as follows:

The month is depicted with three letters and the year is omitted (for example, 03. Jun).

The configuration can be made as follows:

- Via COMfortel Set
- Via the telephone menu

## **Configuring Date Format via COMfortel Set**

### *Requirements:*

– An open configuration and the required PIN, if necessary

1. Open the page **Settings/functions > Display**.

2. In the **Date format** list field, select one of the following options:

**DD.MM.YY**: Selects the date format in the order of day, month, year separated by points.

**DD/MM/YY**: Selects the date format in the order of day, month, year separated by slashes.

**DD-MM-YY**: Selects the date format in the order of day, month, year separated by hyphens.

**YY-MM-DD**: Selects the date format in the order of year, month, day separated by hyphens.

*Further steps:*

- *Save your configuration before closing.*

### **Configuring Call Date Format via Telephone Menu**

*Requirements:*

- *Knowledge of the telephone, its menu options and the required PIN, if necessary*

1. Press the **menu key** and open the menu **settings > display > date format**.

The ● icon indicates the current setting.

2. Select one of the following options:

**DD.MM.YY**: Selects the date format in the order of day, month, year separated by points.

**DD/MM/YY**: Selects the date format in the order of day, month, year separated by slashes.

**DD-MM-YY**: Selects the date format in the order of day, month, year separated by hyphens.

**YY-MM-DD**: Selects the date format in the order of year, month, day separated by hyphens.

# Call Signalling

The system telephone can signal incoming calls as follows:

- Ring signal (the telephone rings with a configured ringer melody)
- Display message (text)
- Flashing LED above the hook key
- Display backlight (only for COMfortel 2500)
- Display backlight with flashing signal (only for COMfortel 2500)

---

## Switching Ring Signal On/Off

If the ring signal is enabled, calls are acoustically signalled by a ring signal. If you don't want your environment to be disturbed by the ringer on the telephone, you can switch off the ring signal.

This function is different than the do-not-disturb function on the PBX in that calls are still possible. However, they are no longer signalled acoustically but rather visually.

Switching this on/off can be done as follows:

- Via COMfortel Set
- Via the telephone menu

### Switching Ring Signal On/Off via COMfortel Set

*Requirements:*

– An open configuration and the required PIN, if necessary

1. Open the page **Settings/functions > Signalling/ringer**.
2. Select or clear the **Ring signal** check box.
  - Enables the ring signal.
  - Disables the ring signal.

*Further steps:*

– Save your configuration before closing.

## **Switching Ring Signal On/Off via Telephone Menu**

### *Requirements:*

– *Knowledge of the telephone, its menu options and the required PIN, if necessary*

1. Press the **menu key** and open the menu **functions > ringer tone**.

The ● icon indicates the current setting.

2. Select the desired option:

**switch on:** Enables the ring signal.

**switch off:** Disables the ring signal.

---

## **Configuring and Operating Function Key for Ring Signal**

Press the key to switch the ring signal on or off or to switch it over.

Press the key during an incoming call to switch the ring signal on or off for this call or to switch it over.

In addition, when functions are defined on the first key level, the status of the function is indicated by the corresponding LED.

### **LED signalling next to the key:**

Off            The ring signal is enabled.

Red            The ring signal is disabled.

The configuration can be carried out as follows:

- Via COMfortel Set
- Via the telephone menu

## **Configuring Function Key for Ring Signal via COMfortel Set**

### *Requirements:*

– *An open configuration and the required PIN, if necessary*

1. Open the page **Function keys > Assign function keys**.
2. Only available in installed extension modules: In the telephone displayed at the top left, click the key group in which you would like to define keys.
3. Click one of the following tabs:
  - Level 1:** Keys are defined on the first key level.
  - Level 2:** Keys are defined on the second key level.
4. Right-click the function key you want to assign.  
A function selection dialogue opens.
5. Select the **Ring signal** function.  
The current settings for defining the key are displayed.
6. In the **Kind of switching** list field, select one of the following options:
  - switch off:** Press the key to disable the ring signal.
  - switch on:** Press the key to enable the ring signal.
  - switch over:** Press the key to switch the ring signal on and off.
7. In the **Key name** entry field, enter a name for the key. The following entries are possible:
  - Up to 16 digits
  - Digits and characters

Clicking  automatically enters the default name in the entry field.

---

**Note:** The key name is used for printing the label.

---

*Further steps:*

- *Save your configuration before closing.*



### **Configuring Function Key for Ring Signal via Telephone Menu**

*Requirements:*

- *Knowledge of the telephone, its menu options and the required PIN, if necessary*

1. Press the **menu key** and open the **define keys** menu.



2. Press the **function key** that you would like to define.
3. Select the desired option:
  - first level:** Keys are defined on the first key level.
  - second level:** Keys are defined on the second key level.The list of available functions is displayed.
4. Select the **ringer tone** function.  
The current settings for defining the key are shown on the display.
5. Select the kind of switching. Press the  **softkey** to switch over between the different kinds of switching.
  - switch off:** Press the key to disable the ring signal.
  - switch on:** Press the key to enable the ring signal.
  - switch over:** Press the key to switch the ring signal on and off.
6. Press the  **softkey** to accept the setting.

---

### Switching Flashing Display Backlight for Call Signalling On/Off (only for COMfortel 2500)

If you don't want your environment to be disturbed by the ringer on the telephone, you can signal calls instead by having the display backlight flash (in addition to the other visual signals). Depending on the brightness in the room, this can be a highly noticeable visual signal.



**Warning:** Certain blinking frequencies can possibly trigger epileptic seizures. Those suffering from or in danger of epileptic seizures should therefore avoid using this function.

---

Switching this on/off can be done as follows:

- Via COMfortel Set
- Via the telephone menu

## **Switching Call Signalling by Flashing Display Backlight On/Off via COMfortel Set**

### *Requirements:*

– An open configuration and the required PIN, if necessary

1. Open the page **Settings/functions > Signalling/ringer**.
2. Select or clear the **Call signal/light** check box.
  - Enables call signalling by a flashing display backlight.
  - Disables call signalling by a flashing display backlight.

### *Further steps:*

– Save your configuration before closing.

## **Switching Call Signalling by Flashing Display Backlight On/Off via Telephone Menu**

### *Requirements:*

– Knowledge of the telephone, its menu options and the required PIN, if necessary

1. Press the **menu key** and open the menu **functions > call signal/light**.  
The ● icon indicates the current setting.
2. Select the desired option:
  - switch on:** Enables call signalling by a flashing display backlight.
  - switch off:** Disables call signalling by a flashing display backlight.

---

## **Configuring and Operating Function Key for Call Signalling by Flashing Display Backlight (only for COMfortel 2500)**

Press the key while in the telephone's idle state to switch call signalling by the flashing display backlight on or off or to switch it over.

In addition, when functions are defined on the first key level, the status of the function is indicated by the corresponding LED.

**LED signalling next to the key:**

- off                Call signalling by a flashing display backlight is disabled.
- Red                Call signalling by a flashing display backlight is enabled.

The configuration can be carried out as follows:

- Via COMfortel Set
- Via the telephone menu

**Configuring Function Key for Call Signalling by Flashing Display Backlight via COMfortel Set**

*Requirements:*

- An open configuration and the required PIN, if necessary

1. Open the page **Function keys > Assign function keys**.
2. Only available in installed extension modules: In the telephone displayed at the top left, click the key group in which you would like to define keys.
3. Click one of the following tabs:
  - Level 1:** Keys are defined on the first key level.
  - Level 2:** Keys are defined on the second key level.
4. Right-click the function key you want to assign.  
A function selection dialogue opens.
5. Select the **Call signal/light** function.  
The current settings for defining the key are displayed.
6. In the **Kind of switching** list field, select one of the following options:
  - switch off:** Press the key to switch call signalling by a flashing display backlight off.

**switch on:** Press the key to switch call signalling by a flashing display backlight on.

**switch over:** Press the key to switch call signalling by a flashing display backlight on and off.

7. In the **Key name** entry field, enter a name for the key. The following entries are possible:

Up to 16 digits

Digits and characters

Clicking  automatically enters the default name in the entry field.

---

**Note:** The key name is used for printing the label.

---

*Further steps:*

- *Save your configuration before closing.*

### **Configuring Function Key for Call Signalling by Flashing Display Backlight via Telephone Menu**

*Requirements:*

- *Knowledge of the telephone, its menu options and the required PIN, if necessary*

1. Press the **menu key** and open the **define keys** menu.
2. Press the **function key** that you would like to define.
3. Select the desired option:

**first level:** Keys are defined on the first key level.

**second level:** Keys are defined on the second key level.

The list of available functions is displayed.

4. Select the **call signal/light** function.

The current settings for defining the key are shown on the display.

5. Select the kind of switching. Press the  **softkey** to switch over between the different kinds of switching.

**switch off:** Press the key to switch call signalling by a flashing display backlight off.

**switch on:** Press the key to switch call signalling by a flashing display backlight on.

**switch over:** Press the key to switch call signalling by a flashing display backlight on and off.

6. Press the  **softkey** to accept the setting.

# Ringer Melodies

---

## Determining Different Types of Calls

There are 16 (COMfortel 2500) or 8 (COMfortel 1500) different ringer melodies available to differentiate between types of calls. You can use COMfortel Set to add additional WAV files to these ringer melodies (only on COMfortel 2500 with SD card).

The ringer melodies can be assigned to different kinds of calls, callers or call targets. You can make the assignments depending on what information you think is the most important.

Configure the settings as follows:

- If you would like to differentiate between the different kinds of calls by using different ringer melodies, configure the corresponding settings via the telephone menu or via COMfortel Set. The following kinds of calls are available for this:
  - Alarm calls
  - External calls
  - Internal calls
  - Group calling (a call directed to a group)
  - InterCom calls
  - External callback calls
  - Internal callback calls
  - Scheduled calls
  - Door calls
  - Call deblocker calls (calls enabled despite do-not-disturb)
  - Wake-up calls
  - Other calls
- If you would like to differentiate between different callers using different ringer melodies, enter the telephone numbers of these people in a local telephone book and assign the contact in question a specific ringer melody (the prerequisite for this function is that the caller transmits his telephone number).
- If you would like to be notified, using different ringer melodies, which of your external telephone numbers the caller dialled, configure the corresponding settings via COMfortel Set.

---

**Important:** Only available for operation on the PBXs COMpact 3000, COMpact 5010 VoIP, COMpact 5020 VoIP, COMmander Basic.2 and COMmander Business.

---

- If you would like to be notified, using different ringer melodies, which of your groups is being called by the caller, configure the corresponding settings via COMfortel Set.

As external, internal and door terminal calls can be affected by more than one of these four settings, these types of calls are signaled based on a predetermined sequence (priority list). When this is done, the caller is always identified first. If no specific ringer melody has been configured for the caller, the external telephone number or group telephone number dialed by the caller is checked. If no specific ringer melody has been configured for this either, the ringer melody of the kind of call is used.

### **Priority List for External Calls**

1. The ringer melody defined in the telephone book, in as far as the caller can be identified as a telephone book entry
2. For the ringer melody configured for the call type call deblocker, in as much as the caller can be identified even when he has do-not-disturb enabled as a part of a call deblocker
3. For a ringer melody configured for a certain external telephone number, in as much as the telephone number was dialed by the caller
4. For the ringer melody configured for a certain group telephone number, in as much as the group is called
5. For the ringer melody configured for a certain call type group calling, in as much as a non-specified group is called
6. For the ringer melody for the call type external calls

### **Priority List for Internal Calls**

1. The ringer melody defined in the telephone book, in as far as the caller can be identified as a telephone book entry
2. For the ringer melody configured for a certain group telephone number, in as much as the group is called
3. For the ringer melody configured for a certain call type group calling, in as much as a non-specified group is called
4. For the ringer melody for the call type internal calls

### **Priority List for Door Terminal Calls**

1. The ringer melody defined in the telephone book, in as far as the door terminal can be identified as a telephone book entry
2. For the ringer melody for the call type door call

---

## Configuring Ringer Melodies

You have the option of assigning the several call types each a specific ringer melody via the telephone menu.

In addition to making call type-dependent assignments, COMfortel Set can also be used to configure which ringer melody to assign to each of 10 separate external telephone numbers or groups depending on the number.

The configuration can be made as follows:

- Via COMfortel Set
- Via the telephone menu

### Configuring Call Type-dependent Ringer Melodies via COMfortel Set

*Requirements:*

– An open configuration and the required PIN, if necessary

1. Open the page **Settings/functions > Signalling/ringer**.
2. Click the **Ringer melodies (call type-dependent)** tab.
3. If you would like to add your own ringer melodies to the ringer melody list fields, click  next to **Read ringer melodies (\*.wav) from SD card**.

The ringer melodies on the SD card are read out and added to the list fields for the various call types.

---

#### **Note:**

Adding your own ringer melodies is only possible on a COMfortel 2500 with an SD card inserted.

To upload your own ringer melodies to the SD card, open the page **Answering machine > Data exchange** and load any WAV files available in the RINGTONE directory on the SD card.

---

4. Select the desired ringer melody from the list field of call types in question.

*Further steps:*

– *Save your configuration before closing.*



## Configuring Number-dependent Ringer Melodies via COMfortel Set

### *Requirements:*

- An open configuration and the required PIN, if necessary

1. Open the page **Settings/functions > Signalling/ringer**.
2. Click the **Ringer melodies (number-dependent)** tab.
3. In the **Group number 1** to **Group number 10** entry field, enter the telephone numbers of the group and select the desired ringer melody from the list field.
4. In the **External telephone numbers 1** to **External telephone numbers 10** entry field, enter each of your external telephone numbers and select the desired ringer melody in the list field.

---

**Important:** Only available for operation on the PBXs COMcompact 3000, COMcompact 5010 VoIP, COMcompact 5020 VoIP, COMmander Basic.2 and COMmander Business.

---

### *Further steps:*

- Save your configuration before closing.

## Configuring Ringer Melodies via Telephone Menu

### *Requirements:*

- Knowledge of the telephone, its menu options and the required PIN, if necessary

1. Press the **menu key** and open the menu **settings > signalling > ringer melody**.
2. Select the desired call type.  
You hear the currently configured ringer melody. The associated name is shown in the display.
3. Select the desired ringer melody.  
You hear the displayed ringer melody to see if you like it.
4. Press the **✓ softkey** to accept the setting.  
You now have option of configuring the ringer melody for another call type.

## Changing Volume Automatically

You can increase and decrease the volume on the telephone automatically. The telephone starts to ring at the volume you configured and increases/decreases this every 5 seconds by one level until it reaches the maximum/minimal volume.

The change can be made as follows:

- Via COMfortel Set
- Via the telephone menu

### Changing Ringer Volume Automatically via COMfortel Set

*Requirements:*

– An open configuration and the required PIN, if necessary

1. Open the page **Settings/functions > Signalling/ringer**.
2. Under **Automatic change of the ringer volume**, select one of the following options:

**Constant ringer volume:** Selects a steady volume during the entire calling phase.

**Increase the ringer volume automatically:** Selects an automatic increase in the volume during the calling phase.

**Reduce the ringer volume automatically:** Selects an automatic decrease in the volume during the calling phase.

**Single tone:** Selects a single quiet tone instead of the ringer melodies configured.

*Further steps:*

– Save your configuration before closing.

### Changing Ringer Volume Automatically via Telephone Menu

*Requirements:*

– Knowledge of the telephone, its menu options and the required PIN, if necessary

1. Press the **menu key** and open the menu **settings > signalling > ringer volume**.

The ● icon indicates the current setting.

2. Select the desired option:

**steady:** Selects a steady volume during the entire calling phase.

**autom.increase:** Selects an automatic increase in the volume during the calling phase.

**auto-reduction:** Selects an automatic decrease in the volume during the calling phase.

**single ringtone:** Selects a single quiet tone instead of the ringer melodies configured.

# Call Charges

To calculate call charges, the currency of the country as well as the cost per call unit must be configured in COMfortel Set.

---

## Configuring Currency

The configuration can be made as follows:

- Via COMfortel Set

### *Requirements:*

– *An open configuration and the required PIN, if necessary*

1. Open the page **Settings/functions > Basic settings**.
2. In the **Currency (max. 3 characters)** entry field, enter the currency for the charge function on the telephone that should be used. The following entries are possible:

Up to 3 digits

### *Further steps:*

– *Save your configuration before closing.*

---

## Configuring Cost per Call Unit

The configuration can be made as follows:

- Via COMfortel Set

### *Requirements:*

– *An open configuration and the required PIN, if necessary*

1. Open the page **Settings/functions > Basic settings**.
2. In the **Cost per call unit (0-9999 currency subunits)** entry field, enter the cost per call unit. The following entries are possible:

Up to 4 digits

Digits, for example, **6** for 6 cent

---

**Note:** If you configure your telephone as room telephone, the value for cost per call unit should match the value configured in the PBX. Otherwise misunderstandings might occur regarding final invoice because the value configured in the PBX is used for calculating the cost of calls.

---

*Further steps:*

- *Save your configuration before closing.*

# Receiver and Headset

---

## Adjusting Receiver Volume

Whenever necessary, the microphone volume of the receiver can be increased or decreased.

The adjustment can be done as follows:

- Via the telephone menu

### *Requirements:*

– *Knowledge of the telephone and its menu options*

1. Press the **menu key** and open the menu **settings > def. settings > receiver volume**.
2. Press the **-** and **+** **softkeys** to configure the desired microphone volume.
3. Press the **✓** **softkey** to accept the setting.

---

## Switching Headset Operation On/Off

If you have connected a headset to your system telephone and selected it, you can switch between receiver and headset operation.

Switching this on/off can be done as follows:

- Via the telephone menu

### *Requirements:*

– *Knowledge of the telephone, its menu options and the required PIN, if necessary*

In order to switch headset operation on and off, press the function key configured for a headset.

Or, proceed as described in the following.

1. Press the **menu key** and open the menu **functions > headset**.

The ● icon indicates the current setting.

2. Select the desired option:

**switch on:** Enables headset operation.

**switch off:** Enables headset operation.

*Further steps:*

– *If required, switch the automatic call acceptance on.*

---

## Configuring and Operating Function Key for Headset Operation

Press the key to switch headset operation on or off or to switch it over.

In addition, when functions are defined on the first key level, the status of the function is indicated by the corresponding LED.

### LED signalling next to the key:

Green            Headset operation is enabled.

Off                Headset operation is disabled.

The configuration can be carried out as follows:

- Via COMfortel Set
- Via the telephone menu

### Configuring Function Key for Headset Operation via COMfortel Set

*Requirements:*

– *An open configuration and the required PIN, if necessary*

1. Open the page **Function keys > Assign function keys**.
2. Only available in installed extension modules: In the telephone displayed at the top left, click the key group in which you would like to define keys.

3. Click one of the following tabs:
  - Level 1:** Keys are defined on the first key level.
  - Level 2:** Keys are defined on the second key level.
4. Right-click the function key you want to assign.  
A function selection dialogue opens.
5. Select the **Headset** function.  
The current settings for defining the key are displayed.
6. In the **Kind of switching** list field, select one of the following options:
  - switch off:** Enables headset operation.
  - switch on:** Enables headset operation.
  - switch over:** Pressing the key switches headset operation on and off.
7. In the **Key name** entry field, enter a name for the key. The following entries are possible:
  - Up to 16 digits
  - Digits and characters

Clicking  automatically enters the default name in the entry field.

---

**Note:** The key name is used for printing the label.

---

*Further steps:*

- *Save your configuration before closing.*

### **Configuring Function Key for Headset Operation via Telephone Menu**

*Requirements:*

- *Knowledge of the telephone, its menu options and the required PIN, if necessary*

1. Press the **menu key** and open the **define keys** menu.
2. Press the **function key** that you would like to define.



3. Select the desired option:

**first level:** Keys are defined on the first key level.

**second level:** Keys are defined on the second key level.

The list of available functions is displayed.

4. Select the **headset** function.

The current settings for defining the key are shown on the display.

5. Select the kind of switching. Press the  **softkey** to switch over between the different kinds of switching.

**switch off:** Enables headset operation.

**switch on:** Enables headset operation.

**switch over:** Pressing the key switches headset operation on and off.

6. Press the  **softkey** to accept the setting.

---

## Configuring Headset Type

If a headset is connected, the headset type used must be configured.

The configuration can be made as follows:

- Via COMfortel Set
- Via the telephone menu

### Configuring Headset Type via COMfortel Set

*Requirements:*

– An open configuration and the required PIN, if necessary

1. Open the page **Settings/functions > Headset**.
2. Under **Type of headset**, select one of the following options.

**Cable headset:** Selects the cable-connected headset type.

**DHSG headset:** Selects the wireless headset type with a DHSG interface.

*Further steps:*

– Save your configuration before closing.

## **Configuring Headset Type via Telephone Menu**

### *Requirements:*

– Knowledge of the telephone, its menu options and the required PIN, if necessary

1. Press the **menu key** and open the menu **settings > headset > headset type**.  
The ● icon indicates the current setting.
2. Select the desired option:
  - wired headset:** Selects the cable-connected headset type.
  - DHSG headset:** Selects the wireless headset type with a DHSG interface.

---

## **Switching Headset Ringing On/Off**

During headset operation (headset switched on), three types of call signalling are possible:

1. Ringing through the loud speaker (as for receiver operation)
2. Ringing through the loud speaker + a short attention tone on the headset
3. Short attention tone on the headset

For the second and third operating mode, headset ringing must be switched on as described here. For the third operating mode, the ringer must also be switched off.

Switching this on/off can be done as follows:

- Via COMfortel Set
- Via the telephone menu

## **Configuring Headset Ringing via COMfortel Set**

### *Requirements:*

– An open configuration and the required PIN, if necessary

1. Open the page **Settings/functions > Headset**.
2. Select or clear the **Headset ringing** check box.
  - Enables the headset ringer.
  - Disables the headset ringer.

*Further steps:*

- *Save your configuration before closing.*

### **Switching Headset Ringing On/Off via Telephone Menu**

*Requirements:*

- *Knowledge of the telephone, its menu options and the required PIN, if necessary*

1. Press the **menu key** and open the menu **settings > headset > headset ringer**.
2. Select or clear the **headset ringer** check box.
  - Enables the headset ringer.
  - Disables the headset ringer.
3. Press the **✓ softkey** to accept the setting.

---

### **Adjusting Headset Volume**

Whenever necessary, the headset volume can be used to adjust the microphone amplifier on the connected headset upwards (if your communication partner cannot understand you) or downwards (if speech is distorted).

The adjustment can be done as follows:

- Via the telephone menu

*Requirements:*

- *Knowledge of the telephone and its menu options*

1. Press the **menu key** and open the menu **settings > headset > headset volume**.
2. Press the **-** and **+** **softkeys** to configure the desired microphone volume.
3. Press the **✓ softkey** to accept the setting.

# Menu and Function Keys

---

## Restricting Menu Selection

You can adapt the function menu to your own needs. If you would like to only use some of the functions available, you can hide the remaining functions in order to shorten the menu selection. Hiding applies only to the function menu. If the functions in question are also available over a different path, for example, via the key definition menu or an already defined key, this remains available.

The restriction can be carried out as follows:

- Via the telephone menu

### *Requirements:*

– *Knowledge of the telephone, its menu options and the required PIN, if necessary*

1. Press the **menu key** and open the menu **functions > user settings > menu definition**.
2. Enable or disable the desired function.
  - The function in question is shown on the display.
  - The function in question is not shown on the display.
3. Press the **✓ softkey** to accept the setting.

---

## Configuring Accessibility of Second Key Level

The freely programmable function keys can each be defined twice (on two levels). Here, you configure how the second level of the function keys should be operated. The variant **Second level via shift key** is always enabled. If you would like to use this, you must define one of your function keys with the shift function. The variant **Second level via double-click (300 ms)** can be disabled if it is not needed.

The configuration can be made as follows:

- Via COMfortel Set
- Via the telephone menu

### **Configuring Accessibility of Second Key Level via COMfortel Set**

*Requirements:*

– *An open configuration and the required PIN, if necessary*

1. Open the page **Settings/functions > User settings**.
2. Select or clear the **Second-level function via double keypress** check box.
  - Enables pressing the key twice to access the second level.
  - Disables pressing the key twice to access the second level.

*Further steps:*

– *Save your configuration before closing.*

### **Configuring Accessibility of Second Key Level via Telephone Menu**

*Requirements:*

– *Knowledge of the telephone, its menu options and the required PIN, if necessary*

1. Press the **menu key** and open the menu **functions > user settings > keys 2nd level**.
2. Select or clear the **double click** check box.
  - Enables pressing the key twice to access the second level.
  - Disables pressing the key twice to access the second level.
3. Press the **✓ softkey** to accept the setting.

## Configuring and Operating Function Key for Shift

Press the key to access the second key level for a few seconds.

In addition the status of the function is indicated by the corresponding LED.

### LED signalling next to the key:

Red	The second key level is accessible.
Off	The first key level is accessible.

The configuration can be carried out as follows:

- Via COMfortel Set
- Via the telephone menu

### Configuring Function Key for Shift via COMfortel Set

#### *Requirements:*

– An open configuration and the required PIN, if necessary

1. Open the page **Function keys > Assign function keys**.
2. Only available in installed extension modules: In the telephone displayed at the top left, click the key group in which you would like to define keys.
3. Click **Level 1**.

---

**Important:** Configuring this function is only possible on the first level. The second level is then blocked. If a function has been assigned to the second level, it is deleted.

---

4. Right-click the function key you want to assign.  
A function selection dialogue opens.
5. Select the **Shift** function.  
The current settings for defining the key are displayed.

6. In the **Key name** entry field, enter a name for the key. The following entries are possible:

Up to 16 digits

Digits and characters

Clicking  automatically enters the default name in the entry field.

---

**Note:** The key name is used for printing the label.

---

*Further steps:*

- *Save your configuration before closing.*

### **Configuring Function Key for Shift via Telephone Menu**

*Requirements:*

- *Knowledge of the telephone and its menu options*

1. Press the **menu key** and open the **define keys** menu.
2. Press the **function key** that you would like to define.
3. Select **first level**.

---

**Important:** Configuring this function is only possible on the first level. The second level is then blocked. If a function has been assigned to the second level, it is deleted.

---

The list of available functions is displayed.

4. Select the **shift** function.

The current settings for defining the key are shown on the display.

5. Press the **✓ softkey** to accept the setting.

## Exchanging or Moving Function Keys

The exchanging/moving procedure can be carried out as follows:

- Via COMfortel Set

### *Requirements:*

– *An open configuration and the required PIN, if necessary*

1. Open the page **Function keys > Exchange/move**.
2. Click the function key field that you would like to move or exchange.  
The field is selected.
3. Click one of the following options:
  - Exchange:** Exchanges the selected function key after clicking the target field.
  - Move:** Moves the selected function key after clicking the target field.
4. Click the target field to which the selected function key should be moved or with which the function key should be exchanged.

### *Further steps:*

– *Back up your configuration before you leave the PC programme.*



# Configuring and Managing Voice Mailboxes

This section describes how to configure and operate voice mailboxes. Moreover, it shows you how to record announcements, execute remote access, and forward messages, e.g. to a substitute.

## Topics

- [Voice Mailbox \(Seite 498\)](#)
- [Readiness \(Seite 507\)](#)
- [Configuration-Dependent Control \(Seite 512\)](#)
- [Voice Memos \(Seite 517\)](#)
- [Distribution of Messages \(Seite 520\)](#)
- [Announcements \(Seite 524\)](#)
- [Remote Access \(Seite 529\)](#)
- [Message Forwarding \(Seite 535\)](#)
- [Substitute Function \(Seite 540\)](#)

## Voice Mailbox

A voice mailbox which is assigned to the telephone or to a group can be operated like a local answering machine.

It saves the voice messages for an individual subscriber or a group and can be queried any time by the subscriber or the members of the group.

Voice messages and announcements are not stored in the telephone but in the PBX (in contrast to a local answering machine). The size of a voice mailbox is determined by the PBX, as well as the authorization to use it. A voice mailbox can be assigned to an individual subscriber or to a group. Moreover, a subscriber may be granted authorization for several voice mailboxes.

---

**Note:**

The voice mailbox will only function if an optionally available COMmander VMF module is inserted into the COMmander Business or COMmander Basic.2 PBX. For the COMpact 5010 VoIP PBX, an optionally available COMpact 2VoIP module has to be inserted, for COMpact 5020 VoIP an optionally available COMpact 2VoIP or 6VoIP module.

Only for COMfortel 2500/2500 answering machine: The readiness of the local answering machine at the telephone will automatically be switched off if the assigned voice mailbox is used in the PBX. Querying voice messages, as well as replaying and deleting own announcements is still possible. The recording function can still be used.

---

## Opening a Voice Mailbox

Open the voice mailbox to query, replay, or delete messages or move them into an archive. If a subscriber is authorized to query several voice mailboxes, a list of further boxes will be offered for selection in addition to voice mailbox used.

The LED above the message key indicates whether new messages have been received on the voice mailbox.

### LED signalling over the message key:

Off	No messages available.
Red (blinking)	There are new messages. The fill level of at least one assigned voice mailbox has reached the state "almost full" or "full".
Lit in red	There are no new messages. There are only messages which you have already listened to. The fill level of at least one assigned voice mailbox has reached the state "almost full" or "full" and has already been confirmed.

Opening can be carried out as follows:

- Via the telephone menu

### Requirements:

- *COMmander Business or COMmander Basic.2 with inserted COMmander VMF module, COMpact 5010 VoIP with inserted COMpact 2VoIP module, or COMpact 5020 VoIP with inserted COMpact 2VoIP or 6VoIP module*
- *Voice mailbox which is configured in the PBX and assigned to it*
- *Knowledge of the telephone, its menu options and the required PIN, if necessary*

To open the voice mailbox, press the **function key** configured for it or press the **menu key** to open the menu **Voice mailbox > functions > VMB open**.

Alternatively, proceed as described in the following.

1. Press the **message key**.  
The available lists are displayed. To the left next to the selection of lists, the respective numbers of existing recordings and calls are displayed.
2. Select **VMB used** (this is skipped if the other lists are empty).

The following information about the recording is shown on the display:

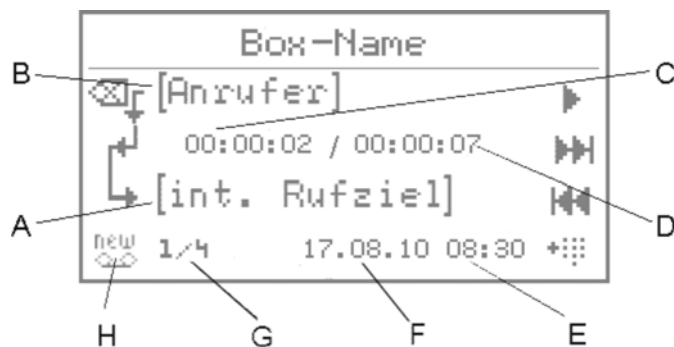

- A Internal call destination
- B Caller
- C Length of time the recording has been replayed
- D Entire length of the recording
- E Time of recording
- F Date of recording
- G Consecutive number of recording/number of existing recordings

---

**Note:** The latest recording is displayed with consecutive number 1.

---

- H Recording type: new message (new), old message already listened to (old).

---

**Note:** If you have activated automatic replay in the PBX, the new recordings are automatically replayed in sequence after the voice mailbox is opened. The latest recording is replayed first.

---

3. Select the desired option:
  - ☒ Deletes the displayed recording. If you press this key for a longer period of time, all messages from the message list will be deleted.
  - ▶ Starts the replay of the recording.
  - || Interrupts the replay of the recording. If you press this key for a longer period of time, the system will go back to the start of the recording.
  - ▶▶ Scrolls to next (older) recording.
  - ◀◀ Scrolls to the previous (more recent) recording.
  - +☰ Accepts the entry into dial preparation or into the telephone book, if applicable.
4. If you would like to leave the menu, press the **Exit key**.

---

## Listening to Recordings

Listening can be carried out as follows:

- Via the telephone menu

### *Requirements:*

- *COMmander Business or COMmander Basic.2 with inserted COMmander VMF module, COMpact 5010 VoIP with inserted COMpact 2VoIP module, or COMpact 5020 VoIP with inserted COMpact 2VoIP or 6VoIP module*
- *Voice mailbox which is configured in the PBX and assigned to it*
- *Knowledge of the telephone, its menu options and the required PIN, if necessary*

1. Open the message list of the voice mailbox.
2. Use the **▶▶ softkeys** and **◀◀** to scroll to the desired recording.
3. Press the **▶ softkey** to start replaying the recording.

---

**Note:** You can also pick-up the receiver to prevent others present from listening.

---

The recording is replayed.

4. Select the desired option:
  - ☒ Deletes the displayed recording. If you press this key for a longer period of time, all messages from the message list will be deleted.
  - ▶ Starts the replay of the recording.
  - || Interrupts the replay of the recording. If you press this key for a longer period of time, the system will go back to the start of the recording.
  - ▶▶ Scrolls to next (older) recording.
  - ◀◀ Scrolls to the previous (more recent) recording.
  - ⋮ Accepts the entry into dial preparation or into the telephone book, if applicable.
5. If you would like to leave the menu, press the **Exit key**.

---

**Note:** You can also access and listen to the recordings remotely.

---

---

## Selecting from the Message List of the Voice Mailbox

### Requirements:

- *COMmander Business or COMmander Basic.2 with inserted COMmander VMF module, COMpact 5010 VoIP with inserted COMpact 2VoIP module, or COMpact 5020 VoIP with inserted COMpact 2VoIP or 6VoIP module*
- *Voice mailbox which is configured in the PBX and assigned to it*
- *Knowledge of the telephone, its menu options and the required PIN, if necessary*

1. Open the message list of the voice mailbox.
2. Use the **▶▶ softkeys** and **◀◀** to scroll to the desired recording.
3. Press the **\*# softkey** in order to accept the telephone number in dial preparation.

---

### Note:

The number cannot be taken over into dial preparation as long as switching between messages is performed.

A callback can only be made if the number of the caller has been transferred.

---

4. Pick up the receiver or press the **hook key**.

The subscriber is called.

---

**Note:** If you would like to exit the menu without dialling the number displayed, hang up the receiver or press the **Exit key**.

---

---

## Configuring and Operating the Function Key to Open the Voice Mailbox

While the telephone is in the idle state, press the key generally assigned for accessing the function and then pick up the receiver to establish a connection to the voice mailbox. If you have been assigned several voice mailboxes, a list of voice mailboxes will be opened which contain messages.

Press the defined and assigned key in the idle state of the telephone to set up a connection to a defined voice mailbox.

If you press the defined and assigned key during recording, you can take over the call or open the assigned voice mailbox.

---

**Note:** Press the function key again to switch from the message entry to archive or vice versa. You can identify the archive by the  before the name of the voice mailbox.

---

In addition, when functions are assigned on the first key level, the status of the voice mailbox is indicated by the corresponding LED.

#### **LED signalling next to the key:**

Green	There are no new messages. There are only messages which you have already listened to in at least one voice mailbox.
Green (blinking)	There are new messages.
Red	A new message is being recorded.
Off	No messages available.

The configuration can be carried out as follows:

- Via COMfortel Set
- Via the telephone menu

### **Configuring the Function Key for General Opening of a Voice Mailbox via COMfortel Set**

#### *Requirements:*

- *COMmander Business or COMmander Basic.2 with inserted COMmander VMF module, COMpact 5010 VoIP with inserted COMpact 2VoIP module, or COMpact 5020 VoIP with inserted COMpact 2VoIP or 6VoIP module*
- *Voice mailbox which is configured in the PBX and assigned to it*
- *An open configuration and knowledge of the required PIN, if necessary*

1. Open the page **function keys > assign function keys**.
2. Only available in installed extension modules: In the telephone displayed at the top left, click the key group in which you would like to assign keys.
3. Click one of the following tabs:
  - Level 1:** Keys are assigned on the first key level.
  - Level 2:** Keys are assigned on the second key level.
4. Right-click the function key you want to assign.

A function selection dialog opens.

5. Select the **voice mailbox - open** function.

The current settings for assigning the key are displayed.

6. In the **key name** entry field, enter a name for the key. The following entries are possible:

Up to 16 digits

Digits and characters

Clicking  automatically enters the default name in the entry field.

---

**Note:** The key name is used for printing the label.

---

*Further steps:*

- *Save your configuration before closing.*

### **Configuring the Function Key for Defined Opening of a Voice Mailbox via COMfortel Set**

*Requirements:*

- *COMmander Business or COMmander Basic.2 with inserted COMmander VMF module, COMpact 5010 VoIP with inserted COMpact 2VoIP module, or COMpact 5020 VoIP with inserted COMpact 2VoIP or 6VoIP module*
- *Voice mailbox which is configured in the PBX and assigned to it*
- *An open configuration and knowledge of the required PIN, if necessary*

1. Open the page **function keys > assign function keys**.
2. Only available in installed extension modules: In the telephone displayed at the top left, click the key group in which you would like to assign keys.
3. Click one of the following tabs:
  - Level 1:** Keys are assigned on the first key level.
  - Level 2:** Keys are assigned on the second key level.
4. Right-click the function key you want to assign.

A function selection dialog opens.
5. Select the **voice mailbox - open defined** function.



The current settings for assigning the key are displayed.

6. In the **Number** entry field, enter the number of the voice mailbox which is to be opened via the function key.
7. In the **key name** entry field, enter a name for the key. The following entries are possible:
  - Up to 16 digits
  - Digits and characters

Clicking  automatically enters the default name in the entry field.

---

**Note:** The key name is used for printing the label.

---

*Further steps:*

- *Save your configuration before closing.*

### **Configuring the Function Key for Opening of a Voice Mailbox via the Telephone Menu**

*Requirements:*

- *COMmander Business or COMmander Basic.2 with inserted COMmander VMF module, COMpact 5010 VoIP with inserted COMpact 2VoIP module, or COMpact 5020 VoIP with inserted COMpact 2VoIP or 6VoIP module*
- *Voice mailbox which is configured in the PBX and assigned to it*
- *Knowledge of the telephone, its menu options and the required PIN, if necessary*

1. Press the **menu key** and open the **define keys** menu.
2. Press the **function key** that you would like to assign.
3. Select the desired option:

**First level:** Keys are assigned on the first key level.

**Second level:** Keys are assigned on the second key level.

The list of available functions is displayed.



4. Select the **VMB open** function.

The current settings for assigning the key are shown on the display.

5. Select the kind of key. Press the  **softkey** to switch over between the different kinds of keys.

**general:** Press the key to open a voice mailbox. (No other action is required.)

**defined:** Press the key to open the selected voice mailbox.

6. Press the **softkey**  and select a voice mailbox from the list.
7. Press the **softkey**  and enter a name.
8. Press the  **softkey** to accept the setting.

# Readiness

To enable the voice mailbox to accept calls and record messages, readiness must be enabled.

---

## Switching Readiness On/Off

---

**Note:** You can also switch readiness on and off via remote access.

---

Switching on/off can be done as follows:

- Via the telephone menu

### *Requirements:*

- *COMmander Business or COMmander Basic.2 with inserted COMmander VMF module, COMpact 5010 VoIP with inserted COMpact 2VoIP module, or COMpact 5020 VoIP with inserted COMpact 2VoIP or 6VoIP module*
- *Voice mailbox which is configured in the PBX and assigned to it*
- *Knowledge of the telephone, its menu options and the required PIN, if necessary*

In order to switch readiness on or off, press the **function key** configured for readiness.

Alternatively, proceed as described in the following.

1. Press the **menu key** and open the **voice mailbox > functions > VMB readiness** menu.
2. Select a voice mailbox from the list.
3. Select the desired option:
  - permanently on:** Enables readiness.
  - permanently off:** Disables readiness.

The ● icon indicates the current setting.

---

## Configuring and Operating the Function Key for Readiness

Press the generally assigned key to permanently switch the readiness of a voice mailbox to be selected on or off.

Press the defined and assigned key to switch a previously defined voice mailbox on or off or switch it over.

In addition, when functions are assigned on the first key level, the status of the function is indicated by the corresponding LED.

### LED signalling next to the key:

Green	Readiness is enabled.
Yellow	The readiness of at least one voice mailbox has been switched off (only in case of general assignment). The readiness of the box is switched on, but the permanent configuration is inactive (only in case of defined assignment).
Off	Readiness is disabled.

The configuration can be carried out as follows:

- Via COMfortel Set
- Via the telephone menu

### Configuring the Function Key for Readiness (general) via COMfortel Set

#### *Requirements:*

- *COMmander Business or COMmander Basic.2 with inserted COMmander VMF module, COMpact 5010 VoIP with inserted COMpact 2VoIP module, or COMpact 5020 VoIP with inserted COMpact 2VoIP or 6VoIP module*
- *Voice mailbox which is configured in the PBX and assigned to it*
- *An open configuration and knowledge of the required PIN, if necessary*

1. Open the page **function keys > assign function keys**.
2. Only available in installed extension modules: In the telephone displayed at the top left, click the key group in which you would like to assign keys.
3. Click one of the following tabs:
  - Level 1:** Keys are assigned on the first key level.
  - Level 2:** Keys are assigned on the second key level.

4. Right-click the function key you want to assign.  
A function selection dialog opens.
5. Select the **voice mailbox - readiness** function.  
The current settings for assigning the key are displayed.
6. In the **key name** entry field, enter a name for the key. The following entries are possible:
  - Up to 16 digits
  - Digits and characters

Clicking  automatically enters the default name in the entry field.

---

**Note:** The key name is used for printing the label.

---

*Further steps:*

- *Save your configuration before closing.*

### **Configuring the Function Key for Readiness (defined) via COMfortel Set**

*Requirements:*

- *COMmander Business or COMmander Basic.2 with inserted COMmander VMF module, COMcompact 5010 VoIP with inserted COMcompact 2VoIP module, or COMcompact 5020 VoIP with inserted COMcompact 2VoIP or 6VoIP module*
- *Voice mailbox which is configured in the PBX and assigned to it*
- *An open configuration and knowledge of the required PIN, if necessary*

1. Open the page **function keys > assign function keys**.
2. Click one of the following tabs:
  - Level 1:** Keys are assigned on the first key level.
  - Level 2:** Keys are assigned on the second key level.
3. Right-click the function key you want to assign.  
A function selection dialog opens.
4. Select the **voice mailbox - readiness defined** function.  
The current settings for assigning the key are displayed.

5. In the **Number** entry field, enter the number of the voice mailbox which is to be switched via the function key.
6. In the **kind of switching** list field, select one of the following options:
  - switch on:** Press the key to enable the readiness mode.
  - switch off:** Press the key to disable the readiness mode.
  - switch over:** Press the key to switch the readiness mode on and off.
7. In the **key name** entry field, enter a name for the key. The following entries are possible:
  - Up to 16 digits
  - Digits and characters

Clicking  automatically enters the default name in the entry field.

---

**Note:** The key name is used for printing the label.

---

*Further steps:*





- *Save your configuration before closing.*

### **Configuring the Function Key for Readiness via the Telephone Menu**

*Requirements:*

- *COMmmander Business or COMmmander Basic.2 with inserted COMmmander VMF module, COMpact 5010 VoIP with inserted COMpact 2VoIP module, or COMpact 5020 VoIP with inserted COMpact 2VoIP or 6VoIP module*
- *Voice mailbox which is configured in the PBX and assigned to it*
- *Knowledge of the telephone, its menu options and the required PIN, if necessary*

1. Press the **menu key** and open the **define keys** menu.
2. Press the **function key** that you would like to assign.
3. Select the desired option:
  - First level:** Keys are assigned on the first key level.
  - Second level:** Keys are assigned on the second key level.The list of available functions is displayed.
4. Select the **VMB readiness** function.

5. Select the kind of key. Press the  **softkey** to switch over between the different kinds of keys.
  - general:** If you press the key, one voice mailbox will be switched into readiness mode. (No other action is required.)
  - defined:** If you press the key, the selected voice mailbox will be switched into readiness mode.
6. Press the **softkey**  and select a voice mailbox from the list.
7. Press the **softkey**  and enter a name.
8. Only when the kind of key **defined** has been selected: Select the kind of switching. Press the  **softkey** to switch over between the different kinds of switching.
  - switch off:** Press the key to disable the readiness mode.
  - switch on:** Press the key to enable the readiness mode.
  - switch over:** Press the key to switch the readiness mode on and off.
9. Press the  **softkey** to accept the setting.

## Configuration-Dependent Control

The readiness of the voice mailbox be switched on permanently. In addition, however, there are alternative options. With the help of configuration-dependent control, the voice mailbox can be switched via the PBX configurations, e. g. day-night switching.

---

### Switching the Configuration-Dependent Control On/Off

Switching on/off can be done as follows:

- Via the telephone menu

#### *Requirements:*

- *COMmander Business or COMmander Basic.2 with inserted COMmander VMF module, COMpact 5010 VoIP with inserted COMpact 2VoIP module, or COMpact 5020 VoIP with inserted COMpact 2VoIP or 6VoIP module*
- *Voice mailbox which is configured in the PBX and assigned to it*
- *Configurations made in the PBX*
- *Knowledge of the telephone, its menu options and the required PIN, if necessary*

To enable configuration-dependent control, press a **function Key** configured for configuration-dependent control. To disable onfiguration-dependent control, switch the readiness on.

Alternatively, proceed as described in the following.

1. Press the **menu key** and open the **voice mailbox > functions > VMB config. control** menu.
2. Select a voice mailbox from the list.
3. Press the **✓ softkey** to accept the setting.



---

## Configuring and Operating the Function Key for Configuration-Dependent Control

Press the generally assigned key to enable configuration-dependent control for a voice mailbox, which remains to be selected.

Press the defined and assigned key to enable configuration-dependent control for a previously defined voice mailbox.

In addition, when functions are assigned on the first key level, the status of the function is indicated by the corresponding LED.

### LED signalling next to the key:

Green	Configuration-dependent control is enabled. The permanent configuration is inactive.
Off	Configuration-dependent control is disabled. The permanent configuration is active.

The configuration can be carried out as follows:

- Via COMfortel Set
- Via the telephone menu

### Configuring the Function Key for Configuration-Dependent Control (general) via COMfortel Set

#### *Requirements:*

- *COMmander Business or COMmander Basic.2 with inserted COMmander VMF module, COMpact 5010 VoIP with inserted COMpact 2VoIP module, or COMpact 5020 VoIP with inserted COMpact 2VoIP or 6VoIP module*
- *Voice mailbox which is configured in the PBX and assigned to it*
- *Configurations made in the PBX*
- *An open configuration and knowledge of the required PIN, if necessary*

1. Open the page **function keys > assign function keys**.
2. Only available in installed extension modules: In the telephone displayed at the top left, click the key group in which you would like to assign keys.
3. Click one of the following tabs:
  - Level 1:** Keys are assigned on the first key level.
  - Level 2:** Keys are assigned on the second key level.

4. Right-click the function key you want to assign.  
A function selection dialog opens.
5. Select the **voice mailbox - config. control** function.  
The current settings for assigning the key are displayed.
6. In the **key name** entry field, enter a name for the key. The following entries are possible:
  - Up to 16 digits
  - Digits and characters

Clicking  automatically enters the default name in the entry field.

---

**Note:** The key name is used for printing the label.

---

*Further steps:*

- *Save your configuration before closing.*

### **Configuring the Function Key for Configuration-Dependent Control (defined) via COMfortel Set**

*Requirements:*

- *COMmander Business or COMmander Basic.2 with inserted COMmander VMF module, COMpact 5010 VoIP with inserted COMpact 2VoIP module, or COMpact 5020 VoIP with inserted COMpact 2VoIP or 6VoIP module*
- *Voice mailbox which is configured in the PBX and assigned to it*
- *Configurations made in the PBX*
- *An open configuration and knowledge of the required PIN, if necessary*

1. Open the page **function keys > assign function keys**.
2. Only available in installed extension modules: In the telephone displayed at the top left, click the key group in which you would like to assign keys.
3. Click one of the following tabs:
  - Level 1:** Keys are assigned on the first key level.
  - Level 2:** Keys are assigned on the second key level.
4. Right-click the function key you want to assign.

A function selection dialog opens.

5. Select the **voice mailbox - config. control defined** function.  
The current settings for assigning the key are displayed.
6. In the **Number** entry field, enter the number of the voice mailbox which is to be switched via the function key.
7. In the **key name** entry field, enter a name for the key. The following entries are possible:
  - Up to 16 digits
  - Digits and characters

Clicking  automatically enters the default name in the entry field.

---

**Note:** The key name is used for printing the label.

---

*Further steps:*

- *Save your configuration before closing.*

## **Configuring the Function Key for Configuration-Dependent Control via the Telephone Menu**

*Requirements:*





- *COMmander Business or COMmander Basic.2 with inserted COMmander VMF module, COMpact 5010 VoIP with inserted COMpact 2VoIP module, or COMpact 5020 VoIP with inserted COMpact 2VoIP or 6VoIP module*
- *Voice mailbox which is configured in the PBX and assigned to it*
- *Configurations made in the PBX*
- *Knowledge of the telephone, its menu options and the required PIN, if necessary*

1. Press the **menu key** and open the **define keys** menu.
2. Press the **function key** that you would like to assign.
3. Select the desired option:

**First level:** Keys are assigned on the first key level.

**Second level:** Keys are assigned on the second key level.

The list of available functions is displayed.

4. Select the **VMB config. control** function.
5. Select the kind of key. Press the  **softkey** to switch over between the different kinds of keys.
  - general:** Press the key to switch configuration-dependent control on. (No other action is required.)
  - defined:** Press the key to enable configuration-dependent control for the selected voice mailbox.
6. Press the **softkey**  and select a voice mailbox from the list.
7. Press the **softkey**  and enter a name.
8. Press the  **softkey** to accept the setting.

## Voice Memos

You can use the voice mailbox to save your own voice memos. Up to 250 voice memos including date, time, and length of the recording can be saved in the voice mailbox. The recordings are numbered consecutively, with the last/latest recording assigned the number 1.

You can listen to, edit, and delete voice memos like any other messages.

---

### Configuring and Operating the Function Key for Recording Voice Memos

Press the key while the telephone is in the idle state to start recording a voice memo.

In addition, when functions are assigned on the first key level, the associated LED indicates whether a voice memo is currently being recorded.

#### LED signalling next to the key:

Green	Recording mode
Yellow (blinking)	Connection setup to the voice mailbox
Off	The function is disabled.

The configuration can be carried out as follows:

- Via COMfortel Set
- Via the telephone menu

### Configuring the Function Key for Recording Voice Memos via COMfortel Set

#### Requirements:

- *COMmander Business or COMmander Basic.2 with inserted COMmander VMF module, COMpact 5010 VoIP with inserted COMpact 2VoIP module, or COMpact 5020 VoIP with inserted COMpact 2VoIP or 6VoIP module*
- *Voice mailbox which is configured in the PBX and assigned to it*
- *An open configuration and knowledge of the required PIN, if necessary*

1. Open the page **function keys > assign function keys**.
2. Only available in installed extension modules: In the telephone displayed at the top left, click the key group in which you would like to assign keys.

3. Click one of the following tabs:
  - Level 1:** Keys are assigned on the first key level.
  - Level 2:** Keys are assigned on the second key level.
4. Right-click the function key you want to assign.  
A function selection dialog opens.
5. Select the **voice mailbox - voice memo** function.  
The current settings for assigning the key are displayed.
6. In the **Number** entry field, enter the number of the voice mailbox where you wish to record the voice memos.
7. In the **key name** entry field, enter a name for the key. The following entries are possible:
  - Up to 16 digits
  - Digits and characters

Clicking  automatically enters the default name in the entry field.

---

**Note:** The key name is used for printing the label.

---

*Further steps:*

- *Save your configuration before closing.*

### **Configuring the Function Key for Recording Voice Memos via the Telephone Menu**

*Requirements:*

- *COMmander Business or COMmander Basic.2 with inserted COMmander VMF module, COMpact 5010 VoIP with inserted COMpact 2VoIP module, or COMpact 5020 VoIP with inserted COMpact 2VoIP or 6VoIP module*
- *Voice mailbox which is configured in the PBX and assigned to it*
- *Knowledge of the telephone, its menu options and the required PIN, if necessary*

1. Press the **menu key** and open the **define keys** menu.
2. Press the **function key** that you would like to assign.
3. Select the desired option:



**First level:** Keys are assigned on the first key level.

**Second level:** Keys are assigned on the second key level.

The list of available functions is displayed.

4. Select the **VMB voice memo** function.

The current settings for assigning the key are shown on the display.

5. Press the **softkey**  and select a voice mailbox from the list.
6. Press the **softkey**  and enter a name.
7. Press the **✓ softkey** to accept the setting.

# Distribution of Messages

The messages in a voice mailbox can be distributed to other voice mailboxes.

---

## Configuring and Operating the Function Key for Distributing Messages

Press the generally assigned key after calling a voice mailbox to distribute messages to another voice mailbox, which remains to be selected.

Press the defined and assigned key after calling a voice mailbox to distribute messages to a previously defined voice mailbox. Moreover, you can select whether you want to move or copy your messages.

### LED signalling next to the key:

None

The configuration can be carried out as follows:

- Via COMfortel Set
- Via the telephone menu

## Configuring the Function Key for the General Distribution of Messages via COMfortel Set

*Requirements:*

- *COMmander Business or COMmander Basic.2 with inserted COMmander VMF module, COMpact 5010 VoIP with inserted COMpact 2VoIP module, or COMpact 5020 VoIP with inserted COMpact 2VoIP or 6VoIP module*
- *Voice mailbox which is configured in the PBX and assigned to it*
- *An open configuration and knowledge of the required PIN, if necessary*

1. Open the page **function keys > assign function keys**.
2. Only available in installed extension modules: In the telephone displayed at the top left, click the key group in which you would like to assign keys.
3. Click one of the following tabs:



**Level 1:** Keys are assigned on the first key level.

**Level 2:** Keys are assigned on the second key level.

4. Right-click the function key you want to assign.

A function selection dialog opens.

5. Select the **voice mailbox - distribute messages** function.

The current settings for assigning the key are displayed.

6. In the **key name** entry field, enter a name for the key. The following entries are possible:

Up to 16 digits

Digits and characters

Clicking  automatically enters the default name in the entry field.

---

**Note:** The key name is used for printing the label.

---

*Further steps:*

- *Save your configuration before closing.*

### **Configuring the Function Key for Defined Distribution of Messages via COMfortel Set**

*Requirements:*

- *COMmander Business or COMmander Basic.2 with inserted COMmander VMF module, COMpact 5010 VoIP with inserted COMpact 2VoIP module, or COMpact 5020 VoIP with inserted COMpact 2VoIP or 6VoIP module*
- *Voice mailbox which is configured in the PBX and assigned to it*
- *An open configuration and knowledge of the required PIN, if necessary*

1. Open the page **function keys > assign function keys**.
2. Only available in installed extension modules: In the telephone displayed at the top left, click the key group in which you would like to assign keys.
3. Click one of the following tabs:

**Level 1:** Keys are assigned on the first key level.

**Level 2:** Keys are assigned on the second key level.

4. Right-click the function key you want to assign.  
A function selection dialog opens.
5. Select the **voice mailbox - distribute messages defined** function.  
The current settings for assigning the key are displayed.
6. In the **Number** entry field, enter the number of the voice mailbox to where messages are to be distributed.

---

**Note:** If you have entered your own voice mailbox as number, the messages will be distributed to the archive.

---

7. In the **kind of switching** list field, select one of the following options:
  - move:** Press the key to move messages. The messages in the voice mailbox will be deleted.
  - copy:** Press the key to copy messages. The messages in the voice mailbox remain unchanged.
8. In the **key name** entry field, enter a name for the key. The following entries are possible:
  - Up to 16 digits
  - Digits and characters

Clicking  automatically enters the default name in the entry field.

---

**Note:** The key name is used for printing the label.

---

*Further steps:*

- *Save your configuration before closing.*

### **Configuring the Function Key for Distributing Messages via the Telephone Menu**

*Requirements:*

- *COMmander Business or COMmander Basic.2 with inserted COMmander VMF module, COMpact 5010 VoIP with inserted COMpact 2VoIP module, or COMpact 5020 VoIP with inserted COMpact 2VoIP or 6VoIP module*
- *Voice mailbox which is configured in the PBX and assigned to it*
- *Knowledge of the telephone, its menu options and the required PIN, if necessary*

1. Press the **menu key** and open the **define keys** menu.
2. Press the **function key** that you would like to assign.
3. Select the desired option:
  - First level:** Keys are assigned on the first key level.
  - Second level:** Keys are assigned on the second key level.The list of available functions is displayed.
4. Select the **VMB - distribute messages** function.
5. Select the kind of key. Press the ↻ **softkey** to switch over between the different kinds of keys.
  - general:** Press the key to distribute messages to another voice mailbox. (No other action is required.)
  - defined:** Press the key to distribute messages to the selected voice mailbox.
6. Press the **softkey** ☒ and enter the number of the voice mailbox in the entry field, to where messages are to be distributed.
7. Press the **softkey** ☒ and enter a name.
8. Select whether you want to copy or move the message. Press the ↻ **softkey** to switch over between the two modes.
  - move:** Press the key to move messages. The messages in the voice mailbox will be deleted.
  - copy:** Press the key to copy messages. The messages in the voice mailbox remain unchanged.
9. Press the ✓ **softkey** to accept the setting.

# Announcements

For each assigned voice mailbox you can record announcements via the telephone. You can replay, edit, and delete your own announcements. In addition to the standard announcement from the voice files, maximally 10 own announcements can be stored per voice mailbox.

---



## Create a New Announcement

Announcements can be created, as follows:

- Via the telephone menu



### Requirements:

- *COMmander Business or COMmander Basic.2 with inserted COMmander VMF module, COMpact 5010 VoIP with inserted COMpact 2VoIP module, or COMpact 5020 VoIP with inserted COMpact 2VoIP or 6VoIP module*
- *Voice mailbox which is configured in the PBX and assigned to it*
- *Knowledge of the telephone, its menu options and the required PIN, if necessary*

1. Press the **Menu key** and open the **voice mailbox > settings > edit announc.** menu.
2. Select the voice mailbox from the list for which you want to record the announcement.
3. Press the **softkey**  to record an announcement.
4. Enter the name. The following entries are possible:
  - Up to 16 digits
  - Numbers and characters using the 0...9 keys.
5. Press the **✓ softkey** to save your entry.
6. Press the **softkey**  next to **start of recording** to start recording the announcement.  
The recording proceeds.
7. Record the announcement.
8. Press the **✓ softkey** next to **end of recording** to end recording the announcement.

---

**Note:**

You have the option of recording the announcement again (by selecting the  option) or listening to the announcement that you have recorded (by selecting the  option).

Recordings with a recording time shorter than 3 second are discarded by the telephone.

---

9. Select **store** to save the recorded announcement in the announcement list.

---

## Edit an Existing Announcement



Editing can be carried out as follows:

- Via the telephone menu

*Requirements:*

- *COMmander Business or COMmander Basic.2 with inserted COMmander VMF module, COMpact 5010 VoIP with inserted COMpact 2VoIP module, or COMpact 5020 VoIP with inserted COMpact 2VoIP or 6VoIP module*
- *Voice mailbox which is configured in the PBX and assigned to it*
- *Knowledge of the telephone, its menu options and the required PIN, if necessary*

Proceed as described in the following.



1. Press the **Menu key** and open the **voice mailbox > settings > edit announc.** menu.
2. Select the voice mailbox from the list for which you want to edit an announcement.
3. Scroll to the desired entry.
4. Press the **softkey** .
5. Overwrite the name, if necessary. The following entries are possible:
  - Up to 16 digits
  - Digits and characters
6. Press the **softkey**  to save your entry and start the recording.
7. Press the **softkey**  next to **start of recording** to start recording the announcement.

The recording proceeds.

8. Record the announcement.
9. Press the  **softkey** next to **end of recording** to end recording the announcement.

---

**Note:**

You have the option of recording the announcement again (by selecting the  option) or listening to the announcement that you have recorded (by selecting the  option).

Recordings with a recording time shorter than 3 second are discarded by the telephone.

---

10. Select **store** to save the recorded announcement in the announcement list.

---

## Delete an Existing Announcement



Deleting can be carried out as follows:

- Via the telephone menu

*Requirements:*

- *COMmander Business or COMmander Basic.2 with inserted COMmander VMF module, COMpact 5010 VoIP with inserted COMpact 2VoIP module, or COMpact 5020 VoIP with inserted COMpact 2VoIP or 6VoIP module*
- *Voice mailbox which is configured in the PBX and assigned to it*
- *Knowledge of the telephone, its menu options and the required PIN, if necessary*

Proceed as described in the following.

1. Press the **Menu key** and open the **voice mailbox > settings > edit announc.** menu.
2. Select the voice mailbox from the list for which you want to delete an announcement.
3. Scroll to the desired entry.
4. Press the **softkey** .
5. Press the  **softkey** to confirm the action.

## Switching the Call Information On/Off for New Messages

If call information is switched on for a new message, the subscriber will be informed when the call was received before the message is replayed.

Switching on/off can be done as follows:

- Via the telephone menu

### *Requirements:*

- *COMmander Business or COMmander Basic.2 with inserted COMmander VMF module, COMpact 5010 VoIP with inserted COMpact 2VoIP module, or COMpact 5020 VoIP with inserted COMpact 2VoIP or 6VoIP module*
- *Voice mailbox which is configured in the PBX and assigned to it*
- *Knowledge of the telephone, its menu options and the required PIN, if necessary*

1. Press the **Menu key** and open the **voice mailbox > settings > call information** menu.
2. Select or clear the **call information** check box.
  - Switches call information on.
  - Switches call information off.
3. Press the **✓ softkey** to accept the setting.

---

## Switching the Separator Tone On/Off for New Messages

If the separator tone is switched on for new messages, a tone will be replayed after each message when listening to several new messages. This makes it easier to distinguish the individual messages from each other.

Switching on/off can be done as follows:

- Via the telephone menu

### *Requirements:*

- *COMmander Business or COMmander Basic.2 with inserted COMmander VMF module, COMpact 5010 VoIP with inserted COMpact 2VoIP module, or COMpact 5020 VoIP with inserted COMpact 2VoIP or 6VoIP module*
- *Voice mailbox which is configured in the PBX and assigned to it*

– *Knowledge of the telephone, its menu options and the required PIN, if necessary*

1. Press the **Menu key** and open the **voice mailbox > settings > separator tone** menu.
2. Select or clear the **separator tone** check box.
  - Enables the separator tone.
  - Disables the separator tone.
3. Press the **✓ softkey** to accept the setting.



# Remote Access

Remote access is used to access and operate the voice mailbox from an internal telephone or from an external telephone.

---

## Execute Remote Access

Performing this procedure can be carried out as follows:

- Using a character string on an external telephone
- Using a character string on the internal telephone

### *Requirements:*

- *COMmander Business or COMmander Basic.2 with inserted COMmander VMF module, COMpact 5010 VoIP with inserted COMpact 2VoIP module, or COMpact 5020 VoIP with inserted COMpact 2VoIP or 6VoIP module*
- *Knowledge of the telephone, its menu options and the required PIN, if necessary*
- *Voice mailbox which is configured in the PBX*

1. Call the voice mailbox.

The voice mailbox accepts the call. You hear the configured announcement.

2. Dial \*.

---

**Note:** If the querying internal telephone is the owner/user of the voice mailbox, step 3 will be omitted.

---

3. Enter the **user PIN** or the **PIN for remote access** and dial #.

Remote access is started. You are led through the remote access menu with the help of various announcements.

4. Execute remote access by entering the following digits.

**0:** Opens the Help menu.

**1:** Opens the main menu.

**2:** Replays new messages.

**3:** Replays all of the messages.

**4:** Jumps back to the previous message.

- 5:** Repeats the message currently being replayed.
- 6:** Jumps to the next message.
- 7:** Deletes the message currently being replayed.
- 8:** Ends replay.
- \* **10:** Disables the voice mailbox.
- \* **11:** Enables the voice mailbox.
- \* **20:** Permits recording and exchanging announcements.
- \* **30:** Disables message forwarding.
- \* **31:** Enables message forwarding.
- \* **70:** Deletes all messages and voice memos.
- \* **99:** Records a voice memo.
- Hang-up:** Ends remote access.

---

**Note:** By dialing **9** while a message is being replayed, the telephone number of the caller will be displayed—provided it has been transferred. By pressing the **#** key, you can initiate a callback to the telephone number of the caller.

---

---

## Switching Remote Access On/Off

Switching on/off can be done as follows:

- Via the telephone menu

### *Requirements:*

- *COMmander Business or COMmander Basic.2 with inserted COMmander VMF module, COMpact 5010 VoIP with inserted COMpact 2VoIP module, or COMpact 5020 VoIP with inserted COMpact 2VoIP or 6VoIP module*
- *Knowledge of the telephone, its menu options and the required PIN, if necessary*
- *Voice mailbox which is configured in the PBX and assigned to it*

In order to switch remote access to the voice mailbox on or off, press the **function key** configured for remote access.

Alternatively, proceed as described in the following.

1. Press the **menu key** and open the **voice mailbox > functions > VMB remote access** menu.

2. Select a voice mailbox from the list.
3. Select the desired option:
  - switch on:** Enables the remote access function.
  - switch off:** Disables the remote access function.The ● icon indicates the current setting.
4. Press the ✓ **softkey** to save your entry.

---

## Configuring and Operating the Function Key for Remote Access

Press the generally assigned key to switch the remote access for a voice mailbox to be selected on or off or switch it over.

Press the defined and assigned key to switch the remote access for a defined voice mailbox on or off or switch it over.

In addition, when functions are assigned on the first key level, the status of the function is indicated by the corresponding LED.

### LED signalling next to the key:

Green	Remote access is enabled.
Yellow	The remote access to at least one voice mailbox has been switched off (only in case of general assignment).
Off	Remote access is disabled.

The configuration can be carried out as follows:

- Via COMfortel Set
- Via the telephone menu

### Configuring the Function Key for General Remote Access via COMfortel Set

#### *Requirements:*

- *COMmander Business or COMmander Basic.2 with inserted COMmander VMF module, COMpact 5010 VoIP with inserted COMpact 2VoIP module, or COMpact 5020 VoIP with inserted COMpact 2VoIP or 6VoIP module*
- *Voice mailbox which is configured in the PBX and assigned to it*
- *An open configuration and knowledge of the required PIN, if necessary*

1. Open the page **function keys > assign function keys**.
2. Only available in installed extension modules: In the telephone displayed at the top left, click the key group in which you would like to assign keys.
3. Click one of the following tabs:
  - Level 1:** Keys are assigned on the first key level.
  - Level 2:** Keys are assigned on the second key level.
4. Right-click the function key you want to assign.  
A function selection dialog opens.
5. Select the **voice mailbox - remote access** function.  
The current settings for assigning the key are displayed.
6. In the **key name** entry field, enter a name for the key. The following entries are possible:
  - Up to 16 digits
  - Digits and characters

Clicking  automatically enters the default name in the entry field.

---

**Note:** The key name is used for printing the label.

---

*Further steps:*

- *Save your configuration before closing.*

### **Configuring the Function Key for Defined Remote Access via COMfortel Set**

*Requirements:*

- *COMmander Business or COMmander Basic.2 with inserted COMmander VMF module, COMpact 5010 VoIP with inserted COMpact 2VoIP module, or COMpact 5020 VoIP with inserted COMpact 2VoIP or 6VoIP module*
- *Voice mailbox which is configured in the PBX*
- *An open configuration and knowledge of the required PIN, if necessary*

1. Open the page **function keys > assign function keys**.

2. Only available in installed extension modules: In the telephone displayed at the top left, click the key group in which you would like to assign keys.
3. Click one of the following tabs:
  - Level 1:** Keys are assigned on the first key level.
  - Level 2:** Keys are assigned on the second key level.
4. Right-click the function key you want to assign.  
A function selection dialog opens.
5. Select the **voice mailbox - remote access defined** function.  
The current settings for assigning the key are displayed.
6. In the **Number** entry field, enter the number of the voice mailbox which is to be switched via the function key.
7. In the **kind of switching** list field, select one of the following options:
  - switch off:** Press the key to disable the remote access.
  - switch on:** Press the key to enable the remote access.
  - switch over:** Press the key to switch the remote access on and off.
8. In the **key name** entry field, enter a name for the key. The following entries are possible:
  - Up to 16 digits
  - Digits and characters

Clicking  automatically enters the default name in the entry field.

---

**Note:** The key name is used for printing the label.

---





*Further steps:*

- *Save your configuration before closing.*

## **Configuring the Function Key for Remote Access via the Telephone Menu**

### *Requirements:*

- *COMmander Business or COMmander Basic.2 with inserted COMmander VMF module, COMpact 5010 VoIP with inserted COMpact 2VoIP module, or COMpact 5020 VoIP with inserted COMpact 2VoIP or 6VoIP module*
- *Voice mailbox which is configured in the PBX and assigned to it*
- *Knowledge of the telephone, its menu options and the required PIN, if necessary*

1. Press the **menu key** and open the **define keys** menu.
2. Press the **function key** that you would like to assign.
3. Select the desired option:
  - First level:** Keys are assigned on the first key level.
  - Second level:** Keys are assigned on the second key level.The list of available functions is displayed.
4. Select the **VMB rem. access** function.
5. Select the kind of key. Press the  **softkey** to switch over between the different kinds of keys.
  - general:** Press the key to enable the remote access. (No other action is required.)
  - defined:** Press the key to configure remote access for a selected voice mailbox.
6. Press the **softkey**  and select a voice mailbox from the list.
7. Press the **softkey**  and enter a name.
8. Only when the kind of key **defined** has been selected: Select the kind of switching. Press the  **softkey** to switch over between the different kinds of switching.
  - switch off:** Press the key to disable the remote access.
  - switch on:** Press the key to enable the remote access.
  - switch over:** Press the key to switch the remote access on and off.
9. Press the  **softkey** to accept the setting.

# Message Forwarding

Message forwarding enables the voice mailbox to notify you of new messages even if you are out and about.

---

## Switching Message Forwarding On/Off

Switching on/off can be done as follows:

- Via the telephone menu

### *Requirements:*

- *COMmander Business or COMmander Basic.2 with inserted COMmander VMF module, COMpact 5010 VoIP with inserted COMpact 2VoIP module, or COMpact 5020 VoIP with inserted COMpact 2VoIP or 6VoIP module*
- *Knowledge of the telephone, its menu options and the required PIN, if necessary*
- *Voice mailbox which is configured in the PBX and assigned to it*
- *The destination for message forwarding of the voice mailbox configured in the PBX*

In order to switch message forwarding on or off, press the **function key** configured for message forwarding.

Alternatively, proceed as described in the following.

1. Press the **menu key** and open the **voice mailbox > functions > VMB forwarding** menu.
2. Select a voice mailbox from the list.
3. Select the desired option:
  - switch on:** Enables message forwarding.
  - switch off:** Disables message forwarding.The ● icon indicates the current setting.
4. Press the ✓ **softkey** to save your entry.

---

## Configuring and Operating the Function Key for Message Forwarding

Press the generally assigned key to switch the message forwarding for a voice mailbox to be selected on or off or switch it over.

Press the defined and assigned key to switch message forwarding for a defined voice mailbox on or off or switch it over.

In addition, when functions are assigned on the first key level, the status of the function is indicated by the corresponding LED.

### LED signalling next to the key:

Green	Message forwarding is enabled.
Yellow	The message forwarding for at least one voice mailbox has been switched off (only in case of general assignment).
Off	Message forwarding is disabled.

The configuration can be carried out as follows:

- Via COMfortel Set
- Via the telephone menu

### Configuring the Function Key for General Message Forwarding via COMfortel Set

#### *Requirements:*

- *COMmander Business or COMmander Basic.2 with inserted COMmander VMF module, COMpact 5010 VoIP with inserted COMpact 2VoIP module, or COMpact 5020 VoIP with inserted COMpact 2VoIP or 6VoIP module*
- *An open configuration and knowledge of the required PIN, if necessary*
- *Voice mailbox which is configured in the PBX and assigned to it*
- *The destination for message forwarding of the voice mailbox configured in the PBX*

1. Open the page **function keys > assign function keys**.
2. Only available in installed extension modules: In the telephone displayed at the top left, click the key group in which you would like to assign keys.
3. Click one of the following tabs:
  - Level 1:** Keys are assigned on the first key level.
  - Level 2:** Keys are assigned on the second key level.
4. Right-click the function key you want to assign.



A function selection dialog opens.

5. Select the **voice mailbox - message forwarding** function.

The current settings for assigning the key are displayed.

6. In the **key name** entry field, enter a name for the key. The following entries are possible:

Up to 16 digits

Digits and characters

Clicking  automatically enters the default name in the entry field.

---

**Note:** The key name is used for printing the label.

---

*Further steps:*

- *Save your configuration before closing.*

### **Configuring the Function Key for Defined Message Forwarding via COMfortel Set**

*Requirements:*

- *COMmander Business or COMmander Basic.2 with inserted COMmander VMF module, COMpact 5010 VoIP with inserted COMpact 2VoIP module, or COMpact 5020 VoIP with inserted COMpact 2VoIP or 6VoIP module*
- *An open configuration and knowledge of the required PIN, if necessary*
- *Voice mailbox which is configured in the PBX and assigned to it*
- *The destination for message forwarding of the voice mailbox configured in the PBX*

1. Open the page **function keys > assign function keys**.
2. Only available in installed extension modules: In the telephone displayed at the top left, click the key group in which you would like to assign keys.
3. Click one of the following tabs:
  - Level 1:** Keys are assigned on the first key level.
  - Level 2:** Keys are assigned on the second key level.
4. Right-click the function key you want to assign.

A function selection dialog opens.

5. Select the **voice mailbox - message forwarding defined** function.  
The current settings for assigning the key are displayed.
6. In the **Number** entry field, enter the number of the voice mailbox which is to be switched via the function key.
7. In the **kind of switching** list field, select one of the following options:
  - switch off**: Press the key to disable message forwarding.
  - switch on**: Press the key to enable message forwarding.
  - switch over**: Press the key to switch message forwarding on and off.
8. In the **key name** entry field, enter a name for the key. The following entries are possible:
  - Up to 16 digits
  - Digits and characters

Clicking  automatically enters the default name in the entry field.

---

**Note:** The key name is used for printing the label.

---

*Further steps:*

- *Save your configuration before closing.*

### **Configuring Function Key for Message Forwarding via the Telephone Menu**

*Requirements:*





- *COMmander Business or COMmander Basic.2 with inserted COMmander VMF module, COMpact 5010 VoIP with inserted COMpact 2VoIP module, or COMpact 5020 VoIP with inserted COMpact 2VoIP or 6VoIP module*
- *Knowledge of the telephone, its menu options and the required PIN, if necessary*
- *Voice mailbox which is configured in the PBX and assigned to it*
- *The destination for message forwarding of the voice mailbox configured in the PBX*

1. Press the **menu key** and open the **define keys** menu.
2. Press the **function key** that you would like to assign.
3. Select the desired option:

**First level:** Keys are assigned on the first key level.

**Second level:** Keys are assigned on the second key level.

The list of available functions is displayed.

4. Select the **VMB forwarding** function.
5. Select the kind of key. Press the  **softkey** to switch over between the different kinds of keys.
  - general:** Press the key to enable message forwarding. (No other action is required.)
  - defined:** Press the key to configure message forwarding for a selected voice mailbox.
6. Press the **softkey**  and select a voice mailbox from the list.
7. Press the **softkey**  and enter a name.
8. Only when the kind of key **defined** has been selected: Select the kind of switching. Press the **softkey**  to switch over between the different kinds of switching.
  - switch off:** Press the key to disable message forwarding.
  - switch on:** Press the key to enable message forwarding.
  - switch over:** Press the key to switch message forwarding on and off.
9. Press the  **softkey** to accept the setting.

# Substitute Function

If the substitute function is switched on, the caller can be connected with the substitute instead of leaving a message on the voice mailbox. For this purpose, the caller dials "1" during the announcement or recording phase.

You have to include this information ("You can reach my substitute by dialling the digit 1...") into the announcement yourself by recording it via an own announcement.

---

## Switching the Substitute Function On/Off

Switching on/off can be done as follows:

- Via the telephone menu

### *Requirements:*

- *COMmander Business or COMmander Basic.2 with inserted COMmander VMF module, COMpact 5010 VoIP with inserted COMpact 2VoIP module, or COMpact 5020 VoIP with inserted COMpact 2VoIP or 6VoIP module*
- *Knowledge of the telephone, its menu options and the required PIN, if necessary*
- *Voice mailbox which is configured in the PBX and assigned to it*
- *The substitute function configured in the PBX for the voice mailbox*
- *Recorded announcement for the voice mailbox (see the manual for the PBX)*

In order to switch the substitute function on or off, press the **function key** configured for the substitute function.

Alternatively, proceed as described in the following.

1. Press the **menu key** and open the **voice mailbox > functions > VMB substitute** menu.
2. Select a voice mailbox from the list.
3. Select the desired option:
  - switch on:** Enables the substitute function.
  - switch off:** Disables the substitute function.The ● icon indicates the current setting.
4. Enter the destination number of the substitute. The following entries are possible:

Up to 32 digits

Digits and the characters \* and #

---

**Important:** Enter telephone numbers exactly as when dialling, for example, always enter external telephone numbers with a leading exchange line access number "0". (exception: direct exchange access).

---

5. Press the  **softkey** to save your entry.

---

## Configuring and Operating the Function Key for the Substitute Function

Press the generally assigned key to switch the substitute function for a voice mailbox to be selected on or off or switch it over.

Press the defined and assigned key to switch the substitute function for a previously defined voice mailbox on or off or switch it over.

In addition, when functions are assigned on the first key level, the status of the function is indicated by the corresponding LED.

### LED signalling next to the key:

Green	The substitute function is enabled.
Yellow	The substitute function for at least one voice mailbox has been switched off (only in case of general assignment).
Off	The substitute function is disabled.

The configuration can be carried out as follows:

- Via COMfortel Set
- Via the telephone menu

## **Configuring the Function Key for the General Substitute Function via COMfortel Set**

### *Requirements:*

- *COMmander Business or COMmander Basic.2 with inserted COMmander VMF module, COMpact 5010 VoIP with inserted COMpact 2VoIP module, or COMpact 5020 VoIP with inserted COMpact 2VoIP or 6VoIP module*
- *Voice mailbox which is configured in the PBX and assigned to it*
- *The substitute function configured in the PBX for the voice mailbox*
- *An open configuration and knowledge of the required PIN, if necessary*
- *Recorded announcement for the voice mailbox (see the manual for the PBX)*

1. Open the page **function keys > assign function keys**.
2. Only available in installed extension modules: In the telephone displayed at the top left, click the key group in which you would like to assign keys.
3. Click one of the following tabs:
  - Level 1:** Keys are assigned on the first key level.
  - Level 2:** Keys are assigned on the second key level.
4. Right-click the function key you want to assign.  
A function selection dialog opens.
5. Select the **voice mailbox - substitute** function.  
The current settings for assigning the key are displayed.
6. In the **key name** entry field, enter a name for the key. The following entries are possible:
  - Up to 16 digits
  - Digits and characters

Clicking  automatically enters the default name in the entry field.

---

**Note:** The key name is used for printing the label.

---

### *Further steps:*

- *Save your configuration before closing.*

## **Configuring the Function Key for the Defined Substitute Function via COMfortel Set**

### *Requirements:*

- *COMmander Business or COMmander Basic.2 with inserted COMmander VMF module, COMpact 5010 VoIP with inserted COMpact 2VoIP module, or COMpact 5020 VoIP with inserted COMpact 2VoIP or 6VoIP module*
- *Voice mailbox which is configured in the PBX and assigned to it*
- *The substitute function configured in the PBX for the voice mailbox*
- *An open configuration and knowledge of the required PIN, if necessary*
- *Recorded announcement for the voice mailbox (see the manual for the PBX)*

1. Open the page **function keys > assign function keys**.
2. Only available in installed extension modules: In the telephone displayed at the top left, click the key group in which you would like to assign keys.
3. Click one of the following tabs:
  - Level 1:** Keys are assigned on the first key level.
  - Level 2:** Keys are assigned on the second key level.
4. Right-click the function key you want to assign.  
A function selection dialog opens.
5. Select the **voice mailbox - substitute defined** function.  
The current settings for assigning the key are displayed.
6. In the **Number** entry field, enter the number of the voice mailbox for which you want to configure this function.
7. In the **kind of switching** list field, select one of the following options:
  - switch off:** Press the key to disable the substitute function.
  - switch on:** Press the key to enable the substitute function.
  - switch over:** Press the key to switch the substitute function on and off.
8. Enter the number in the **number of substitute** entry field. The following entries are possible:
  - Up to 24 digits
  - Digits and the characters \* and #
9. In the **key name** entry field, enter a name for the key. The following entries are possible:

Up to 16 digits

Digits and characters

Clicking  automatically enters the default name in the entry field.

---

**Note:** The key name is used for printing the label.

---

*Further steps:*

- *Save your configuration before closing.*

### **Configuring the Function Key for the Substitute Function via the Telephone Menu**

*Requirements:*

- *COMmander Business or COMmander Basic.2 with inserted COMmander VMF module, COMpact 5010 VoIP with inserted COMpact 2VoIP module, or COMpact 5020 VoIP with inserted COMpact 2VoIP or 6VoIP module*
- *Voice mailbox which is configured in the PBX and assigned to it*
- *The substitute function configured in the PBX for the voice mailbox*
- *Knowledge of the telephone, its menu options and the required PIN, if necessary*
- *Recorded announcement for the voice mailbox (see the manual for the PBX)*

1. Press the **menu key** and open the **define keys** menu.

2. Press the **function key** that you would like to assign.

3. Select the desired option:

**First level:** Keys are assigned on the first key level.

**Second level:** Keys are assigned on the second key level.

The list of available functions is displayed.



4. Select the **VMB substitute** function.

5. Select the kind of key. Press the  **softkey** to switch over between the different kinds of keys.

**general:** Press the key to enable the substitute function. (No other action is required.)

**defined:** Press the key to configure the substitute function for a selected voice mailbox.



6. Press the **softkey**  and select a voice mailbox from the list.
7. Press the **softkey**  and enter a name.
8. Press the **softkey**  next to **VMB substitute**.
9. Enter the number of the substitute. The following entries are possible:



Up to 32 digits

Digits and the characters \* and #

---

**Important:** Enter telephone numbers exactly as when dialling, for example, always enter external telephone numbers with a leading exchange line access number "0". (exception: direct exchange access).

---

10. Only when the kind of key **defined** has been selected: Select the kind of switching. Press the  **softkey** to switch over between the different kinds of switching.
  - switch off:** Press the key to disable the substitute function.
  - switch on:** Press the key to enable the substitute function.
  - switch over:** Press the key to switch the substitute function on and off.
11. Press the  **softkey** to accept the setting.

# Service and Maintenance

This section describes useful service functions, among other things. This includes deleting, saving and restoring data in the case of a malfunction and the need to exchange the telephone or PBX.

## Topics

- [Firmware Update \(page 547\)](#)
- [Data Backup \(page 552\)](#)
- [Selecting a PBX \(page 558\)](#)
- [Initiating PBX Synchronisation \(page 559\)](#)
- [Deleting Data \(page 560\)](#)
- [Diagnostic Functions \(page 563\)](#)

# Firmware Update

When firmware is updated, errors are corrected and new features are installed. To do this, the device establishes a connection to a server in order to download the most current firmware (the device settings remain intact). Except for the charges for the required server connection, the update is free of charge.

---

## Firmware Update Variants

There are various options for carrying out a firmware update. The variants are differentiated as follows:

### Manual Firmware Update

When a manual firmware update is carried out, a file (\*.rom) is uploaded into the telephone via COMfortel Set thereby saving the new firmware in the telephone.

### Instant Firmware Update via the Update Server

When an instant firmware update is activated via the update server, the firmware update is initiated automatically. After a connection to the update server has been established, the server sends the latest firmware to telephone.

---

## Initiating Manual Firmware Update

Initiation can be carried out as follows:

- Via COMfortel Set

### *Requirements:*

- *An existing PC connection configured correctly in COMfortel Set to a PC interface on the PBX or another connected system telephone*
- *Knowledge of the required PIN*
- *The firmware file saved on the hard drive (\*.rom)*

---

**Note:** You can download the firmware file from the support pages at the Auerswald web site (Internet address: [www.auerswald.de](http://www.auerswald.de)).

---

1. Open the menu **Service > Write firmware into the telephone....**

A file selection dialogue opens.

2. Select the file you want (\*.rom) and click **Open** (this text is dependent on the operating system used).

The **Connection routes** dialogue with the devices connected via the interface configured above opens.

3. Select the telephone on which you would like to save the firmware and click **OK**.

The **PIN entry** dialogue opens.

---

**Note:** For operation on the PBXs COMpact 3000, COMpact 5010 VoIP, COMpact 5020 VoIP, COMmander Basic.2 and COMmander Business, access to the telephone is only possible via the 6-digit PIN assigned in the PBX. In this case, you need to first select which PIN you would like to enter based on the authority level: the Admin PIN, one of the subadmin PINs or the user PIN that belongs to the telephone.

---

4. Enter the associated PIN and click **OK**.

The firmware is saved on the telephone. This may take a while.

*Further steps:*

- *In order to use new features after a firmware update, you normally need a new version of the operating manual. This is available per download from the support pages at the Auerswald website (Internet address: [www.auerswald.de](http://www.auerswald.de)).*
- *In order to use the new features after a firmware update of the telephone, an update of the PBX firmware is often necessary. See the PBX manual.*

---

## Configuring Update Server Number

The telephone number for the update server must be configured for instant firmware updates via the update server. The factory settings are already configured with the telephone number of the update server. However, if this is not the case or if you would like to change the telephone number, proceed as described in the following.

The configuration can be carried out as follows:

- Via COMfortel Set

### *Requirements:*

- *An open configuration and the required PIN, if necessary*

---

**Note:** If you change the telephone number of the update server via the telephone menu under **settings > synchronisation > firmware update**, a firmware update is carried out immediately afterwards.

---

1. Open the page **Settings/functions > Basic settings**.
2. In the **Update server telephone number** entry field enter the telephone number of the update server.

### *Further steps:*

- *Save your configuration before closing.*

---

## Initiating Instant Firmware Update via Update Server

Initiation can be carried out as follows:

- Via the telephone menu

### *Requirements:*

- *Knowledge of the telephone, its menu options and the required PIN, if necessary*
- *The PBX connected to ISDN connection*

1. Press the **menu key** and open the menu **settings > synchronisation > firmware update**.

The address of the update server is displayed. If necessary, change the address of the update server.

2. Press the **✓ softkey**.

The firmware update is performed. After this, a message appears in the display indicating whether the update was successful.

3. Press the **✓ softkey**.

*Further steps:*

- *Once you have carried out the firmware update, you can distribute the new firmware version from this telephone to all the other system telephones of the same model connected to the PBX. If there are system telephones of a different model (COMfortel 1500 and COMfortel 2500), an additional manual firmware update has to be done.*
- *In order to use new features after a firmware update, you normally need a new version of the operating manual. This is available per download from the support pages at the Auerswald website (Internet address: [www.auerswald.de](http://www.auerswald.de)).*
- *In order to use the new features after a firmware update of the telephone, an update of the PBX firmware is often necessary. See the PBX manual.*

---

## Distributing Firmware

A new version of firmware can be distributed from a system telephone to all of the other system telephones of the same model connected to the PBX.

The distribution can be carried out as follows:

- Via the telephone menu

*Requirements:*

- *Knowledge of the telephone, its menu options and the required PIN, if necessary*
- *Existing new firmware on the distributing system telephone*

1. Press the **menu key** and open the menu **settings > synchronisation > distr. firmware > immediately**.

The firmware is distributed. During the distribution process, **Server Mode** is displayed on the display panel of the distributing system telephone. It is not possible to use the system telephone during this process.

## Saving Firmware as File on PC

The saving procedure can be carried out as follows:

- Via COMfortel Set

### *Requirements:*

- *An existing PC connection configured correctly in COMfortel Set to a PC interface on the PBX or another connected system telephone*
- *Knowledge of the required PIN*

1. Open the menu **Service > Read firmware from the telephone....**

A file location dialogue opens.

2. Select the directory in which you would like to save the file.

3. Enter a filename with the ending **.rom** and click **Save** (this text is dependent on the operating system used).

The **Connection routes** dialogue with the devices connected via the interface configured above opens.

4. Select the telephone whose firmware you would like to read and click **OK**.

The **PIN entry** dialogue opens.

---

**Note:** For operation on the PBXs COMpact 3000, COMpact 5010 VoIP, COMpact 5020 VoIP, COMmander Basic.2 and COMmander Business, access to the telephone is only possible via the 6-digit PIN assigned in the PBX. In this case, you need to first select which PIN you would like to enter based on the authority level: the Admin PIN, one of the subadmin PINs or the user PIN that belongs to the telephone.

---

5. Enter the associated PIN and click **OK**.

The firmware is read out the telephone and saved on the PC. This may take a while.

# Data Backup

During a data backup, a backup file is created either automatically or manually. This file contains the configuration and/or other data and settings for the telephone. The areas to be backed up can be configured separately.

---

## Data Backup on PC

During data backup on a PC, a backup file containing telephone data is created and saved on the PC via COMfortel Set. If necessary, this backup file can be uploaded back into the same system telephone or to another. The required areas (for example, configuration or telephone book) can be selected. The following areas can be selected:

- MSN (your own internal number)
- Configuration
  - Settings (settings configured in the settings menu (except blocking))
  - Functions (settings configured in the functions menu)
  - Function keys (function key definitions)
  - Project numbers (existing project lists)
  - Scheduled call list (entries in the scheduled call list)
  - Specific information (for example, charges for last call, charge totals)
- Ringer rhythms/melodies (customised ringer rhythms)
- Local telephone book (entries in the local telephone book)
- Answering machine settings (settings configured in the answering machine menu)
- Call list (entries in the call list)
- Caller list (entries in the caller list)
- Redial list (entries in the redial list)

### **Backing up Current Data in a File on the PC**

The backup can be carried out as follows:

- Via COMfortel Set



*Requirements:*

- *An existing PC connection configured correctly in COMfortel Set to a PC interface on the PBX or another connected system telephone*
- *Knowledge of the required PIN*

1. Open the menu **Service > Create backup file....**

The **Connection routes** dialogue with the devices connected via the interface configured above opens.

2. Select the telephone whose firmware you would like to read out and click **OK**.

The **PIN entry** dialogue opens.

---

**Note:** For operation on the PBXs COMpact 3000, COMpact 5010 VoIP, COMpact 5020 VoIP, COMmander Basic.2 and COMmander Business, creating a backup file for the telephone is only possible using a 6-digit admin PIN assigned in the PBX.

---

3. Enter the associated PIN and click **OK**.

The data is read out from the telephone. This may take a while.

A file location dialogue opens.

4. Select the directory in which you would like to save the file.

5. Enter a filename with the ending **.cfi** and click **Save** (this text is dependent on the operating system used).

### **Saving Data Backups on PC to Telephone**

The saving procedure can be carried out as follows:

- Via COMfortel Set

*Requirements:*

- *An existing PC connection configured correctly in COMfortel Set to a PC interface on the PBX or another connected system telephone*
- *Knowledge of the required PIN*
- *Backup file (\*.cfi) on the hard disk*

1. Open the menu **Service > Accept backup data...**

A file selection dialogue opens.

2. Select the file (\*.cfi) you want and click **Open** (this text is dependent on the operating system used).

The **Connection routes** dialogue with the devices connected via the interface configured above opens.

3. Select the telephone on which you would like to save the backup file and click **OK**.

The **PIN entry** dialogue opens.

---

**Note:** For operation on the PBXs COMpact 3000, COMpact 5010 VoIP, COMpact 5020 VoIP, COMmander Basic.2 and COMmander Business, saving a backup file is only possible using the 6-digit admin PIN assigned in the PBX.

---

4. Enter the associated PIN and click **OK**.

A dialogue for selecting the data to be transferred opens.

5. Select or clear the check box for the files to be transferred.

- The corresponding data of the backup file is saved on the telephone.
- The corresponding data of the backup file is not saved on the telephone.

- a) When the check box **MSN (own internal number)** has been selected: you may enter another MSN in the **MSN (own internal number)** entry field. This MSN is then be saved on the telephone instead of the MSN in the backup file.
- b) If one or more of the check boxes **Calls list**, **Caller list** and/or **Redial list** are selected: Enter the corresponding PIN in the **PIN of the backup file** entry field.

---

**Note:** For operation on the PBXs COMpact 3000, COMpact 5010 VoIP, COMpact 5020 VoIP, COMmander Basic.2 and COMmander Business, it is only possible to save the lists using the 6-digit user PIN assigned in the PBX.

---

6. Select or clear the **Delete not selected areas?** check box.

- Data that is not to be saved on the telephone and which is marked with an asterisk (\*) are deleted from the target telephone.
- Data that is not to be saved on the telephone remains on the destination telephone.

7. Click **OK**.

The backup data is saved on the telephone. This may take a while.

---

**Note:** If the destination telephone has fewer resources than the source telephone, the corresponding data (for example, telephone book, key definition on COMfortel xtension30, ringer melodies) cannot be transferred. The telephone book in a COMfortel 2500, for instance, cannot be transferred to a COMfortel 1500.

---

---

## Data Backup to SD Card

---

**Note:** Data backup to the SD card is only possible on a COMfortel 2500 with an SD card inserted.

---

The backup function can be used to either manually or automatically back up the telephone data on the telephone SD card.

A maximum of 14 complete or partial backups can be saved on the SD card. If this number is exceeded, the oldest backup is overwritten.

A directory for each backup is created on the SD card; a file is saved for every partial backup. The files can be backed up from the SD card to a PC.

Instead of a total backup of the telephone, a partial area can be selected for backup. The following areas can be selected:

- Caller list (entries in the caller list)
- Settings (settings configured in the settings menu (except blocking))
- Functions (settings configured in the functions menu)
- Function keys (function key definitions)
- Call list (entries in the call list)
- Ringer rhythms (customised ringer rhythms)
- Project number (existing project list)
- Blocking (blocking settings configured in the settings menu)
- Local telephone book (entries in the local telephone book)
- Scheduled call list (entries in the scheduled call list)
- Redial list (entries in the redial list)

### **Configuring Areas for Data Backup on SD Card**

The configuration can be made as follows:

- Via the telephone menu

#### *Requirements:*

- Knowledge of the telephone, its menu options and the required PIN, if necessary
- An SD card inserted in the SD slot

1. Press the **menu key** and open the menu **settings > Backup > configuration**.
2. Select or clear the check box for the areas in question.
  - The area in question becomes a part of the data backup.
  - The area in question does not become a part of the data backup.
3. Press the **✓ softkey** to accept the setting.

### **Backing up Current Data on SD Card**

The backup can be carried out as follows:

- Via the telephone menu

#### *Requirements:*

- Knowledge of the telephone, its menu options and the required PIN, if necessary
- An SD card inserted in the SD slot

- Press the **menu key** and open the menu **settings > backup > CF2500 -> SD**.

The data is backed up in the **BACKUP** directory on the SD card.

### **Saving SD Card Data Backups on Telephone**

The SD card data also contain the MSN. They can be saved on the telephone with or without the MSN.

The saving procedure can be carried out as follows:

- Via the telephone menu

*Requirements:*

- Knowledge of the telephone, its menu options and the required PIN, if necessary
- An SD card inserted in the SD slot

1. Proceed as follows:

- If you also want to save the MSN on the telephone, press the **menu key** and open the menu **settings > Backup > SD -> CF2500**.
- If you want to save the data on the telephone without the MSN, press the **menu key** and open the menu **settings > Backup > w/o MSN -> CF**.

The date and time of the data backup are displayed.

2. Select the desired data backup and press the **✓ softkey**.

The data is saved on the telephone.

### **Switching Regular Automatic Data Backup On/Off**

If automatic data backup is switched on, data will be backed up every day at midnight (as soon as the telephone goes into the idle state).

Switching this on/off can be done as follows:

- Via the telephone menu

*Requirements:*

- Knowledge of the telephone, its menu options and the required PIN, if necessary
- An SD card inserted in the SD slot

1. Press the **menu key** and open the menu **settings > Backup > automatic** .

2. Select or clear the **automatic** check box.

- Enables automatic data backup.
- Disables automatic data backup.

3. Press the **✓ softkey** to accept the setting.

## Selecting a PBX

The configuration of the telephone is dependent on the PBX that it is run on. In order to preconfigure a telephone for operation in another PBX (for example, for service calls), configure the system to be valid ahead of time. Ignore the error message and configure the desired presettings using the COMfortel Set. If you select another PBX instead of COMpact 3000, COMpact 5010 VoIP, COMpact 5020 VoIP, COMmander Basic.2 or COMmander Business (or vice versa), the existing configuration is irrevocably deleted.

The selection can be carried out as follows:

- Via the telephone menu

### *Requirements:*

– *Knowledge of the telephone, its menu options and the required PIN, if necessary*

1. Press the **menu key** and open the menu **settings > synchronisation > select PBX**.

The ● icon indicates the current setting.

2. Select the desired PBX.

The telephone restarts.

---

**Note:** If the wrong PBX is selected, this is detected and an error message is displayed. If the setting for a wrong PBX is made on purpose for service reasons, the error message must be ignored.

---

## Initiating PBX Synchronisation

If necessary, you can initiate a complete data synchronisation with the PBX.

Initiation can be carried out as follows:

- Via the telephone menu

### *Requirements:*

– *Knowledge of the telephone, its menu options and the required PIN, if necessary*

- Press the **menu key** and open the menu **settings > synchronisation > sync. with PBX**.

Data synchronisation is performed with the PBX.

## Deleting Data

You have the option of deleting individual pieces of data saved in the telephone. This includes resetting the telephone back to factory settings as well as deleting charges and personal data.

---

### Restoring Factory Setting

The restoration can be carried out as follows:

- Via the telephone menu

#### *Requirements:*

– *Knowledge of the telephone, its menu options and the required PIN, if necessary*

1. Press the **menu key** and enter **#201** via the keypad.
2. Press the **✓ softkey** to confirm the action.

---

**Note:** When operated on one of the PBXs COMpact 3000, COMpact 5010 VoIP, COMpact 5020 VoIP, COMmander Basic.2 or COMmander Business, the PINs remain because the PINs of the PBX are used. When operated on one of the other PBXs the user PIN will be deleted.

---

#### *Further steps:*

- *Put the telephone back into operation. If necessary, refer to the commissioning instructions.*
- *Create a new configuration or reinstall the previously saved configuration in the telephone.*



## Deleting Charges

The total charges accumulated since the last operation are displayed in the **Information** menu. In order to view the charge expenses accumulated during specified time intervals, you can delete the total charges accumulated from time to time. If you would like to prevent anyone from seeing the charges for your last call, you can also delete that entry.

Deleting can be carried out as follows:

- Via the telephone menu

### *Requirements:*

– *Knowledge of the telephone, its menu options and the required PIN, if necessary*

1. Press the **menu key** and open the menu **functions > del.call charge**.
2. Select one of the following options:
  - most recent call:** Deletes the charges of the last call.
  - call charge total:** Deletes all of the charges accumulated so far.
3. Press the **✓ softkey** to confirm the action.

---

**Note:** Neither the total charges recorded in the PBX nor the call data sets are affected by the delete operation.

---

---

## Deleting Personal Data

You can delete your personal data, for example, telephone numbers, messages and settings based on the function.

Deleting can be carried out as follows:

- Via the telephone menu

## **Deleting Personal Data via Telephone Menu**

### *Requirements:*

– Knowledge of the telephone, its menu options and the required PIN, if necessary

1. Press the **menu key** and open the menu **functions > delete data**.
2. Select one of the following options:
  - caller list** Deletes all of the entries in the caller list.
  - calls list:** Deletes all of the entries in the calls list.
  - redial list:** Deletes all of the entries in the redial list.
  - phone book:** Deletes all of the entries in the telephone book on the telephone.
  - function keys:** Deletes all of the function keys that are not blocked.
  - scheduled call list:** Deletes all of the entries in the scheduled call list.
  - TAM list:** Deletes all of the entries in the answering machine list.
  - TAM voice memo:** Deletes all of the entries in the list of voice memos.
  - all:** Deletes all of the data listed here.
3. Press the **✓ softkey** to confirm the action.

# Diagnostic Functions

Diagnostic functions can be used to carry out the following tests:

- Line check (BERT)
- Determining the services available in the PBX
- Checking the quality of the SD card (COMfortel 2500 only)

---

## Performing Line Check (BERT)

*Requirements:*

– Knowledge of the telephone, its menu options and the required PIN, if necessary

1. Press the **menu key** and open the menu **diagnosis > ISDN > line test (BERT)**.
2. Select one of the following options:
  - internal:** Performs the line check to an internal subscriber.
  - external:** Performs the line check to an external subscriber.
3. Only when the option **internal** is selected: Enter the MSN of the subscriber to whom the line check is to be performed.
4. Only when the option **external** is selected: Enter the external destination number of the subscriber to whom the line check is to be performed. The following entries are possible:
  - Up to 40 digits
  - Digits and the characters \* and #

---

**Important:** Enter telephone numbers exactly as when dialling, for example, external telephone numbers always with a leading exchange line access number. (exception: direct exchange access). The default exchange line access number on the PBX is "0" in the factory settings; however, this can be changed for several PBXs (see the PBX manual).

---

5. Press the **✓ softkey**.

6. Select one of the following options:

**1 min:** The line check (Bit Error Rate Test) is carried out in compliance with ITU-T o.150 and o.151 for one minute.

**15 min:** The line check (Bit Error Rate Test) is carried out in compliance with ITU-T o.150 and o.151 for 15 minutes.

7. Press the **✓ softkey**.

The line check (BERT) is carried out.

The firmware update is carried out. Afterwards, a message is displayed which shows if the line check was successful or if errors were found. The limit of error is  $10^{-6}$ .

---

## Determining the services on the PBX

### Requirements:

- Knowledge of the telephone, its menu options and the required PIN, if necessary

1. Press the **menu key** and open the menu **diagnosis > ISDN > supp. serv. test**.
2. Press the **✓ softkey**.

The services test is started. All available services in the PBX are then marked by  .

---

## Checking Quality of SD Card (COMfortel 2500 Only)

### Requirements:

- Knowledge of the telephone, its menu options and the required PIN, if necessary
- An SD card inserted in the SD slot

- Press the **Menu key** and open the menu **diagnosis > SD card > test card**.

The quality of the SD card is checked.

# Glossary

The glossary contains an alphabetical list of the functions and terminology used accompanied by short explanations.

There is also an index of abbreviations.

## Topics

- [Terminology and Functions \(page 566\)](#)
- [Abbreviations \(page 580\)](#)

# Terminology and Functions

A B C D E F G H I L M P Q R S T V W

---

## A

### **Answering Machine List**

The telephone answering machine list can save up to 250 messages and call recordings made on the answering machine. The list also includes the date and time of the recording as well as the telephone number of the caller/communication partner. The recordings are numbered consecutively, with the last/latest recording assigned the number 1.

You can call someone who has called you directly from the answering machine list.

The LED above the message key indicates whether entries are present on the answering machine list.

### **Automatic Call Acceptance**

Automatic call acceptance facilitates headset operation at call centers or on hotlines. An incoming call is automatically accepted after a configured amount of time. Call acceptance is signalled by an attention tone.

---

## B

### **Boss/Secretary Function**

The boss/secretary function protects the boss telephone from direct calls by rerouting them to the secretary. The most important difference from call forwarding is that the boss telephone can still be called from the secretary telephone and the secretary can still transfer important calls to the boss telephone.

## C

### **Call Deblocker (Incoming) – VIP Numbers**

If you would still like to allow specific people to call you despite enabling the do-not-disturb function, the external telephone numbers (VIP numbers) of these people can be assigned a call deblocker for incoming calls in the PBX. The call deblocker which applies to all subscribers can be enabled on your own telephone as needed. If the call deblocker is enabled, the do-not-disturb function does not apply to callers who use one of the VIP numbers.

### **Call Forwarding**

Call forwarding allows calls to be forwarded. When this is done, a difference is made between calls to a specific telephone (call forwarding for subscribers), to groups (call forwarding for groups) and to connections (call forwarding for external telephone numbers).

### **Call Recording**

The call recording function enables telephone calls to be recorded, for example, for later evaluation. In addition to the automatic recording of all calls, it is also possible to record calls manually. This functions independent of the automatic call recording function. This allows calls to be recorded in pieces.

### **Call Restrictor (Incoming) – Robinson Numbers**

If there are certain persons who you absolutely do not want to call you, their external phone numbers (Robinson numbers) can be assigned to a call restrictor for incoming calls in the PBX. The call restrictor which applies to all subscribers can be enabled on your own telephone as needed. If the call restrictor is enabled, a caller, who transmitted one of the Robinson numbers, is rejected.

### **Call Waiting**

If you are already in a call, the call waiting function notifies you using the call waiting tone when another communication partner is calling.

### **Callback on Busy**

After initiating a callback on busy (CCBS), a subscriber is automatically called back by the PBX or by the central office when a busy subscriber becomes available again.

### **Callback on No Reply**

After initiating a callback on no reply (CCNR), a subscriber is automatically called back by the PBX or by the central office when a subscriber is reachable again.

### **Caller List**

Telephone numbers of calls not accepted are saved in the caller list of the telephone, along with the number of call attempts as well as the date and time of the call (for multiple call attempts, date/time of the last call attempt). A maximum of 30 telephone numbers can be saved. If more than 30 calls from various telephone numbers come in, the oldest entry is overwritten.

A caller be called back directly from the caller list.

The LED above the message key indicates whether entries are present on the caller list.

### **Calls**

The system telephone allows you to make internal and external calls on the PBX. Internal calls are toll-free.

### **Calls List**

The calls made (incoming and outgoing) are saved in the calls list of the telephone along with the telephone number of the communication partner as well as date, time and duration of the call. A maximum of 30 calls can be saved. For more than 30 calls, the oldest entry is overwritten. A previous communication partner can called directly from the calls list.

### **Conference Calls**

During a conference call, you are talking with two subscribers simultaneously.



### **Configuration Switchover**

If multiple configurations have been saved in the PBX, for example, for day, night, etc., switching over from one configuration to another can be carried out manually and/or in a time controlled manner.

---

## **D**

### **Data Backup**

During a data backup, a backup file is created either automatically or manually. This file contains the configuration and/or other data and settings for the telephone. The areas to be backed up can be configured separately.

### **DDI**

The DDI (Direct Dialing In) is the extension number for dialing directly to a specific subscriber on a telephone system. Example: In the number 0 53 06 / 92 00 - 700, 700 is the extension (DDI) for the Auerswald info-line.

### **Direct Exchange Line Access**

If the telephone has been configured as a direct exchange access point on the PBX, you will hear an external dial tone directly after picking up the receiver. You can directly dial the telephone number without the leading 0.

### **Do-not-disturb**

The do-not-disturb function offers the option of blocking internal and external calls as well as blocking group calls on a specific telephone. A caller hears only a busy signal. An internal subscriber can reach a telephone with call protection in an emergency using a priority call.

The do-not-disturb function has no influence on outbound calls, callbacks, alarm calls, scheduled calls, wake-up calls or InterCom calls.

### **Door Functions**

A door terminal system connected with the interface FTZ 123 D12-0 (PBX requires extension module) enables the following functions. Calls to the door can be made from any telephone (intercom). During a call to the door, the door can be opened (open door) and a stairwell light controlled by switching a relay (switch on light).

These functions can be executed on the system telephone without initiating a door call.

---

## **E**

### **Exchange Line Transfer**

A suitably authorised telephone, for example, the telephone exchange, can transfer the exchange line access required for an outgoing call to another internal telephone for a short period of time. This is meaningful, for example, when this telephone is located in a publicly accessible room and is only occasionally used for external calls by an employee.

---

## **F**

### **Firmware**

Firmware is the operating software on the telephone or PBX that is stored in the device itself. The device cannot function without firmware.

### **Firmware Update**

When firmware is updated, errors are corrected and new features are installed. To do this, the device establishes a connection to a server in order to download the most current firmware (the device settings remain intact). Except for the charges for the required server connection, the update is free of charge.

### **Follow me**

Follow me is a type of "internal call forwarding unconditional for subscribers" that is configured on the respective destination telephone (instead of on the forwarding telephone). This provides the option of going from room to room and taking the calls with you.

---

## **G**

### **Group Functions**

In addition to internal subscribers, the PBX can also manage groups. The internal subscribers can become members of any and all groups. These groups can be used, for example, to collect the internal subscribers in certain departments or teams (Support, Marketing, Sales) together.

Membership in a group does not necessarily mean that a subscriber receives calls sent to the group. A subscriber that is logged out takes on no group functions. This can be especially important for employees of a support department, who should not be available to customers around the clock, but rather rotate in and out of the hotline.

---

## **H**

### **Hands-free Calling**

During hands-free calling, the loudspeaker and microphone on the device are switched on. This option allows you to talk on the telephone even if you have no hands free. In addition, other people in the room can participate in the call.

### **Headset Calls**

A headset enables you to participate in calls when you have no hands free. This is a very useful feature, especially in certain professional areas (for example, in a call center).

### **Hotel Function**

The hotel function allow you to conveniently manage room and call data when the PBX is used in a hotel.

---

I

### **InterCom Announcement/Handsfree**

The InterCom function enables an announcement to one system telephone or to all system telephones of a group from any internal telephone without someone having to actively receive a call (for example, in a doctor's office).

If the InterCom destination is one system telephone, this can be programmed to switch on the microphone in addition to the loudspeaker (handsfree) so that a person nearby can speak with the caller using this intercom system.

---

L

### **LED**

An LED is a light emitting diode. This is an electronic device that is similar to a lamp and is used for displays (also multi-coloured).

### **Loudspeaker Listening**

During loudspeaker listening, the receiver loudspeaker as well as the loudspeaker in the device are switched on. This allows other people in the room to listen in on the call. The call is continued using the receiver microphone (no hands-free calling).

### **Loudspeaker Audio Out**

This function enables loudspeaker audio out over an audio output on the loudspeaker connected to the PBX unit or an active loudspeaker (for example, a loudspeaker system in a department store/supermarket). In addition, a previously specified telephone number is called by an internal telephone. The call connection is immediately established after dialling the telephone number.

---

## **M**

### **Macro**

The macro function enables a function key to be defined with digits and various consecutive commands, for example, for accessing an answering machine remotely or programming a function on the PBX.

### **Memo**

The memo function allows you to enter a telephone number note on the telephone during a call. After the call has been ended, the telephone number can be retrieved and, for instance, accepted into dial preparation.

### **Message Forwarding**

Message forwarding enables the answering machine to notify you of new messages even if you are out and about.

### **MSN**

An ISDN point-to-multipoint connection is reachable under multiple telephone numbers, the MSN (Multiple Subscriber Number) or multiple subscriber numbers. The MSN is the part of the telephone number without a local prefix.

## **Mute**

If you would like to discuss something with another person in the room without your communication partner on the telephone being able to hear, you can temporarily mute the call.

---

## **P**

### **Permanent Configuration**

For situations where your settings are supposed to apply even after configuration switchovers, you can use the so-called permanent configuration. If permanent configuration is enabled, the configuration-dependent settings will be overridden by the permanent configuration settings.

Permanent configuration is available for the following settings:

- Call forwarding for external number

### **Phone Lock**

The phone lock can be used to block the telephone from unauthorised use. Even after enabling the phone lock, it is possible to receive incoming calls and to make emergency calls (manual dialling of emergency numbers entered in the PBX only).

### **Pickup**

Using Pickup, you can take a call on your own phone that was originally sent to another internal telephone.

If the call has already been taken, the call can be taken using same procedure if the call take-over has been allowed by the subscriber being called. This function is useful, for example, in the case of answering machines.

### **PIN**

A PIN (Personal Identification Number) is a multi-digit secret code that has to be entered to get access to services or authorisations.

### **Power Dialling**

If the telephone being called is busy, but automatic callback on busy is not possible, the power dialling function be activated instead. When this is done, the system telephone attempts to reach the subscriber being called in short time intervals.

### **Power Save Mode**

In power save mode, the display lighting (if available) and the LEDs are inactive (exception: the message LED blinks for missed calls).

After a configurable waiting time and depending on the configuration, power save mode can be activated automatically during the switchover into a PBX configuration and/or manually by pressing a key. Power save mode is deactivated again as soon as an incoming call is signalled or any key is pressed.

### **Priority Call**

When the do-not-disturb function is enabled, a subscriber is no longer reachable by normal callers. A priority call creates an exception and allows the incoming internal call to circumvent the do-not-disturb function.

### **Project Assignment**

The exchange line access with project assignment enables an external call to be assigned to a specific project/customer/client (for example, in a lawyer's office). Based on the evaluation of call data, both the charges as well as the time required can be assigned to a specific project.

---

## Q

### **Query Calls**

During a query call, you are talking with one subscriber while your previous communication partner is on hold on the PBX in the background listening to hold music.

A query call is initiated either by calling a query call subscriber, using pick-up during a call, or by accepting a call signalled by call waiting.

## R

### **Readiness**

In order for the answering machine to accept calls and record messages, readiness must be enabled.

### **Redial List**

The last 30 telephone numbers dialled are saved in the redial list. For more than 30 telephone numbers dialled, the oldest entry is overwritten. The telephone numbers are saved along with number of dialling operations, date and time of dialling (for multiple dialling operations, the date/time of the last attempt).

### **Relays**

If the PBX is equipped with one or more relays, they can be switched on and off independently of the operating mode configured for each telephone.

### **Remote Access**

Remote access is used to access and operate the answering machine from another internal telephone or from an external telephone.

### **Room Monitoring**

The room monitoring function can be used for monitoring a room acoustically, for instance, for monitoring a small child while she sleeps. The internal telephone in this room must be suitably configured for this purpose.

The configured telephone can then be called by another internal telephone or by a password-protected external telephone. The connection is established immediately and it is possible to listen into the room.



## S

### **Scheduled Call**

The scheduled call provides the option of being reminded of a schedule or to place a specific call by the system telephone. The telephone can be configured with up to 16 schedules. The configured schedules are saved in a scheduled call list in the order they are to be processed.

### **Server**

A server is a computer or a software. Depending on the type of server it fulfils different tasks as part of the network. It provides, for example, other users (clients) in this network with certain information, data and services.

### **Splitting**

Splitting is the switching between two calls. As opposed to a conference call, you can only speak to each communication partner by going back and forth between the two. When you speak with one communication partner, the other call is kept on "hold".

---

## T

### **Targeted Exchange Line Access**

Using targeted exchange line access, you can define which MSN (your own external phone number) is transmitted for an external call and which exchange line should be used while doing so.

### **Targeted VoIP Access Point**

Using a targeted VoIP access point, an external call can be initiated via a specific VoIP account.

### **Telephone Book**

The telephone book is used for storing useful or frequently dialled telephone numbers along with the associated names. If a telephone number that is entered in the telephone book is transmitted during a call, the assigned name is displayed instead of the telephone number is displayed.

In the telephone book, entries (telephone numbers, macros and comments) can be stored. Up to four entries can be assigned to a name (contact).

In addition, internal telephone numbers (subscriber, groups, door, emergency call) as well as the telephone book/short-code numbers on the PBX are displayed. If one of these entries does not have a name, the system telephone generates a name for the telephone book (for example, int. TN45, KW-A 05306...). The entries cannot be changed in the telephone book of the system telephone; they can only be changed using the corresponding PC software on the PBX (internal telephone numbers with COMset; short-code numbers with COMtools). Each name (contact) is assigned only one telephone number entry. All of the contacts are displayed in alphabetical order.

### **Text before Answering**

The text before answering function enables the caller to be greeted with an automatic announcement before accepting the call (charges apply for the external caller).

### **Transfer**

A communication partner can be transferred or connected to an internal or external subscriber.

### **Transferring Without Announcement**

This describes a type of transfer where external calls are transferred to internal subscribers. The caller is put through to the desired subscriber without an announcement.

## V

### **Voicemail Center 461/461.2**

If a Voicemail Center 461/461.2 (optional accessory from Auerswald) is connected to an Auerswald PBX, its mailboxes can be accessed/managed over the system telephone.

### **VoIP Account**

To get the access data needed for VoIP calls, accounts have to be set up from one or several VoIP providers. To do this, a registration with name and address data has to be done on the website of a provider. Afterwards, one or several telephone numbers which are available on the fixed network and the Internet as well as an account with user name and password are assigned. In the majority of cases the registered account is available within a few minutes and can be used very soon.

---

## W

### **Waiting Field Function**

In a waiting field, callers can be parked either automatically or by pressing the key, and then individually retrieved and forwarded.

### **Waiting Loop**

If the internal subscriber to which you would like to transfer an external communication partner is busy, you can place the external communication partner in the waiting loop of this subscriber.

## Abbreviations

CCBS	Completion of Calls to Busy Subscriber
CCNR	Completion of Calls on No Reply
CF	Call Forwarding
CFB	Call Forwarding on Busy
CFNR	Call Forwarding on No Reply
CFU	Call Forwarding Unconditional
CLIP	Calling Line Identification Presentation
CLIR	Calling Line Identification Restriction
CW	Call Waiting
DDI	Direct Dialling In
DTMF	Dual Tone Multi Frequency
ISDN	Integrated Services Digital Network
LED	Light Emitting Diode
MSN	Multiple Subscriber Number
PBX	Private Branch Exchange
PIN	Personal Identification Number
USB	Universal Serial Bus



# Index

## A

- abbreviations .....580
- active communication partner,  
changing (splitting) .....87
- announcement
  - change manually with key .....388
  - create .....524
  - edit .....525
  - specific for telephone book
  - contacts .....118
  - switch call information on/off .....527
  - switch separator tone on/off .....527
  - time control .....411
- announcement (InterCom) .....251, 572
  - function key .....252
- announcements .....524
  - recording (answering machine) ...385
- answering machine
  - announcements, recording .....385
  - answering machine list .....374, 566
  - automatic for experts, configure ..395
  - basic settings .....415
  - call acceptance readiness ...370, 576
  - call acceptance time .....415
  - call acceptance/announcement  
assignment .....391
  - call recording .....422, 567
  - call recording, automatic .....425
  - call recording, info tone .....428
  - call recordings, listening to  
(answering machine list) .....376
  - call types .....392
  - data exchange .....448
  - forward call .....368
  - icons .....46
  - listen in function .....419
  - memos, listen to .....384
  - memos, record .....380
  - message forwarding .....438, 573
  - message forwarding  
announcement .....442
  - message forwarding, repetition ..446
  - message forwarding, target .....443
  - message forwarding,  
waiting period .....445
  - messages, listening to  
(answering machine list) .....376
  - playback, automatic .....420
  - quick remote access number .....434
  - readiness .....370, 576
  - recording time .....416
  - recording time,  
door terminal calls .....418
  - remote access .....430, 576
  - remote access toll saver .....433
  - remote access, configure .....431
  - remote access, execute .....436
  - time control .....411
- answering machine list .....374, 566
  - display navigation .....374, 500
  - function key .....377
  - open .....374, 382
  - recordings, listening to .....376
  - telephone number, dial .....377
- answering machine menu .....41
- attention tone
  - automatic call acceptance .....149
  - power dialling .....284
  - waiting field .....366
- automatic (answering machine)
  - anonymous calls .....397
  - anonymous calls  
(create entry) .....407, 411
  - call deblocker calls .....405
  - calls for groups .....398
  - door terminal calls .....404
  - external calls .....400
  - function key .....408

- internal calls .....402
  - time control .....411
  - automatic call acceptance .....146, 566
  - attention tone .....149
  - call acceptance time .....150
  - function key .....147
  - switch on/off .....146
- B**
- backlight .....463
  - backup .....552, 569
    - on PC .....552
    - on SD card .....555
  - BERT .....563
  - boss key .....156
  - boss/secretary function .....152, 566
    - switching off (function key) .....160
  - brightness .....465
  - busy signal
    - callback, initiate .....79
    - end call for query call .....81
    - priority call (do-not-disturb) .....81
- C**
- call .....83, 568
    - accept .....68
    - call waiting, accept .....72
    - call waiting, forward .....73
    - call waiting, ignore .....74
    - call waiting, reject .....72
    - display navigation .....34
    - DTMF signals, send .....84
    - end .....85
    - forward .....70
    - hands-free calling .....96, 571
    - hands-free calling, switch off .....97
    - hands-free calling, switch on .....97
    - headset .....100, 571
    - icons .....43
    - incoming call, on hold .....69
    - interrupt for pickup .....279
    - loudspeaker listening .....98, 572
    - loudspeaker listening, switch off .. 98
    - loudspeaker listening, switch on .. 98
    - mute .....84
    - project assignment .....293
    - reject .....69
    - subscriber, changing .....87
    - third communication partner,
      - transfer .....92
    - to boss telephone .....152
    - transfer .....89, 578
    - transfer from query call .....92
    - transfer without announcement .... 90
  - call acceptance
    - specific for telephone book
      - contacts .....118
  - call acceptance readiness .....370, 576
  - call acceptance time .....415
  - call charges .....484
  - call charges, configure
    - cost per call unit .....484
    - currency .....484
  - call deblocker
    - function key .....163
    - switch on/off .....162, 189
  - call deblocker (incoming) .....162, 567
  - call deflection (forward call) .....70
  - call forwarding .....166, 567
    - for external numbers .....177
    - kinds .....167
    - subscribers .....168
    - variants .....323
    - variations .....166
  - call forwarding (ext. no.)
    - function key .....179
    - switch on/off .....177
  - call forwarding (subscribers)
    - function key .....169
    - switch on/off .....168
  - call macro, configure .....116

- call recording .....422, 567
  - automatic .....425
  - automatic, function key .....426
  - function key .....423
  - info tone .....428
  - listening to
    - (answering machine list) .....376
- call restrictor
  - function key .....190
- call restrictor (incoming) .....189, 567
- call signal, light
  - function key .....474
- call signalling, configure .....470
- call waiting .....193, 567
  - call waiting calls .....71
  - call waiting tone, switch off .....74
  - call waiting, accept .....72
  - call waiting, forward .....73
  - call waiting, reject .....72
  - call, ignore .....74
  - door knocks .....210
  - function key .....194
  - signalling .....196
  - switch on/off .....193
- call, end
  - during conference call .....95
  - during query call .....88
- call, incoming .....67
- call, initiate .....75
  - from answering machine list .....377
  - from caller list .....138
  - from calls list .....132
  - from redial list .....128
  - from telephone book .....105
  - from the calls list .....132
  - in hands-free calling mode .....96
  - on direct exchange line
    - access .....76, 77
  - via targeted exchange line
    - access .....324
  - via targeted VoIP access point ....333
    - with dial preparation .....76
    - with number presentation
      - suppression .....77
- callback
  - initiate on busy .....79
  - initiate on no response .....80
  - on busy .....568
  - on no reply .....568
- caller list .....137, 568
  - call types, select .....142
  - display navigation .....137
  - entries, delete .....139
  - function key .....140
  - open .....137
  - signalling LED, select .....143
  - telephone number, dialling .....138
- calls list .....131, 568
  - call types, select .....135
  - display navigation .....131
  - entries, delete .....133
  - function key .....133
  - open .....131
  - telephone number, dialling .....132
- calls, outgoing .....75
- CCBS (callback on busy) .....79
- CCNR (callback on no response) .....80
- CE symbol ..... see insert "Conditions of Guarantee, Information Service"
- CE symbol ..... see insert "Warranty Conditions, Information Service"



- COMfortel Set
    - entry fields .....59
    - exit .....51
    - installation .....50
    - interface, configure .....52
    - language, configure .....52
    - list entries, create .....60
    - list entries, delete .....60
    - navigation .....59
    - operating instructions .....59
    - print functions .....57
    - selection fields .....59
    - start .....51
    - V.24 options, configure .....53
  - comments .....115
  - conditions of guarantee .....see insert  
"Conditions of Guarantee, Information  
Service"
  - conference
    - both conference call partners,  
connect .....95
    - options .....93
  - conference call .....93, 568
    - conference call partner, end call ...94
    - end completely .....95
    - initiate .....93
  - conference call, initiate .....93
  - configuration
    - close .....57
    - create .....55
    - open .....54
    - permanent configuration .....574
    - save on PC .....56
    - save on telephone .....56
  - configuration file, open .....54
  - configuration software .....50
    - entry fields .....59
    - exit .....51
    - installation .....50
    - interface, configure .....52
    - language, configure .....52
    - list entries, create .....60
    - list entries, delete .....60
    - minimum requirements, PC .....50
    - navigation .....59
    - output fields .....59
    - print functions .....57
    - start .....51
    - V.24 options, configure .....53
  - configuration switchover .....198, 569
    - function key .....199
    - manual .....198
  - configuration-dependent control
    - function key .....513
    - voice mailbox .....512
  - contrast .....466
  - cost per call unit .....484
  - currency .....484
- D**
- data backup .....552, 569
    - on PC .....552
    - on SD card .....555
  - data exchange .....448
  - data, delete .....560
  - date format .....468
  - DDI .....569
  - declaration of conformity ..... see insert  
"Conditions of Guarantee, Information  
Service"
  - declaration of conformity ..... see insert  
"Warranty Conditions, Information  
Service"
  - delete
    - charges .....561
    - personal data .....561
  - deleting charges .....561
  - diagnosis menu .....41
  - diagnostic functions .....563

- dial
    - from answering machine list .....377
    - from caller list .....138
    - from calls list .....132
    - from redial .....128
    - on direct exchange line access .....77
  - dial preparation .....76
    - icons .....42
    - number into telephone book .....119
  - dialling
    - DTMF codes in call .....84
    - from telephone book .....105
    - out of a call (query call) .....86
    - telephone number .....76
  - display
    - answering machine list .....374, 500
    - call, during .....34
    - caller list .....137
    - calls list .....131
    - idle state .....28
    - incoming call .....32
    - inverse display view .....466
    - key definition .....30
    - main menu .....29
    - outgoing call .....33
    - query call, during .....35
    - redial .....127
    - telephone book .....104
    - telephone number entry .....31
    - text entry .....31
  - display backlight .....463
    - brightness, configure .....465
    - use as ring signal .....473
  - display settings
    - contrast .....466
    - date format .....468
    - language .....463
    - time format .....467
  - display view, inverse .....466
  - do-not-disturb .....203, 569
    - function key .....204
    - ignore (priority call) .....81
    - switch on/off .....203
    - type .....206
  - door
    - accept door call .....210
    - door knocks .....210
    - open door .....210
  - door functions .....209, 570
    - function key .....211
- E**
- entry fields
    - COMfortel Set .....59
  - environment ... see insert "Conditions of Guarantee, Information Service"
  - environment .....see insert "Warranty Conditions, Information Service"
  - exchange line access, targeted
    - initiating .....324
  - exchange line transfer .....216, 570
    - function key .....217
    - sequence .....216
  - export (telephone book) .....125
  - external waiting field
    - function key .....357
- F**
- factory settings .....560
  - factory settings, reset .....560
  - firmware .....570
    - distribute .....550
    - save on PC .....551
  - firmware update .....547, 570
    - manual .....547
    - update server .....549
    - update, carry out instant .....549
    - variants .....547

- firmware update, instant .....549
  - follow me .....219, 571
    - function key .....220
  - follow-me
    - switch on/off .....219
  - function key
    - announcement, editing .....388
    - answering machine list .....377
    - automatic (answering machine) ..408
    - automatic call acceptance .....147
    - boss key .....156
    - boss/secretary function,
      - switching off .....160
    - call deblocker .....163
    - call forwarding (ext. no.) .....179
    - call forwarding (subscribers) .....169
    - call recording .....423
    - call recording, automatic .....426
    - call restrictor .....190
    - call signal, light .....474
    - call waiting .....194
    - caller list .....140
    - calls list .....133
    - configuration switchover .....199
    - configuration-dependent control .513
    - do-not-disturb .....204
    - door functions .....211
    - exchange line transfer .....217
    - follow me .....220
    - group functions .....225
    - group status .....232
    - headset .....487
    - hotel reception telephone .....246
    - hotel room telephone .....248
    - InterCom announcement .....252
    - InterCom handsfree .....257
    - InterCom permission .....260
    - log out of all groups .....230
    - loudspeaker audio out .....264
    - macro .....268
    - message forwarding .....440, 536
    - move messages .....520
    - MSN/DDI call forwarding .....179
    - open voice mailbox .....502
    - phone lock .....276
    - pickup .....280
    - power save mode .....289
    - project assignment .....294
    - readiness .....371
    - readiness voice mailbox .....508
    - relays .....302
    - remote access .....531
    - ring signal .....471
    - room monitoring .....306
    - scheduled call .....313
    - secretary key .....153
    - shift .....494
    - speed dialling .....317
    - subscriber call forwarding .....169
    - substitute function .....541
    - targeted exchange line
      - access .....324, 327, 329
      - targeted VoIP access point .....334
      - text before answering .....338, 341
      - time control .....412
      - voice memos .....381, 517
    - voicemail center .....345
    - waiting field (external) .....357
    - waiting field (internal) .....360
    - waiting field reception .....363
  - function keys
    - exchange/move .....496
    - second level, enable .....492
  - function lock, configure .....458
  - function menu .....37
  - functions keys
    - print assignment .....57
- G**
- glossary .....565
  - group functions .....223, 571
    - detailed information .....223
    - function key .....225
    - log out of all groups .....225
    - log telephone in/out .....224

group status  
function key .....232

**H**

handsfree (InterCom) .....251, 572  
function key .....257

hands-free calling .....96, 571

## headset

call, make .....100, 571  
function key .....487  
operation, switch on/off .....486  
ringing .....490  
technical data .....22  
type .....489  
volume .....491

help .....61

icons .....65  
navigation .....61  
opening .....61  
printing .....65  
search .....64

hotel function .....235, 572  
configure .....236  
function areas .....235

## hotel reception telephone

block external telephoning .....242  
check/change room status .....238  
function key .....246  
perform check-in .....239  
perform check-out .....242  
print interim invoice .....241  
query call charges .....240

## hotel room telephone

configure wake-up time .....245  
function key .....248  
query call charges .....245

**I**

icons .....42  
answering machine .....46  
calls .....43  
confirmation .....45  
dial preparation .....42  
idle state .....42  
key definition .....44  
menu navigation .....43  
restriction .....46  
scheduled call .....46  
selection .....44  
telephone book .....45  
telephone number entry .....44  
telephone number lists .....45  
text entry .....44  
voice mailbox .....47  
voicemail center .....47

identification of telephone .....455

## idle state

icons .....42  
menu options .....28

## import

Outlook contacts .....123  
telephone book .....122

important information .....17

## incoming call

display navigation .....32

incoming call, on hold .....69

information menu .....36

## initiate call

from the message list of the  
voice mailbox .....502

## installation

COMfortel Set .....50

InterCom announcement .....251, 572

execute .....252  
function key .....252  
procedure .....251

- InterCom handsfree .....251, 572
    - execute .....256
    - function key .....257
    - procedure .....256
  - InterCom permission .....259
    - function key .....260
  - interface
    - COMfortel Set .....52
  - internal waiting field
    - function key .....360
- K**
- key definition
    - icons .....44
  - key definition menu .....37
  - keys .....26
- L**
- language, configure .....463
  - LED .....572
  - LED message key .....143
  - LEDs .....26
  - line check (BERT) .....563
  - list entries
    - create (COMfortel Set) .....60
    - delete (COMfortel Set) .....60
  - listen in function .....419
  - listening to recordings
    - voice mailbox .....501
  - log into a group .....224
  - log out of a group .....224
  - log out of all groups
    - function key .....230
  - loudspeaker audio out .....263, 573
    - execute .....263
    - function key .....264
  - loudspeaker listening .....98, 572
- M**
- macro ..... 267, 573
    - display presentation ..... 271
    - execution procedure ..... 267
    - function key ..... 268
  - main menu
    - menu options ..... 29
  - maintenance ..... 546
  - manager telephone
    - secretary key ..... 153
  - manual firmware update ..... 547
  - memo ..... 273, 573
    - create ..... 273
    - retrieve ..... 274
  - memos (list)
    - recordings, listen to ..... 384
  - menu navigation
    - icons ..... 43
  - menu options ..... 28
    - call, during ..... 34
    - icons ..... 42
    - in idle state ..... 28
    - incoming call ..... 32
    - key definition ..... 30
    - main menu ..... 29
    - outgoing call ..... 33
    - query call, during ..... 35
    - telephone number entry ..... 31
    - text entry ..... 31
  - menu overview ..... 36
    - answering machine menu ..... 41
    - diagnosis menu ..... 41
    - function menu ..... 37
    - information menu ..... 36
    - key definition menu ..... 37
    - settings menu ..... 39
  - menu selection, restrict ..... 492

- message forwarding .....438, 535, 573
    - announcement .....442
    - function key .....440, 536
    - repetition .....446
    - switching on/off .....535
    - target .....443
    - waiting period .....445
  - messages, listening to  
(answering machine list) .....376
  - microphone
    - switch off .....84
  - minimum requirements, PC .....50
  - MSN .....573
    - configure .....455
  - MSN/DDI call forwarding
    - function key .....179
    - switch on/off .....177
  - mute .....84, 574
- N**
- navigation
    - COMfortel Set .....59
  - no response
    - callback, initiate .....80
- O**
- operating instructions
    - COMfortel Set .....59
  - outgoing call
    - display navigation .....33
  - Outlook contacts, import  
(telephone book) .....123
  - output fields
    - COMfortel Set .....59
- P**
- PBX
    - select .....558
    - services test .....564
    - synchronisation .....559
  - PC
    - data backup .....552
    - minimum requirements .....50
  - permanent configuration .....574
  - personal data
    - delete .....561
  - phone lock .....275, 574
    - disable .....275
    - enable .....275
    - function key .....276
  - pickup .....279, 574
    - during call .....279
    - execute .....279
    - function key .....280
  - PIN .....574
    - configure .....457
  - playback, automatic .....420
  - power dialling .....283, 575
    - attention tone .....284
    - cancel .....284
    - execute .....283
    - procedure .....283
  - power save mode .....286, 575
    - activation depending
      - on configuration .....287
      - automatic activation .....286
      - function key .....289
      - link to phone lock .....290
  - print functions .....57
  - priority call .....575
    - initiate .....81

- project assignment .....292, 575
    - during call .....293
    - function key .....294
    - initiate .....292
    - list, configure .....298
    - list, export .....298
    - list, import .....299
    - list, print .....57
  - proper use .....19
- Q**
- query call .....86, 575
    - both communication partners,
      - connect .....88
      - call, ending .....88
      - initiate .....86
      - number calls is busy/no response 81
  - query call, end .....81
  - quick remote access number .....434
- R**
- readiness .....370, 576
    - function key .....371
  - readiness voice mailbox .....507
    - function key .....508
    - switch on/off .....507
  - receiver volume .....486
  - reception telephone
    - configure wake-up time .....239
  - recording time .....416
    - door terminal calls .....418
  - redial list .....127, 576
    - call types, select .....129
    - display navigation .....127
    - entries, delete .....129
    - open .....127
    - select .....128
  - registration status .....321
  - reject
    - call waiting ..... 72
    - caller ..... 69
  - relays ..... 301, 576
    - function key ..... 302
    - switch on/off ..... 301
  - remote access ..... 430, 576
    - configure ..... 431
    - execute ..... 436
    - variants ..... 430
    - voice mailbox ..... 529
  - remote access toll saver ..... 433
  - reset factory settings ..... 560
  - restriction
    - icons ..... 46
  - restrictions ..... 457
    - function lock ..... 458
    - settings lock ..... 460
  - ring signal
    - function key ..... 471
  - ringer
    - by flashing display backlight ..... 473
    - melodies, configure ..... 480
    - switch on/off ..... 470
    - volume, configure ..... 480
    - volume, increase automatically .. 482
  - Robinson numbers ..... 189, 567
  - room monitoring ..... 305, 576
    - end ..... 305
    - function key ..... 306
    - initiate ..... 305
- S**
- safety information ..... 18
  - scheduled call ..... 308, 577
    - accept as call reminder ..... 312
    - accept as schedule reminder .... 311
    - configure as call reminder ..... 310
    - configure as schedule reminder . 309

- function key .....313
  - icons .....46
  - open list .....308
  - scheduled call list
    - delete scheduled calls .....313
    - edit scheduled calls .....312
  - SD card
    - data backup .....555
    - testing .....564
  - SD card, testing .....564
  - secretary function .....152, 566
  - secretary key .....153
  - secretary telephone
    - boss key .....156
  - selection
    - from the message list of the voice mailbox .....502
    - icons .....44
  - server .....577
  - service .....546
  - service ..... see insert "Conditions of Guarantee, Information Service"
  - service ..... see insert "Warranty Conditions, Information Service"
  - services test .....564
  - settings lock, configure .....460
  - settings menu .....39
  - shift .....494
  - speed dialling .....316
    - automatic pick-up .....320
    - function key .....317
    - registration status .....321
  - speed dialling keys
    - application options .....316
  - splitting .....87, 577
    - active call, ending .....88
    - active communication partner, transfer ..... 92
    - both communication partners, connect ..... 88
    - from query call ..... 87
    - initiating from conference call ..... 94
    - to third subscriber, transfer ..... 92
  - subscriber call forwarding
    - function key ..... 169
    - switch on/off ..... 168
  - subscribers, changing (splitting) ..... 87
  - substitute function
    - switching on/off ..... 540
  - suppress
    - telephone number display ..... 77
  - switching remote access on/off ..... 530
  - synchronisation (PBX) ..... 559
- T**
- targeted exchange line access . 323, 577
    - function key ..... 324, 327, 329
  - targeted VoIP access point ..... 333, 577
    - function key ..... 334
    - initiate ..... 333
  - technical data ..... 21
  - telephone
    - identification ..... 455
  - telephone book ..... 102, 103, 578
    - call macro, configure ..... 116
    - comments ..... 115
    - contact, delete ..... 114
    - contact, edit ..... 109
    - export ..... 125
    - icons ..... 45
    - import ..... 122
    - new contact, configure ..... 106
    - open ..... 103
    - Outlook contacts, import ..... 123
    - print ..... 57



specific call acceptance/  
 announcement .....118  
 telephone number from dial  
 preparation .....119  
 telephone number range,  
 configure displayed .....121  
 telephone number, dial .....105  
 telephone number display  
 suppress .....77  
 telephone number entry  
 icons .....44  
 telephone number lists .....102  
 icons .....45  
 telephone ringer, switch on/off .....470  
 telephoning  
 call waiting calls .....71  
 call, accept .....68  
 call, incoming .....67  
 caller, reject .....69  
 calls, outgoing .....75  
 conference call, initiate .....93  
 during conference call .....93  
 during query call .....87  
 text before answering  
 function key .....338, 341  
 variants .....337  
 text before answering for group .337, 578  
 switch on/off .....338, 341  
 text entry  
 icons .....44  
 time control  
 function key .....412  
 time format .....467  
 transfer .....89, 578  
 from query call .....92  
 in waiting loop, place .....91  
 options .....89  
 to third communication partner .....92  
 with announcement .....90  
 without announcement .....90

transfer without announcement ..... 90  
 transferring without announcement . 578  
 transmission  
 telephone number, suppress ..... 77  
 type of do-not-disturb ..... 206

## U

update server ..... 549  
 user PIN, configure ..... 457

## V

V.24 options  
 COMfortel Set ..... 53  
 VIP numbers ..... 162, 567  
 voice mailbox ..... 498  
 announcements ..... 524  
 configuration-dependent control 512  
 create announcement ..... 524  
 edit announcement ..... 525  
 execute remote access ..... 529  
 function key open ..... 502  
 function key remote access ..... 531  
 icons ..... 47  
 Listening to recordings ..... 501  
 message forwarding ..... 535  
 move messages ..... 520  
 open ..... 499  
 readiness ..... 507  
 remote access ..... 529  
 substitute function ..... 540  
 switch readiness on/off ..... 507  
 switch remote access on/off ..... 530  
 switch substitute function on/off . 540  
 switching message forwarding  
 on/off ..... 535  
 voice memos ..... 517  
 voice memo, record ..... 380  
 voice memos ..... 517  
 function key ..... 381, 517

voice memos (list) .....	380
open .....	382
Voicemail Center .....	345, 579
function key .....	345
initiate remote access .....	345
rapid remote access .....	351
Voicemail Center	
icons .....	47
VoIP account .....	579
volume	
headset .....	491
receiver .....	486
volume, change	
automatically .....	482

## W

waiting field	
attention tone .....	366
configure .....	353
waiting field (external)	
function key .....	357
waiting field (internal)	
function key .....	360
waiting field function .....	353, 579
sequence for call acceptance .....	355
waiting field reception	
function key .....	363
switch on/off .....	356
waiting loop .....	91, 579
warranty .....	see insert "Conditions of Guarantee, Information Service"
warranty .....	see insert "Warranty Conditions, Information Service"

