



CC-48



BCB-60

CAN COOLERS

BCB-60 / CC-48

Key Features

- Small Footprint and Easy Mobility to Best Generate Impulse Sales
- Heavy Duty Casters
- Adjustable Thermostat
- Transparent Self-Closing Lid
- 7 Foot Power Cord
- High Impact Graphics Available

Model	Doors	Capacity cu.ft (lt)	Shelves	Exterior Dimensions inches (mm)		Interior Dimensions inches (mm)		Power (V-Hz-Ph)	Amps	HP	Crated Weight lbs (kg)
				DIA	H	DIA	H				
BCB-60	N/A	1 3/4 (48)	N/A	17 3/4 (450)	37 (940)	14 7/8 (378)	20 (508)	115.60.1	1 1/2	1/10	80 (36)
CC-48	N/A	1 3/4 (48)	N/A	21 1/4 (540)	33 3/4 (860)	16 (406)	16 (406)	115.60.1	3	1/5	80 (36)

Details

Cabinet Construction

- Exterior: Galvanized, pre-painted steel cabinet, white.
- Interior: Durable ABS Plastic lining allows for easy cleaning.
- High-density, CFC-Free, polyurethane insulation.
- Custom channels allow for effortless change of graphics on BCB-60.
- Four (4) heavy-duty 2 inch casters for easy mobility.

Lid

- Self-closing clear plastic lid for maximum product visibility and increased energy efficiency.
- Lid opens on both sides.

Shelving

- Wire divider on BCB-60 allows for separation of 2 different products and increases interior air flow.

Electrical

- Ready for connection to 115V/60Hz single phase 20 amp outlet.
- Includes a 7' cord and plug set.



NEMA 5-15R

Refrigeration System

- Forced air refrigeration system on BCB-60 ensures quick cooling of products.
- Cold wall refrigeration system on CC-48 will keep product cold for up to 12 hours without electrical supply.
- Utilizes environmentally friendly CFC-Free R134A refrigerant.

- Electronic temperature control maintains 34°F to 41°F (1°C to 5°C).
- Bottom mounted refrigeration unit allows for easy maintenance and service.

Options

- 208-230V/ 50Hz
- Custom Graphics
- Various Cabinet Colors

Technical Drawing

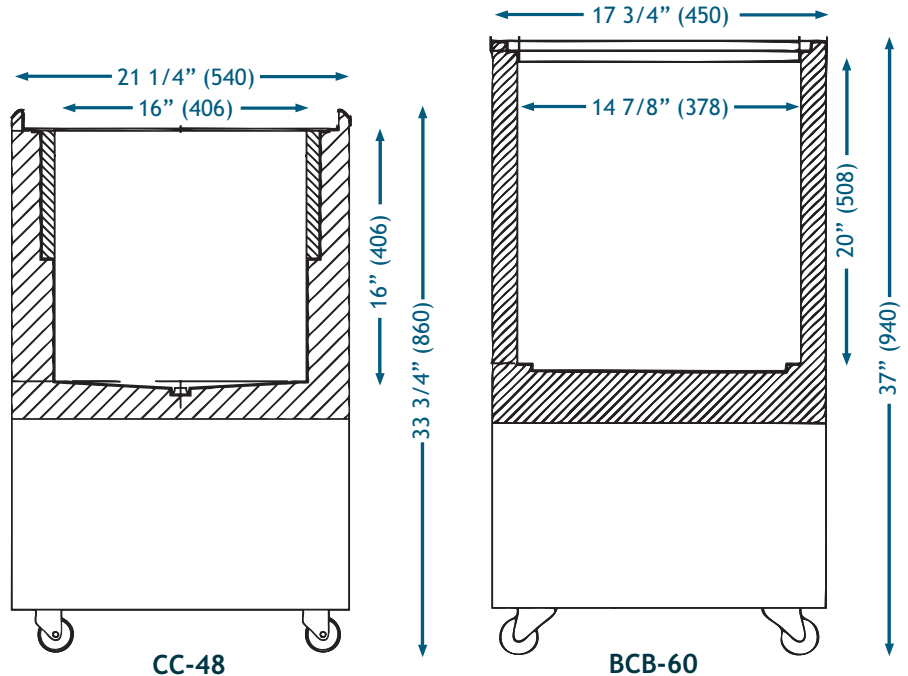

BCB-60 / CC-48



3235 Industry Drive • Suite C
North Charleston, SC 29418
Phone: 843-767-6855
Toll Free: 800-905-4768

Fax: 843-767-6858
Toll Free Fax: 800-906-4768
www.atcgroup.net
sales@atcgroup.net

WARRANTY

One year warranty on all parts and labor and an additional 4 year prorated warranty on compressor.