

Magnum XS 450 -48 Vdc Power System User's Manual



Table of Contents

1	SAFETY FIRST!	1
1.1.	WARNING SYMBOLS	1
1.2.	GENERAL PRECAUTIONS:	1
2	INTRODUCTION	2
2.1.	GENERAL INFORMATION	2
	HOW TO USE THIS MANUAL	4
3	INSTALLATION	5
3.1.	UNPACKING EQUIPMENT	5
3.2.	MECHANICAL INSTALLATION	5
	<i>Room / Location</i>	5
	<i>Mounting</i>	7
	<i>Ventilation</i>	7
3.3.	AC POWER CONNECTIONS	8
	<i>AC Kit with Three Phase Spreader</i>	8
	<i>AC Kit with Phoenix Terminals Only</i>	10
3.4.	RECTIFIER SHELF AND MODULE INSTALLATION	11
	<i>Rectifier Shelf Serial Communications</i>	12
	<i>Rectifier Shelf Mechanical</i>	12
	<i>Rectifier AC Input Connections</i>	12
	<i>Rectifier Module Installation</i>	13
3.5.	DC DISTRIBUTION MODULE INSTALLATION	13
	<i>Module Selection</i>	13
	<i>Merlin Gerin 28 Circuit Breaker Module Installation</i>	14
	<i>Merlin Gerin 12 Circuit Breaker Module Installation</i>	15
	<i>NH2 Fuse Module Installation</i>	16
3.6	DC CABLING GENERAL INSTRUCTIONS	17
3.7	DC DISTRIBUTION INSTALLATION	18
	<i>Circuit Breaker Installation</i>	18
	<i>Installing circuit breakers in a 28 Circuit Breaker Module on the DIN rail</i>	19
	<i>Installing circuit breakers in a 12 CB Module on the DIN rail</i>	20
	<i>Installing circuit breaker wiring (both types of circuit breaker modules)</i>	20
	<i>Installing a fuse in the NH2 Fuse Module</i>	22
	<i>DC Load Return Module Installation</i>	22
	<i>DC Load Return cable connections</i>	23
3.8	BATTERY INSTALLATION	23
	<i>Battery Tray Installation</i>	23
	<i>Battery Installation</i>	23
	<i>Battery Disconnect Module Installation</i>	23
	<i>Negative Battery Cable Connections</i>	24
	<i>Battery Return Module Installation</i>	25
	<i>Positive Battery Cable Connections</i>	25
	<i>Battery Temperature Probe Installation</i>	25
3.9	DC SYSTEM GROUNDING	26
3.10	MONITORING AND RELAY OUTPUT CONNECTIONS	26
	<i>Network Management Card</i>	26
	<i>“Smart” Cable DB9 Connection</i>	27
	<i>RJ45 Ethernet Connector</i>	27

Relay Output Connections.....	27
External Alarm Input Connections.....	28
4 COMMISSIONING.....	29
4.1 PRE-COMMISSIONING INSPECTION	29
Environment.....	29
Electrical Installation.....	29
Battery Visual and Safety Inspection.....	29
4.2 COMMISSIONING.....	30
Initial Set-up.....	30
AC Power Up.....	30
DC Power Up:.....	30
Rectifier Test:.....	30
Battery Power Up.....	30
LVD Test.....	31
Circuit Breaker/ Fuse Test:.....	31
User Inputs.....	31
Output Relay 1:.....	31
Battery Temperature Compensation	31
4.3 FINAL INSPECTION:.....	32
5 OPERATION.....	33
5.1 TECHNICAL DESCRIPTION	33
5.2 RECTIFIER MANAGEMENT	33
AC Input Power.....	33
DC Output Power.....	33
Rectifier alarms reporting.....	33
System Voltage Control	33
Rectifier Current.....	33
5.3 DC DISTRIBUTION	34
DC Distribution Module.....	34
DC Return Module.....	34
5.4 BATTERY MANAGEMENT	34
Battery Disconnect Module.....	34
Battery Return Module.....	34
Battery Shelves.....	34
Battery Cabinet.....	34
5.5 CUSTOMER INTERFACE BOARD	35
Alarm Outputs (Output Relays)	35
External Alarm Inputs (Input Relays).....	35
6 PREVENTIVE MAINTENANCE	36
6.1 EQUIPMENT	36
6.2 INSPECTION	36
Environmental Inspection	36
System Visual and Safety Inspection	36
Battery Visual and Safety Inspection.....	36
6.3 TEST	37
System Voltage Test.....	37
Rectifier Current Test.....	37
Rectifier Current Share Test.....	37
System Current Test.....	37
Rectifier Alarm Test	37

<i>System Temperature Test</i>	38
<i>Battery Current Test</i>	38
<i>Battery Temperature Test</i>	38
<i>LVD Test</i>	38
<i>Battery Preventive Maintenance Procedure</i>	39
6.4 FINAL INSPECTION:.....	39
7 SPECIFICATIONS	40
7.1 AC INPUT DCPM28HN54SH0 RECTIFIER.....	40
7.2 MECHANICAL.....	40
7.3 ENVIRONMENTAL.....	40
7.4 COMPLIANCE.....	41
8 APC WORLDWIDE CUSTOMER SUPPORT	42
9 LIMITED PRODUCT WARRANTY	43

Entire contents copyright © 2003 American Power Conversion. All rights reserved. Reproduction in whole or in part without permission is prohibited. APC and the APC logo are trademarks or registered trademarks of American Power Conversion Corporation. All other trademarks, product names, and corporate names are the property of their respective owners and are used for informational purposes only

Revision History

Revision	Date	By	Description
990-1557 Revision 1	20 Oct, 2003	JPF	Initial Release
990-1557A Revision 2	30 MAR 2004	BET	Update to include Battery Cabinet

Table of Figures

FIGURE 2.1-1 MAGNUM XS 450 POWER PLANT	2
FIGURE 2.1-2 POWER SYSTEM BLOCK DIAGRAM	3
FIGURE 3.2-1 DOOR CLEARANCE DIMENSIONS	6
FIGURE 3.2-2 FLOOR MOUNTING DIMENSIONS	7
FIGURE 3.3-1 AC KIT WITH THREE PHASE SPREADER (SHOWN WITH SINGLE POLE BREAKERS)	9
FIGURE 3.3-2 RECOMMENDED TORQUES ON INPUT CONNECTORS.....	10
FIGURE 3.3-3 RECOMMENDED TORQUES FOR TERMINAL BLOCK CONNECTIONS.....	10
FIGURE 3.3-4 AC INPUT ENTRY WITH INDIVIDUAL RECTIFIER ENTRY (SHOWN WITH SINGLE POLE CIRCUIT BREAKER OPTION).....	11
FIGURE 3.4-1 RECTIFIER SWITCH SETTINGS	12
FIGURE 3.4-2 RECOMMENDED TORQUES ON RECTIFIER CONNECTORS	12
FIGURE 3.5-1 28 CIRCUIT BREAKER MODULE	14
FIGURE 3.5-2 12 CIRCUIT BREAKERS MODULE.....	16
FIGURE 3.5-3 NH2 FUSE MODULE	17
FIGURE 3.7-1 MERLIN GERIN CIRCUIT BREAKER.....	18
FIGURE 3.7-2 MERLIN GERIN 28 CB MODULE INSTALLATION DETAIL	19
FIGURE 3.7-3 MERLIN GERIN 12 CB MODULE INSTALLATION DETAIL	20
FIGURE 3.7-4 CB ALARM INTERFACE BOARD (28 CIRCUIT BREAKER MODULE).....	21
FIGURE 3.7-5 CB ALARM EXPANSION BOARD (12 CIRCUIT BREAKER MODULE).....	21
FIGURE 3.7-6 NH2 FUSE CONNECTIONS	22
FIGURE 3.7-7 LARGE LOAD AND SMALL LOAD RETURN MODULE	23
FIGURE 3.8-1 BATTERY CABLE CONNECTIONS	24
FIGURE 3.8-2 BATTERY RETURN MODULE	25
FIGURE 3.8-3 TYPICAL LOCATION OF BATTERY TEMPERATURE PROBE	26
FIGURE 3.10-1 NETWORK MANAGEMENT CARD.....	26

1 Safety First!

It is very important to follow all safety procedures when unpacking, installing and operating any sort of power equipment.

1.1. Warning Symbols

	CAUTION: An indication that special care is required to prevent injury, equipment damage or misuse
---	---

	WARNING: An indication of an electrical hazard that may cause serious personal injury or death, catastrophic equipment damage or site destruction.
---	---

1.2. General Precautions:

	WARNING: Hazardous ac voltage levels are present inside the power system. Keep the ac input cover in place when the system is operational or energized.
---	--

	WARNING: Hazardous energy levels are present on bare conductors in the -48Vdc distribution connection area of the plant. Accidental shorting of distribution conductors can cause arcing and high currents that can cause serious burns or other physical harm. It is recommended that: <ul style="list-style-type: none">• Remove any jewelry, rings or watches while working on this equipment.• Use insulated wrenches, screwdrivers, cutters, pliers and other tools.
---	---

	WARNING: Ensure that all of the dc and external ac circuit breakers are in the OFF position prior to connecting service to the power plant. Confirm that all voltages have been removed including any battery sources before proceeding.
---	---

Specific **CAUTION** and **WARNING** will be placed in manual where appropriate.

2.1. General Information

DC Power Plants from APC have unique features that make them easy to install, maintain, and upgrade. The rectifier units are modular and truly “hot-pluggable” into the shelf assembly without any separate ac wiring. The shelf assemblies are also modular and can be added when system capacity needs to be expanded. All system settings are made from the system controller that provides monitoring and control functions for each component of the system as well as alarm listings for system diagnosis and maintenance.

The APC Magnum XS 450 Power System is a modular stand-alone -48V dc power plant. It is configurable in such a manner that it will support most typical applications within the specified current range without special application engineering or assistance. A wide variety of dc output distribution and battery disconnect modules are supported. An optional low voltage disconnect (LVD) can be provided on either the battery or the load side. A 450-ampere system is shown in Figure 2.1-1. A block diagram of a typical configuration of the power system is shown in Figure 2.1-2.

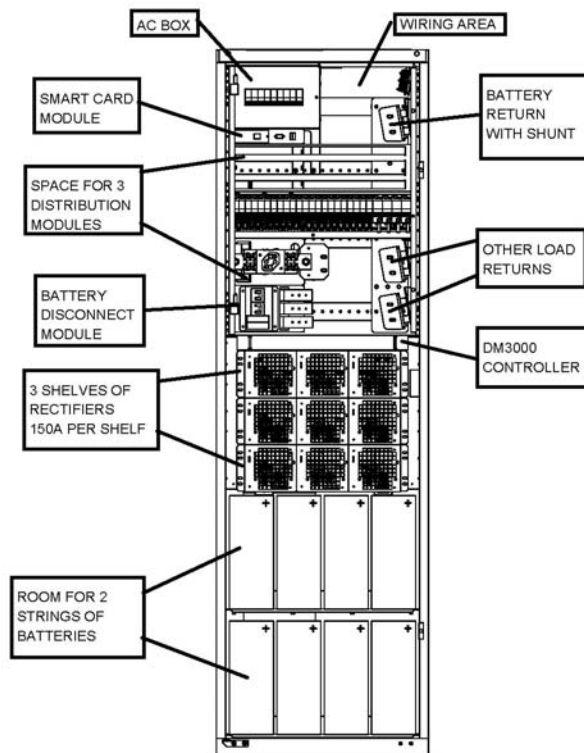

Figure 2.1-1 Magnum XS 450 Power Plant

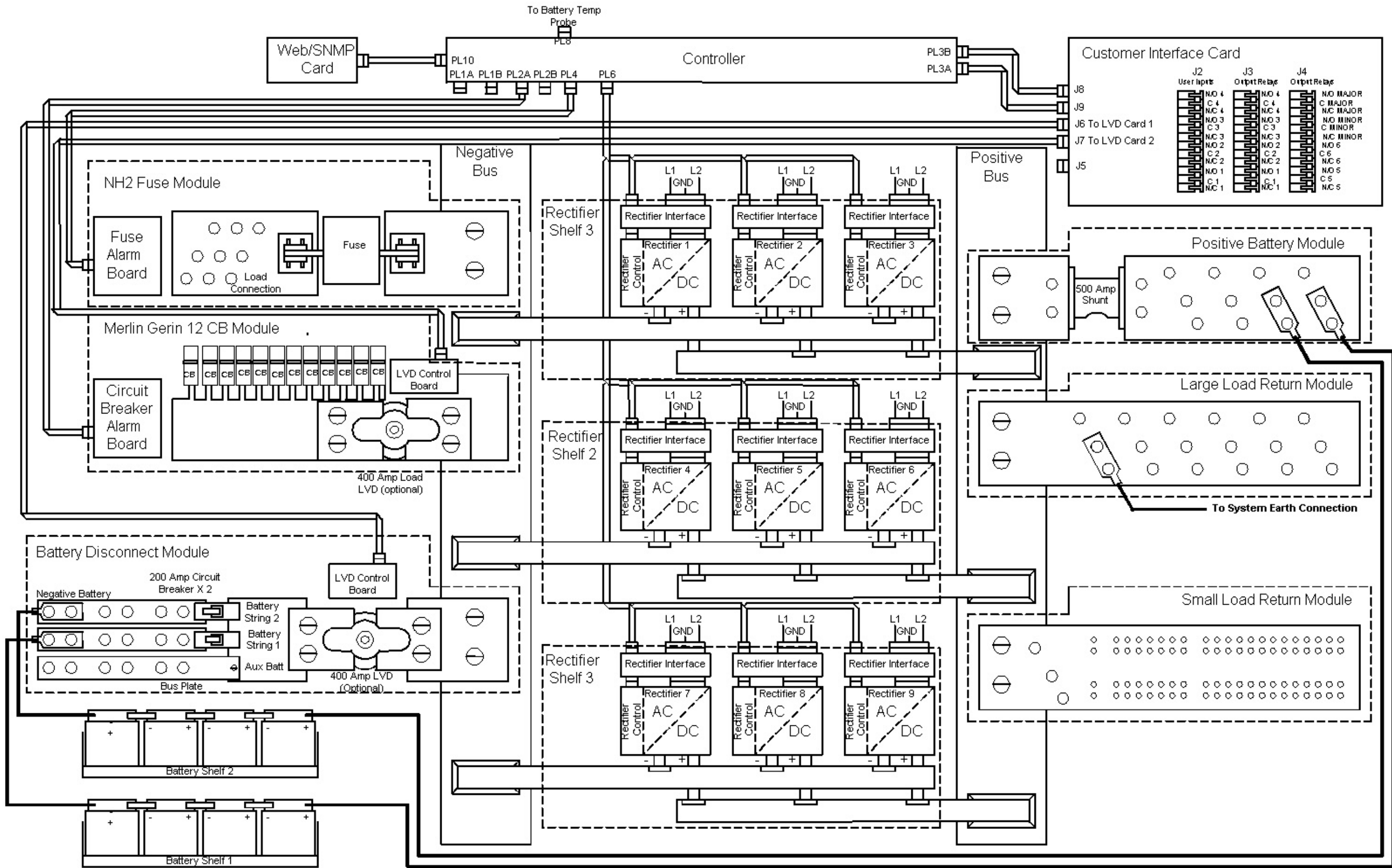

Figure 2.1-2 Power System Block Diagram

How to Use This Manual

Each section of this manual can be read in any order and should provide a complete explanation of the subject described by the title. However, the sequence of the sections is designed to provide a typical step-by-step process for successful use of the equipment.

<i>Safety First!</i>		Safety symbol description and general precautions.
<i>Introduction</i>		Brief system preview and explanation of manual usage.
<i>Installation</i>		How to unpack and install the equipment.
<i>Commissioning</i>		The procedure for commissioning the equipment for initial use
<i>Operation</i>		Specifics of controls settings and indicators used to operate the unit.
<i>Preventative Maintenance</i>		Procedures for performing preventative maintenance on the equipment.
<i>Specifications</i>		Power plant and rectifier specifications.
<i>APC Worldwide Customer Support</i>		How to contact APC for customer support.
<i>Warranty</i>		Equipment warranty terms and conditions.

3.1. Unpacking Equipment

Remove equipment from packing material and inspect for shipping damage or missing items. It is important to report damage or material shortages to the shipping carrier while a representative is on site.

If concealed damage or material shortages are found at a later time, contact the shipper to make arrangements for inspection and claim filing. Refer to **Section 7** in the event it is necessary to return equipment to APC.



CAUTION: Appropriate lifting techniques and safety equipment should be used to remove equipment from packing.



PLEASE RECYCLE: The shipping materials can be recycled. Please save them for later use or dispose accordingly.

3.2. Mechanical Installation

Room / Location

NOTE: The APC Magnum XS 450 Power System is to be installed in a room, vault, or similar enclosure that is accessible only to qualified persons in accordance with the local regulatory authority.

Prior to installation, drawings, floor loading requirements, external alarm points, ac service entrance, and grounding schemes should all be checked and confirmed. If batteries are to be mounted in a room separate from the power plant, careful attention should be paid to battery cable voltage drop effects. Environmental operating temperatures and ventilation/cooling considerations should also be noted, not just for the power system but also for all other equipment that may reside in the power room area.

The power system has a door on the front that can be hinged to swing either way. The power system has two doors on the rear that swing out. The doors have spring loaded hinge pins so that they can be removed for servicing. Dimensions are shown in Figure 3.2-1. The sides have panels that are mounted flush with the frame. A key-lock on the top of the panels holds the panels in place.

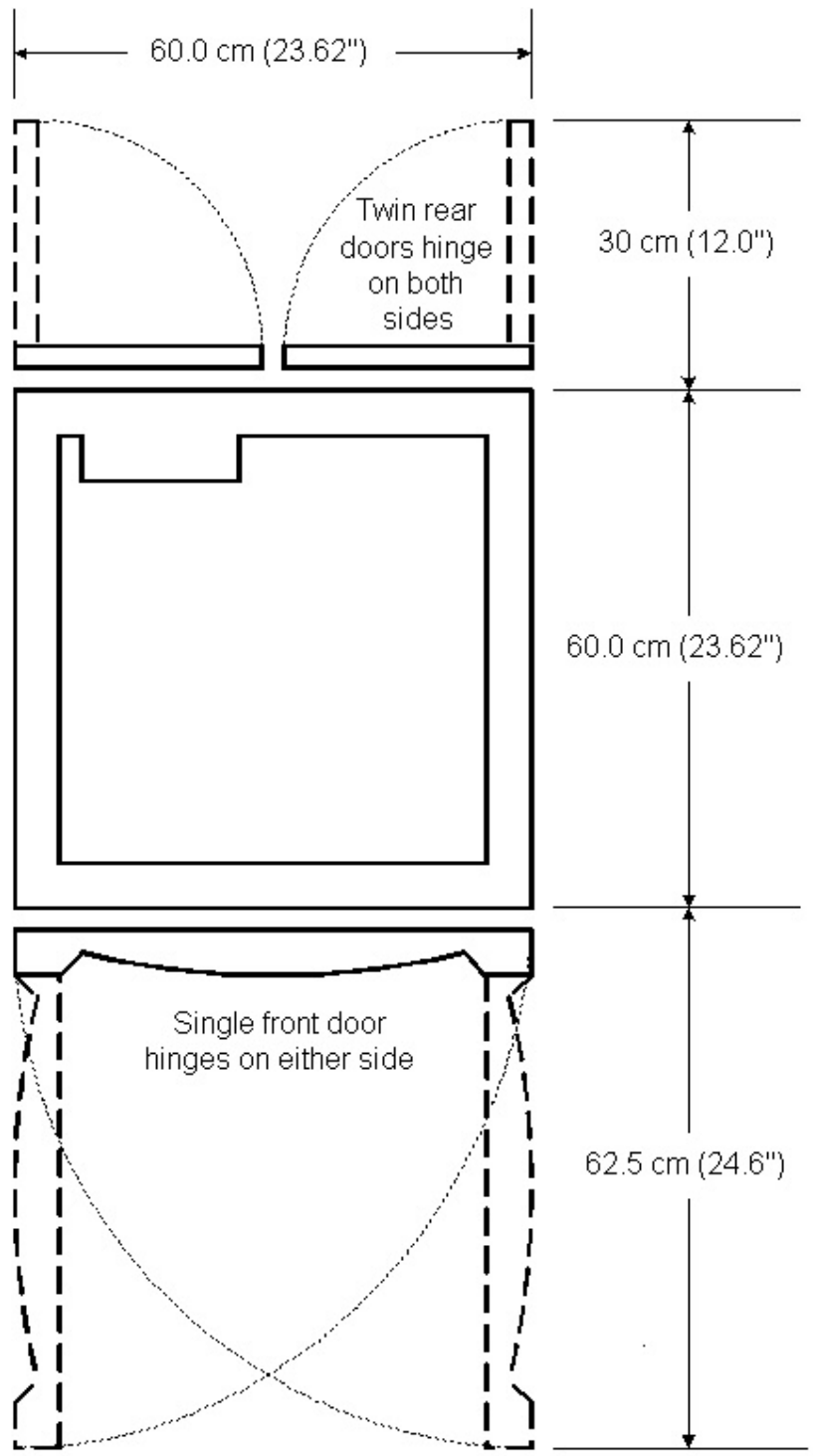

Figure 3.2-1 Door Clearance Dimensions

Mounting

The unit is self-supporting, but designed to be bolted to the floor of the housing structure. Figure 3.2-2 shows the footprint of the box frame and the mounting points with dimensions.

Systems with multiple box frames are bolted together with each frame touching, side by side. The side panels where two frames touch are removed so that cables can pass between the frames. A kit with the necessary hardware to bolt two cabinets together (0M-3441) is available from APC.

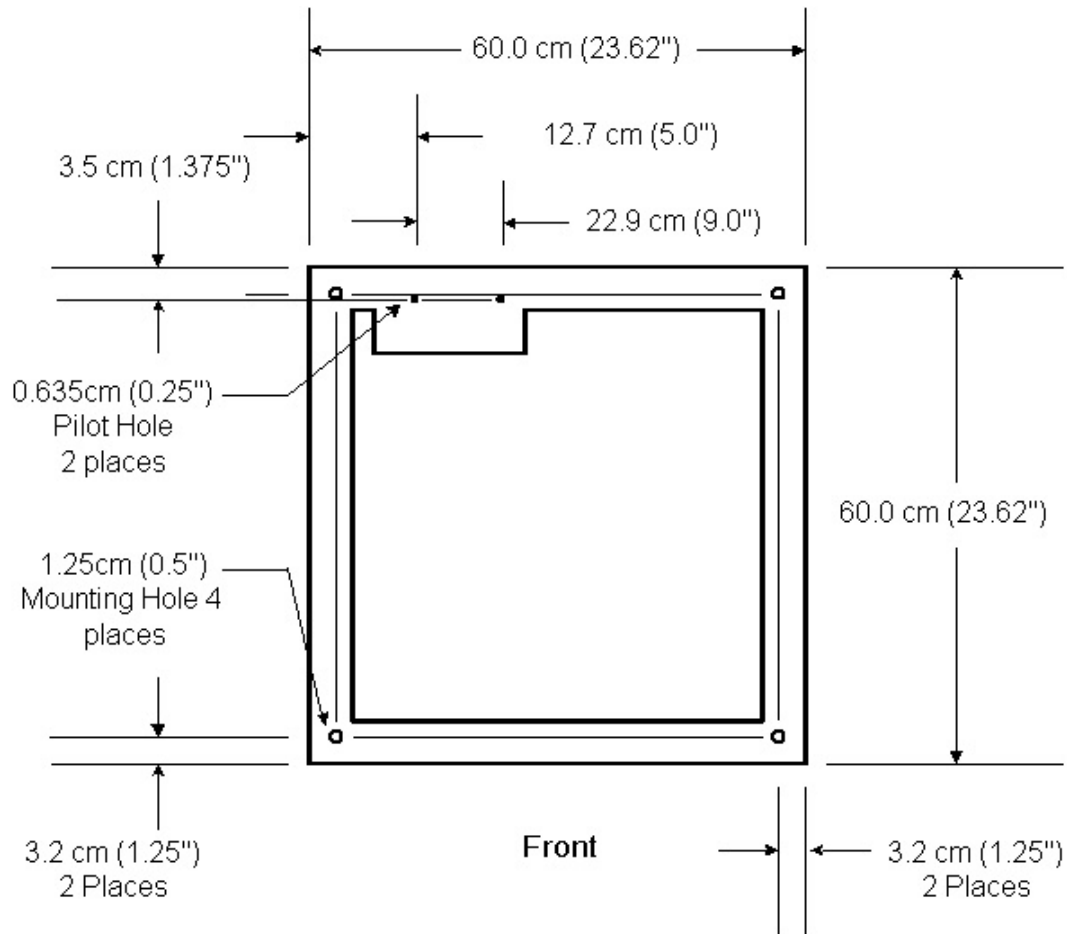

Figure 3.2-2 Floor Mounting Dimensions

Ventilation

The rectifier modules for this system have fans that provide front-to-rear airflow for internal cooling. The Magnum XS 450 Power System frame should be mounted such that there is free airflow to the front and rear of the unit. [Refer to **Section 7.3** for environmental characteristics.] Free airflow should be ensured so that the power system can provide full power at ambient temperature without de-rating.

3.3. AC Power Connections



WARNING: Ensure that all of the external dc and ac circuit breakers are in the OFF position prior to connecting service to the power plant. Confirm that all voltages have been removed including any battery sources before proceeding.

The Magnum XS 450 Power System requires the supply of a nominal 230 Vac single-phase, or three-phase 415/230 V, 50/60 Hz power to the ac input terminal block connections. However, it will operate off of voltages in the range of 176 – 293 V. The maximum possible dc Current Output of the rectifiers is less than the typical value of 50A per rectifier at ac input voltages in the range of 176 to 195 Vac. As the ac input voltage decreases, the maximum dc Output current follows a de-rating curve. For further details on the de-rating curve, please refer to the specification sheet for the DCPM28HN54SH0 Rectifier available from APC Customer service in your area or your local APC distributor.

The ac input enclosure is located at the top of the Magnum XS 450 Power System housing. AC wiring, from the ac input terminal block connections to the hot-pluggable ac input connector for each rectifier, is factory installed. An ac branch circuit breaker of 50 A is recommended for each phase if using the three phase set-up. An ac branch circuit breaker of 20A is recommended for each single-phase connection.



WARNING: Hazardous ac voltage levels are present inside the power system. Keep the ac input cover in place when the system is operational or energized.

AC Kit with Three Phase Spreader

A terminal block for connection of ac input power and “Earth Ground” is provided. The terminal block is labeled as E, NEUT, L1, L2 and L3. At the front of the ac input enclosure, either single pole or two pole circuit breakers are provided for each rectifier. The single pole option breaks the “hot” wire going to each individual circuit breaker. The two-pole breaker option simultaneously breaks both the “hot” wire and the Neutral wire.

The top of the ac input enclosure is provided with four pilot holes for easy alignment of the desired conduit entry holes. A duct is provided so that the ac input connections can be routed up through the unit from the bottom. Two 31.75 mm (1-1/4 inch) conduit entry holes are provided in the bottom of the cabinet.

When a single three phase ac input line is run to each system, a large line spreader strip is provided for connection of the ac Input. The suggested wire size for the Neutral and Ground lines are 35 mm² (#2 AWG) rated at 90°C or higher. The suggested wire size for the lines is 16 mm² (#6 AWG) rated at 90°C or higher; however, the ambient temperature and number of wires in a conduit must also be considered in accordance with all applicable code requirements.

If the ac input power is provided from a three-phase distribution panel. The left rectifier in each shelf is powered from the terminal block labeled L1. The middle rectifier in each shelf is

powered from the terminal block labeled L2. The right rectifier in each shelf is powered from the terminal block labeled L3.

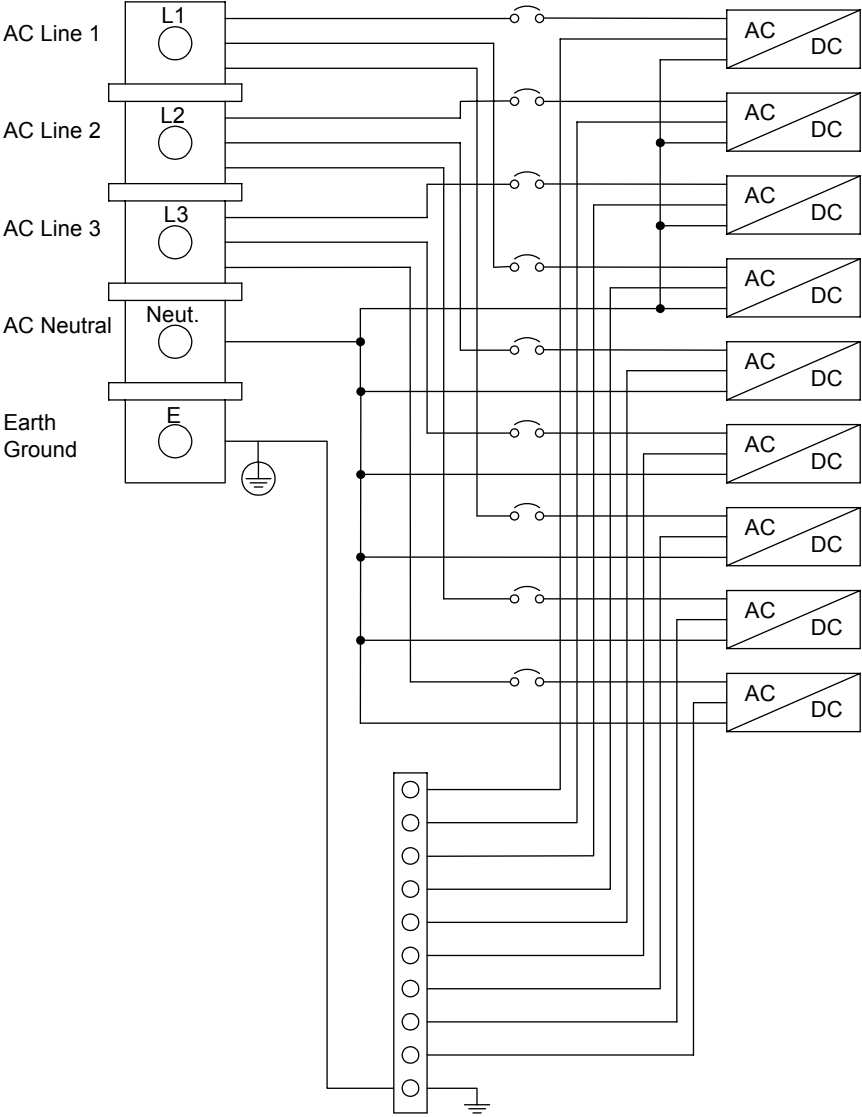

Figure 3.3-1 AC Kit with Three Phase Spreader (shown with single pole breakers)

Neutral Input			
Wire Size (AWG)	Wire Size (mm ²)	Max Torque (in-lb)	Max Torque (N-m)
350 kcmil – 2 Cu	185 – 35 Cu	275	31.75
L1, L2, and L3 Input			
Wire Size (AWG)	Wire Size (mm ²)	Max Torque (in-lb)	Max Torque (N-m)
2/0 – 6 Cu	70-16 Cu	125	13.5
Earth Ground Input			
Wire Size (AWG)	Wire Size (mm ²)	Max Torque (in-lb)	Max Torque (N-m)
4/0 – 6 Cu	95 – 16 Cu	275	31

Figure 3.3-2 Recommended Torques on Input Connectors

AC Kit with Phoenix Terminals Only

A terminal strip for ac input power connection and a separate “Earth Ground” bar for connection of the safety ground wire(s) is provided. The terminal block is labeled as L and N for each rectifier with the terminal block for rectifier one being the leftmost. At the front of the ac input enclosure, optional single pole or two pole circuit breakers may be provided for each rectifier. The single pole option breaks the “hot” wire going to each individual circuit breaker. The two-pole breaker option simultaneously breaks both the “hot” wire and the Neutral wire. The system may also have no circuit breakers.

The top of the ac input enclosure is provided with four pilot holes for easy alignment of the desired conduit entry holes. A duct is provided so that the ac input connections can be routed up through the unit from the bottom. Two 31.75 mm (1-1/4 inch) conduit entry holes are provided in the bottom of the cabinet.

Individual ac input lines are run for each rectifier. The suggested wire size is 6 mm² (#10 AWG) rated at 90°C or higher, however, the ambient temperature and number of wires in a conduit must also be considered in accordance with all applicable code requirements.

Wire Size (AWG)	Wire Size (mm ²)	Max Torque (in-lb)	Max Torque (N-m)
6 - 10 Cu	16 –6	16	1.8

Figure 3.3-3 Recommended Torques for Terminal Block Connections

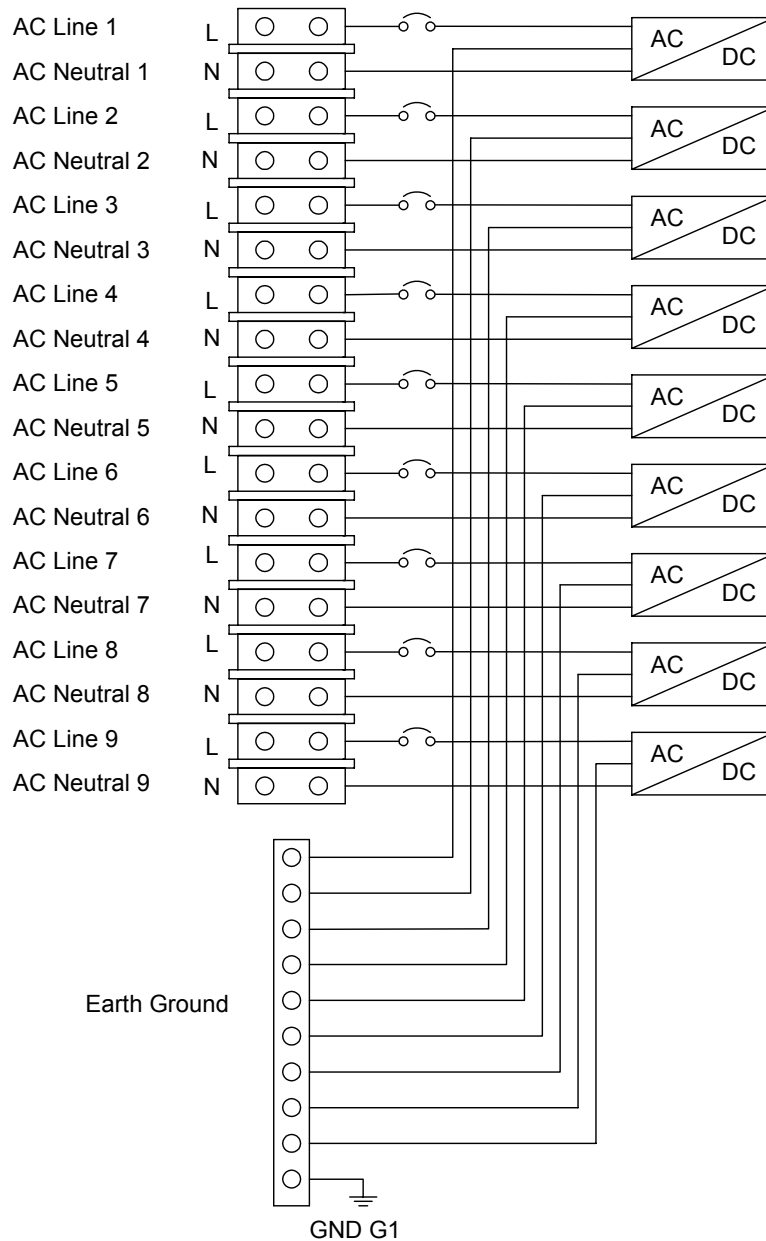



Figure 3.3-4 AC Input Entry with Individual Rectifier Entry (shown with single pole circuit breaker option)

3.4. Rectifier Shelf and Module Installation

Since expandability is so important, rectifiers and rectifier shelves are very easy to install. A rectifier shelf will hold up to 3 rectifiers. There is individual ac input wiring for each rectifier. Each rectifier will communicate to the controller through a ten-pin ribbon cable.

	<p>WARNING: Ensure that all of the ac circuit breakers for any rectifier shelf to be added are in the OFF position prior to installing the additional shelf/shelves.</p>
---	---

Rectifier Shelf Serial Communications

Program the binary address of each rectifier in the shelf using S1 on the rectifier interface card. These are located at the back of each rectifier slot. All switches ON will give an address of zero (rectifier 1). Set switches per the following table:

	S1 Switch Position							
	Address 1	Address 2	Address 3	Address 4	Address 5	Address 6	Address 7	Address 8
Rectifier 1	ON	ON	ON	ON	ON	ON	ON	ON
Rectifier 2	OFF	ON	ON	ON	ON	ON	ON	ON
Rectifier 3	ON	OFF	ON	ON	ON	ON	ON	ON
Rectifier 4	OFF	OFF	ON	ON	ON	ON	ON	ON
Rectifier 5	ON	ON	OFF	ON	ON	ON	ON	ON
Rectifier 6	OFF	ON	OFF	ON	ON	ON	ON	ON
Rectifier 7	ON	OFF	OFF	ON	ON	ON	ON	ON
Rectifier 8	OFF	OFF	OFF	ON	ON	ON	ON	ON
Rectifier 9	ON	ON	ON	OFF	ON	ON	ON	ON

Figure 3.4-1 Rectifier Switch Settings

Plug the 10-pin ribbon cable supplied with the rectifier shelf into J2 of each rectifier interface card in the shelf. Plug the 10-pin ribbon cable into the 10-pin ribbon cable that goes down the back of the power system.

Rectifier Shelf Mechanical

Install the rectifier shelf from the front, holding the shelf horizontal. Align the rear shelf alignment slot with the alignment stud on the side box supports on both sides of the shelf. Hold the shelf horizontally to ensure the proper mating of the shelf bus with the rear bus clips. The shelf may now be pushed to the rear until the shelf flanges are flat against the front box support. Ensure that the shelf rear bus and the rear bus clips are properly mated. Install 4 M5 machine screws to secure the front of the shelf to the power bay.

Rectifier AC Input Connections

Each rectifier interface card on the shelf has a 3-pin connector J1 for the ac input to that rectifier. Insert the mating connector from the ac cable assembly into J1. Route the wires up to the ac input assembly. Connect the green/yellow wire from the ac cable assembly to the Ground connection in the ac input assembly. If two pole rectifier circuit breakers are installed, connect the red and the black wire from the ac cable assembly to the circuit breaker. If single pole rectifier circuit breakers are installed, connect the red wire from the ac cable assembly to the circuit breaker. Connect the black wire to the ac input terminal strip. If no rectifier circuit breakers are installed, connect the red and the black wire to the ac input terminal strip.

Wire Size (AWG)	Wire Size (mm ²)	Max Torque (in-lb)	Max Torque (N-m)
10 - 14 Cu	6 – 2.5 Cu	20	2.25

Figure 3.4-2 Recommended Torques on Rectifier Connectors

Rectifier Module Installation



WARNING: Rectifier dc output circuits would be damaged if battery were installed incorrectly. Before rectifier installation, ensure proper battery polarity.

Rectifier modules are hot-swappable. The rectifier modules are generally shipped in separate containers. Remove the rectifier from its shipping container. Using a flat blade screwdriver, loosen the pawl latch (counter-clockwise) on the rectifier, until the latch is recessed inside the rectifier. Slide the rectifier module into the shelf between the guides until it is fully seated. Tighten the rectifier pawl latch (clockwise). The pawl latch is a multi-turn device and should be turned until the latch holds the rectifier snugly. Since all adjustments are made from the system control unit, no rectifier adjustments are necessary.



CAUTION: Rectifier fan inlet filters are available for dusty or hostile environments. Failure to periodically check and clean filters can lead to rectifier shutdown due to over temperature and produce power plant failure.

Fan inlet filters are available for order from APC (Part Number 1MAF28).

3.5. DC Distribution Module Installation

Module Selection

A variety of dc distribution modules are available. These modules are designed to provide a convenient means of attaching the dc load cables. These modules also provide over-current protection, low voltage disconnect and/or load shed capability. The modules that are attached to the 54-volt return bus bars are designed to provide a convenient means of attaching the dc return cables.

SKU Number	Description	LVD Option	Qty Allowed in System
0M-2189	Merlin Gerin 12 Circuit Breaker	No LVD	3
0M-2188	Merlin Gerin 12 Circuit Breaker	400 A LVD	3
0M-2185	NH2 Fuse	No LVD	3
0M-2187	NH2 Fuse	400 A LVD	3
0M-2186	Merlin Gerin 28 Circuit Breaker	No LVD	1
0M-2579	Merlin Gerin 28 Circuit Breaker	400 A LVD	1

Table 3.5-1 DC Distribution Module Selector Table

Merlin Gerin 28 Circuit Breaker Module Installation



WARNING: Hazardous energy levels are present on bare conductors in the -48Vdc distribution connection area of the plant. Accidental shorting of distribution conductors can cause arcing and high currents that can cause serious burns or other physical harm. It is recommended that:

- Remove any jewelry, rings or watches while working on this equipment.
- Use insulated wrenches, screwdrivers, cutters, pliers and other tools.

The Merlin Gerin 28 Circuit Breaker Module requires two adjacent open module positions. The wiring support bracket is mounted directly above the Merlin Gerin 28 Circuit Breaker module. Position the wiring support bracket in the top open position. Use M5 hardware to secure the front lip of the wiring support bracket above the to the power system frame. Connect the two alarm cables to the controller backplane.

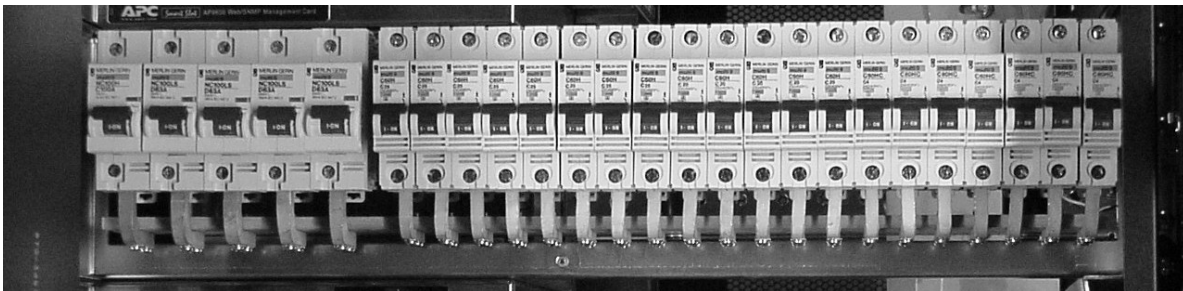

Figure 3.5-1 28 Circuit Breaker Module

Position the circuit breaker module below the wiring support bracket. Insert the module in the power system such that the holes in the module dc bus line up with the holes in the power system dc bus. Use M8 hardware to secure the buses together. Use M5 hardware to secure the front lip to the power system frame. Use M6 hardware to secure the rear of the module to the power system frame.

Connect the LVD power wiring to the power bus observing proper polarity. Connect the LVD control cable to the customer interface card.

The alarm signal of each individual circuit breaker [see **Installing circuit breaker wiring (both types of circuit breaker modules)** for specific alarm cable wiring instructions] is connected to a terminal block on the CB Interface Board (mounted directly above the circuit breaker module). Each alarm wire is placed in the terminal block position with the number corresponding to the position of the circuit breaker in the system. The CB Interface Board is connected to the controller via a 50-conductor cable that plugs into the J3 connector on the CB Interface Board. The 50-conductor cable splits into (2) DB-25 connectors that plug into connectors PL1A and PL1B on the controller backplane.

Merlin Gerin 12 Circuit Breaker Module Installation



WARNING: Hazardous energy levels are present on bare conductors in the -48Vdc distribution connection area of the plant. Accidental shorting of distribution conductors can cause arcing and high currents that can cause serious burns or other physical harm. It is recommended that:

- Remove any jewelry, rings or watches while working on this equipment.
- Use insulated wrenches, screwdrivers, cutters, pliers and other tools.

The Merlin Gerin 12 Circuit Breaker Module requires one open module position. Insert the module in the power system such that the holes in the module dc bus line up with the holes in the power system dc bus. Use M8 hardware to secure the buses together. Use M5 hardware to secure the front lip to the power system frame. Use M6 hardware to secure the rear of the module to the power system frame. Connect the alarm cable to the controller backplane.

Connect the LVD power wiring to the power bus observing proper polarity. Connect the LVD control cable to the customer interface card.

The alarm signal of each individual circuit breaker [see **Installing circuit breaker wiring (both types of circuit breaker modules)** for specific alarm cable wiring instructions] is connected to a terminal block on the CB Extender Board (mounted directly above the circuit breaker module). Each alarm wire is placed in the terminal block position with the number corresponding to the position of the circuit breaker in the system. The CB Extender Board (mounted directly above the circuit breaker module) is connected to the controller via a 26-conductor cable that plugs into the J2 connector on the CB Extender Board. The 26-conductor cable has a DB-25 connector on the other end that plugs into connector PL2A on the controller backplane. The DB-25 end of the cable is only 25 pins, so the 26th conductor is not connected to this connector.

If a second 12 Circuit Breaker module is installed in a system, then the CB Extender Board for that module is connected via a 26 pin connector from connector J2 to connector J3 of the CB Extender Board of the first 12 Circuit Breaker module. If a third 12 Circuit Breaker Module is installed in the system, it is connected to the controller via a 26-conductor cable that plugs into the J2 connector on the CB Extender Board. The other end of the 26-conductor cable has a DB-25 connector that plugs into connector PL2B on the controller backplane board.

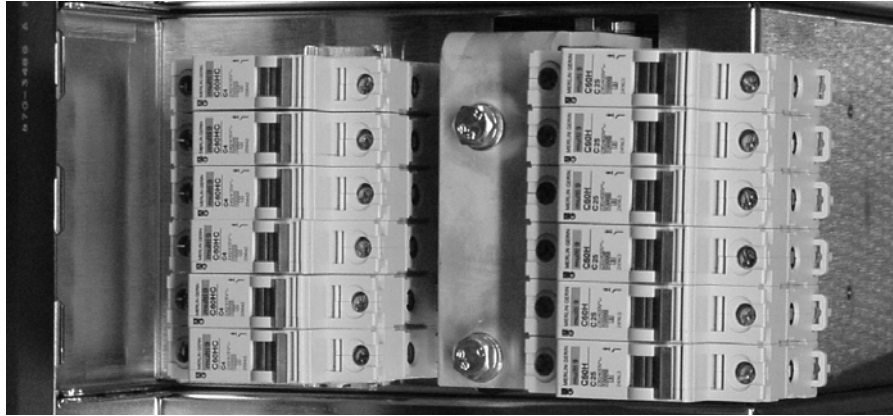



Figure 3.5-2 12 Circuit Breakers Module

CIRCUIT BREAKER RATING	ORDERING NUMBER
Merlin Gerin C60HC 4 A	0M-3318
Merlin Gerin C60HC 10 A	0M-3314
Merlin Gerin C60HC 20 A	0M-3315
Merlin Gerin C60HC 32A	0M-3316
Merlin Gerin C60HC 40A	0M-3317
Merlin Gerin C60HC 50A	0M-3319
Merlin Gerin C60HC 63A	0M-3311
Merlin Gerin C120HC 80A	0M-3313
Merlin Gerin C120HC 100A	0M-3312
Merlin Gerin C120HC 125A	0M-3310

Table 3.5-2 Circuit Breakers Available from APC

NH2 Fuse Module Installation

	<p>WARNING: Hazardous energy levels are present on bare conductors in the -48Vdc distribution connection area of the plant. Accidental shorting of distribution conductors can cause arcing and high currents that can cause serious burns or other physical harm. It is recommended that:</p> <ul style="list-style-type: none"> • Remove any jewelry, rings or watches while working on this equipment. • Use insulated wrenches, screwdrivers, cutters, pliers and other tools.
---	---

The NH2 Fuse Module requires one open module position. Insert the module in the power system such that the holes in the module dc bus line up with the holes in the power system

dc bus. Use M8 hardware to secure the buses together. Use M5 hardware to secure the front lip to the power system frame. Use M6 hardware to secure the rear of the module to the power system frame.

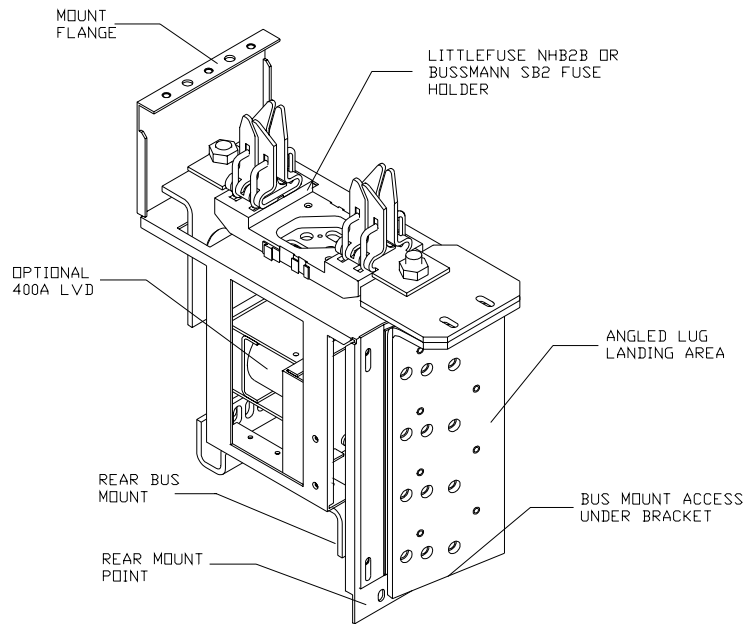

Figure 3.5-3 NH2 Fuse Module

Connect the LVD power wiring to the power bus observing proper polarity. Connect the LVD control cable to the customer interface card.

The alarm signal of each individual fuse is connected from a ring terminal secured to the fuse module with a 5mm screw placed in one of the threaded holes provided on the load side of the fuse module. The other end of each alarm wire is connected to the terminal block position on the Fuse Interface Board with a number corresponding to the position of the fuse in the system. The Fuse Interface Board connects to the controller via a 16 conductor to DB-25 cable that connects to connector PL4 on the controller backplane board.

FUSE RATING	ORDERING NUMBER
100 A fuse	0M-3390
200 A fuse	0M-3393
300 A fuse	0M-3392
400 A fuse	0M-3391

Table 3.5-3 NH2 Style Fuses Available from APC

3.6 DC Cabling General Instructions

It is very important to keep load cabling separate from battery cabling. For example, hooking load cables to a module used as battery disconnect will tie the battery directly to the load.

Hooking the load cables to a module used as a battery return will cause erroneous battery current readings.

The dc load cable(s) should be sized to limit the voltage drop from the Magnum XS 450 Power System to the loads per system design requirements. The cable(s) must also carry the full load current during battery operation. During battery operation the voltage will be lower and for constant power loads the current will typically be higher. If assistance is required to determine the necessary cables for the application, contact your sales representative or APC.

3.7 DC Distribution Installation

	<p>WARNING: Hazardous energy levels are present on bare conductors in the -48 Vdc distribution connection area of the plant. Accidental shorting of distribution conductors can cause arcing and high currents that can cause serious burns or other physical harm. It is recommended that:</p> <ul style="list-style-type: none">• Remove any jewelry, rings or watches while working on this equipment.• Use insulated wrenches, screwdrivers, cutters, pliers and other tools.
---	---

Circuit Breaker Installation

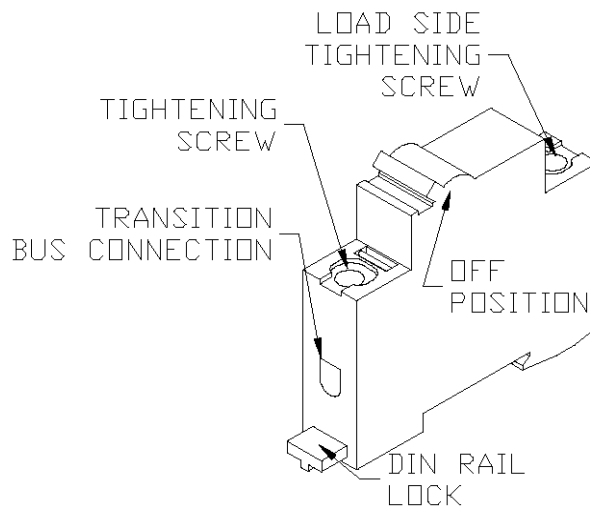



Figure 3.7-1 Merlin Gerin Circuit Breaker

	<p>WARNING: The circuit breakers (CBs) should be in the OFF position prior to installation in the system.</p>
---	--

Installing circuit breakers in a 28 Circuit Breaker Module on the DIN rail

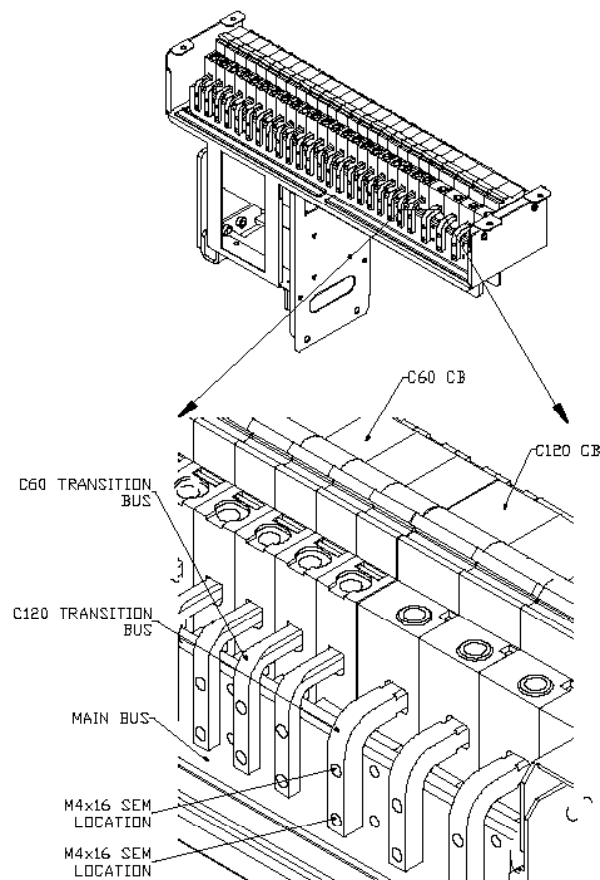

Figure 3.7-2 Merlin Gerin 28 CB Module Installation Detail

Install the Merlin Gerin Circuit Breaker (CB) to the mounting DIN Rail on the 0M-2186 or 0M-2579 circuit breaker module with the DIN rail lock positioned toward the main bus. The C60 style CBs should be installed from left to right on the main bus and the C120 style CBs should be installed from right to left on the main bus for the best use of the main bus positions.

Enable the CB's DIN rail lock (the CB may still be moved laterally on the DIN rail for final positioning). Position the appropriate transition bus on the main bus and inserted in the opened CB connection area. Secure the transition bus to the main bus with the two M4x16 machine screws (SEMs) provided. Tighten the CB connection tightening screw on the transition bus.

Any combination of up to 28 Merlin Gerin circuit breakers may be installed on the 28 circuit breaker module. There are two different types of circuit breaker available: the C60 series circuit breaker and the C120 series circuit breakers. The two basic types of Merlin Gerin circuit breakers may be installed in combination as shown in the table below.

C60	28	26	25	23	22	20	19	17	16	14
C120	0	1	2	3	4	5	6	7	8	9
Total	28	27	27	26	26	25	25	24	24	23
C60	13	11	10	8	7	5	4	2	1	0
C120	10	11	12	13	14	15	16	17	18	19
Total	23	22	22	21	21	20	20	19	19	19

Table 3.7-1 Circuit Breaker Mix Table

Installing circuit breakers in a 12 CB Module on the DIN rail

Install the C60 style Merlin Gerin Circuit Breaker to the mounting DIN Rail on the 0M-2188 or 0M-2189 module with the DIN rail lock positioned toward the bus finger. Open the bus connection by loosening the bus side tightening screw. Open the DIN rail lock. Slide the CB onto the bus finger until the front edge of the CB clears the edge of the DIN rail. Lower the front edge of the CB onto the DIN rail and slide the CB back until the edge of the DIN rail fully enters the CB rail slot #1. Lower the rear of the CB onto the DIN rail. Slide the CB forward slightly to seat rail slot #2. Engage the CB DIN rail lock. Tighten the CB connection screw on the bus finger.

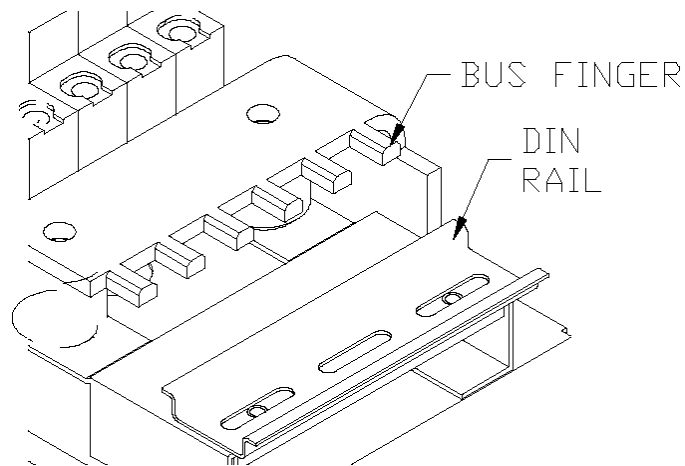

Figure 3.7-3 Merlin Gerin 12 CB Module Installation Detail

Installing circuit breaker wiring (both types of circuit breaker modules)

Insert the load wire and the flat spade of the alarm cable into the open load side of the CB. Tighten the CB load side tightening screw. Route the alarm cable to the alarm PWB (trim the wire length as required and strip the end of the wire approximately ¼ inch (6mm)). Insert a small bladed screwdriver into the small opening above the desired position and then insert the stripped alarm that has been cut to length. Remove the screwdriver to capture the alarm lead. Label the circuit breaker as desired using the label kit provided with the module. Dress the load wire and the alarm cable as required to the lead support bracket.

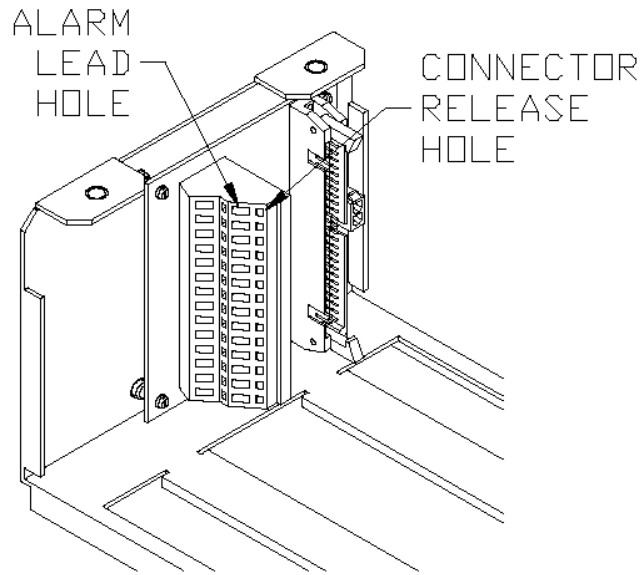

Figure 3.7-4 CB Alarm Interface Board (28 circuit breaker module)

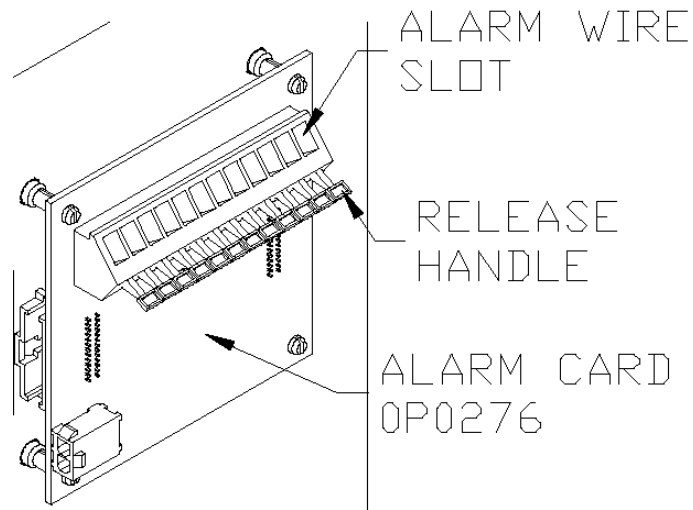

Figure 3.7-5 CB Alarm Expansion Board (12 circuit breaker module)

Installing a fuse in the NH2 Fuse Module

Insert the fuse into the fuse module until the tangs on each end of the fuse bottom out in the socket.



Figure 3.7-6 NH2 Fuse Connections

DC Load Return Module Installation

The modules that are attached to the Return bus are designed to provide a convenient means of attaching the dc return cables. The battery return module has a shunt installed and the load return modules do not. Table 3.7- will assist you in selecting the correct load return module.

Part Number	Description	Lug Size	Number of Connections
0M-2969	Small Load Return Bus	M5 threaded holes on 1.59 mm (5/8 in.) centers.	40 M5; 1 set of M8 holes
0M-2960	Large Load Return Bus	M8 threaded holes on 2.54 mm (1 in.) and 44.5 mm (1-3/4 in.) centers	6

Table 3.7-2 Load Return Selector Table

To install either return module, loosen the 4 M5 X 8 Phillips head screws on the back of the module. The slotted screws will allow the module to be aligned precisely. Position the module in an open return position in the unit. Align the holes in the return module with the holes in the return bus and insert 2 M8 X 20 cap screws with lock washers and flat washers. Align the holes in the return module with the holes in the front of the cabinet and insert 2 M5 Phillips screws. Tighten the M8 cap screws, then the M5 screws and finally the M4 screws in the slots on the back of the module.

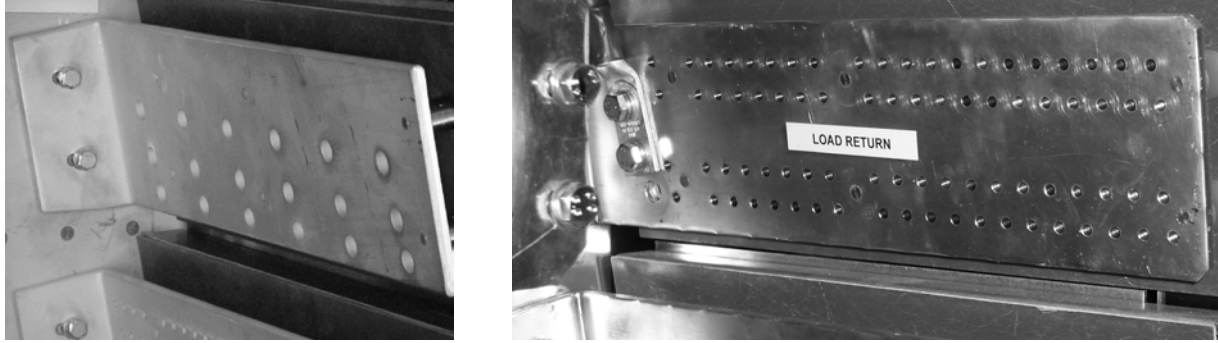

Figure 3.7-7 Large Load and Small Load Return Module

DC Load Return cable connections

The battery return module has a shunt installed and the load return modules do not. The small return has 40 pairs of M5 threaded holes on 1.59 cm (5/8 in.) centers. One set of M8 threaded holes on 2.54 mm (1 in.) and 4.45 mm (1.75 in.) centers is also provided on the small return module. The large return has 6 pairs of M8 threaded holes on 2.54 mm (1 in.) and 4.45 mm (1.75 in.) centers

3.8 Battery Installation



WARNING: Make certain that the battery polarity is correct when making connections to the Magnum XS 450 Power System. Incorrect connection could cause severe equipment damage.

Battery Tray Installation

Install Battery Shelf 1 in bottom of power system. Use M6 hardware in the lowest 2 holes on each corner post to mount the battery shelf. Battery Shelf 2 is mounted 35.5 cm (14 in.) above Battery Shelf 1.

Battery Installation

Each Battery tray is designed to hold four 12-Volt Valve Regulated Lead Acid (VRLA) type Mono-block batteries. Always follow the battery vendor's installation instructions for proper set-up of batteries. Installation of batteries should also be done with due consideration to all applicable local codes. The end user is responsible for meeting any and all local codes issues, including, but not limited to, Battery Spill Containment Systems.

Battery Disconnect Module Installation

The Battery Disconnect Module requires one open module position and is typically installed in the lowest position. Insert the module in the power system such that the holes in the module dc bus line up with the holes in the power system dc bus. Use M8 hardware to secure the buses together. Use M5 hardware to secure the front lip to the power system frame. Use M6 hardware to secure the rear of the module to the power system frame.

Connect the LVD power wiring to the power bus observing proper polarity. Connect the LVD control cable to the customer interface bus.

The alarm signal of each individual Battery Disconnect Switch is connected to the blade terminals of the switch (C and N/C). The other end of the alarm cable is connected to the J2 terminal block (User Inputs) located on the Customer Interface Board. The alarm wires of each individual Battery Disconnect Switch should be connected to the C and N/C terminals of the User Input number corresponding to the position of the battery shelf in the system. (Battery Shelf 1 Disconnect Switch Alarm to User Input 1, etc.) A 26-conductor cable to DB-25 cable is used to connect the User Input signals from the Customer Interface Board to connector PL3B on the connector backplane board.

Negative Battery Cable Connections

Connect the negative battery cables to the battery disconnect module. The battery disconnect module is located near the middle of the power system on the left side as shown in Figure 3-19 Battery Cable Connections. Each negative battery bus bar has three sets of M6 threaded holes on 1 in. (25.5mm) centers.

The Battery Disconnect Module supports two internal battery strings and up to four external battery strings in the battery cabinet. The two internal battery strings connect to the top two battery buses and can be disconnected with the two circuit breakers. A battery disconnect for each remote battery string is mounted in the top of the battery cabinet. The cable from the battery disconnect in the battery cabinet is connected to the bottom battery bus and is connected directly to the negative power plant bus.



Figure 3.8-1 Battery Cable Connections

Battery Return Module Installation

The battery return module is typically installed in the top return module position. To install the battery return module, loosen the 4 M5 X 8 Phillips head screws on the back of the unit. The slots will allow the module to be aligned precisely. Position the module in an open return position in the unit. Align the holes in the return module with the holes in the return bus and insert 2 M8 X 20 cap screws with lock washers and flat washers. Align the holes in the return module with the holes in the front of the cabinet and insert 2 M5 Phillips screws. Tighten the M8 cap screws, then the M5 screws and finally the M4 screws on the back of the module.

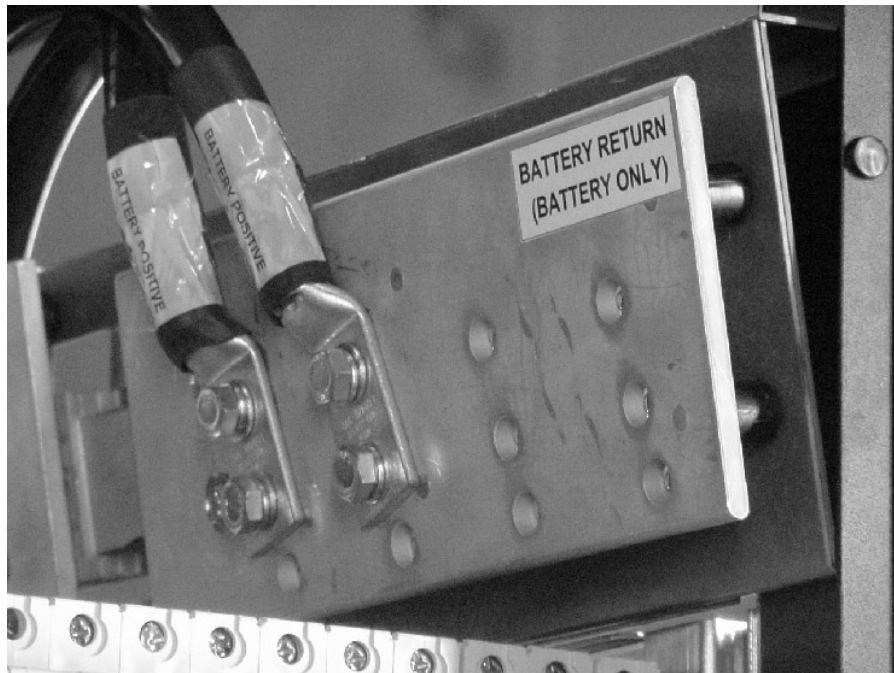

Figure 3.8-2 Battery Return Module

Positive Battery Cable Connections

The battery return module has a shunt to measure the battery current and the load return modules do not. The Battery Return with Shunt has 4 sets of M8 threaded holes on 25.4 mm (1 in.) and 4.45 mm (1-3/4 in.) centers. Connect the battery return cables from the positive side of the battery string using the M8 hardware. Also connect the battery return cables from the positive side of the remote battery strings.

Battery Temperature Probe Installation

The optional temperature probe is used to monitor the battery string temperature. To get the most representative temperature measurement, the probe should be placed in contact with a battery cell that is centrally located. The probe should be placed directly in contact with the cell (not the frame surrounding the cell). Generally, the cell cover can be used; be careful not to allow the probe body to touch the terminals. Plug the connector end of the temperature probe into PL8 of the control unit backplane card. Route the cable as required

positioning the probe on the selected battery cell. Remove the adhesive protection strip from the probe body and press the adhesive side of the probe on the battery cell cover.



Figure 3.8-3 Typical location of Battery Temperature Probe

3.9 DC System Grounding

The Positive connection (load return bus) for the power plant must be connected to the principal ground point of the building where installed. Do not connect the Battery Return Bus to the principal ground point of the building. One set of M8 threaded holes on 25.4 mm (1 in.) and 4.45 mm (1-3/4 in.) centers for connection of a two-hole lugged cable are provided on both the small and large load return modules for the connection to the building principal ground point. Any connection to the principal building ground point should be done with due consideration to all applicable local codes.

3.10 Monitoring and Relay Output Connections

Network Management Card



Figure 3.10-1 Network Management Card

Remote system monitoring is provided via the APC AP9617 Network Management Card, which is mounted on the top left hand side of the system. This card allows for the remote monitoring and control of a variety of system parameters and alarm functions. Please refer to the manuals in electronic format on the provided CD-ROM for further information on how to use the Network Management Card. Interface with the card the Network Management Card

is possible by DB-9 cable on the Console Port of the module and via RJ-45 (Ethernet) cable on the 10/100 Base-T port on the Network Management Card.

“Smart” Cable DB9 Connection

The DB9 connector on the top left hand side of the unit uses the special RS-232 cable (APC part number 940-0024C) to allow local access through a Terminal Emulation program like HyperTerminal™ or Procomm™ (**). This port is labeled as “Console”.

RJ45 Ethernet Connector

The optional management card has an RJ-45 connector to support a TCP/IP protocol over a 10BaseT Ethernet Local Area Network (LAN).

	<p>CAUTION: The Web/SNMP card has a lithium battery. This battery is not field serviceable.</p> <ul style="list-style-type: none"> • Danger of explosion if battery is replaced by an incorrect type. • Dispose of used batteries according to the manufacturer’s instructions
---	---

Relay Output Connections

There are eight relays available that provide outputs via Form “C” relay contacts. The last two of these are pre-assigned as the Minor and Major relay outputs. The Major relay is energized (N/O-COM contacts closed) during normal (non-alarm) operating conditions; all the other relays energize when an alarm condition occurs. The other six outputs are initially designated as “Relay 1” through “Relay 6”. Any of the various system alarm conditions can be assigned to any of the eight relay outputs. Wago connectors are located on the customer interface card mounted in the top right side of the unit. The relay contacts should only be used to switch resistive loads of 0.5 A or less at 60 Vdc or less. Table 3.10-1 shows the alarm output connection designations.

RELAY OUTPUT	TERMINAL DESIGNATION N/O-N/C-C	USER ALARM NOTES
RELAY #1	N/O1-N/C1-C1	_____
RELAY #2	N/O2-N/C2-C2	_____
RELAY #3	N/O3-N/C3-C3	_____
RELAY #4	N/O4-N/C4-C4	_____
RELAY #5	N/O5-N/C5-C5	_____
RELAY #6	N/O6-N/C6-C6	_____
MINOR	N/O7-N/C7-C7	_____
MAJOR	N/O8-N/C8-C8	_____

Table 3.10-1 Output Relay Connections

External Alarm Input Connections

Four external alarm inputs with assignable priority levels are available. These alarm inputs respond to external dry contact closures between normally open (N/O) and common (C) or contact openings between normally closed (N/C) and C.

External Alarm Source (non-alarm state)	Connect To Input Alarm Terminals
OPEN	NO-C
CLOSED	NC-C

Table 3.10-2 External Alarm Input Definition

Wago Connectors are located on the customer interface card mounted in the top right side of the unit. Systems are shipped with jumper wires connecting each N/C and corresponding C contact. A jumper wire should be removed only if the corresponding N/C-C contacts are going to be used.

EXTERNAL ALARM INPUT	TERMINAL DESIGNATION (N/O-N/C-C)	USER ALARM NOTES
#1	N/O1-N/C1-C1	_____
#2	N/O2-N/C2-C2	_____
#3	N/O3-N/C3-C3	_____
#4	N/O4-N/C4-C4	_____

Table 3.10-3 External Alarm Input Connections

4.1 Pre-Commissioning Inspection

Environment

1. Ensure the dc system environment is suitable for operation.
2. Ensure that there is sufficient clearance around the system for service.
3. Ensure that there is no sign of damage to the dc system.
4. Disable installed alarms before servicing the unit. This will allow the unit to be serviced without creating false alarms.

Electrical Installation

1. Ensure that the dc wiring is properly installed, sized, terminated and identified.
2. Ensure that the ac wiring is properly installed, sized, terminated and identified.
3. Ensure that the battery wiring is properly installed.
4. Ensure that the dc output over-current protection devices are adequate for the size of wiring installed.
5. Ensure that the dc Positive is bonded to the principal ground point of the building.
6. Note the resistance of the ground bond.
7. Note any currents flowing in the ground.
8. Record ambient temperature.
9. Verify that the battery polarity is correct.
10. If a battery disconnect device(s) is/are present, note the following for each device:
 - a. DC Voltage Rating.
 - b. DC Current Rating
 - c. Interrupting Current Rating

Battery Visual and Safety Inspection

1. Check the mechanical integrity of the battery framing, racking, or cabinet.
2. Check that the battery framing, racking or cabinet is adequately secured to the floor.
3. Check compliance with seismic zone requirements.
4. Check the general appearance and cleanliness of the battery.
5. Record the manufacturer, model number, and capacity of the battery string(s).
6. Record the batch number, date code, and serial number of each cell or mono-block, and any other pertinent information that is available on the battery cells.
7. Check that the cell or mono-block numbering starts at the positive battery string terminal and is correct.
8. Check that anti-oxidation compound is properly applied.
9. Visually inspect each cell for:
 - a. Cracks.
 - b. Case leaks.
 - c. Post-seal leaks.
 - d. Pressure relief valve leaks (VRLA only).
 - e. Case swelling (VRLA only).

10. Check the torque of all battery inter- cell connector in accordance with the battery manufacturer's specifications.

4.2 Commissioning

Initial Set-up

1. Remove all rectifiers.
2. Disconnect battery by removing a link in each string or opening the battery disconnects.
3. Check that battery voltage does not appear on the system bus.
4. Disconnect all loads.

AC Power Up



WARNING: The dc power plant is supplied from a nominal high voltage ac voltage source. Keep the ac input enclosure cover in place when the system is operational or energized

1. Verify that all of the circuit breaker positions are labeled to the corresponding rectifier correctly.
2. Insert all rectifiers.
3. Turn all rectifier circuit breakers on.
4. Each rectifier should have green ON LED illuminated.

NOTE: When ac power is initially applied, there is a 60-second period during which no alarms are reported.

DC Power Up:

1. Verify with a voltmeter that the dc voltage is within 0.1 Vdc of the System Voltage
2. Adjust battery float voltage to negative (-)49 Vdc.
3. Verify System Low Voltage Alarm.
4. Adjust battery float voltage to negative (-)57 Vdc.
5. Verify System High Voltage Alarm.
6. Restore the battery float voltage to negative (-) 54.00 Vdc or desired voltage.

Rectifier Test:

1. To verify that all rectifiers are reporting correctly to the controller, navigate through the menu and verify that the status for every rectifier in the system is correct.
2. Remove any rectifier and verify that you get a Minor Relay Output for rectifier 1 of n failure.
3. Remove a second rectifier and verify that you get a Major Relay Output for rectifier 2 of n failure.

Battery Power Up

1. Monitor battery current and verify that it is +/- 0.1 A.
2. Set battery maximum recharge setting by determining the entire battery string capacity and dividing by 10 hours. This setting will recharge the battery in 10 hours.
3. Enter this value in the Max Batt Rech screen.
4. Monitor the battery current while closing the battery disconnects or installing open battery links. Arcing can occur during this connection.
5. The voltage may drop if the maximum battery recharge current is exceeded.
6. The current should gradually decrease when the battery is nearing full charge.

LVD Test

1. Enable the LVDs that are installed.
2. Set the LVD trip for each LVD to negative (-)56 Vdc.
3. The LVD should have dropped out (opened). Verify by monitoring the voltage at the battery connection. Also, the minor alarm should be on.
4. Set LVD Trip back to negative (-)42 Vdc.
5. The LVD should have closed. Verify visually or by monitoring the voltage at the battery connection. The minor alarm should be off.
6. Ensure that the LVD parameters are set to desired value.

Circuit Breaker/ Fuse Test:

1. Monitor alarm screen for fuse alarms while removing and replacing NH2 style fuses in each position.
2. Verify proper voltage at fuse and circuit breaker output connections.
3. Turn on fuses and circuit breakers as desired.

User Inputs

1. Change the user input to desired output relay via the controller for any input that will be used.
2. Exercise the output relay by causing the user input to change state.
3. Verify the desired relay output LED on the controller module.

Output Relay 1:

1. Minor and Major output relays were tested in the rectifier test section.
2. Change the alarm to desired relay output via the controller for any relay output that will be used. All alarm parameters are shipped as either major or minor, but may be changed to output relay 1.
3. Program output relay 1 to desired major or minor alarm to complete programming.
4. Exercise the output relay by causing the alarm to change state.
5. Verify the desired relay output on the controller module.

Battery Temperature Compensation

1. Enable battery temperature compensation if desired.
2. Ensure that battery temperature probe is connected to the system and attached to the battery.

3. Verify that the system voltage is above the float voltage if the battery temperature is below 25 degrees C and below the float voltage if the battery temperature is above 25 degrees C.

4.3 Final Inspection:

1. Verify that the interior and exterior of the system is clean and free from debris.
2. Ensure all wires connected and bolts are properly tightened.
3. Ensure the following the User, Service, and Calibration parameters are set properly on the controller (default settings are in parenthesis):

LVD

LVD1 Trip

LVD1 Reset

Batt

Batt Disc Thr

Batt Float

Batt Max Rech

Comp Method

4. Verify that the system is functioning correctly with no alarms.
5. Be sure to leave the site as orderly and neat as possible.

5 Operation

5.1 Technical Description

The Magnum XS 450 Power System is designed to supply safe -54 Vdc primary power through the use of up to nine rectifier modules. If installed with an internal battery string, it will supply backup power as well. The controller will monitor and control all system parameters including alarms, system voltage, and system current. Modular dc output distribution supporting loads ranging from 4 amperes to 400 amperes is available.

5.2 Rectifier Management

AC Input Power

The basic component of the power system is the rectifier module, which rectifies utility ac into nominal 48 Vdc. Each rectifier module requires ac voltage in the range of 176- 293 V, 50/60 Hz. The ac input can be an individual circuit to each rectifier or can be a convenient three-phase connection. Each rectifier can have a breaker installed in the ac input area to disconnect the rectifier module.

DC Output Power

The dc outputs of all the rectifiers in the system are connected to a common bus that is rated to carry the current of the entire system. The rectifier modules will each carry a share of the entire load, independent of the controller. Individual rectifier current will be within ± 5 A of the total current divided by the number of rectifiers. The rectifiers will continue to provide dc power if the controller is removed or fails.

Rectifier alarms reporting

The rectifier has numerous sensors inside the unit that monitor fan fail, high temperature, high/low voltage, etc. These rectifier sensors trigger outputs that are monitored by a serial rectifier controller inside the rectifier. The serial rectifier controller is in constant communication with the main controller. The controller can trigger output relays in the event of a rectifier alarm. Refer to appropriate controller user manual for details.

System Voltage Control

The controller monitors and adjusts the system voltage, based on the parameters, Float Voltage, Battery Maximum Recharge Current, and Battery Temperature Compensation. In the event of controller removal or failure, the rectifiers will control the voltage at a programmed default level.

Rectifier Current

Rectifier current is measured inside each rectifier and relayed to the main controller. The controller monitors individual rectifier currents and displays total system current as a sum of rectifier currents. Refer to the specific controller user's manual for more information.

5.3 DC Distribution

DC Distribution Module

The main function of the dc distribution module is to provide a means of connecting and protecting cables that will be connected to power dc loads. The dc distribution modules also interface with the main controller to monitor the status of breakers and fuses protecting the dc loads. LVD contactors and control boards are incorporated into the various dc distribution modules.

DC Return Module

The function of the dc return modules are to provide a means of connecting return cables that will be connected to power dc loads.

5.4 Battery Management

Battery Disconnect Module

The main function of the dc distribution module is to provide a means of connecting and protecting cables that will be connected to the batteries. The battery disconnect module also interface with the main controller to monitor the status of breakers protecting the battery cables. The module also can house an LVD to disconnect the battery in the event of a deep discharge. The LVD contactors and control boards are incorporated into the battery disconnect module.

Battery Return Module

The function of the battery return module is to provide a means of connecting return cables that will be connected to batteries. Battery Current is monitored with a shunt on the battery return module.

Battery Shelves

Two internal battery shelves can be installed in the power system. (4) 12-Volt Mono-blocks can be installed in each battery tray. Only Valve Regulated Lead Acid (VRLA) type batteries are recommended for use in the battery shelves. APC offers multiple battery solutions that will fit on the battery shelves ranging in capacity from 25 AH to 170 AH. For assistance in selecting batteries appropriate to your specific application, please contact APC Customer service in your area or contact your local APC distributor.

Battery Cabinet

An external battery cabinet is available with four battery trays. A disconnect panel located in the top of the cabinet house a disconnect for each battery tray.

5.5 Customer Interface Board

Alarm Outputs (Output Relays)

There are eight alarm output relays designated Relay 1 through Relay 6, Minor, and Major, respectively. These alarms reside on the controller and are connected to the external monitoring system via the customer interface board. Refer to the specific controller user's manual for more information.

External Alarm Inputs (Input Relays)

The controller can monitor any external device that uses a switch or relay to output status information. The customer interface board handles the connections between the external inputs and the main controller.

6 Preventive Maintenance

Preventive Maintenance is typically performed on a quarterly basis.

6.1 Equipment

1. 4 Digit Voltmeter.
2. Clamp-on ampere meter.
3. Standard Insulated tools.

6.2 Inspection

Environmental Inspection

1. Ensure the dc system environment is suitable for operation.
2. Ensure that there is sufficient clearance around the system for service.
3. Ensure that there is no sign of damage to the dc system.
4. Contact monitoring personnel or disable system alarms before servicing the unit. This will allow the unit to be serviced without creating false alarms.

System Visual and Safety Inspection

	<p>WARNING: Hazardous energy levels are present on bare conductors in the -48 Vdc distribution connection area of the plant. Accidental shorting of distribution conductors can cause arcing and high currents that can cause serious burns or other physical harm. It is recommended that:</p> <ul style="list-style-type: none">• Any jewelry, rings or watches be removed while working on this equipment.• Handles of all wrenches, screwdrivers, cutters and pliers are insulated.
---	---

1. Ensure that the dc wiring is properly installed, sized, terminated and identified.
2. Ensure that the ac wiring is properly installed, sized, terminated and identified.
3. Ensure that the battery wiring is properly connected to the System.
4. Ensure that the dc output over-current protection devices are adequate for the size of wiring installed.
5. Ensure that the dc Positive is bonded to central office ground (- 48 volt system).
6. Note the resistance of the ground bond.
7. Note any currents flowing in the ground.
8. Record ambient temperature.
9. Verify that the battery polarity is correct.
10. If battery disconnect devices are present, note the following for each device:
 - a) DC Voltage Rating.
 - b) DC Current Rating
 - c) Interrupting Current Rating

Battery Visual and Safety Inspection

1. Check that the battery temperature probe is firmly attached to the battery.

2. Check the mechanical integrity of the battery framing, racking, or cabinet. Tighten where necessary.
3. If there is a battery disconnect device fitted, ensure that it is properly connected and protected.
4. Check the general appearance and cleanliness of the battery. Clean if necessary. Use only approved cleaning materials.
5. Visually inspect each cell for the following, and clean and neutralize if necessary. Document discrepancies on Site form accordingly.
 - a. Cracks.
 - b. Case leaks.
 - c. Post-seal leaks.
 - d. Pressure relief valve leaks (VRLA only).
 - e. Case swelling (VRLA only).
 - f. Terminal corrosion and connector corrosion.
6. Check the torque of all battery inter-cell connector in accordance with specifications. Re-torque if necessary (annual only).
7. Measure and record ambient temperature.

6.3 Test

System Voltage Test

1. Verify with a voltmeter directly attached to the dc bus that the system voltage is correct.
2. System voltage should also agree with the battery float voltage set up in the battery parameters section. The system may be off because of battery temperature compensation or battery recharging.

Rectifier Current Test

1. Insert voltmeter probe between I+ and common jack on front of each rectifier.
2. Record current for each rectifier using the formula – Voltage X 10 amperes/volt.
3. Rectifier current displayed under Rectifier/Info should agree with the recorded current.

Rectifier Current Share Test

Verify that the highest rectifier current and the lowest rectifier current are within 5 A.

System Current Test

Verify the System current equal to the total of the rectifier currents. System current should equal the total current of the loads as well as any battery current.

Rectifier Alarm Test

1. Verify that all of the rectifiers report RFA Alarm is off.
2. Verify that the battery voltage reading on the voltmeter is negative (-)54.00 Vdc \pm 0.02 Vdc.
3. Remove 1 rectifier and verify that you get a Minor alarm for Rect 1 of n failure on the controller and the customer remote alarm panel.
4. Remove the second rectifier and verify that you get a Major alarm for Rect 2 of n failure on the controller and the customer remote alarm panel.

5. After the fan has completely stopped spinning, insert a plastic pen or plastic screwdriver into the fan blade of one of the rectifiers and reinsert both rectifiers
6. Verify that you get the fan fail alarm on controller and the customer remote alarm panel.
7. Remove the fan fail device.

System Temperature Test

Verify that the system temperature is correct.

Battery Current Test

1. Measure the battery current with a clamp-on meter.
2. Verify that the battery current is below 5 A.
3. Verify that the displayed battery current is within ± 5 A.
4. Determine the total battery capacity at the site:
Cells connected in series make up a string, and the capacity is determined by the capacity of a single cell. Add ampere/hour capacity for all strings connected in parallel.
5. Determine the Max. Batt. Recharge rate:
Divide Total battery capacity by 20 hours and enter it in the appropriate box on the Site Form.
6. Verify that the Max. Batt. Recharge rate is set to the calculated value.
7. Remove ac power to the rectifiers purposely causing the battery discharge alarm to come on.
8. Verify that the System Current is 0 ± 5 A.
9. Verify that the battery current is within 5 % of the system current recorded previously.
10. Verify that the Battery Discharge Alarm is on.
11. Restore ac power to the rectifiers.

Battery Temperature Test

If the battery temperature probe is used in this system, verify that the battery temperature is correct.

LVD Test

1. Ensure that the LVD parameters are set to proper value.
2. Set the LVD Trip to -56.00 Vdc.
3. The LVD should have dropped out (opened). Verify it by monitoring the voltage at the battery connection.
4. Verify that the LVD Open Alarm is registered on the controller and at the customer remote alarm panel.
5. Reset the LVD Trip to negative (-) 42.00 Vdc.
6. Verify that the LVD Open Alarm has been removed.

Battery Preventive Maintenance Procedure

The purpose of the preventive maintenance is to ensure that the battery is in good, working condition. The observations, measurements, and tests performed are designed to determine the “state of health” of the battery. It will also allow for the prediction of future performance and preempt possible failure.

1. Measure the float charge voltage.
 - a. At the power bay bus.
 - b. At the battery.
 - c. Reset voltage if necessary.
2. Measure the float current on each battery cable. If it is fluctuating, measure maximum and minimum.
3. Measure the ac ripple voltage at the battery.
4. Measure and record the float voltage of each cell or monoblock.
5. Perform a load test on each cell or monoblock and measure the internal cell resistance and inter-cell resistance of each cell or monoblock.
6. Ensure that all protective covers are replaced and that the battery is electrically non-hazardous to personnel that could be working in the vicinity

6.4 Final Inspection:

1. Verify that the interior and exterior of the system is clean and free from debris.
2. Ensure all wires connected and bolts are properly tightened.
3. Ensure the following the User, Service, and Calibration parameters are set properly on the controller (default settings are in parenthesis):

LVD (Param)

LVD1 Trip (-42.00 V)

LVD1 Reset (-48.00 V)

Batt (Set-alm)

Batt Disc Thr (10 A)

Batt (Param)

Batt Float (-54.00 V)

Batt Max Rech (10 A)

Batt (Comp)

Comp Method (ON).

4. Verify on the status menu that the system is functioning correctly with no alarms.
5. Be sure to leave the site as orderly and neat as possible.

7 Specifications

The overall system specifications can vary, depending upon the number of rectifier modules. Note that some specification items are provided on a “per rectifier” basis and must be combined or totaled for a give system configuration.

7.1 AC Input DCPM28HN54SH0 Rectifier

Nominal Input Voltage	220, 230, 240, 277 Vac
Rated Input Voltage Range	216- 277 Vac
Operational Input Voltage Range	176- 293 Vac (De-rated output from 176- 195 Vac)
AC Frequency Range	45 – 65 Hz
Apparent Power Factor	99% Typical, 98% Minimum
Maximum Input Current (per Rectifier)	13.9 A @ 230 Vac

7.2 Mechanical

Dimensions (Height X Width X Depth)	2000 mm (78.7 in) x 600 mm (23.6 in) X 600 mm (23.6 in) (Not including doors)	
Weight	Housing	250 kg (550 lb)
	Rectifier (each)	5 kg (11 lb)
Color	Raven Black	
Mounting	Floor Mounting	

7.3 Environmental

Ambient Temperature	(Operating)	-40 °C to +55 °C (+65 °C with reduced power output)
	(Storage)	-45 °C to +85 °C
Relative Humidity	(Operating)	0 – 85% (non-condensing)
	(Storage)	0 – 95% (non-condensing)
Altitude	(Operating)	3000 m (9840 ft)
	(Storage)	10000 m (39370 ft)

7.4 Compliance

Safety	IEC 60950, 3 rd Edition CE Marked to Low Voltage Directive (EN60950, 3 rd Edition)
EMC	FCC Part 15 Class A EN55022 Class A, EN55024 EN61000-3-2, EN61000-3-3

8 APC Worldwide Customer Support

Customer Support for this or any other APC product is available at no charge. You can contact APC Customer Support in any of the following ways:

- Use an APC web page to find answers to frequently asked questions (FAQs), to access documents in the APC Knowledge Base, and to submit customer support requests.
 - <http://www.apc.com>
Connect by links to APC web pages for specific countries and regions, each of which provides customer support information.
 - <http://www.apc.com/support/>
Submit customer support requests.
 - <http://www.apc.com/support/contact>
For e-mail addresses and local, country-specific, customer support telephone numbers worldwide.
- Contact Local or regional APC Customer Support by telephone.

US and Canada	1-(800) 800-4272	Netherlands	0800 0232509
China	800 810 0160	Norway	800 10436
Austria	0800 999670	Poland	0801 345917
Belgium	0800 40677	Portugal	800 853182
Czech Republic	800 102063	Russia	8800 2002722
Denmark	80 884953	Slovak Republic	0800 172063
Finland	0800 115308	South Africa	086 1 272877
France	0805 110053	Spain	800 853182
Greece	00800 125924	Sweden	0200 895283
Hungary	0640 200262	Switzerland	0800 111469
Ireland	1890 272877	Turkey	800 2612135
Israel	1800 9452206	United Kingdom	0800 2799254
Italy	800 22091	Ukraine	8800 5027220
Luxembourg	800 22091	Worldwide	(+1) 1 401 789-5735

- Contact the APC representative or other distributor from whom you purchased your APC hardware device or APC software application for information on how to obtain local customer support.

9 Limited Product Warranty

The limited warranty provided by American Power Conversion Corporation ("APC") in this Statement of Limited Factory Warranty applies only to Products Buyer purchases for your commercial or industrial use in the ordinary course of Buyer's business.

APC PRODUCTS COVERED ("Product or Products"):

Magnum XS 450 Power System

Terms of Warranty:

APC warrants that the Product shall be free from defects in materials and workmanship, for a period of two (2) years from the date of shipment.

Warranty Procedure

If initial physical inspection results in identification of a material or workmanship flaw(s) that could impair Product performance as defined by APC 's electrical and physical specification in effect at the time of shipment, and if this flaw(s) is not due to transportation damage or installation abuse, contact APC or call the 24-hour emergency number, (800) 800 4APC, to request assistance.

You will be provided either a) an RMA number with instructions for return of the equipment or component(s) to the APC factory service center, FOB destination, freight pre-paid, for examination, or b) for non-returnable systems and equipment, notice to wait until an APC authorized service representative arrives at the site to inspect the equipment. Repaired or advance replacement modules or circuit components will normally be available within 24 to 48 hours of receipt of equipment or RMA.

Warranty Obligations - Repair or Replacement

If, during the warranty period, the Product is found to be physically or electrically faulty due to defective materials or workmanship, the defective Product(s) or component(s) will be repaired or replaced at the sole option of APC. If the procedure outlined above for contacting APC immediately after identifying a material or workmanship flaw(s) that could impair Product performance has been properly followed, such repair or replacement of Product(s) or component(s) shall include all charges for replacement materials or repair labor. Costs incurred for replacement installation including, but not limited to, installation equipment, travel expenses of an APC representative(s), and costs of installation material transportation expenses are not included as a part of this warranty. Any replacement components or materials furnished under this warranty may be new or factory remanufactured. THIS WARRANTY DOES NOT COVER CONSUMABLES OR PREVENTATIVE MAINTENANCE ITEMS. REPAIR OR REPLACEMENT OF A DEFECTIVE PRODUCT OR COMPONENT THEREOF DOES NOT EXTEND THE ORIGINAL WARRANTY PERIOD.

Exclusions and Limitations

This Warranty is extended to the first person, firm, association or corporation for whom the APC Product specified herein has been bought. This Warranty is not transferable or assignable without the prior written permission of APC.

This limited warranty does not cover damage due to external causes, including accident, abuse, misuse, servicing not authorized by APC, usage not in accordance with Product instructions, failure to perform preventative maintenance, and problems cause by use of parts and components not supplied by APC. This limited warranty does not apply to Products from which the serial numbers have been removed, or to conditions resulting from improper use, accidents, external causes, including installation, relocation of hardware, service or modifications not performed by APC or its authorized service providers, or operation outside the environmental parameters specified for the Product. APC does not warrant that the operation of any Product will be uninterrupted or error free. Warranty service may not be performed if APC or other suppliers reasonably believe conditions at the Buyer's site represent a safety or health risk.

THERE ARE NO WARRANTIES, EXPRESS OR IMPLIED, BY OPERATION OF LAW OR OTHERWISE, OF PRODUCTS SOLD, SERVICED OR FURNISHED UNDER THIS AGREEMENT OR IN CONNECTION HERewith. APC DISCLAIMS ALL IMPLIED WARRANTIES OF MERCHANTABILITY, SATISFACTION AND FITNESS FOR A PARTICULAR PURPOSE. APC'S EXPRESS WARRANTIES WILL NOT BE ENLARGED, DIMINISHED, OR AFFECTED BY AND NO OBLIGATION OR LIABILITY WILL ARISE OUT OF, APC'S RENDERING OF TECHNICAL OR OTHER ADVICE OR SERVICE IN CONNECTION WITH THE PRODUCTS. THE FOREGOING WARRANTIES AND REMEDIES ARE EXCLUSIVE AND IN LIEU OF ALL OTHER WARRANTIES AND REMEDIES. THE WARRANTIES SET FORTH ABOVE, CONSTITUTE APC'S SOLE LIABILITY AND YOUR EXCLUSIVE REMEDY FOR ANY BREACH OF SUCH WARRANTIES. APC'S WARRANTIES RUN ONLY TO YOU AND ARE NOT EXTENDED TO ANY THIRD PARTIES. IN NO EVENT SHALL APC, ITS OFFICERS, DIRECTORS, AFFILIATES OR EMPLOYEES BE LIABLE FOR ANY FORM OF INDIRECT, SPECIAL, CONSEQUENTIAL OR PUNITIVE DAMAGES, ARISING OUT OF THE USE, SERVICE OR INSTALLATION, OF THE PRODUCTS, WHETHER SUCH DAMAGES ARISE IN CONTRACT OR TORT, IRRESPECTIVE OF FAULT, NEGLIGENCE OR STRICT LIABILITY OR WHETHER APC HAS BEEN ADVISED IN ADVANCE OF THE POSSIBILITY OF SUCH DAMAGES.