



# Airless Paint Sprayer

Item 68001

## ⚠ WARNING

Read this material before using this product.  
Failure to do so can result in serious injury.  
**SAVE THIS MANUAL.**

## NOTICE

### **CLEAN IMMEDIATELY**

Clean the Sprayer **IMMEDIATELY** after use.  
Delayed or inadequate cleaning will permanently clog the Sprayer.

**Warranty void if sprayer is not properly cleaned immediately after every use.**

See "Cleaning" on pages 16-17.



When unpacking, make sure that the product is intact and undamaged.  
If any parts are missing or broken, please call 1-800-444-3353 as soon as possible.

Visit our website at: <http://www.harborfreight.com>  
Email our technical support at: [tech@harborfreight.com](mailto:tech@harborfreight.com)

## NOTICE

Clean the Sprayer IMMEDIATELY after use. Delayed or inadequate cleaning will permanently clog the Spray Gun. Warranty void if sprayer is not properly cleaned immediately after every use.

## Save This Manual

Keep this manual for the safety warnings and precautions, assembly, operating, inspection, maintenance and cleaning procedures. Write the product's serial number on the front page of the user's manual (or month and year of purchase if product has no number). Keep this manual and the receipt in a safe and dry place for future reference.

## Important Safety Information

In this manual, on the labeling, and all other information provided with this product:



This is the safety alert symbol. It is used to alert you to potential personal injury hazards. Obey all safety messages that follow this symbol to avoid possible injury or death.

### **⚠ DANGER**

DANGER indicates a hazardous situation which, if not avoided, will result in death or serious injury.

### **⚠ WARNING**

WARNING indicates a hazardous situation which, if not avoided, could result in death or serious injury.

### **⚠ CAUTION**

CAUTION, used with the safety alert symbol, indicates a hazardous situation which, if not avoided, could result in minor or moderate injury.

### **NOTICE**

NOTICE is used to address practices not related to personal injury.

### **CAUTION**

CAUTION, without the safety alert symbol, is used to address practices not related to personal injury.

## Symbol Definitions

Symbol	Property or statement
<b>PSI</b>	Pounds per square inch of pressure
<b>NPT</b>	National pipe thread, tapered
<b>NPS</b>	National pipe thread, straight
	WARNING marking concerning Risk of Eye Injury. Wear ANSI-approved eye protection.
	WARNING marking concerning Risk of Hearing Loss. Wear hearing protection.
	WARNING marking concerning Risk of Respiratory Injury. Wear NIOSH-approved respirator.
	WARNING marking concerning Risk of Explosion.
	WARNING marking concerning Risk of Injection Injury. Do not direct spray at hands or body. Have injection injury treated immediately.
	WARNING marking concerning Risk of Fire. Ground any metal bucket used with sprayer.



**WARNING! Read all instructions.**

**Failure to follow all instructions listed below may result in fire, serious injury and/or DEATH.**

The warnings and precautions discussed in this manual cannot cover all possible conditions and situations that may occur. It must be understood by the operator that common sense and caution are factors which cannot be built into this product, but must be supplied by the operator.

**SAVE THESE INSTRUCTIONS**

## NOTICE

Clean the Sprayer IMMEDIATELY after use. Delayed or inadequate cleaning will permanently clog the Spray Gun. Warranty void if sprayer is not properly cleaned immediately after every use.

### Safety Warnings



**WARNING** Read all safety warnings and instructions. Failure to follow the warnings and instructions may result in serious injury. Save all warnings and instructions for future reference.

1. **Work area safety**
  - a. **Keep work area clean and well lit.**  
*Cluttered or dark areas invite accidents*
  - b. **Operate only in a well-ventilated area.**  
*Paint thinners and solvents may be harmful if inhaled.*
  - c. **Do not operate the sprayer in explosive atmospheres, such as in the presence of flammable liquids, gases, or dust.** *The sprayer is able to create sparks resulting in the ignition of the dust or fumes.*
  - d. **Keep children and bystanders away while operating a sprayer.**  
*Distractions can cause you to lose control.*
2. **Electrical safety**
  - a. **Sprayer plugs must match the outlet. Never modify the plug in any way. Do not use any adapter plugs with grounded sprayers.**  
*Unmodified plugs and matching outlets will reduce risk of electric shock.*
  - b. **Avoid body contact with grounded surfaces such as pipes, radiators, ranges and refrigerators.** *There is an increased risk of electric shock if your body is grounded.*
  - c. **Do not expose sprayers to rain or wet conditions.** *Water entering a sprayer will increase the risk of electric shock.*
  - d. **Do not abuse the cord. Never use the cord for carrying, pulling or unplugging the sprayer. Keep cord away from heat, oil, sharp edges or moving parts.** *Damaged or entangled cords increase the risk of electric shock.*
  - e. **When operating a sprayer outdoors, use an extension cord suitable for outdoor use.**  
*Use of a cord suitable for outdoor use reduces the risk of electric shock.*
  - f. **If operating a sprayer in a damp location is unavoidable, use a Ground Fault Circuit Interrupter (GFCI) protected supply.**  
*Use of a GFCI reduces the risk of electric shock.*
3. **Personal safety**
  - a. **Stay alert. Watch what you are doing and use common sense when operating the sprayer. Do not use the sprayer while tired or under the influence of drugs, alcohol, or medication.** *A moment of inattention while operating the sprayer increases the risk of injury to persons.*
  - b. **Dress properly. Do not wear loose clothing or jewelry. Contain long hair. Keep hair, clothing, and gloves away from moving parts.** *Loose clothes, jewelry, or long hair increases the risk of injury to persons as a result of being caught in moving parts.*
  - c. **Avoid unintentional starting. Be sure the trigger is off before connecting to the power supply. Do not carry the sprayer with your finger on the trigger or connect the sprayer to the power supply with the trigger on.**
  - d. **Do not overreach. Keep proper footing and balance at all times.** *Proper footing and balance enables better control of the sprayer in unexpected situations.*
  - e. **Use safety equipment.**  
*Wear ANSI-approved safety goggles, a NIOSH-approved respirator, heavy-duty work gloves and non-skid safety shoes when priming, painting, cleaning, or servicing.*
4. **Sprayer use and care**
  - a. **Do not force the sprayer. Use the correct sprayer for your application.**  
*The correct sprayer will do the job better and safer at the rate for which it was designed.*
  - b. **Do not use the sprayer if the switch does not turn it on and off.** *Any sprayer that cannot be controlled with the switch is dangerous and must be repaired.*
  - c. **Disconnect the plug from the power source before making any adjustments, changing accessories, or storing sprayers.** *Such preventive safety measures reduce the risk of starting the sprayer accidentally.*
  - d. **Store idle sprayers out of the reach of children and do not allow persons unfamiliar with the sprayer or these instructions to operate the sprayer.** *Sprayers are dangerous in the hands of untrained users.*
  - e. **Maintain the sprayer. Check for misalignment or binding of moving parts, breakage of parts and any other condition that may affect the**



## NOTICE

Clean the Sprayer IMMEDIATELY after use. Delayed or inadequate cleaning will permanently clog the Spray Gun. Warranty void if sprayer is not properly cleaned immediately after every use.

sprayer's operation. If damaged, have the sprayer repaired before use. *Many accidents are caused by poorly maintained sprayers.*

- f. Use the sprayer and accessories in accordance with these instructions, taking into account the working conditions and the work to be performed. *Use of the sprayer for operations different from those intended could result in a hazardous situation.*

### 5. Service

- a. Have your sprayer serviced by a qualified repair person using only identical replacement parts. *This will ensure that the safety of the sprayer is maintained.*

## Paint Sprayer Safety Warnings

- **INJECTION HAZARD!**  
Although this paint gun is airless, it still puts out paint at a very high pressure. Through improper use, paint can be injected through a person's skin, leading to serious injury, possibly amputation. If paint is accidentally injected into someone's skin, contact a doctor immediately. Do not treat an injection injury as a simple cut. Injection can lead to amputation and requires immediate surgical treatment.
- Do not point your sprayer at anyone, including yourself. Do not place your hand in front of Spray Gun's nozzle or attempt to deflect paint spray with your hand during use.**  
Gloves and clothing don't offer adequate protection from toxic paints, sealers, water-proofers, or stains.
- Do not come into contact with a fluid stream created by a leak in the paint hose.**
- Engage the Spray Gun's trigger lock when not spraying.**
- Do not leave Paint Sprayer pressurized while unattended.**
- Do not clean Spray Gun tip while it is still connected to paint hose.**
- Keep the trigger and the electrical cord plug clean and paint-free.**
- Do not run Paint Sprayer while empty.**  
Damage to the unit may occur.
- Do not use Paint Sprayer to spray asbestos, metallic paints, glazes, red lead, cement, ground chalk, abrasive grainy paints containing lime, or bleach.**  
These will damage the spray gun and void the warranty.
- Do not spray flammable materials in vicinity of open flame or near ignition sources.** Motors, electrical equipment, and controls can cause electrical arcs that will ignite a flammable gas or vapor. Do not store flammable liquids or gases in vicinity of this unit.
- Keep fire-extinguishing equipment present and in good-working order.
- Keep pump away from spray area to avoid contact with solvents and paint fumes.
- Use Paint Sprayer with water-based or mineral spirit-type materials only.
- Do NOT use bleach, low-flash naphthalene, acetone alcohol or toluene when cleaning Paint Sprayer equipment.
- Do NOT use solvents with flash points less than 70° F (21° C) to clean equipment. These may cause an explosion. Examples of acceptable cleaning solvents are water, mineral spirits and lacquer thinner. Note that some of these solvents may be inappropriate for certain kinds of paint; follow the paint supplier's recommendations. Contact Harbor Freight Tools to request a Material Safety Data Sheet (MSDS).
- Follow the material and solvent manufacturer's safety precautions and warnings.
- Keep paint hose away from sharp objects. Bursting hoses may cause injury. Examine hoses regularly and replace if damaged.
- When flushing Paint Sprayer system, use lowest possible pressure setting.
- All hoses and spray gun accessories used with Paint Sprayer must be pressure rated at or above 3000 PSI.
- The Paint Sprayer must be plugged into an outlet that is grounded in accordance with all local codes and ordinances.
- Use caution while spraying on windy days.
- Do not use Paint Sprayer without the Spray Gun's nozzle guard in place.
- Paint Sprayer's housing may become hot during use. Do not touch housing until it has completely cooled.

## NOTICE

**Clean the Sprayer IMMEDIATELY after use. Delayed or inadequate cleaning will permanently clog the Spray Gun. Warranty void if sprayer is not properly cleaned immediately after every use.**

24. Remove Spray Tip or turn to cleaning position BEFORE cleaning or flushing Paint Sprayer system.

25. Do not use pliers to tighten or loosen high pressure connections.

26.  **Sparks from improper grounding can ignite fumes!** Follow all local regulations regarding the use of fluid supply containers and solvent pails used with flushing the Paint Sprayer.

Use only conductive metal pails placed on a grounded (concrete) surface. Do not place pails on nonconductive surfaces (such as cardboard or paper). Ground all metal pails by clamping one end of a ground wire to the pail and the other end to a grounded structure (such as a nearby pipe). Maintain grounding, even when flushing or relieving pressure from Paint Sprayer into metal pail. The force of the spray can knock a metal pail over, so hold down the metal pail and keep the metal part of the spray gun set against the grounded metal pail when pressing the spray gun trigger.

27. Maintain labels and nameplates on the sprayer. These carry important safety information. If unreadable or missing, contact Harbor Freight Tools for a replacement.

28. Avoid unintentional starting. Prepare to begin work before turning on the sprayer.

29. This product is not a toy. Keep it out of reach of children.

30. People with pacemakers should consult their physician(s) before use. Electromagnetic fields in close proximity to heart pacemaker could cause pacemaker interference or pacemaker failure.

31. **WARNING:** Some dust created by power sanding, sawing, grinding, drilling, and other construction activities, contains chemicals known [to the State of California] to cause cancer, birth defects or other reproductive harm. Some examples of these chemicals are:

- Lead from lead-based paints
- Crystalline silica from bricks and cement or other masonry products
- Arsenic and chromium from chemically treated lumber

Your risk from these exposures varies, depending on how often you do this type of work. To reduce your exposure to these chemicals: work in a well ventilated area, and work with approved safety equipment, such as those dust masks that are specially designed to filter out microscopic particles. (California Health & Safety Code § 25249.5, *et seq.*)

32. **WARNING:** Handling the cord on this product will expose you to lead, a chemical known to the State of California to cause cancer, and birth defects or other reproductive harm. Wash hands after handling. (California Health & Safety Code § 25249.5, *et seq.*)



**SAVE THESE INSTRUCTIONS.**

## NOTICE

Clean the Sprayer **IMMEDIATELY** after use. Delayed or inadequate cleaning will permanently clog the Spray Gun. Warranty void if sprayer is not properly cleaned immediately after every use.

### Grounding

#### ⚠ WARNING



**TO PREVENT ELECTRIC SHOCK AND DEATH FROM INCORRECT GROUNDING WIRE CONNECTION:**

Check with a qualified electrician if you are in doubt as to whether the outlet is properly grounded. Do not modify the power cord plug provided with the sprayer. Never remove the grounding prong from the plug. Do not use the sprayer if the power cord or plug is damaged. If damaged, have it repaired by a service facility before use. If the plug will not fit the outlet, have a proper outlet installed by a qualified electrician.

### Grounded Sprayers: Sprayers With Three Prong Plugs

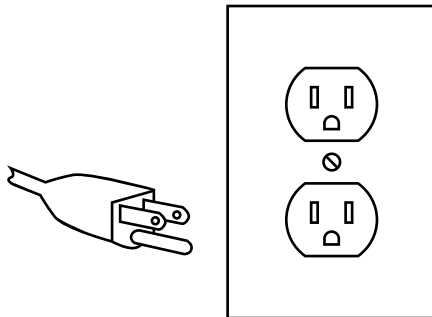

**3-Prong Plug and Outlet**

1. Sprayers marked with "Grounding Required" have a three wire cord and three prong grounding plug. The plug must be connected to a properly grounded outlet. If the sprayer should electrically malfunction or break down, grounding provides a low resistance path to carry electricity away from the user, reducing the risk of electric shock. (See 3-Prong Plug and Outlet.)
2. The grounding prong in the plug is connected through the green wire inside the cord to the grounding system in the sprayer. The green wire in the cord must be the only wire connected to the sprayer's grounding system and must never be attached to an electrically "live" terminal. (See 3-Prong Plug and Outlet.)
3. The sprayer must be plugged into an appropriate outlet, properly installed and grounded in accordance with all codes and ordinances. The plug and outlet should look like those in the preceding illustration. (See 3-Prong Plug and Outlet.)

### Extension Cords

1. **Grounded** sprayers require a three wire extension cord. **Double Insulated** sprayers can use either a two or three wire extension cord.
2. As the distance from the supply outlet increases, you must use a heavier gauge extension cord. Using extension cords with inadequately sized wire causes a serious drop in voltage, resulting in loss of power and possible sprayer damage. (See Table A.)
3. The smaller the gauge number of the wire, the greater the capacity of the cord. For example, a 14 gauge cord can carry a higher current than a 16 gauge cord. (See Table A.)
4. When using more than one extension cord to make up the total length, make sure each cord contains at least the minimum wire size required. (See Table A.)
5. If you are using one extension cord for more than one sprayer, add the nameplate amperes and use the sum to determine the required minimum cord size. (See Table A.)
6. If you are using an extension cord outdoors, make sure it is marked with the suffix "W-A" ("W" in Canada) to indicate it is acceptable for outdoor use.
7. Make sure the extension cord is properly wired and in good electrical condition. Always replace a damaged extension cord or have it repaired by a qualified electrician before using it.
8. Protect the extension cords from sharp objects, excessive heat, and damp or wet areas.

#### RECOMMENDED MINIMUM WIRE GAUGE FOR EXTENSION CORDS\* (120/240 VOLT)

NAMEPLATE AMPERES (at full load)	EXTENSION CORD LENGTH				
	25'	50'	75'	100'	150'
0 – 2.0	18	18	18	18	16
2.1 – 3.4	18	18	18	16	14
3.5 – 5.0	18	18	16	14	12
5.1 – 7.0	18	16	14	12	12
7.1 – 12.0	18	14	12	10	-
12.1 – 16.0	14	12	10	-	-
16.1 – 20.0	12	10	-	-	-





**TABLE A**

\* Based on limiting the line voltage drop to five volts at 150% of the rated amperes.

## NOTICE

Clean the Sprayer IMMEDIATELY after use. Delayed or inadequate cleaning will permanently clog the Spray Gun. Warranty void if sprayer is not properly cleaned immediately after every use.

### Symbology

	Double Insulated
	Canadian Standards Association
	Underwriters Laboratories, Inc.
	Volts Alternating Current
	Amperes
$n_0$ xxxx/min.	No Load Revolutions per Minute (RPM)

# NOTICE

Clean the Sprayer IMMEDIATELY after use. Delayed or inadequate cleaning will permanently clog the Spray Gun. Warranty void if sprayer is not properly cleaned immediately after every use.

## Before You Begin

Familiarize yourself with the Paint Sprayer and its functions.

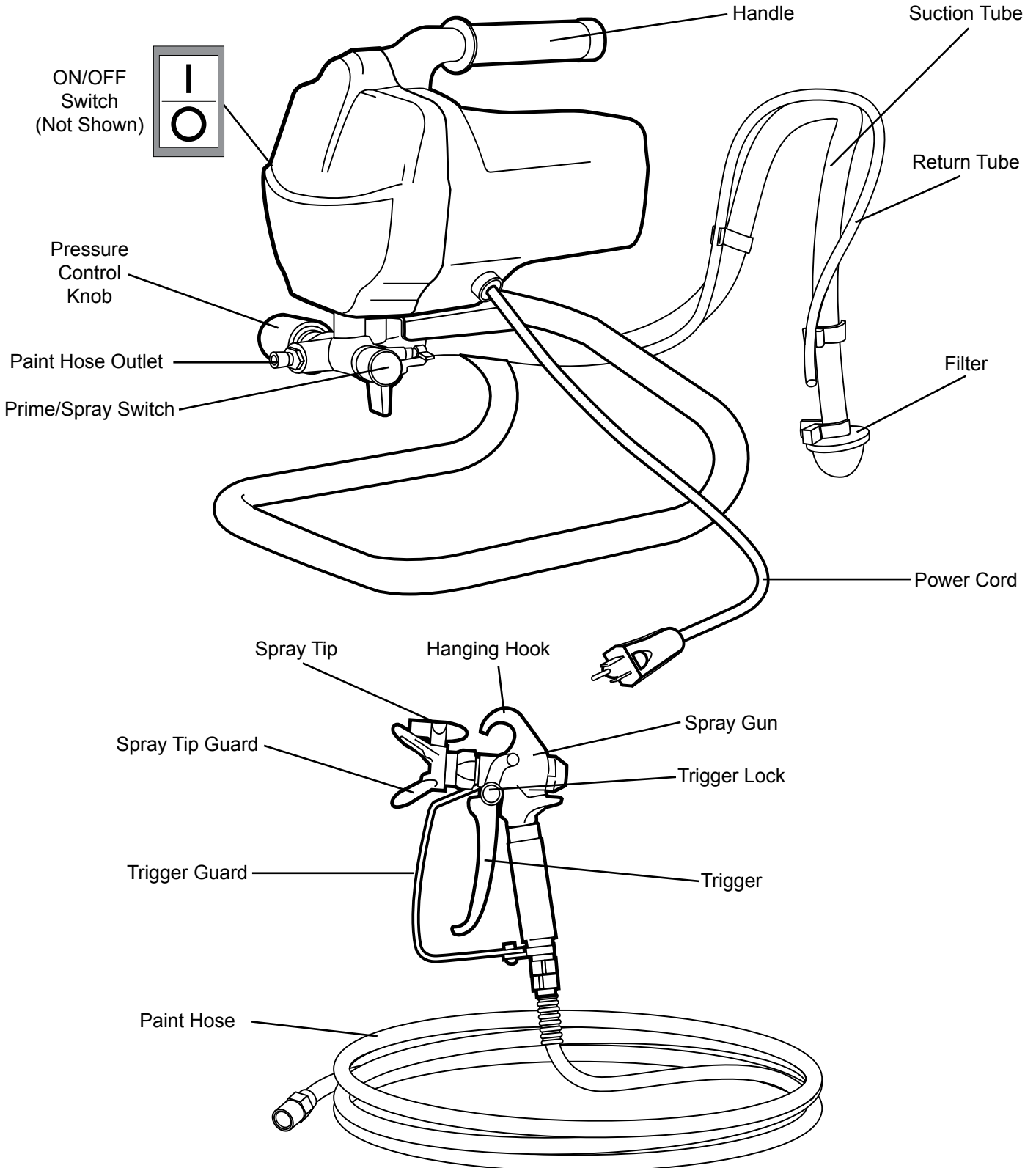



# NOTICE

Clean the Sprayer IMMEDIATELY after use. Delayed or inadequate cleaning will permanently clog the Spray Gun. Warranty void if sprayer is not properly cleaned immediately after every use.

## Prime/Spray Switch

This switch toggles the unit between priming mode and spraying mode.

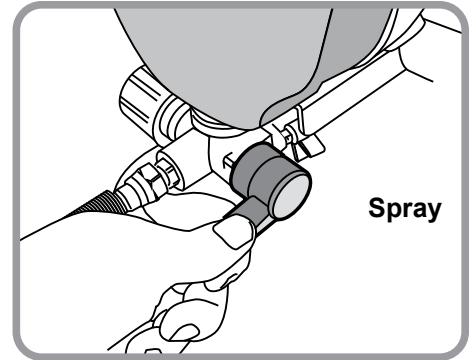
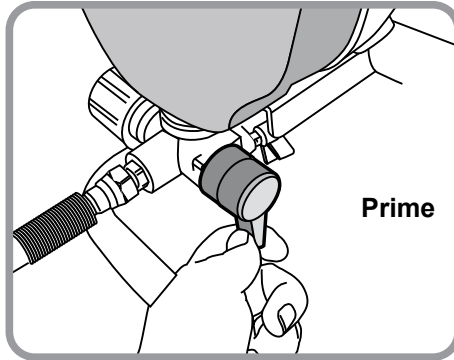

## Trigger Lock

When engaged, this mechanism prevents the trigger from being pulled accidentally such as if the gun is dropped.

Lock whenever not in use.

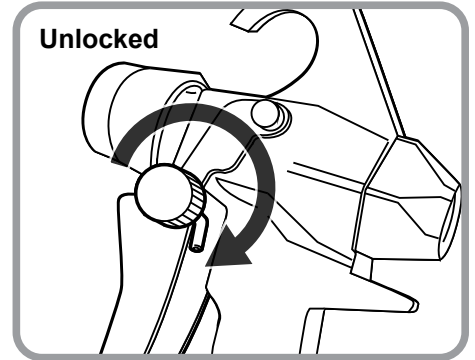
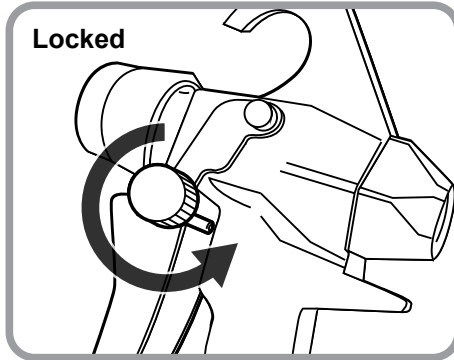

## Nozzle

The nozzle is reversible and removable to make cleaning and unlogging easier.

Turn to Spray (▶) position to use the spray gun.

Turn to Clean (Eject) position to clean the nozzle.

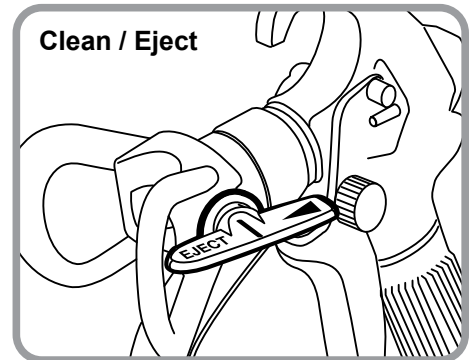
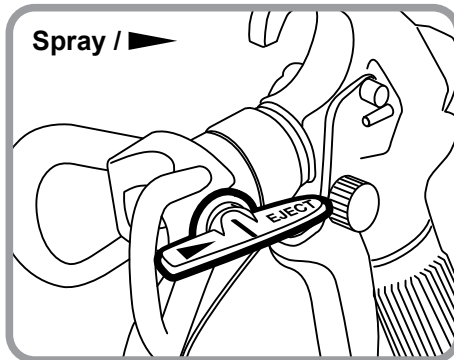

## Pressure Control Knob

The Pressure Control Knob can be adjusted for High Pressure Spraying, Low Pressure Spraying, Priming/Cleaning, or Rolling. Align the Pressure Control Knob with indicator on the Sprayer Housing to set the function.

Low Pressure Spray

Rolling



High Pressure Spray

Prime/Clean

## NOTICE

Clean the Sprayer IMMEDIATELY after use. Delayed or inadequate cleaning will permanently clog the Spray Gun. Warranty void if sprayer is not properly cleaned immediately after every use.

### Setup

**Note:** Remove or cover objects that you want to protect from overspray (paint mist).

1. Attach Paint Hose to Paint Hose Outlet and tighten with wrench.

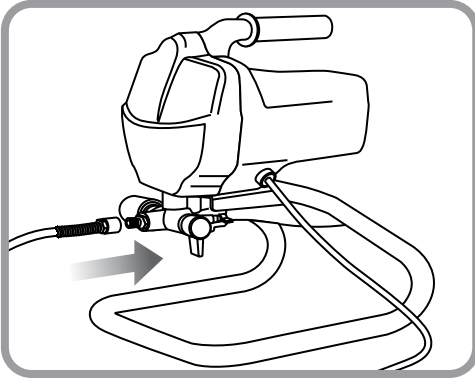

2. Attach Paint Hose to Paint Gun and tighten with two wrenches.

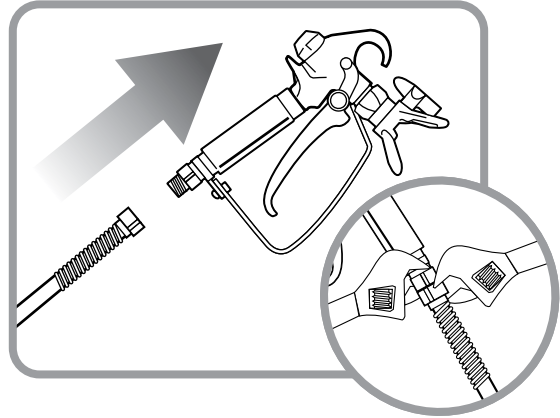

3. Turn Pressure Control Knob to Low Pressure Spray setting.

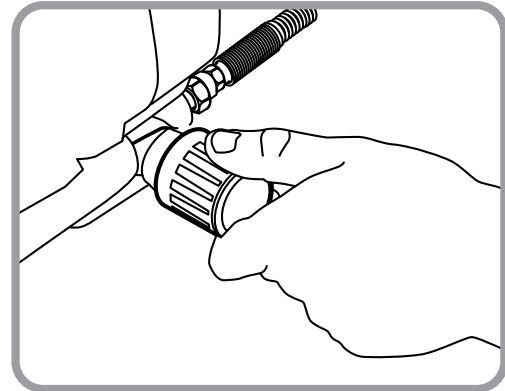

## NOTICE

Clean the Sprayer IMMEDIATELY after use. Delayed or inadequate cleaning will permanently clog the Spray Gun. Warranty void if sprayer is not properly cleaned immediately after every use.

### To Relieve Sprayer Pressure

1. Turn Power Switch off and unplug unit from outlet.

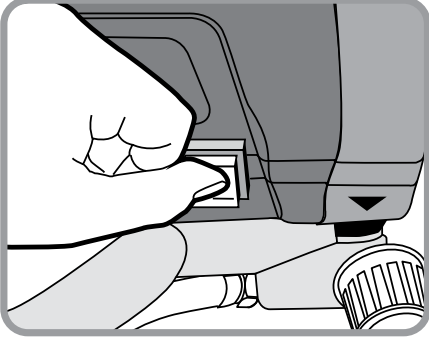

2. Switch Prime/Spray switch to Prime mode.

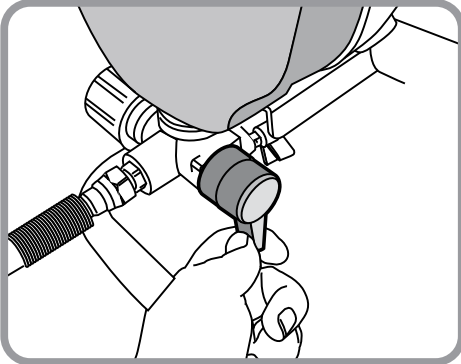

3. Point gun into paint pail and activate Sprayer Trigger to relieve pressure.

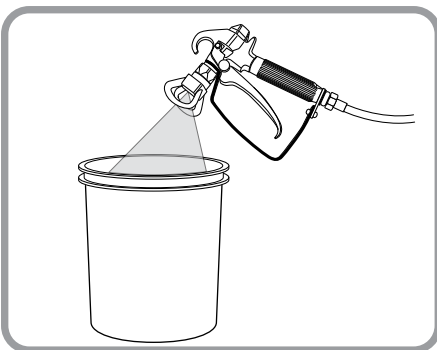

4. Turn Trigger Lock Knob to Locking position.

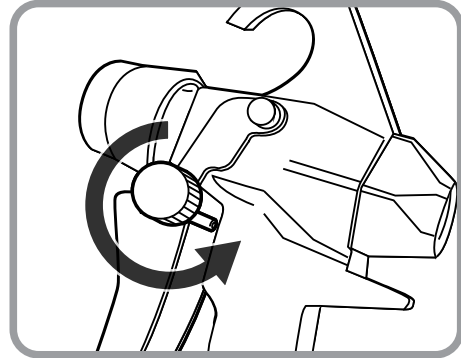

5. Switch Prime/Spray switch to Prime mode.

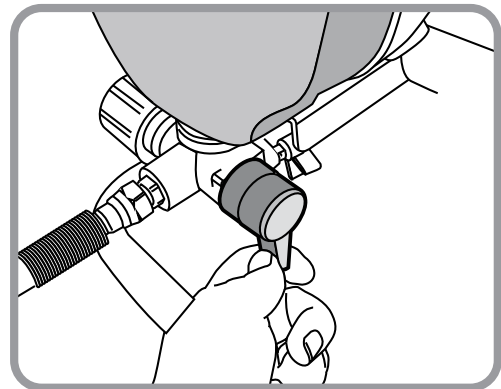

## NOTICE

Clean the Sprayer IMMEDIATELY after use. Delayed or inadequate cleaning will permanently clog the Spray Gun. Warranty void if sprayer is not properly cleaned immediately after every use.

### Priming Spray Gun

This procedure is used for first time operation and also to flush storage fluids out of the Sprayer.

#### Priming Water-Based vs. Oil-Based Paints

##### Oil-based Paint:

Flush with mineral spirits followed by warm clean water.

##### **WARNING! TO PREVENT FIRE:**

When using mineral spirits, ground gun by holding it against a metal container while flushing.

##### Water-based (Latex) Paint:

Flush with warm clean water.

#### Priming and Startup Steps

1. Separate smaller Return Tube from Suction Tube.

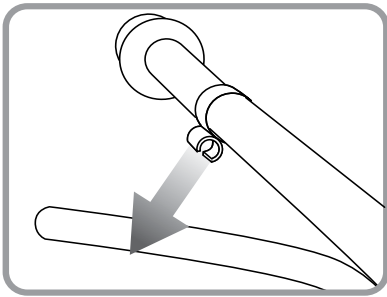

2. Place Return Tube in waste bucket.

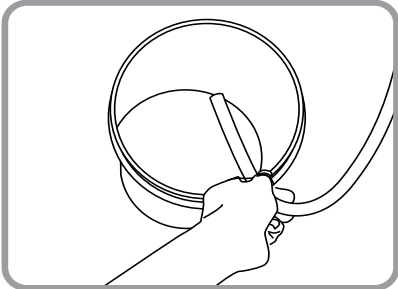

3. Submerge Suction Tube in water or flushing solvent.

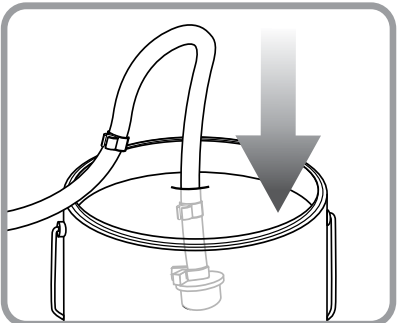

4. Turn Prime/Spray switch to Prime mode.

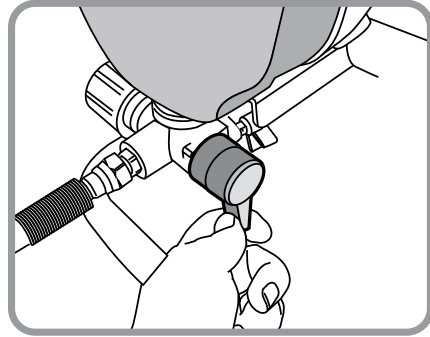

5. Plug in Sprayer and turn on power.

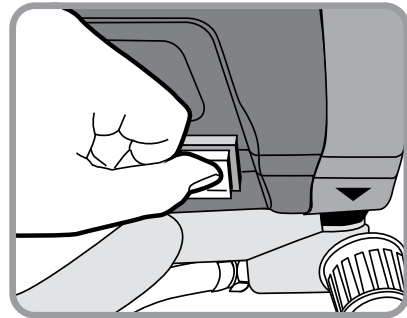

6. Adjust Pressure Control Knob to Prime/Clean setting.

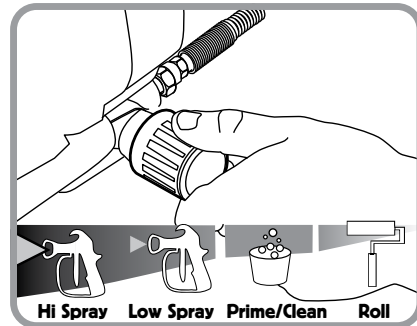

7. Sprayer will start pumping and water or flushing solvent as well as air bubbles will be purged from system. Let fluids discharge from Return Tube into waste bucket for 30 to 60 seconds then switch Power to Off.

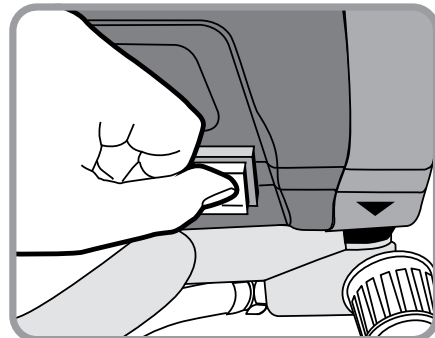

## NOTICE

**Clean the Sprayer IMMEDIATELY after use. Delayed or inadequate cleaning will permanently clog the Spray Gun. Warranty void if sprayer is not properly cleaned immediately after every use.**

8. Remove Suction Tube from water or flushing solvent and submerge in paint pail.

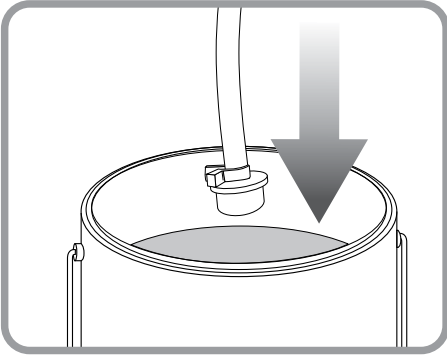

9. Switch Power to On.

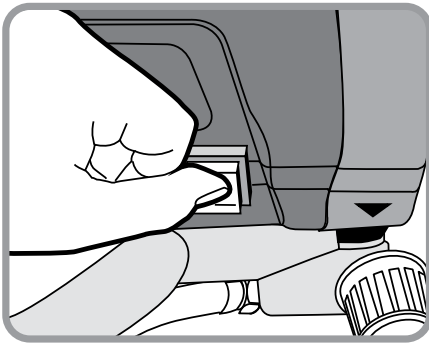

10. Paint should work itself from Suction Tube to Sprayer to Return Tube until paint discharges from Return Tube. Point gun into waste bucket and pull trigger.

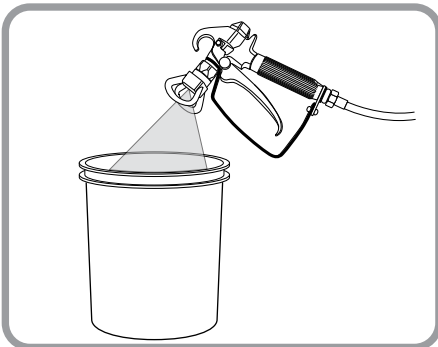

11. Turn Spray/Prime Switch to Spray mode and continue to spray into waste bucket.

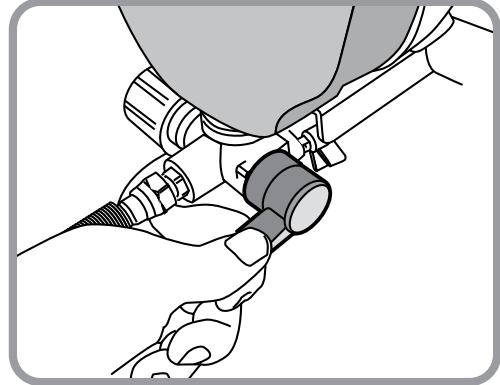

12. Stop spraying and activate trigger lock.

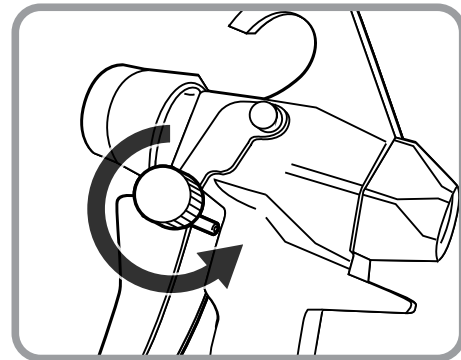

13. Remove the Return Tube from the waste bucket and clip to Suction Tube and submerge in paint pail.

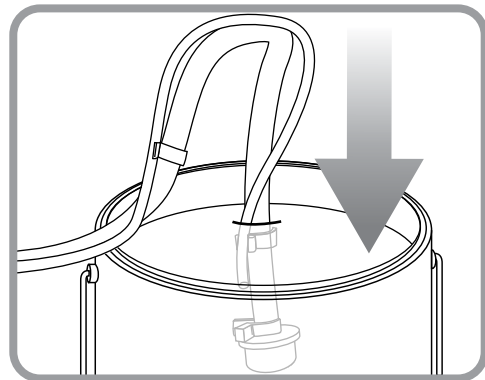

14. If the motor stops, the pump and tubes are primed. If it does not stop, repeat priming steps.

15. Start Painting.

## NOTICE

Clean the Sprayer IMMEDIATELY after use. Delayed or inadequate cleaning will permanently clog the Spray Gun. Warranty void if sprayer is not properly cleaned immediately after every use.

### Painting

Before painting, ensure the Sprayer has been primed (see Priming and Startup steps) and verify that Nozzle Tip is aligned properly.

**Note:** Remove or cover objects that you want to protect from overspray and paint mist.

1. Once primed, adjust nozzle to Spray setting.

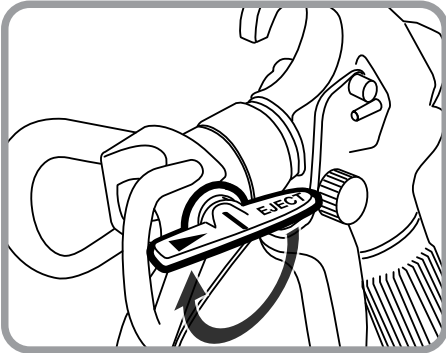

2. Start spraying at the lowest setting on the Pressure Control Knob and increase pressure as needed by turning clockwise to create a good spray pattern.

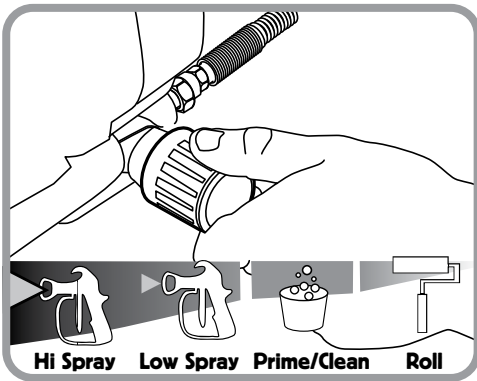

### Painting Techniques

Before painting, ensure the Sprayer has been primed (see Priming and Startup steps) and verify that Nozzle Tip is aligned properly. Keep the gun approximately 1 foot from the surface.

1. Keep gun straight and move arm across at a steady rate while staying one foot from the surface.

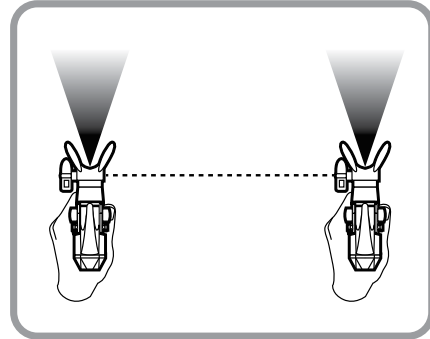

2. Do not fan the gun or paint will be uneven.

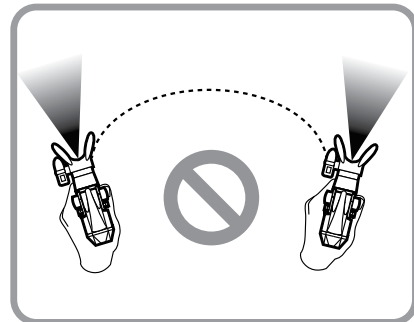

3. Overlap strokes by half, always aim stroke at bottom edge of last stroke.

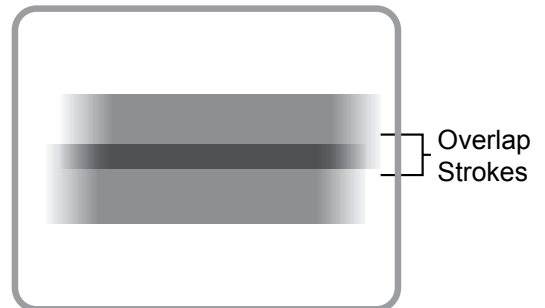

## NOTICE

Clean the Sprayer IMMEDIATELY after use. Delayed or inadequate cleaning will permanently clog the Spray Gun. Warranty void if sprayer is not properly cleaned immediately after every use.

### Clearing Spray Tip

Occasionally, the Spray Gun Tip will become clogged with paint. Follow these instructions to clear Spray Gun Tip.

1. Switch power off and set Trigger Lock.

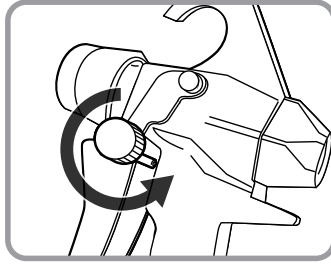
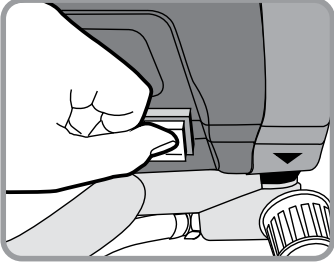

2. Adjust nozzle to clean setting.

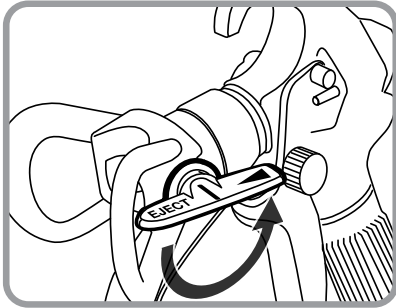

3. Turn Spray/Prime Switch to Spray mode.

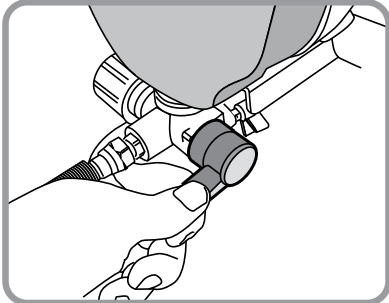

4. Turn power on.

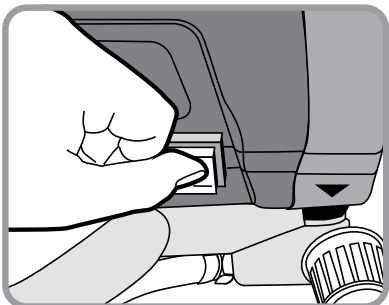

5. Unlock Trigger.

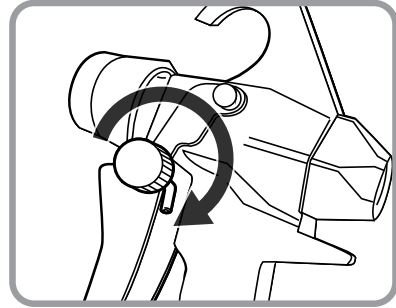

6. Spray into waste bucket until clog clears.

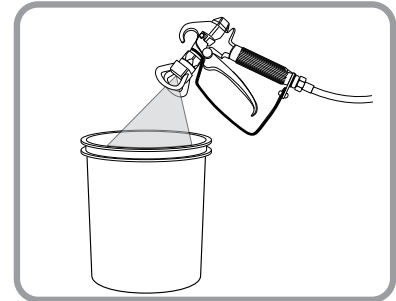

7. Release Trigger and engage Trigger Lock.

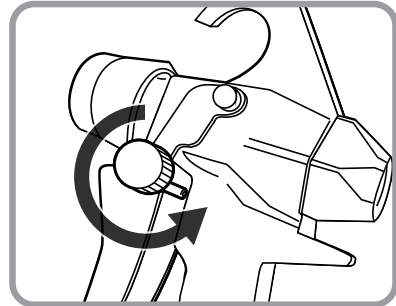

8. Adjust nozzle to Spray mode.

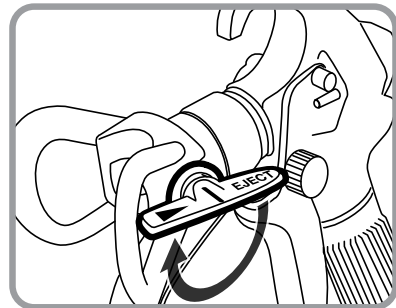

## NOTICE

Clean the Sprayer IMMEDIATELY after use. Delayed or inadequate cleaning will permanently clog the Spray Gun. Warranty void if sprayer is not properly cleaned immediately after every use.

### Cleaning

1. Relieve pressure and drain paint from Tubes.

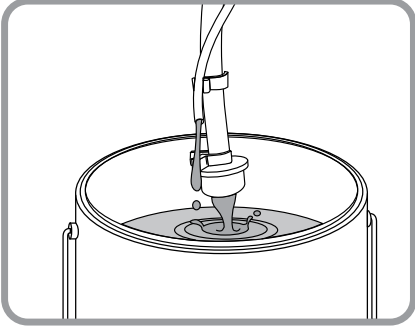

2. Separate tubes.

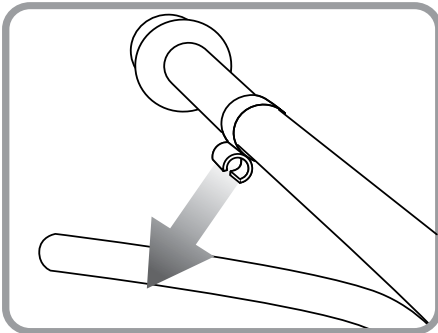

3. Place Return Tube in empty waste bucket.

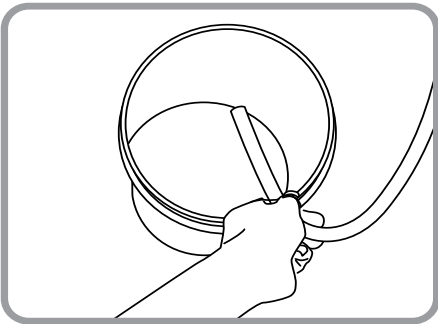

4. Submerge Suction Tube in water or flushing fluid.

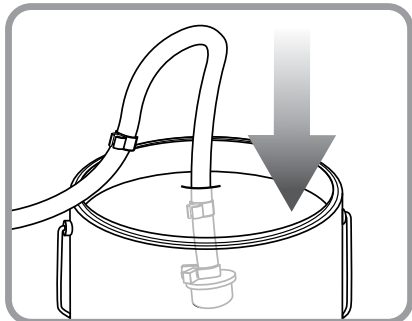

5. Unthread Spray Tip and remove.

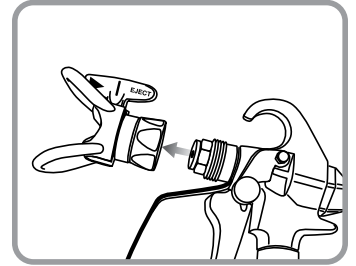
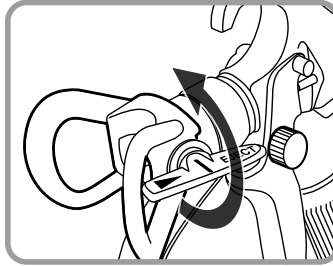

6. Turn to Spray mode.

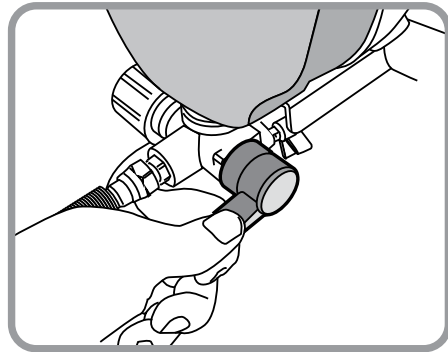

7. Switch power to on.

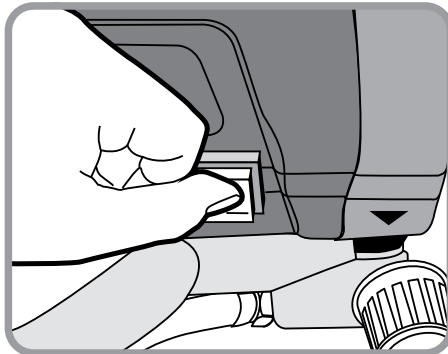

8. Spray paint into paint pail.

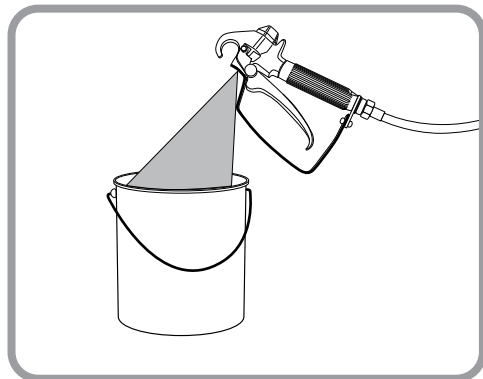



## NOTICE

Clean the Sprayer IMMEDIATELY after use. Delayed or inadequate cleaning will permanently clog the Spray Gun. Warranty void if sprayer is not properly cleaned immediately after every use.

9. Change to waste bucket as paint thins.

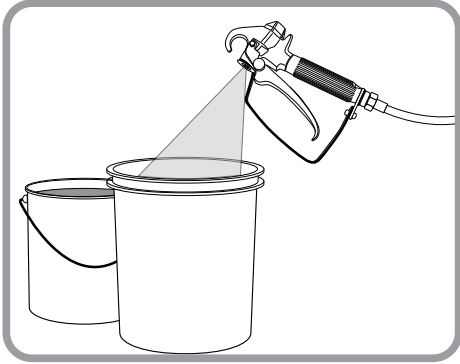

13. Remove trigger guard from housing.

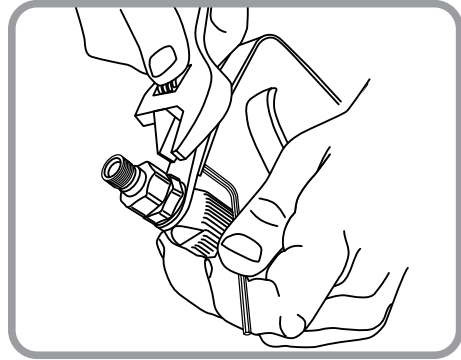

10. Turn to Prime mode.

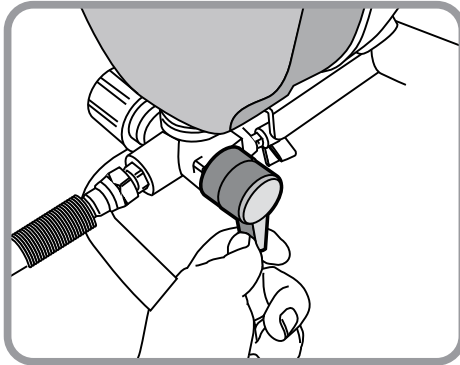

14. Unscrew nut.

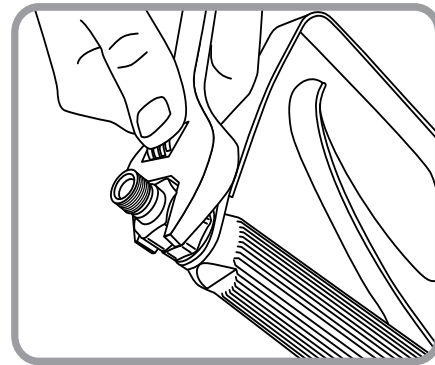

11. Continue to flush until clear.

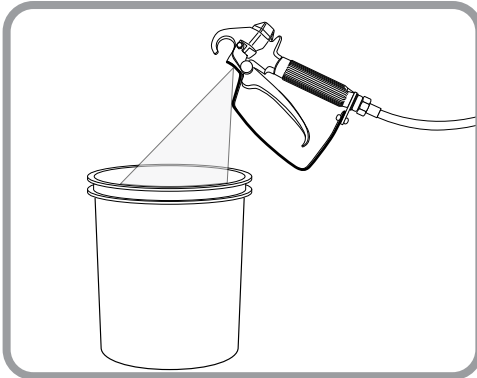

15. Remove filter.

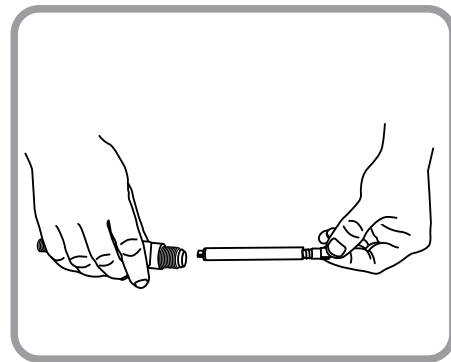

12. Release trigger, turn power off, and relieve pressure.



16. Clean all parts in warm, soapy water or flushing fluid with a bristled brush.

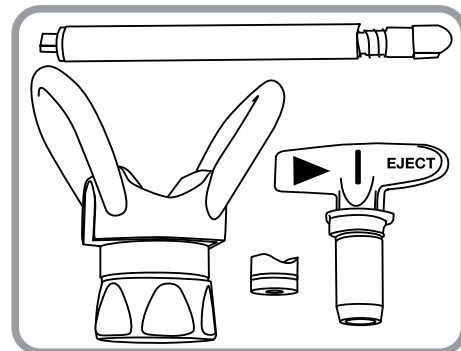

## NOTICE

Clean the Sprayer IMMEDIATELY after use. Delayed or inadequate cleaning will permanently clog the Spray Gun. Warranty void if sprayer is not properly cleaned immediately after every use.

### Long Term Storage

When cleaning for long term storage (more than 48 hours).

It is very important that the Paint Sprayer is not stored with any water or water-based material left in the Pump, Hose, Tubes, or Spray Gun. This will corrode the product.

1. Clean the Sprayer before storage.  
See "Cleaning" on pages 16-17.

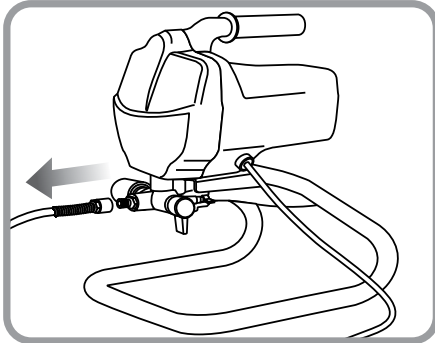

2. Remove paint hose if not already removed.

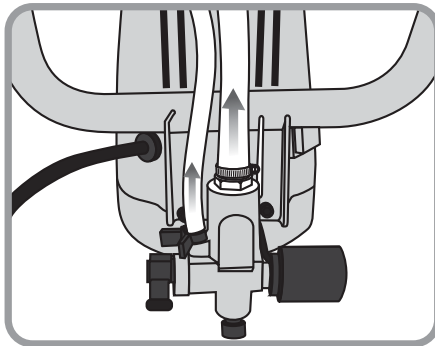

3. Turn the unit over and loosen the Clamps from both Tubes, then disconnect them from the Pump Body.

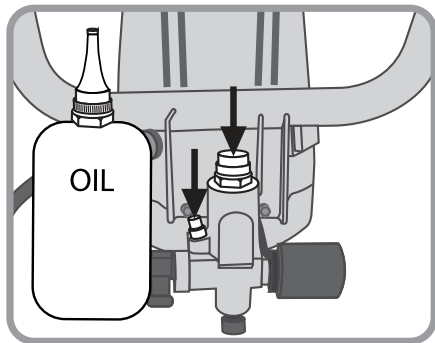

4. Add one ounce of light household oil into each inlet.

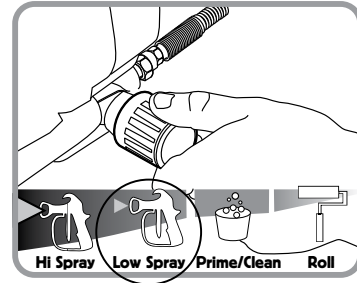

5. Turn Prime/Spray switch to Spray.

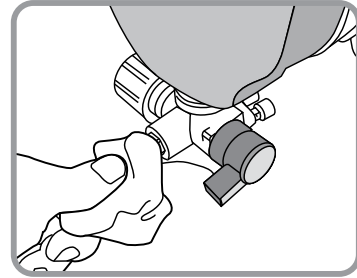

6. Hold a rag over the paint hose outlet.
7. Switch Power to ON for five seconds, then turn the power OFF.

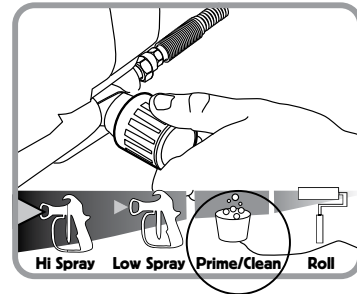

8. Turn Prime/Spray switch to Prime, this will keep storage fluids in sprayer.

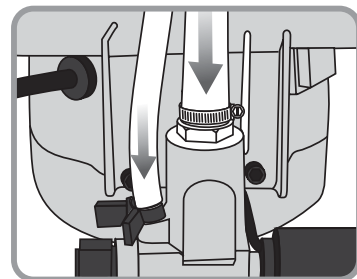

9. Replace the Tubes and secure with the Clamps.
10. Wipe the sprayer with a clean cloth. Store in a clean dry location out of reach of children.

## NOTICE

Clean the Sprayer IMMEDIATELY after use. Delayed or inadequate cleaning will permanently clog the Spray Gun. Warranty void if sprayer is not properly cleaned immediately after every use.

## Disposal Instructions



Improper disposal of paint is against the law and a health and environmental hazard. Dispose of paint through local recycling facility. Visit [www.earth911.com](http://www.earth911.com) to find a facility near you.

## Troubleshooting

Problem	Possible Causes	Likely Solutions
Decreased output.	Obstructed trigger.	Clean around trigger to ensure movement.
Inconsistent paint flow, blobs and splatters.	1. Clogged Spray Tip or damaged/clogged Fluid Filter. 2. Contaminated paint.	1. Clean, adjust or replace Spray Tip or Fluid Filter. 2. Remove paint and filter it.
Paint surface is bumpy or has orange peel texture.	1. Paint is applied too thick. 2. Incorrect paint volume. 3. Insufficient air pressure. 4. Paint gun too far from paint surface during spraying.	1. Paint must be thinned properly before spraying. 2. Adjust Fluid Control Knob. 3. Adjust Air Regulator and Air Adjustment Valve. 4. Hold spray gun closer to surface during spraying.
Paint sags or runs.	1. Excess thinning of paint. 2. Paint applied too thick. 3. Paint gun too close to work surface. 4. Uneven or hesitant motion of spray gun. 5. Excess overlapping of each spray stroke.	1. Recheck paint viscosity. Add unmixed paint to thicken mixture. 2. Apply thinner coats, allowing paint to get tacky between coats. 3. Move spray gun further back from paint surface when applying paint. 4. Keep spray gun moving during painting. Hesitations can cause sags or runs. 5. Overlap each stroke to keep the coverage even, but be aware that you are adding coat thickness by overlapping.
Blotchy surface (blushing) or uneven color.	1. Paint dries too slowly. 2. Uneven paint application. 3. Work material absorbs paint unevenly.	1. Use less thinner or add a drier. 2. Start each stroke off the work material and overlap each stroke consistently. 3. Use a conditioner or sealer coat before applying the finish coat.
Spots on surface with light center (fish eyes).	1. Paint mixture too thin. 2. Improper primer or incompatible surface. 3. Surface contamination.	1. Add undiluted paint to thicken mixture. 2. Check manufacturer's recommendations for primer or compatible surfaces. 3. Clean surface thoroughly with thinner before applying paint.
Spots on surface with dark center (contamination).	1. Dust or dirt on surface. 2. Insufficiently sanded. 3. Raised grain.	1. Clean surface with compressed air or tack cloth before painting. 2. Sand wood to a sufficiently fine grit before painting. 3. Wipe wood surface with thinner to raise grain, then sand with fine grit to knock off "hairs".

## Parts List

Part	Description	Qty
1	Spray Gun	1
2	Paint Hose	1
3	Base Frame	1
4	Hex Bolt (M6x4)	2
5	Pressure Relief Valve Label	1
6	Housing Cover	1
7	Output Gear Bushing	2
8	Rolling Bearing	1
9	Output Pole	1
10	Gear	1
11	Middle Gear Bushing	2
12	Output Gear	1
13	Pin (5x12)	2
14	Screw	1
15	Paint Outlet	1
16	O-Ring (10x1.8)	1
17	Output Spring	1
18	Mandrel	1
19	Steel Ball (6.4)	1
20	Seal Seat	1
21	Output Pusher	1
22	Pump Body	1
23	Nylon Washer	1
24	Insert Block	1
25	Pressure Relief Valve	1
26	Nylon Ring	1
27	O-Ring (5x1.8)	1
28	Pressure Relief Pole	1
29	Pressure Relief Spring	1
30	Spring Seat	1
31	Pin (3x8)	1
32	Control Valve Seat	1
33	Prime/Spray Valve	1
34	Pin	1
35	Nylon Cable Tie	1
36	Inlet Spring Holder	1
37	Input Spring	1
38	Steel Ball (12.7)	1
39	Input Seal	1
40	Input Washer	1
41	O-Ring (17x1.8)	1
42	Paint Input Adaptor	1
43	Pressure Relief Plug	1
44	Small Clamp	1
45	Large Clamp	1
46	Return Tube	1
47	Suction Tube	1
48	Clip	3
49	Inlet Pipe Lock Ring	1
50	Filtrate Seat Assembly	1
51	Wire label	1
52	Power Cord	1
53	Locking Ring	1
54	Screw (M4x14)	2

Part	Description	Qty
55	Wire Fastening Seat	1
56	Label	1
57	Hex Bolt (M6x10)	3
58	Housing	1
59	Label	1
60	Motor Assembly	1
61	Power Switch	1
62	Pin (3x12)	1
63	Hex Bolt (M5x14)	4
64	Elastic Washer	4
65	O-Ring (12.5x2.65)	2
66	Joint Stopper	1
67	Position Washer	1
68	Wave Washer	1
69	White Seal	3
70	Black Seal	2
71	Copper Washer	1
72	O-Ring (22.5x1.8)	2
73	Connector	1
74	Copper Guide Bushing	1
75	Piston	1
76	Lock Sleeve	1
77	White Seal	2
78	Pressure Control Pin	1
79	O-Ring (8.8x1.9)	1
80	O-Ring (27x2.4)	1
81	Hex Bolt (M3x10)	1
82	Pressure Seal Cover	1
83	Micro Switch	1
84	Micro Switch Cover	1
85	Pressure Control Switch	1
86	Switch Cover	1
87	Pressure Adjusting Spring	1
88	Spring Pusher	1
89	Pressure Control Label	1
90	Pressure Knob	1
91	Pressure Control Bolt	1
92	Label	1
93	Handle Grip	1
94	Handle	1
95	Hex Bolt (M6x30)	2
96	PCB Supporter	1
97	Wire Connector	1
98	Nylon Cable Tie	1
99	Safety Cover	1
100	PCB Assembly	1
101	Tapping Screw	2
102	Power Cord Fixer	1
103	Hex Bolt (M4x20)	2
104	Cup	1
105	Bolt (M5x20)	1
106	Pole Stopper	1
107	Small Gear Washer	1

# Assembly Diagram

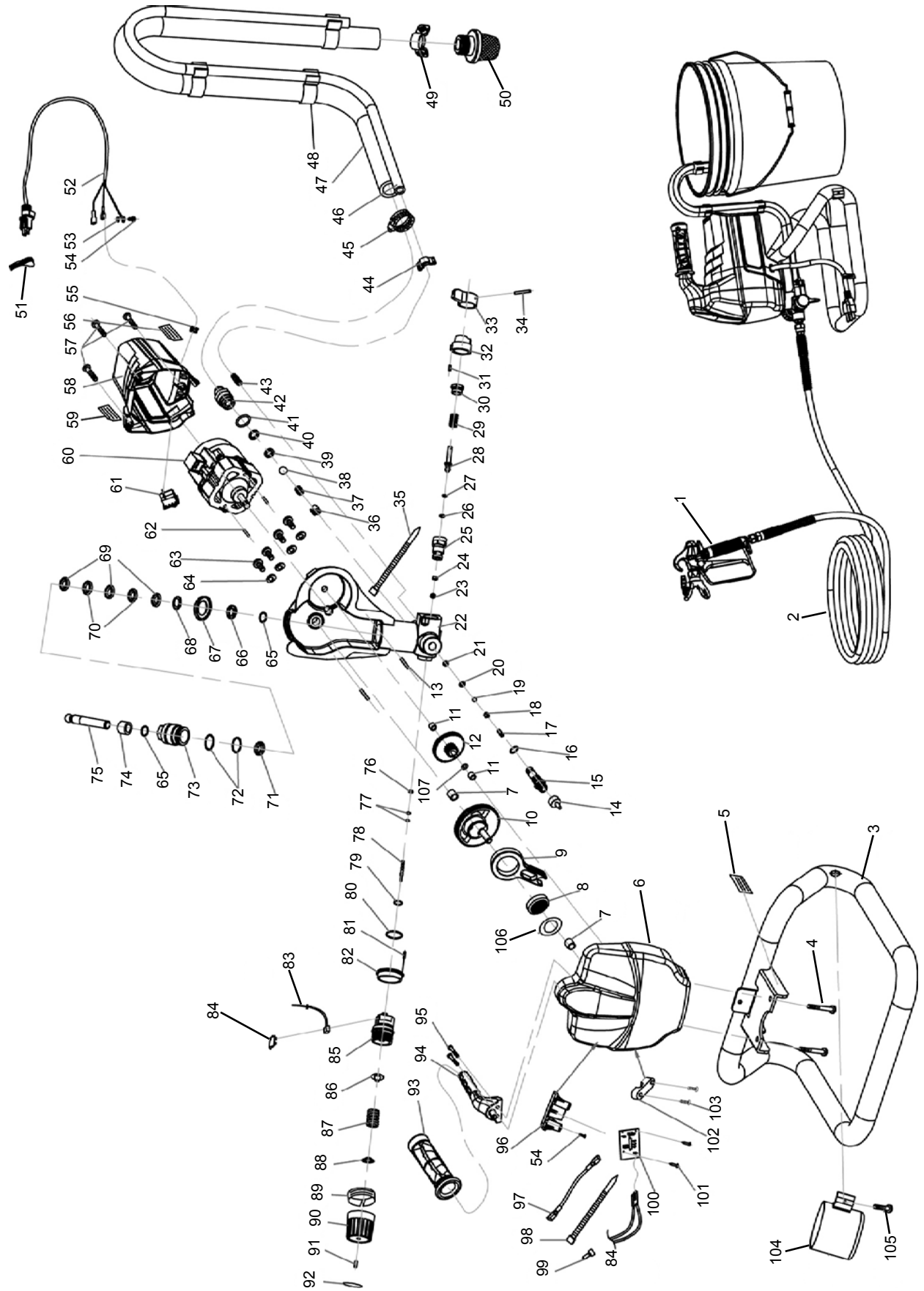

## Limited 90 Day Warranty

Harbor Freight Tools Co. makes every effort to assure that its products meet high quality and durability standards, and warrants to the original purchaser that this product is free from defects in materials and workmanship for the period of 90 days from the date of purchase. This warranty does not apply to damage due directly or indirectly, to misuse, abuse, negligence or accidents, repairs or alterations outside our facilities, criminal activity, improper installation, normal wear and tear, or to lack of maintenance. We shall in no event be liable for death, injuries to persons or property, or for incidental, contingent, special or consequential damages arising from the use of our product. Some states do not allow the exclusion or limitation of incidental or consequential damages, so the above limitation of exclusion may not apply to you. THIS WARRANTY IS EXPRESSLY IN LIEU OF ALL OTHER WARRANTIES, EXPRESS OR IMPLIED, INCLUDING THE WARRANTIES OF MERCHANTABILITY AND FITNESS.

To take advantage of this warranty, the product or part must be returned to us with transportation charges prepaid. Proof of purchase date and an explanation of the complaint must accompany the merchandise. If our inspection verifies the defect, we will either repair or replace the product at our election or we may elect to refund the purchase price if we cannot readily and quickly provide you with a replacement. We will return repaired products at our expense, but if we determine there is no defect, or that the defect resulted from causes not within the scope of our warranty, then you must bear the cost of returning the product.

This warranty gives you specific legal rights and you may also have other rights which vary from state to state.

## PLEASE READ THE FOLLOWING CAREFULLY

THE MANUFACTURER AND/OR DISTRIBUTOR HAS PROVIDED THE PARTS DIAGRAM IN THIS MANUAL AS A REFERENCE TOOL ONLY. NEITHER THE MANUFACTURER NOR DISTRIBUTOR MAKES ANY REPRESENTATION OR WARRANTY OF ANY KIND TO THE BUYER THAT HE OR SHE IS QUALIFIED TO MAKE ANY REPAIRS TO THE PRODUCT OR THAT HE OR SHE IS QUALIFIED TO REPLACE ANY PARTS OF THE PRODUCT. IN FACT, THE MANUFACTURER AND/OR DISTRIBUTOR EXPRESSLY STATES THAT ALL REPAIRS AND PARTS REPLACEMENTS SHOULD BE UNDERTAKEN BY CERTIFIED AND LICENSED TECHNICIANS AND NOT BY THE BUYER. THE BUYER ASSUMES ALL RISK AND LIABILITY ARISING OUT OF HIS OR HER REPAIRS TO THE ORIGINAL PRODUCT OR REPLACEMENT PARTS THERETO, OR ARISING OUT OF HIS OR HER INSTALLATION OF REPLACEMENT PARTS THERETO.

## Specifications

Electrical Input	120V~ / 60Hz / 7A
Motor	5/8 HP
Max. Working Pressure	3000 PSI
Outlet	1/4"-NPSM
Paint Hose	25' Long



3491 Mission Oaks Blvd. • PO Box 6009 • Camarillo, CA 93011 • (800) 444-3353

[www.harborfreight.com](http://www.harborfreight.com)