

AMERICAN AUDIO

VERSADECK

Featuring:



MIDI
COMPLIANT



Anti-Shock



DIGITAL
SCRATCH

seamless loop

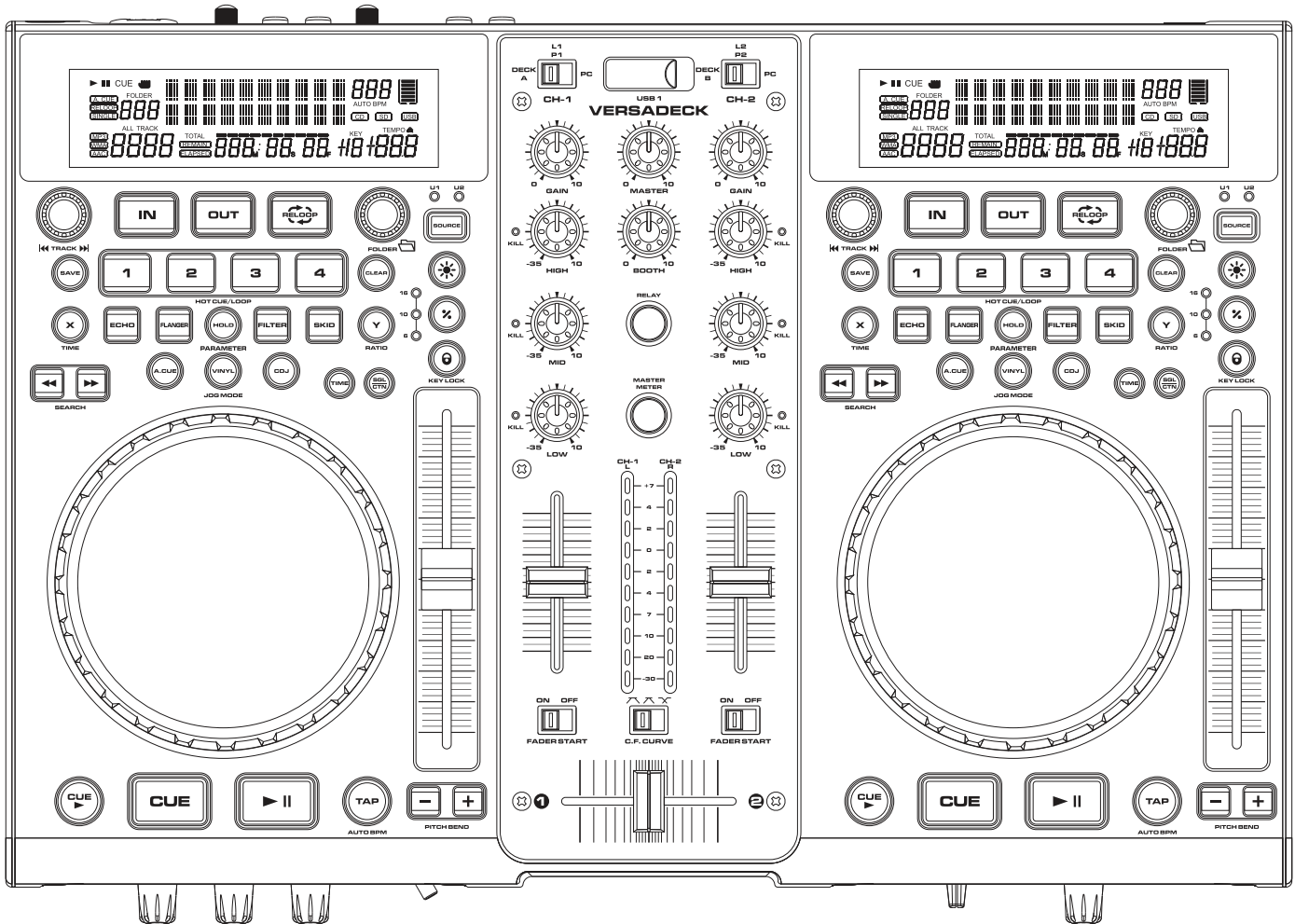

User Guide and Reference Manual

CONTENTS

<i>IMPORTANT INFORMATION</i>	3
<i>ELECTRICAL PRECAUTIONS</i>	4
<i>SAFETY INSTRUCTIONS</i>	5
<i>UNPACKING</i>	6
<i>CUSTOMER SUPPORT</i>	6
<i>FEATURES</i>	7
<i>SET-UP INSTALLATION</i>	8
<i>FUNCTIONS AND CONTROLS</i>	
<i>PLAYER</i>	9
<i>MIXER</i>	13
<i>FRONT & REAR PANEL</i>	15
<i>VFD DISPLAY</i>	17
<i>INTERNAL MENU</i>	19
<i>BASIC OPERATIONS</i>	
<i>LOADING EJECTING USB DEVICE</i>	20
<i>TRACK SELECTION</i>	20
<i>STARTING PLAYBACK</i>	21
<i>PAUSING PLAYBACK</i>	21
<i>FRAME SEARCH</i>	21
<i>SETTING A CUE POINT</i>	22
<i>CREATING A SEAMLESS LOOP</i>	23
<i>CHANGING TIME DISPLAY</i>	24
<i>BANKBUTTONS</i>	25
<i>PITCH ADJUSTMENTS</i>	
<i>PITCH SLIDER</i>	26
<i>PITCH BENDING</i>	27
<i>JOG WHEEL FUNCTIONS</i>	29
<i>BUILT-IN EFFECTS</i>	31
<i>PLAYLIST OPERATION</i>	33
<i>RELAY (FLIP-FLOP™)</i>	33
<i>DATABASE BUILDER</i>	34
<i>MIDI MAP</i>	37
<i>MIXER SET-UP</i>	40
<i>CROSSFADER REPLACEMENT</i>	42
<i>TROUBLESHOOTING</i>	43
<i>WARRANTY</i>	44
<i>SPECIFICATIONS</i>	45

IMPORTANT INFORMATION

IMPORTANT SAFETY ITEMS FOR U.S.A. & CANADA MODEL ONLY

WARNING:

TO PREVENT FIRE OR SHOCK HAZARD,
DO NOT EXPOSE THIS MEDIA PLAYER TO
WATER OR MOISTURE

CAUTION:

1. Handle the power supply cord carefully. Do not damage or deform; it may cause electric shock or malfunction when used. Hold plug attachment when removing from wall outlet. Do not pull on the cord.
2. To avoid electric shock, do not open the top cover when the unit is plugged in. If problems occur with the unit, call your local American Audio® dealer.
3. Do not place metal objects or spill liquid inside the media player. Electric shock or malfunction may occur.



CAUTION

**Do not open -
Risk of electric shock**



CAUTION: TO REDUCE THE RISK OF ELECTRIC SHOCK, DO NOT REMOVE THE COVER RACK. THERE ARE NO USER SERVICEABLE PARTS INSIDE REFER SERVICE TO YOUR AUTHORIZED American Audio DEALER.



The lightning flash with an arrow triangular symbol is intended to alert the user to the presence of non insulated "dangerous voltage" within the products enclosure, and may be of sufficient magnitude to constitute a risk of electric shock.



The exclamation point triangular symbol is intended to alert the user to the presence of important operating and maintenance (servicing) instructions in the user manual accompanying the media player.

CAUTION

TO PREVENT ELECTRIC SHOCK DO NOT USE THIS (POLARIZED) PLUG WITH AN EXTENSION CORD, RECEPTACLE OR OTHER OUTLET UNLESS THE BLADES CAN BE CAREFULLY INSERTED TO PREVENT BLADE EXPOSURE

CAUTION:

USE OF CONTROLS OR ADJUSTMENTS OTHER THAN THOSE SPECIFIED HEREIN MAY RESULT IN HAZARDOUS RADIATION EXPOSURE

THE MEDIA PLAYER SHOULD NOT BE ADJUSTED OR REPAIRED BY ANYONE EXCEPT PROPERLY QUALIFIED SERVICE PERSONNEL.

NOTE:

This unit may cause interference to radio and television reception.

Please carefully read and understand the instructions in this manual thoroughly before attempting to operate this unit. These instructions contain important safety information regarding the use and maintenance of this unit. Take special care to follow all warning symbols and labels both on the unit and printed in this manual. Also, Please keep this manual with the unit, for future reference.

CAUTION: TO PREVENT ELECTRIC SHOCK DO NOT USE THIS (POLARIZED) PLUG WITH AN EXTENSION CORD, RECEPTACLE, OR OTHER TYPE OF ELECTRICAL OUTLET UNLESS THE WIDE BLADES CAN BE CAREFULLY INSERTED INTO A MATCHING WIDE SLOT.

ATTENTION: POUR PREVENIR LES CHOCS ELECTRIQUES NE PAS UTILISER CETTE FICHE POLARISEE AVEC UN PROLONGATEUR, UNE PRISE DE COURANT OU UNE AUTRE SORTIE DE COURANT, SAUF SI LES LAMES PEUVENT ETRE INSEREES A FOND SANS EN LAISSER AUCUNE PARTIE A DECOUVERT.

ELECTRICAL SAFETY PRECAUTIONS

ELECTRICAL PRECAUTIONS



The lightning flash with arrowhead symbol, within an equilateral triangle, is intended to alert the user to the presence of uninsulated "dangerous voltage" within the product's enclosure that may be of sufficient magnitude to constitute a risk of electric shock to persons.



CAUTION: TO REDUCE THE RISK OF ELECTRIC SHOCK, DO NOT REMOVE THE COVER (OR BACK). THERE ARE NO USER SERVICEABLE PARTS INSIDE. REFER SERVICE TO YOUR AUTHORIZED AMERICAN AUDIO® SERVICE TECHNICIAN.



The exclamation point within an equilateral triangle is intended to alert the user to the presence of important operating and maintenance (servicing) instructions in the literature accompanying the appliance.

IMPORTANT SAFETY INSTRUCTIONS

READ INSTRUCTIONS — All the safety and operating instructions should be read before the product is operated.

RETAIN INSTRUCTIONS — The safety and operating instructions should be retained for future reference.

HEED WARNINGS — All warnings on the product and in the operating instructions should be adhered to.

FOLLOW INSTRUCTIONS — All operating and use instructions should be followed.

CLEANING — The product should be cleaned only with a polishing cloth or a soft dry cloth. Never clean with furniture wax, benzine, insecticides or other volatile liquids since they may corrode the cabinet.

ATTACHMENTS — Do not use attachments not recommended by the product manufacturer as they may cause hazards.

WATER AND MOISTURE — Do not use this product near water — for example, near a bathtub, wash bowl, kitchen sink, or laundry tub; in a wet basement; or near a swimming pool; and the like.

ACCESSORIES — Do not place this product on an unstable cart, stand, tripod, bracket, or table. The product may fall, causing serious injury to a child or adult, and serious damage to the product. Use only with a cart, stand, tripod, bracket, or table recommended by the manufacturer, or sold with the product. Any mounting of the product should follow the manufacturer's instructions, and should use a mounting accessory recommended by the manufacturer.

CART — A product and cart combination should be moved with care. Quick stops, excessive force, and uneven surfaces may cause the product and cart combination to overturn.



VENTILATION — Slots and openings in the cabinet are provided for ventilation and to ensure reliable operation of the product and to protect it from overheating, and these openings must not be blocked or covered. The openings should never be blocked by placing the product on a bed, sofa, rug, or other similar surface. This product should not be placed in a built-in installation such as a bookcase or rack unless proper ventilation is provided or the manufacturer's instructions have been adhered to.

POWER SOURCES — This product should be operated only from the type of power source indicated on the marking label. If you are not sure of the type of power supply to your home, consult your product dealer or local power company.

LOCATION — The appliance should be installed in a stable location.

NONUSE PERIODS — The power cord of the appliance should be unplugged from the outlet when left unused for a long period of time.

GROUNDING OR POLARIZATION

- If this product is equipped with a polarized alternating current line plug (a plug having one blade wider than the other), it will fit into the outlet only one way. This is a safety feature. If you are unable to insert the plug fully into the outlet, try reversing the plug. If the plug should still fail to fit, contact your electrician to replace your obsolete outlet. Do not defeat the safety purpose of the polarized plug.

- If this product is equipped with a three-wire grounding type plug, a plug having a third (grounding) pin, it will only fit into a grounding type power outlet. This is a safety feature. If you are unable to insert the plug into the outlet, contact your electrician to replace your obsolete outlet. Do not defeat the safety purpose of the grounding type plug.

POWER-CORD PROTECTION - Power-supply cords should be routed so that they are not likely to be walked on or pinched by items placed upon or against them, paying particular attention to cords at plugs, convenience receptacles, and the point where they exit from the product.

OUTDOOR ANTENNA GROUNDING — If an outside antenna or cable system is connected to the product, be sure the antenna or cable system is grounded so as to provide some protection against voltage surges and built-up static charges. Article 810 of the National Electrical Code, ANSI/NFPA 70, provides information with regard to proper grounding of the mast and supporting structure, grounding of the lead-in wire to an antenna discharge unit, size of grounding conductors, location of antenna-discharge unit, connection to grounding electrodes, and requirements for the grounding electrode. See Figure A.

LIGHTNING — For added protection for this product during a lightning storm, or when it is left unattended and unused for long periods of time, unplug it from the wall outlet and disconnect the antenna or cable system. This will prevent damage to the product due to lightning and power-line surges.

POWER LINES — An outside antenna system should not be located in the vicinity of overhead power lines or other electric light or power circuits, or where it can fall into such power lines or circuits. When installing an outside antenna system, extreme care should be taken to keep from touching such power lines or circuits as contact with them might be fatal.

OVERLOADING — Do not overload wall outlets, extension cords, or integral convenience receptacles as this can result in a risk of fire or electric shock.

OBJECT AND LIQUID ENTRY - Never push objects of any kind into this product through openings as they may touch dangerous voltage points or short-out parts that could result in a fire or electric shock. Never spill liquid of any kind on the product.

SERVICING — Do not attempt to service this product yourself as opening or removing covers may expose you to dangerous voltage or other hazards. Refer all servicing to qualified service personnel.

DAMAGE REQUIRING SERVICE - Unplug this product from the wall outlet and refer servicing to qualified service personnel under the following conditions:

- When the power-supply cord or plug is damaged.
- If liquid has been spilled, or objects have fallen into the product.
- If the product has been exposed to rain or water.
- If the product does not operate normally by following the operating instructions. Adjust only those controls that are covered by the operating instructions as an improper adjustment of other controls may result in damage and will often require extensive work by a qualified technician to restore the product to its normal operation.
- If the product has been dropped or damaged in any way.
- When the product exhibits a distinct change in performance — this indicates a need for service.

REPLACEMENT PARTS — When replacement parts are required, be sure the service technician has used replacement parts specified by the manufacturer or have the same characteristics as the original part. Unauthorized substitutions may result in fire, electric shock, or other hazards.

SAFETY CHECK - Upon completion of any service or repairs to this product, ask the service technician to perform safety checks to determine that the product is in proper operating condition.

WALL OR CEILING MOUNTING — The product should not be mounted to a wall or ceiling.

HEAT — The product should be situated away from heat sources such as radiators, heat registers, stoves, or other products (including amplifiers) that produce heat.

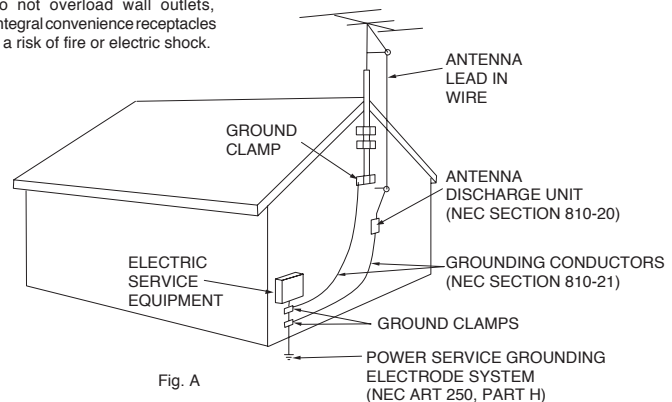

Fig. A

NEC — NATIONAL ELECTRICAL CODE

SAFETY INSTRUCTIONS

1. Read Instructions - All the safety and operating instructions should be read before you operate the system. The safety and operating instructions should be saved for future reference.
2. Heed Warnings - All warnings on the system and in the operating instructions should be adhered to.
3. Water and Moisture - The system should not be used near water - for example, near a bath tub, kitchen sink, laundry tub, in a wet basement or near a swimming pool, etc.
4. Ventilation - The system should be situated so that its location or position does not interfere with its proper ventilation. For example, the system should not be situated on a bed, sofa, rug, or similar surface that may block the ventilation openings; or, placed in a built-in installation, such as a bookcase or cabinet that may impede the flow of air through the ventilation openings.
5. Heat - The system should be situated away from heat sources such as radiators, heat registers, stoves, or other appliances (including amplifiers) that produce heat.
6. Power Sources - The system should be connected to a power supply only of the type described in the operating instructions or as marked on the system.
7. Servicing - The user should not attempt to service the system beyond that described in the operating instructions. All other servicing should be referred to qualified service personnel. The system should be serviced by qualified service personnel when:
 - A. The power-supply cord or the plug has been damaged.
 - B. Objects have fallen, or liquid has been spilled into the system.
 - C. The system has been exposed to rain or water.
 - D. The system does not appear to operate normally or exhibits a marked change in performance.

The serial and model number for this unit is located on the rear panel. Please write down the numbers here and retain for future reference.

Model No. _____

Serial No. _____

Purchase Notes:

Date of Purchase _____

Dealer Name _____

Dealer Address _____

Dealer Phone _____

UNPACKING

Every VERSADECK has been thoroughly tested and has been shipped in perfect operating condition. Carefully check the shipping carton for damage that may have occurred during shipping. If the carton appears to be damaged, carefully inspect your system for any damage and be sure all equipment necessary to operate the system has arrived intact. In the event damage has been found or parts are missing, please contact our toll free customer support number for further instructions. Please do not return the system to your dealer without first contacting customer support.

INTRODUCTION

Introduction:

Congratulations and thank you for purchasing the American Audio® VERSADECK. This VERSADECK is a representation of American Audio's continuing commitment to produce the best and highest quality audio products possible at an affordable price. Please read and understand this manual completely before attempting to operate your new media player. This booklet contains important information concerning the proper and safe operation of your new media player.

Customer Support:

American Audio® provides a toll free customer support line, to provide set up help and answer any question should you encounter problems during your initial set up or operation. You may also visit us on the web at www.AmericanAudio.us for any comments or suggestions. Service Hours are Monday through Friday 8:00 a.m. to 4:30 p.m. Pacific Standard Time.

Voice: (800) 322-6337
Fax: (323) 582-2941
E-mail: support@americanaudio.us

To purchase parts online visit <http://parts.americandj.com>

Caution! There are no user serviceable parts inside this media system. Do not attempt any repairs yourself, without being instructed to do so by an authorized American Audio service technician. Doing so will void your manufacturer's warranty. In the unlikely event your media player may require service, please contact American Audio® customer support.

Do not discard the packing carton in the trash. Please recycle when ever possible.

SET-UP PRECAUTIONS

Please be sure to make any connections before plugging the player in to an electrical outlet. All fader and volume controls should be set to zero or minimum position, before the system is switched on. If the system has been exposed to drastic temperature fluctuation (e.g. after transportation), do not switch on the system immediately. The arising condensation of water might damage your device. Leave the device switched off until it has reached room temperature.

Operating Determinations:

- When installing this system, please make sure that the device is not exposed or will not be exposed to extreme heat, moisture or dust!
- Do not operate the system in extremely hot (more than 30°/86°F) or extremely cold (less than 5°C/40°F) surroundings.
- Keep the unit out of direct sunlight and away from heaters.
- Operate the system only after becoming familiar with its' functions. Do not permit operation by persons not qualified for operating the unit. Most damages are the result of unprofessional operation.

MAIN FEATURES

- Plays Mp3/WAV* files from either USB Stick or SD/SDHC Card via USB Card Reader
- ID3 Track Recognition
- Auto cue
- 1/75th second frame search
- Real time cue (“Cue on the Fly”)
- 8 different speed scan (4 Forward/4 Reverse)
- Pitch display
- RCA Stereo outputs
- Large bright VFD display can be viewed from wide angles.
- Folder Search for Mp3's
- Seamless Loop (uninterrupted loop playback)
- Sampler (Forward & Reverse Sampling)
- 10 Second Digital Anti-Shock
- Flip-Flop (Relay Playback) **(b)**
- Jog Wheel Pitch Bend +/-100%
- Jog Wheel Sensitivity Adjustment
- Selectable Single or Continuous Play
- 4 Programmable Cue (Bank) Buttons
- Adjustable Pitch Percentages: +/-6%, +/-10%, or +/-16%
- Instant Start within 10ms (sound is produced immediately when the PLAY button is pressed)
- Real Time Scratch Play
- Skid Effect
- Filter Effect
- Echo Effect
- Flanger Effect
- System Lock
- Music Master tempo
- Fader “Q” Start Control **(a)**
- Cue Mixing
- 3 Band EQ per channel
- Front & Rear Access Mic Jack
- Master & Booth Outputs
- 2 Phono & 2 Line Level Inputs
- Balanced XLR Outputs
- Headphone Jack w/ Volume Control

* WAV Files: 1411Kbps PCM

-
- (a) FADER “Q” START CONTROL:** Set up your VERSADECK as described in the set-up section of this manual. After set up is completed load your players. By moving the mixer’s crossfader from left to right you can start and pause each players playback functions. For Example, when using the VERSADECK player, if your mixer’s crossfader is all the way to the left (player one is playing, player two is in cue or pause mode), and you move the fader at least 20% to the right, player two (2) will begin to play. When the crossfader is to the right, and you move it 20% to the left, player one (1) will begin to play. You can create great effects similar to scratching with this feature. After storing cue points on each side of the player, different songs may quickly be recalled by moving the mixer crossfader back and forth. New cue points can be easily selected on the VERSADECK player (see setting cue points page 22). “Q” Start control is easy to use and mastering this feature will help you create amazing effects with your music.
- (b) RELAY (FLIP-FLOP):** Connect your VERSADECK player as described in the set-up section of this manual. This feature will start the next player once one (1) player has ended. For example, if player one (1) is playing a track and it ends, player two (2) will instantly begin to play. You may set RELAY to play track to track or folder to folder. For more information on this feature, see RELAY (FLIP-FLOP™) on page 33.

SET-UP

USB INFORMATION:

- The **VERSADECK** will only read MP3 files or WAV files.
- If you are using a SD Card via USB SD Card reader, you must remove the USB SD Card reader first to change SD Card's. Please do not remove the SD Card from the USB SD Card reader while the USB card reader is still connected to the unit.

NOTE: For higher quality MP3 files (more than 128 kbps) American Audio recommends "High Speed" SD Cards. Using high speed cards will ensure the best performance with your American Audio Player.

- Only supports FAT/FAT32 formatted devices.

NOTE: If the **VERSADECK** cannot read your USB device, please make sure that it FAT formatted.

1. Checking the Contents

Be sure your **VERSADECK** was shipped with the following:

- 1) **VERSADECK** Professional media player/mixer
- 2) Software CD
- 3) Warranty card
- 4) Power Cord

CAUTION:

- To avoid severe damage to the unit, be sure the power is off when making connections to the unit.

System Power Up Sequence:

1. Turn ON the **VERSADECK**.
2. Next turn ON your speakers.

System Power Up Sequence with connected mixer, amp, active speakers, or external device:

1. Turn ON the amp, mixer, speakers, or any external device first.
2. Next turn ON the **VERSADECK**.

CAUTION:

- The VFD is designed to be clearly visible within the angles shown in **Figure 1**. Mount the unit so that the visual angle is within this range.

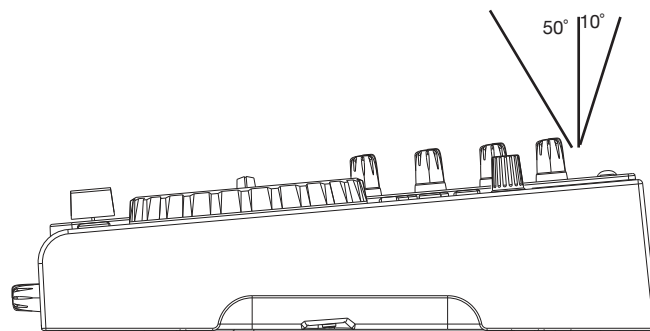
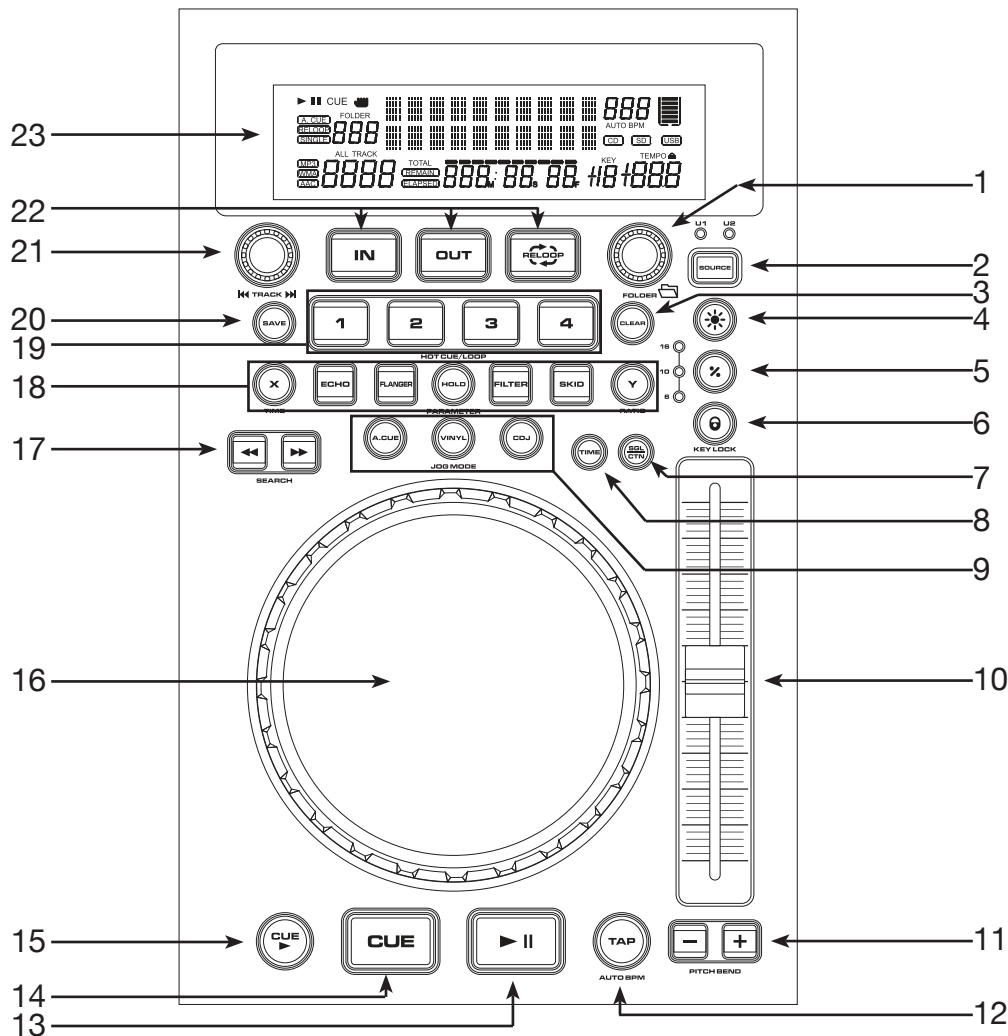

Figure 1

Figure 2



A. TOP UNIT PLAYER CONTROLS (FIGURE 2)

1. FOLDER SEARCH KNOB - Turning this knob will let you search for your desired folder. Turn the knob to scroll backward and forward through folders. The folder number you are currently in will be shown in the VFD.

2. SOURCE SELECT BUTTON - This button lets you toggle between USB Port 1 & USB Port 2. This selector lets you choose which source will play on either side. The corresponding LED's located above the button will verify which source is active. The source selection can only be done in PAUSE mode.

3. CLEAR BUTTON - Use this button to clear the *BANK BUTTONS (19)*. Press this button and then press the *BANK BUTTON (19)* you would like to clear.

4. PITCH ON/OFF BUTTON - This button is used to switch the pitch function on and off. When the button LED is lit the *PITCH SLIDER (10)* is active. When the button LED is not lit, the *PITCH SLIDER (10)* is not active. The pitch percentage can be changed between 6%, 10%, and 16%; 6% will allow the least amount of pitch manipulation and 16% will allow the most amount of pitch manipulation.

5. PITCH PERCENTAGE SELECTOR - Press this button to select pitch range percentages of 6%, 10%, and 16%. See adjusting the *PITCH SLIDER'S RANGE* on page 26.

6. TEMPO LOCK FUNCTION - This button activates the TEMPO LOCK function. This function allows

you to use the **PITCH SLIDER** to speed up or slow down playback speed without altering the tonal pitch of the track. When this function is not engaged the original tonal pitch of the track will be altered giving you the "chipmunk" effect when a track is played at a high rate of speed, or the "James Earl Jones" effect when a track is slowed to much.

7. SGL/CTN - This function allows you to choose between single track play or continuous track play (all tracks in order). This function also operates in **RELAY (FLIP-FLOP)** mode, when **RELAY** is activated.

8. TIME BUTTON - The **TIME** button will switch the time value described in the *TIME METER* between **ELAPSED PLAYING TIME & TRACK REMAINING TIME**.

9. JOG WHEEL MODE BUTTONS - The **JOG WHEEL** has 3 effect functions;

- **A. Cue Scratch Mode:**

In Playback Mode - While in playback mode the **JOG WHEEL** can be used to return the unit to the last set **CUE** point. Simply touch the **JOG WHEEL** surface and the unit will immediately return you to the last set **CUE** point and start playback.

In Pause Mode - When the player is paused, touching the **JOG WHEEL** surface will start playback and will continue to playback until the **JOG WHEEL** is released. Once the **JOG WHEEL** is released the unit will return to the last **CUE** point.

- **Vinyl Mode:** When this mode is active, use the **JOG WHEEL** to simulate turntable scratching.

- **CDJ Mode:**

In Playback Mode - When this mode is active the **JOG WHEEL** can work as a pitch bend during playback. Turning the wheel clockwise will increase the pitch percentage up to 100%, and turning the wheel in the counter-clockwise direction will decrease the pitch percentage down to -100%. The pitch bend will be determined on how long you turn the jog wheel continuously.

In Pause Mode - When the player is paused, you can use the **JOG WHEEL** to frame search.

10. PITCH SLIDER - This slider is used to adjust the playback pitch percentage. The slider is a set adjustment and will remain set until the pitch slider is moved or the pitch function has been turned off. This adjustment can be made with or without a disc in the drive. The pitch adjustment will remain even if a disc has been removed and will reflect on any other disc loaded into the player. That is to say, if you set a +2% pitch on one disc, remove that disc and insert another, that disc too will have a +2% pitch. The amount of pitch being applied will be displayed in the *VFD (23)*.

11. (+) PITCH BEND BUTTON - The **(+)** pitch bend function creates a momentary "BUMP" in the audio's BPM's (Beats per minute) while it is playing. This will allow you to match the beats between the two playing deck's or any other music source. Remember, this is a momentary function. When you remove your finger from this button, the BPM's will automatically return to *PITCH SLIDERS (10)* selected pitch. Holding down this button will give a maximum of +16% pitch.

(-) PITCH BEND BUTTON - The **(-)** pitch bend function creates a momentary "Slow Down" in the audio's BPM's (Beats per minute) while it is playing. This will allow you to match the beats between the two playing deck's or other playing music source. Remember, this is a momentary function. When you remove your finger from the pitch button, the BPM's will automatically return to *PITCH SLIDERS (10)* pitch value. Holding down this button will give a maximum of -16% pitch. Use this function to slow to another playing music source. Be sure to notice that this function is a momentary pitch adjustment, for a more precise adjustment use the *PITCH SLIDER (10)* to match the BPM's with another playing music source.

12. TAP BUTTON - Press this button to switch between manual BPM and Auto BPM. When in manual BPM mode, tap this button to the beat of the current track. Press and hold this button for at least 3 secs. to switch to Auto BPM. The BPM mode you are currently in is displayed in the VFD.

13. PLAY/PAUSE BUTTON - Each press of the *PLAY/PAUSE BUTTON* causes the operation to change from play to pause or from pause to play. While in play mode the blue play LED will glow, and while in pause mode the blue play LED will flash.

14. CUE BUTTON - Pressing the *CUE* button during playback immediately pauses playback and returns the track to the last set cue point (see setting a CUE POINT, page 22). The red CUE LED will glow when the unit is in cue mode. The LED will also flash every time a new CUE POINT is set. The *CUE* button can be held down to momentarily play music. When you release the *CUE* button it instantly returns to the CUE POINT.

15. CUE PLAY BUTTON - Press this button to instantly start playback from the last CUE point.

16. JOG WHEEL - This wheel has four functions;

- The jog wheel will act as a frame search control when the audio is in pause or cue mode and CDJ Mode is activated. Frame search allows to find your desired place to set a cue point.
- The wheel also works as a pitch bend during Playback with the CDJ mode active. Turning the wheel clockwise will increase the pitch percentage up to 100%, and turning the wheel in the counter-clockwise direction will decrease the pitch percentage down to -100%. The pitch bend will be determined on how long you turn the jog wheel continuously.
- The jog wheel is used to apply the scratch effect when Vinyl Mode is active.
- The jog wheel is used in conjunction with the *TIME (18)* and *RATIO (18) BUTTONS* to adjust and set effect and sample parameters, see page 32.

17. SEARCH BUTTONS -

◀◀ This search button allows you to quickly scan backwards through a track.

▶▶ This search button allows you to quickly scan forwards through a track.

18. EFFECTS AND HOLD BUTTON -

PARAMETER TIME BUTTON - When this button is activated you can turn the *JOG WHEEL (16)* to adjust the parameter time value.

ECHO EFFECT - This button is used to activate and deactivate the Echo effect. The Echo effect adds an echo to your output signal. See BUILT-IN EFFECTS on page 31.

FLANGER EFFECT - This button is used to activate and deactivate the Flanger effect. The Flanger effect distorts the output signal and creates an effect similar to the frequency phasing in and out of each other.

HOLD BUTTON - This button has two functions:

Parameter Lock: This button allows you to lock any new parameter settings you set to the effects. The button LED will glow when the hold function is activated. When the hold selection is not active, any changes to the effect parameters will be momentary.

System Lock: If you press and hold the button for 3 seconds you will activate the System Lock. The button LED will flash when the HOLD function is active. To unlock the HOLD function press and hold the button for 3 seconds.

FILTER BUTTON - This button is used to activate and deactivate the Filter effect. The Filter effect tweaks the original sound to add different tonal definition. The effect is almost the same as

the PHASE effect.

SKID BUTTON - This button is used to activate and deactivate the Skid effect. The Skid effect simulates the sudden platter stop of a turntable, like pressing the stop button on a turntable.

PARAMETER RATIO BUTTON - When this button is activated you can turn the *JOG WHEEL (16)* to adjust the parameter ratio value.

19. MEMORY BANK BUTTONS 1-4 - These buttons are used to store either four (4) cue points or four (4) loops. Each BANK BUTTON can store either a loop or a cue point. When a loop is stored in a BANK BUTTON the button LED will glow green. When a Cue Point is stored, the button LED will glow red.

20. SAVE BUTTON - This button can be used in a couple of ways.

- Press this button to activate the Save mode, the SAVE BUTTON LED will glow when activated. After the Save mode is activated, press your desired *BANK BUTTON (19)* to store your cue point or playing loop.
- This button is also used to store your loops and cue points that are saved in the *BANK BUTTON (19)* to the system memory for next time. Press the SAVE BUTTON for 2 secs. and the button LED will flash. Your loops and cue points are now saved to the system memory.
- **RECALL MEMORY:** The player can store 4 programmed cue points or loops per track in the USB device. The memory points being stored in the USB device depend on the available memory space of the USB. These settings can be recalled at any time, even when an audio source has been removed and loaded at a later time.

To recall the bank memory with the USB device loaded: Press the SAVE BUTTON, the button LED will glow. Turn the *TRACK KNOB (21)* to select the track with the MEMORY BANKS that you would like to recall for the cue points or loops; when in the loop mode press the *RELOOP BUTTON (22)* to activate loop mode.

21. TRACK SEARCH KNOB - Turning this knob will let you search through tracks in your selected folder. Turn the knob to scroll backward and forward through tracks. You can also push the knob in and turn to jump 10 tracks forward or 10 tracks backward. The current track number will be shown in the VFD. Every push of the knob will display the Artist, Track Title, Genre, and Track Bit Rate.

22. IN, OUT, & RELOOP BUTTONS -

OUT BUTTON - This button is used to set the ending point of a loop. A loop is started by pressing the IN BUTTON, and pressing the *OUT BUTTON* to set the loop ending point. The loop will continue to play until the *OUT BUTTON* is pressed once again.

IN BUTTON - “CUE ON THE FLY” - This function allows you to set a CUE POINT (see CUE POINT page 22) without music interruption (“on the fly”). This button also sets the starting point of a seamless loop (see SEAMLESS LOOP).

RELOOP BUTTON - If a SEAMLESS LOOP has been made (see setting a SEAMLESS LOOP on page 23), but the player is not actively in SEAMLESS LOOP mode (a loop is not playing), pressing the *RELOOP BUTTON* will instantly reactivate the SEAMLESS LOOP mode. To exit the loop, press the *OUT BUTTON (22)*. LOOP will appear in the *VFD DISPLAY (23)* when the RELOOP function is available.

23. VFD DISPLAY - This high quality VFD display indicates all the various functions, as they are occurring. This display is viewable at several comfortable angles (see page 8). The display ICONS will be explained on page 17.

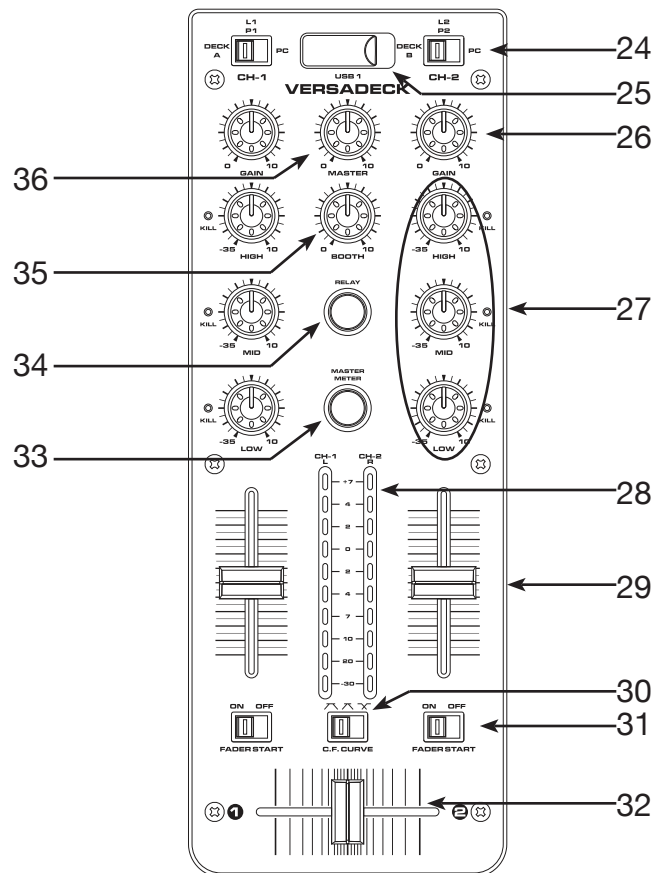

Figure 3

B. TOP UNIT MIXER CONTROLS (FIGURE 3)

24. SOURCE SELECTOR SWITCH - These switches are used to select the input source assigned to each channel. Each channel may only be assigned one input source at a time.

- CH1 selected to PC + CH2 selected to PC – the entire unite works as a MIDI controller.
- CH1 selected to PC + CH2 selected to DECK B – the Deck A works as a MIDI controller, the mixer works internally with Deck B.
- CH1 selected to PC + CH2 selected to LN2/ PH2 – the Deck A works as a MIDI controller, the mixer works internally with LN2/PH2 input.

25. USB PORT 1 - This is the first USB port where you can insert a USB stick, USB SD Card reader, or compatible external hard drive for playback. **VERY IMPORTANT: PLEASE SEE PAGE 8 FOR DETAILS REGARDING/USING USB DEVICES.**

26. CHANNEL GAIN CONTROL - This adjustment is used to adjust an audio source signal input gain for a channel. Never use the gain control to adjust output volume. Setting the gain level properly will ensure a clean output signal. To properly set the gain level controls:

1. Be sure the *MASTER VOLUME CONTROL* (36) is set to level 4.
2. Set the *CHANNEL FADER* (29) to level 8.
3. Begin playback on an audio source connected to the channel you are adjusting.
4. Use the *GAIN CONTROL* (26) to adjust an average output volume of +4 dB.
5. Repeat this step for all channels

27. EQUALIZER - All of the channels include a three-band signal EQ. These controls are used to increase or decrease the LOW's, MID's, and HI's of the output signal.

TREBLE CONTROL - This knob is used to adjust the treble levels of a channel allowing for a maximum

treble gain of +10dB or maximum decrease of -35dB. Turning the knob in a counter-clockwise direction will decrease the amount of treble applied to a channel signal, turning the knob in a clockwise direction will increase the amount of treble applied to a channel signal.

MIDRANGE CONTROL - This knob is used to adjust the midrange levels of a channel allowing for a maximum midrange gain of +10dB or maximum decrease of -35dB. Turning the knob in a counter-clockwise direction will decrease the amount of midrange applied to a channel signal, turning the knob in a clockwise direction will increase the amount of midrange applied to a channel signal.

BASS CONTROL - This knob is used to adjust the low frequency levels of a channel allowing for a maximum bass gain of +10dB or maximum signal decrease of -35dB. Turning the knob in a counter-clockwise direction will decrease the amount of bass applied to a channel signal, turning the knob in a clockwise direction will increase the amount of bass applied to a channel signal.

28. MASTER VOLUME LEVEL INDICATORS - The dual MASTER LEVEL LED indicators are used to detail the master output level. The meters will detail the output level of both the left and right channels.

29. CHANNEL FADER - These faders are used to control the output signal of any source assigned to its particular channel.

30. CROSSFADER CURVE ADJUSTMENT - The 3 position switch changes the behaviour of the crossfader action by changing the crossover curve slope. The 3 settings from left to right are: Quick Fade, Short Fade, and Normal Fade. (Quick Fade is usually used for scratching).

31. FADERSTART ON/OFF SWITCH - With this function you can use the crossfader to start and stop playback. The ON/OFF FADERSTART switch activates the fader start feature. When the fader start feature is activated sliding the *CROSSFADER* (32) from left to right will play or cue the player.

Example: Be sure the FADERSTART feature is activated on both channels. Slide the crossfader to the channel one position (full left) and begin playback on player one. Slide the crossfader to the channel position (far right). This will immediately trigger the play function on player two and return player one to cue mode. To return to normal fader operation turn the FADERSTART ON/OFF SWITCH to the OFF position.

32. REPLACEABLE CROSSFADER - This fader is used to blend the output signals of channels one and two together. When the fader is in the full left position (channel 1), the output signal of channel one will be controlled by the master volume level. The same fundamentals will apply for channel two. Sliding the fader from one position to another will vary the output signals of channels one and two respectively. When the crossfader is set in the center position, the output signals of both the channels one and channels two will be even.

33. MASTER INDICATOR BUTTON - This button is used to choose between master level indicators and channel level indicators.

34. RELAY BUTTON - This button activates the RELAY function.

35. BOOTH LEVEL - This knob is used to adjust the monitor volume output level. Turn the knob in a clockwise direction to increase the monitor volume.

36. MASTER VOLUME CONTROL - This rotary knob is used to control the master output level (volume). To avoid distorted output try to maintain an average output signal level +4 dB. Be sure this volume control is always set to zero before turning the unit on.

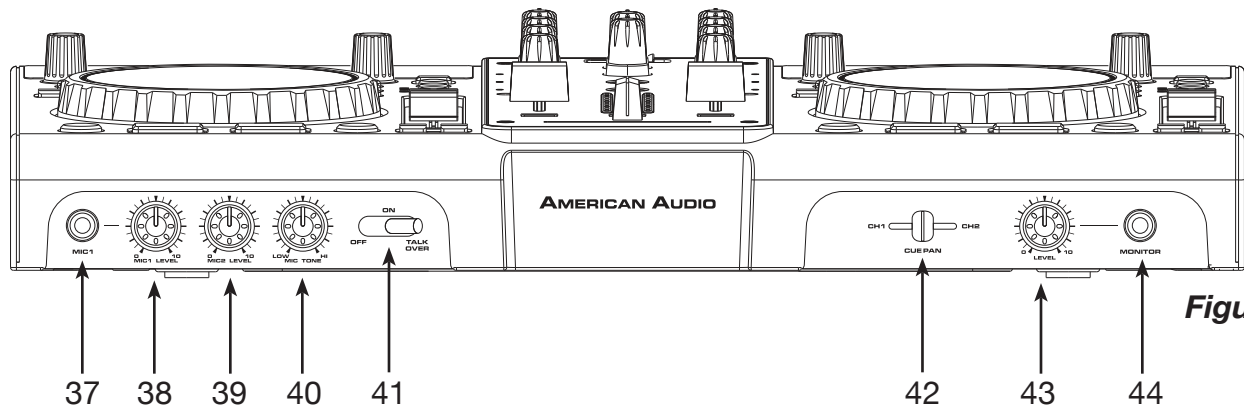

Figure 4

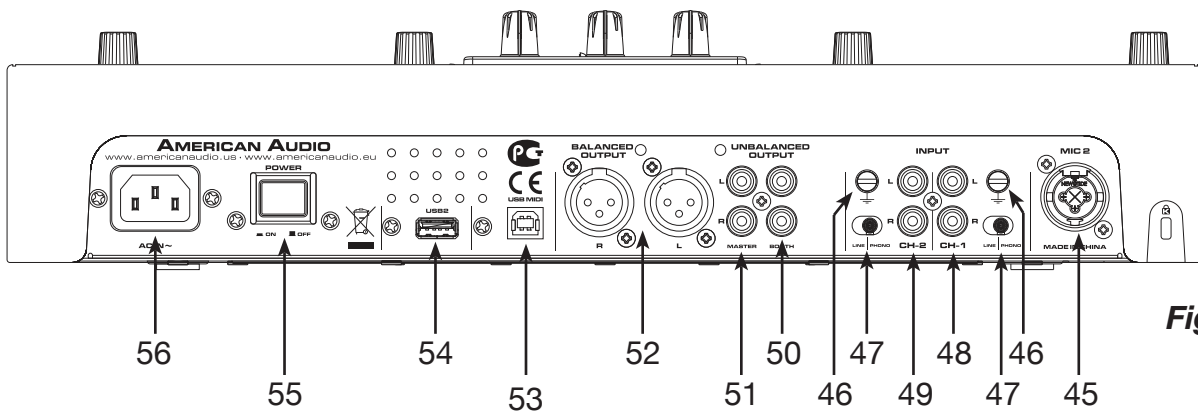

Figure 5

C. FRONT PANEL (FIGURE 4)

37. MICROPHONE 1 JACK - This jack accepts a standard 1/4 plug. The volume output level for this microphone will be controlled by its own respective *MIC KNOB* (38). **Note: We recommend that you use a 500-600ohm microphone for the best sound quality.**

38. MICROPHONE 1 VOLUME - This knob is used to regulate the microphone 1 output volume. Turning the knob in a clockwise direction will increase the volume level.

39. MICROPHONE 2 VOLUME - This knob is used to regulate the microphone 2 output volume. Turning the knob in a clockwise direction will increase the volume level.

40. MIC TONE CONTROL - This knob controls the frequency response of the microphone.

41. TALKOVER CONTROL - This function decreases all signal output except for the microphone signal.

42. CUE MIX - This slider is used to send a channels incoming signal to the headphones. Slide the slider to the left to monitor Channel 1, and to the right to monitor Channel 2. The cue level is adjusted by the *CUE LEVEL VOLUME KNOB* (43). Be sure the cue level is set to minimum before putting a pair of headphones on.

43. CUE LEVEL VOLUME KNOB - This knob is used to adjust the headphone volume output level. Turn the knob in a clockwise direction to increase the headphone volume.

44. HEADPHONE JACK - This jack is used to connect your headphones to the mixer allowing you to monitor the cue source. Use headphones only rated at 8 ohms to 32 ohms. Most DJ headphones are rated at 16 ohm, these are highly recommended. Always be sure the *CUE LEVEL VOLUME* (43) is set to minimum before you put the headphones on.

D. REAR PANEL (FIGURE 5)

45. MICROPHONE 2 JACK - This combo jack will accept a standard 1/4 plug or XLR 3-pin balanced male plug. The volume output level for this microphone will be controlled by the *MIC 2 VOLUME CONTROL KNOB* (39). **Note: We recommend that you use a 500-600ohm microphone for the best sound quality.**

46. GND (GROUND TERMINAL) - Be sure to connect turntable ground leads to either or both of the two available ground terminals. This will reduce the humming and popping noises associated with magnetic phono cartridges.

47. CHANNEL LINE LEVEL SELECTOR SWITCHES - These switches are used to change the voltage line levels of there respected Phono / Line RCA inputs jacks. When connecting turntables with magnetic cartridges to these jacks be sure the corresponding switch is in the "PHONO" position, and when using line level input devices such as CD players and tape decks be sure this switch is in the "LINE" position. Always be sure main power is shut off before changing the position of the Line Level Selector Switch.

48. CHANNEL 1 LINE/PHONO INPUT JACKS - CD players, Tape Decks and other line level instruments may be connected to these jacks. The *CHANNEL LINE LEVEL SELECTOR SWITCHES (47)* must be set to the correct position representing what is connected to the input jacks; i.e. if a turntable is connected to the input jacks the *CHANNEL LINE LEVEL SELECTOR SWITCHES (47)* must be set to "Phono". See *CHANNEL LINE LEVEL SELECTOR SWITCHES (47)* on this page. The red colored RCA jack represents the right channel input and the white represents the left channel input. Input volume will be controlled by channel one fader. The channel *SOURCE SELECTOR SWITCH (24)* must be in the "Line" position, to monitor any source connected to these jacks.

49. CHANNEL 2 LINE/PHONO INPUT JACKS - CD players, Turntables, and Tape Decks may be connected to these jacks. The *CHANNEL LINE LEVEL SELECTOR SWITCHES (47)* must be set to the correct position representing what is connected to the input jacks; i.e. if a turntable is connected to the input jacks the *CHANNEL LINE LEVEL SELECTOR SWITCHES (47)* must be set to "Phono". See *CHANNEL LINE LEVEL SELECTOR SWITCHES (47)* on this page. The red colored RCA jack represents the right channel input and the white represents the left channel input. Input volume will be controlled by channel two fader. The channel *SOURCE SELECTOR SWITCH (24)* must be in the "Line" position when CD players and any other line level instruments are connected to these jacks, to monitor any source connected to these jacks.

50. BOOTH OUTPUT JACKS - The VERSADECK offers a secondary output usually used to monitor your mix or to route to an outboard recording device. This output volume is controlled by the *BOOTH LEVEL KNOB (35)*.

51. RCA MASTER OUTPUTS - The RCA jacks send a low current unbalanced output signal. These jacks should only be used for shorter cable runs to signal processors or looping to another mixer. For cable runs greater than 15 feet use the *XLR BALANCED JACKS (52)*.

52. BALANCED XLR MASTER OUTPUT JACKS - The Master Output includes a pair of XLR Balanced jacks as well as a pair of *RCA UNBALANCED JACKS (51)*. The 3-pin XLR jacks send a high current balanced output signal. These jacks should be used when you will be driving an amp or other audio equipment with a balanced input, or whenever you will be running a signal line greater than 15 feet. Always, use these jacks whenever possible.

53. USB MIDI JACK - Use this jack to connect to a computer or a host USB player. After hooking up your computer with the USB 1.1 Connections, your computer will detect them respectively as an external sound card (USB Code). You may either play music on your computer or send it via the USB 1.1 Connections as a signal source to the device; alternatively, you may record the Master output signal on your computer using the USB 1.1 Connection.

NOTE: The sent Master Output Signal is not influenced by the position of the volume controls. To use the USB 1.1 Connection, please also refer to the operation manual of your computer and the programmers used.

54. USB PORT 2- This is the second USB port where you can insert a USB stick, USB SD Card reader, or compatible external hard drive for playback. **VERY IMPORTANT: PLEASE SEE PAGE 8 FOR DETAILS REGARDING/USING USB DEVICES.**

55. POWER BUTTON - This button is used to turn your unit's power on and off.

56. POWER CONNECTOR - This connection is used to connect your main power. Be sure that your local power matches the unit's required power. **NEVER REMOVE THE GROUND PRONG FROM THE POWER CABLE, DOING SO MAY RESULT IN IMPROPER OPERATION.**

Figure 6

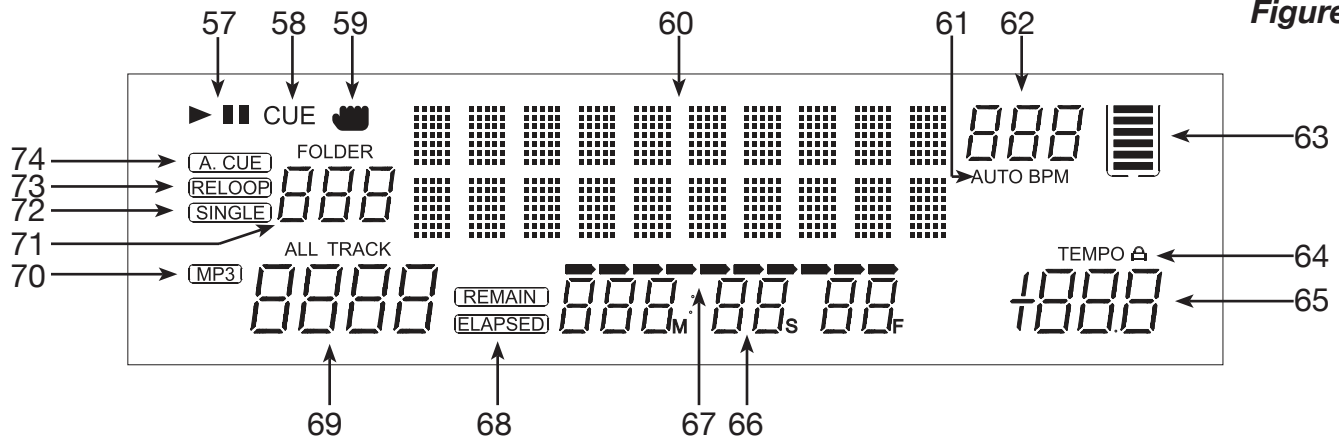

E. VFD DISPLAY PANEL (FIGURE 6)

57. PLAY/PAUSE INDICATOR - Either the play or pause indicator will glow depending which mode you are in.

58. CUE INDICATOR - This indicator will glow when the unit is in CUE mode and will flash every time a new CUE POINT is set.

59. TOUCH INDICATOR - This appears when anything touches the jog wheel.

60. CHARACTER DISPLAY - This will display the name of the track and album when a Mp3 disc is loaded.

61. AUTO BPM - This will indicate that the unit is in AUTO BPM mode.

62. BPM METER - This meter will display the BPM's of the current track.

63. MEMORY BUCKET - This meter serves two functions.

1. The bucket outline indicates your cue memory status. a full outline lets you know the cue memory is full. **Note: The search functions will not work unless all the bars are full.**

2. The five bars inside the bucket represent the digital buffer. Each bar represents 2 seconds.

64. TEMPO LOCK - This will indicate the Tempo Lock function is active.

65. PITCH METER - This meter will display the pitch percentage applied by the *PITCH SLIDER* (10).

66. TIME DISPLAY - These indicators detail the Minutes, Seconds, and Frames. The meter will display either the elapsed or remaining time of a track.

67. TIME BAR INDICATOR - This bar gives a visual approximation of a track's or disc's remaining time. This bar will begin to flash when a track is ending.

68. ELAPSED/REMAIN INDICATOR - This indicator is in direct reference to the *TIME METER* (66). When the ELAPSED indicator is displayed in the *VFD* (23), the time defined will refer to a single track's elapsed time. When "REMAIN" is indicated in the *VFD DISPLAY* (23) the *TIME DISPLAY* (66) in the *VFD* will define the current track's remaining time. The time mode is changed by the tapping on the *TIME BUTTON* (8).

69. TRACK INDICATOR - This indicator details the current track. The number displayed in the track indicator is a direct reference to the track in play, pause, or cue mode.

70. MP3 INDICATOR - This will indicate that MP3 files have been detected on the loaded USB device.

71. FOLDER INDICATOR - This indicator details the current folder you are in.

72. SINGLE INDICATOR - This indicates that the player is in single play mode, the track will play once and return to CUE mode. If the single indicator is not on the unit is in continuous mode. In continuous mode the drive will play all the remaining tracks.

73. RELOOP INDICATOR - Appears when LOOP is engaged or ready to be engaged.

74. AUTO CUE - This will indicate if the Auto Cue is on or off. Press and hold the *SGL/CTN (7)* for 1 sec. to turn the Auto Cue function on and off.

INTERNAL MENU

Press the *FOLDER KNOB (1)* for at least 3 secs. to enter the Internal Menu. Turn the *FOLDER KNOB (1)* to scroll through the different submenus. Turn either the *TRACK KNOB (21)* or *JOG WHEEL (16)* to change the submenu settings.

To save and exit the internal menu, turn the *FOLDER KNOB (1)* until G. Exit & Save is displayed, press the *TRACK KNOB (21)* to save your settings. If your settings were saved correctly, "Saving" will appear briefly in the *VFD (23)*.

NOTE: You can exit the Internal Menu anytime you want by pressing the *FOLDER KNOB (1)*, however your modified settings will not be save.

1. **PLAYLIST** - Normal / Title/ Artist / Album / Genre

The DATABASE BUILDER can generate "Playlist" for USB device. You can adjust various criteria in order to filter tracks in this setting. You can turn the *TRACK KNOB (21)* or *JOG WHEEL (16)* to scroll through the different settings; " Normal / Title/ Artist / Album / Genre". See page 33 Playlist Operation.

2. **REPEAT MODE** - 3 different modes: Play All Repeat / Folder Repeat / Track Repeat

3. **MIDI CH** - Setup MIDI Channel from 1 to 16 (Deck A - Mixer - Deck B).

4. **MIDI SETUP** -

- TAP = HOLD/TOGGLE
- I/O = Hide/DIS. (Hide/Display MIDI I/O value)

5. **CROSSFADER** -

- LOCK = To lock the crossfader in the middle of the two channels
- UNLOCK = The crossfader is back to normal status

6. **CROSSFADER REVERSE** -

- ON = Reverse the crossfader
- OFF = Normal Mode

7. **DISPLAY TIME** - 0.5 ~ 12.0 secs. (Line name start/stop time adjustment)

8. **SCROLL SPEED** - 50 ~ 2000 msec. (Adjust the scroll speed of the character display)

9. **SENSITIVITY** - Touch Wheel Sensitivity adjustment (Adjustment range is -20 ~ +20)

A. **INTENSITY** - VFD Brightness (Brightness Range is 1 ~ 4)

B. **A.CUE LEVEL** - Change the AUTO CUE level (Level range is -36 ~ -78dB)

C. **LINE SETUP** - Select VFD line name and display

D. **BIT RATE** - Display ON/OFF

E. **VERSION** - CXX (Control Version) DSPXX (DSP Version)

F. **LOAD DEFAULTS** - Press the *TRACK KNOB (21)* to change all settings back to default.

G. **EXIT & SAVE** - Exit & Save your custom settings until you power down. Press the *TRACK KNOB (21)* to exit & save.

NOTE:

SAVE: U1/U2, PITCH ON/OFF, PITCH RANGE, SGL/CTN, AUTO CUE, TIME MODE, HOLD, KEY LOCK, EFFECTS ON/OFF, PLAYLIST, REPEAT MODE, MIDI CHANNEL, MIDI SETUP, CROSSFADER, CROSSFADER REVERSE, DISPLAY TIME, SCROLL SPEED, SENSITIVITY, INTENSITY, A.CUE LEVEL, DISPLAY

DEFAULTS: U1/U2 (U1), PITCH (OFF), PITCH RANGE (10%), SGL,CTN (CTN), AUTO CUE (ON), TIME MODE (REMAIN), HOLD (OFF), KEY LOCK (OFF), EFFECTS (OFF), PLAYLIST (NORMAL), REPEAT MODE (ALL), MIDI CHANNEL (1-2-3), MIDI SETUP (TAP=HOLD, I/O=HIDE), CROSSFADER (UNLOCK) CROSSFADER REVERSE (OFF), DISPLAY TIME (3sec.), SCROLL SPEED (400ms), SENSITIVITY (0), INTENSITY (4), A.CUE LEVEL (-48dB), BIT RATE DISPLAY (ON)

BASIC OPERATIONS

1. LOADING/EJECTING A USB DEVICE

When loading a USB stick, USB card reader, or external hard drive make sure you are correctly lined up with the USB port and connect to the USB port. To disconnect a USB drive, stop playback and disconnect the USB connection. **VERY IMPORTANT: PLEASE SEE PAGE 8 FOR DETAILS REGARDING/USING USB DEVICES.**

CAUTION:

- **NEVER** remove a USB device while in PLAY mode.

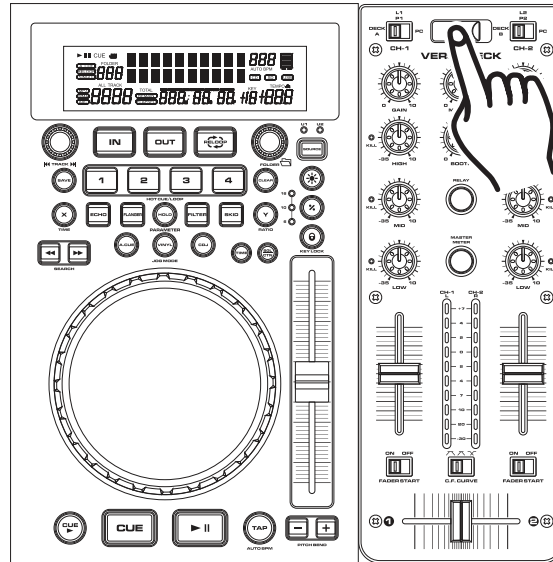

Figure 7

2. SELECTING TRACKS

Select a desired track by using the *TRACK KNOB (21)*. Turn the knob clockwise to move forward a track or counter-clockwise to move back a track. If you want to select a new track during playback (a track is already in play mode) the new track you selected will immediately begin playback as soon as the search operation is completed. You can also push the knob in and turn to jump 10 tracks forward or 10 tracks backward.

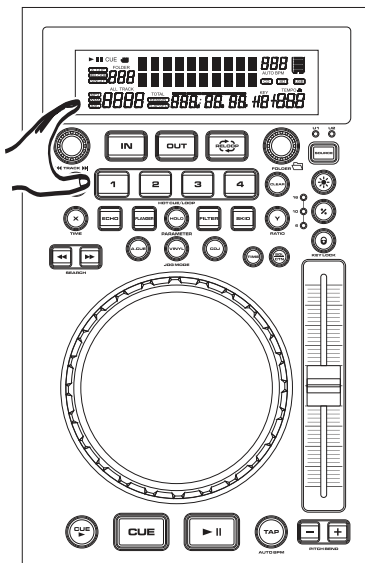

Figure 8: Turning the track button clockwise will skip forward to the next track.

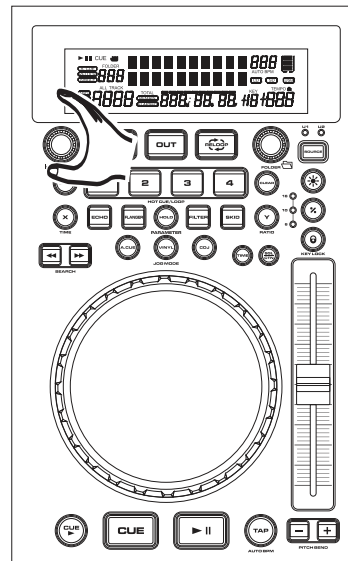

Figure 9: Turning the track button counter-clockwise will jump back to the previous track.

BASIC OPERATIONS (CONT.)

3. STARTING PLAYBACK - *Figure 10*

Load an audio source as described on page 20 (*LOADING/EJECTING USB DEVICE*). Pressing the *PLAY/PAUSE BUTTON (13)* with an audio device loaded will immediately start playback. The *PLAY (57)* indicator will glow as soon as playback begins. The point at which playback starts (cue point) will automatically be stored in the memory as the cue point. The unit will return to this cue point (the point at which playback started) when the *CUE BUTTON (14)* is pressed.

4. PAUSING - *Figure 10*

This function pauses playback at the exact same point the *PLAY/PAUSE BUTTON (13)* was pressed. Pressing the *PLAY/PAUSE BUTTON (13)* will switch between play and pause modes. When the unit is in pause mode the *PAUSE INDICATOR (57)* will show in the *VFD DISPLAY (23)*. The blue *PLAY/PAUSE BUTTON (13)* LED will also begin to flash repeatedly.

5. AUTO CUE

This function will automatically set a cue point to the first audio source that is loaded. The first set cue point will always be the beginning of track 1. If a new track is selected before the *PLAY BUTTON (13)* is pressed, a new *CUE POINT* will be set to reflect the new starting point.

6. STOPPING PLAYBACK - *Figures 10 & 11*

Stopping playback will not stop the drive mechanism, but merely pause or cue the track, this functions allows the unit to begin play instantly. The drive mechanism will only stop if a disc is ejected or the unit has gone in to sleep mode. There are two ways to stop (pause) playback:

- 1) Press the *PLAY/PAUSE BUTTON (13)* during playback. This will pause playback at the exact same point the *PLAY/PAUSE BUTTON (13)* was pressed.
- 2) Press the *CUE BUTTON (14)* during playback. This will pause playback and return the track to the last set cue point.

7. FRAME SEARCH

This feature allows you to scroll through a track frame by frame, allowing you to find and set a starting cue or loop point. To use the scroll function you must first be in Pause Mode (see section 4) or Cue Mode (see section 8). Once you are in Pause or Cue mode, turn the *JOG WHEEL (16)* to scroll through the track (Figure 12). Turning the wheel in a clockwise direction will advance the frame search and turning the wheel in a counter-clockwise direction rewinds the frame search. When you use the *JOG WHEEL (16)* the monitor (headphone level) function allows you to hear what you are scrolling through. Once you reach your desired starting point you can set a cue (starting) point by pressing the *PLAY/PAUSE BUTTON (11)* as in Figure 10. Pressing the *CUE BUTTON (14)* as in Figure 11 will now return you to the point you just set.

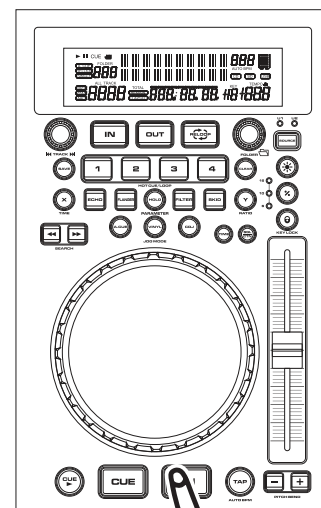

Figure 10

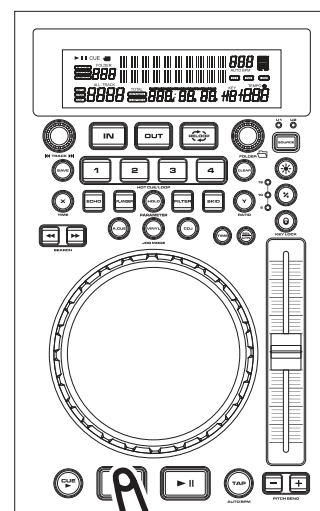

Figure 11

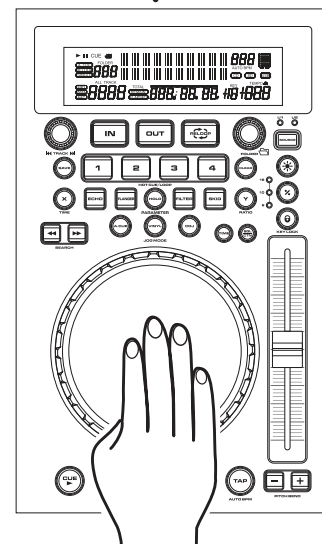
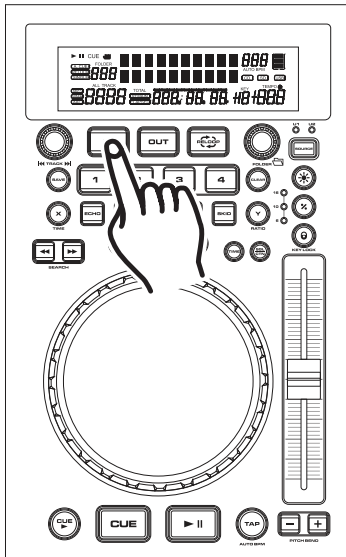

Figure 12

BASIC OPERATIONS (CONT.)

8. SETTING A CUE POINT

A cue point is the exact point playback will begin when the *PLAY/PAUSE* button (13) is pressed. You may set your cue points anywhere on a disc or in a track. There are three (3) ways to set and create a CUE point as detailed in figures 13, 14, & 15.



- 1) You may press the *IN BUTTON* (22) on the fly (while the disc is playing). This will set a CUE Point without music interruption. Pressing the *CUE BUTTON* (14) will now return you to the same point that you pressed the *IN BUTTON* (22).

Figure 13

- 2) You may also use the *JOG WHEEL* (16) to set a cue point. While a disc is in PAUSE or CUE mode, use the *JOG WHEEL* (16) to scroll through a track and find your desired starting point. Once you have found your desired CUE point press the *PLAY BUTTON* (13) to set your cue point. Pressing the *CUE BUTTON* (14) will now return you to this exact point.

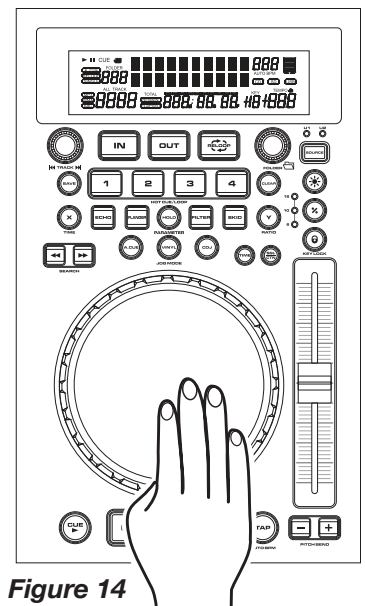

Figure 14

- 3) You may also use the *SEARCH BUTTONS* (17) to set a cue point. While a disc is in PAUSE or CUE mode, use the *SEARCH BUTTONS* (17) to scan through a track to find your desired starting point. Once you have found your desired position press the *PLAY BUTTON* (13) to set your cue point. Pressing the *CUE BUTTON* will now return you to this exact point.

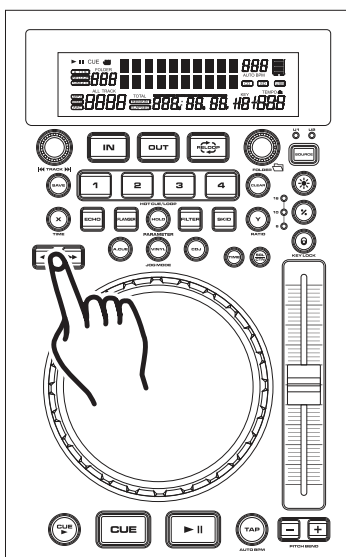
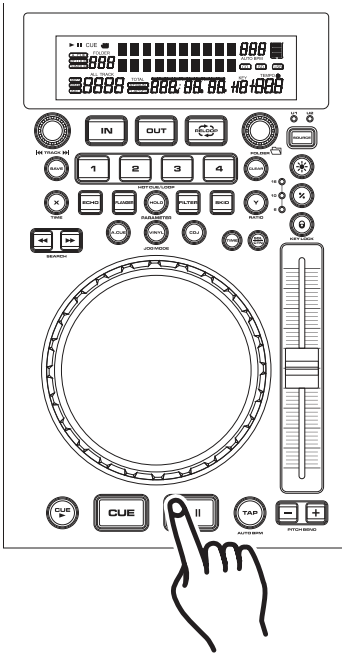

Figure 15

BASIC OPERATIONS (CONT.)

9. CREATING AND PLAYING A SEAMLESS LOOP

A seamless loop is a sound loop that plays continuously without sound interruption. You can use this loop to create dramatic effect in your mixing. This loop has no time limit and you could actually loop the entire length of disc. You create a seamless loop between two continuous points of a disc.



- 1) Press *PLAY/PAUSE BUTTON* (13) to activate playback mode.

Figure 16

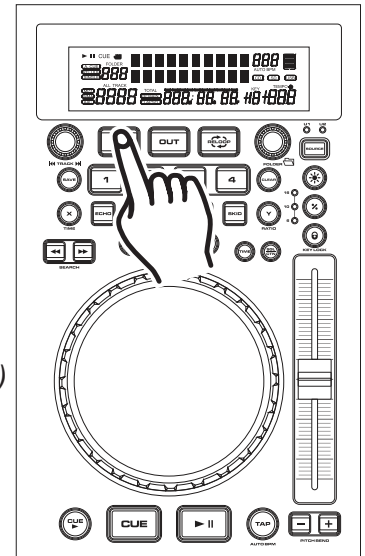

- 2) Press the *IN BUTTON* (22). This will set the starting point of the SEAMLESS LOOP. The *IN BUTTON* (22) LED will light.

Figure 17

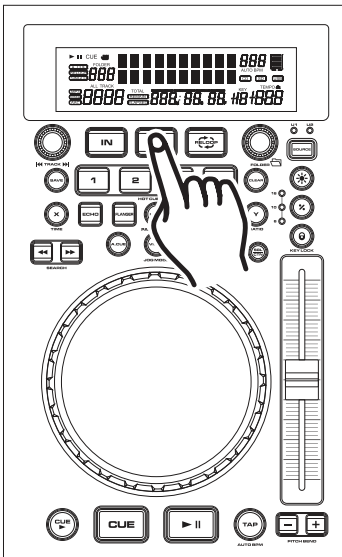

- 3) Press the *OUT BUTTON* (22) to set the ending point for your LOOP (Figure 18). The *IN BUTTON* (22) and *OUT BUTTON* (22) LEDs will immediately begin to flash rapidly, indicating the SEAMLESS LOOP mode has been activated.

VFD LOOP INDICATORS - During a loop, the *RELOOP INDICATOR* (73) will turn on in the *VFD DISPLAY* (23) indicating a loop is active.

Figure 18

EXITING A LOOP - To exit a SEAMLESS LOOP, press the *OUT BUTTON* (22). The *IN BUTTON* (22) and *OUT BUTTON* (22) LEDs will remain lit. Music playback will resume normal play. The *IN BUTTON* (22) and *OUT BUTTON* (22) LEDs will remain lit to remind you that a loop is in memory.

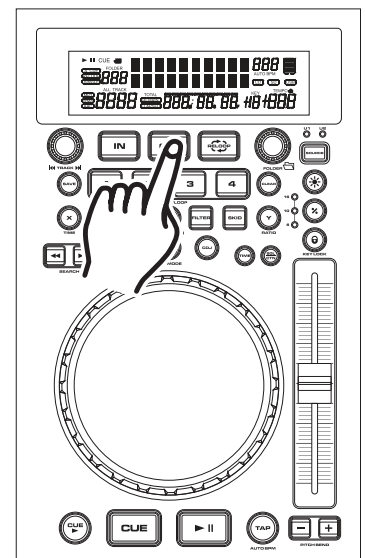
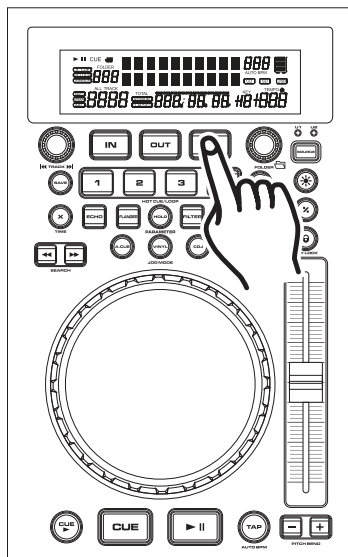

Figure 19

BASIC OPERATIONS (CONT.)



REPLAY LOOP - The *RELOOP* (22) function allows you to return to your stored loop at any time. The *IN BUTTON* (22) and *OUT BUTTON* (22) LEDs will indicate a loop is stored in memory, and may be played at any time. To replay the loop, press the *RELOOP BUTTON* (22). The *IN BUTTON* (22) and *OUT BUTTON* (22) LEDs will again begin to flash indicating SEAMLESS LOOP mode has been activated and your loop will immediately begin to play.

Figure 20

EDITING A LOOP:

Please Note: Only the end point of the loop may be edited. You may make your loop shorter or longer. Before you can edit your seamless loop you obviously must first have created a seamless loop to edit. If you haven't created a SEAMLESS LOOP, follow the instructions in step 9 to create a loop. If a SEAMLESS LOOP has already been created, press the *RELOOP BUTTON* (22) to activate your SEAMLESS LOOP (Figure 20) if it is not already activated. To edit your seamless loop's ending point:

1) Press the *OUT BUTTON* (22) to return to normal play (Figure 19). This will disengage the SEAMLESS LOOP mode and allows you to edit the loops ending point.

Press the *OUT BUTTON* (22) again when you reach your new ending point (Figure 19).

- **FOR A SHORTER LOOP:** Press the *OUT BUTTON* (22) at sooner point in the track.
- **FOR LONGER LOOP:** Press the *OUT BUTTON* (22) at later point in the track.

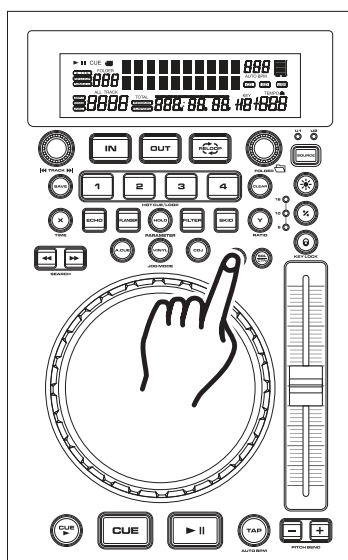

10. CHANGING THE TIME DISPLAY (66)/TIME BAR (67):

During normal playback, pressing the *TIME BUTTON* (18), will change the time display information (66) in the *VFD* (23). The following is a break down of the time settings and their definitions:

- 1) *REMAIN* (68) - This details the time in the *VFD* (23) as the current tracks' remaining running time.
- 2) *ELAPSED* (68) - This details the time in the *VFD* (23) as the current tracks' elapsed running time.

Figure 21

TIME BAR INDICATOR - Details the time defined in the *TIME METER* (66) as a visual bar icon. As with the *TIME METER* (66) this bar is also dependent on the selected time function [*REMAIN OR ELAPSED*]. This bar will begin to flash when a track is ending regardless of which time function you are in. Use the flashing bar as a visual reminder that a track is ending.

BASIC OPERATIONS (CONT.)

10. Bank Buttons (19):

These buttons are used to store your cue points and loops. Only a sample or a cue point can be stored into each of these four banks. When a sample is stored in of the banks you may use the sample starting point as a cue point. The *BANK BUTTONS (19)* instantly recall and play any of your stored cue points or loops. If the unit is not in playback mode, pressing and holding any of the *BANK BUTTONS (19)* that stores a loop or cue point, will immediately begin to playback from that point until that *BANK BUTTON (19)* is released.

To store a loop:

1) Create a loop (see creating a seamless loop on page 23 and 24).

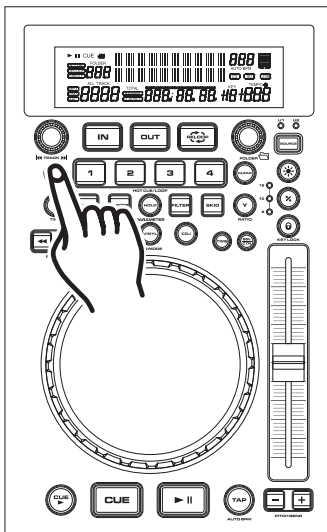

Figure 22

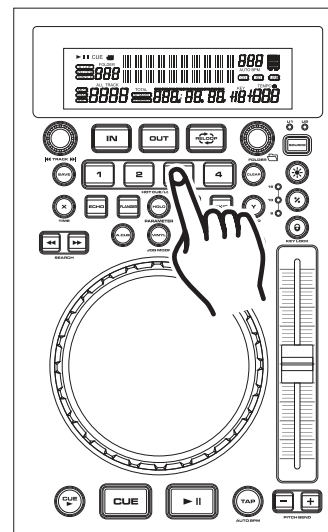

Figure 23

2) Press the *SAVE BUTTON (20)*. The *SAVE BUTTON (20)* LED will glow indicating memory is ready to be stored.

3) Select one of the four *BANK BUTTONS (19)* you wish to store your loop in and press that button.

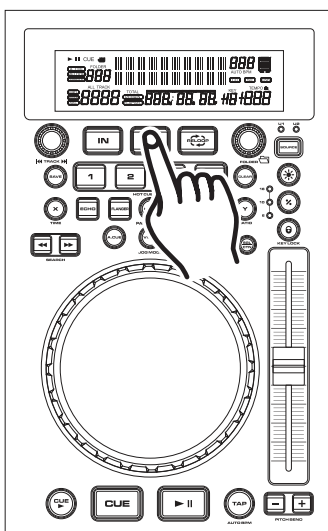

Figure 24

- 4) The *SAVE BUTTON (20)* LED will turn off, when your cue point or loop is locked into memory.
- 5) At this point your loop has been stored into memory. The loop you created will remain playing until the *OUT BUTTON (22)* is pressed (Figure 24).
- 6) Your cue point or loop can now be recalled at any time even when the unit is in PAUSE MODE. To recall, press the corresponding *BANK BUTTON (19)*.

PITCH ADJUSTMENTS

PITCH ADJUSTMENTS:

You can activate the *PITCH SLIDER (10)* by pressing the *PITCH ON/OFF BUTTON (4)*. When the button LED is lit, the *PITCH SLIDER (10)* is active and the pitch can be adjusted. When the button LED is not lit *PITCH SLIDER (10)* is not active. The different pitch adjustments allow a track's or a loop's playback speed to be manipulated. This speed manipulation is commonly used to beat match between two or more music sources such as a turntable or CD player. The playback speed may be increased or decreased by a factor of +/-16. The next section details the different pitch manipulation schemes.

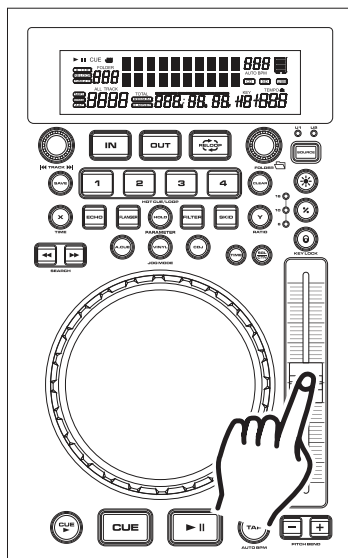

1. PITCH SLIDER (10):

This function will increase or decrease the tracks playback speed or "PITCH." The maximum pitch percentage manipulation in this function is +/-16%. The *PITCH SLIDER (10)* is used to decrease or increase the playback pitch. If the slider is moved up (towards the top of the unit) the pitch will decrease, if the slider is moved down (towards the bottom of the unit) the pitch will increase. The *PITCH SLIDER* adjustment can be changed to range from +/-8%, +/-10%, or +/-16% (See changing "PITCH SLIDER PERCENTAGE RANGE" on the next page). This pitch adjustments will effect normal playback and loops only when the *PITCH ON/OFF BUTTON (4)* is turned on.

Figure 25

Activating the PITCH SLIDER (10): To activate the *PITCH SLIDER* you must activate the pitch adjustment. Press the *PITCH ON/OFF BUTTON (4)* to activate the pitch adjustment. The *ON/OFF BUTTON (4)* LED will glow when the function is activated. If the pitch function is not activated the *PITCH SLIDER* will not function.

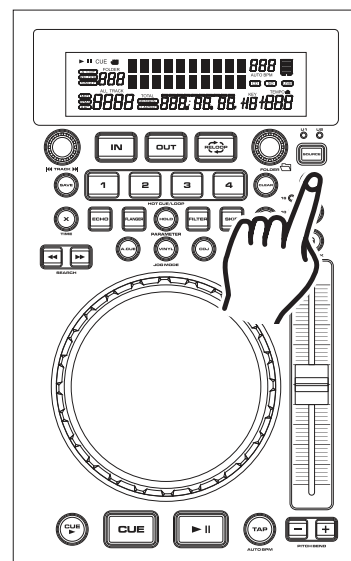

Figure 26

Using the PITCH SLIDER (10): Be sure the pitch function has been activated as described above. To use the *PITCH SLIDER* slide it up to decrease the pitch and down to increase it.

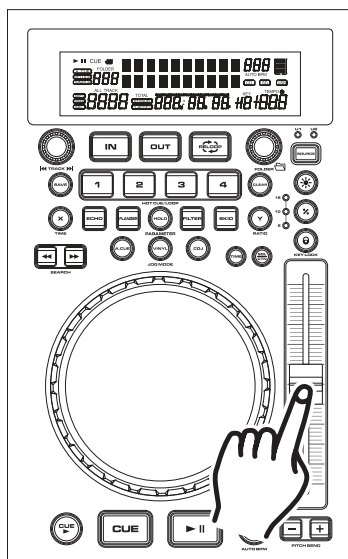

Figure 27

PITCH ADJUSTMENTS

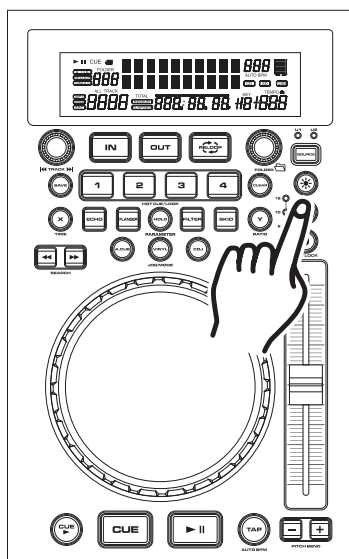

Figure 28

Adjusting the PITCH SLIDER'S RANGE (5): You may change the PITCH SLIDER'S (10) operating range at any time. To change the operating range be sure the pitch function is turned on, see figure 33. The pitch percentage can be changed between +/-6%, +/-10%, and +/-16%. 6% will allow the least amount of pitch manipulation and 16% will allow the most amount of pitch manipulation. To adjust the different ranges, press the PITCH ON/OFF BUTTON (4) and tap on the PITCH RANGE BUTTON (5) until your desired value is reached, see figure 28.

2. PITCH BENDING:

Unlike the PITCH SLIDER (10) adjustment this function will momentarily increase or decrease a tracks speed during playback. There are two ways to operate this function with the (-) & (+) PITCH BEND BUTTONS (11) or with the JOG WHEEL (16). The maximum pitch bend percentage allowed is +/- 16%. The pitch bend function will work in conjunction with the PITCH SLIDER (10) pitch setting. For example, if the PITCH SLIDER (10) is set to a 2% pitch gain the pitch bending process will begin at 2% and will continue to the maximum of +/- 16%.

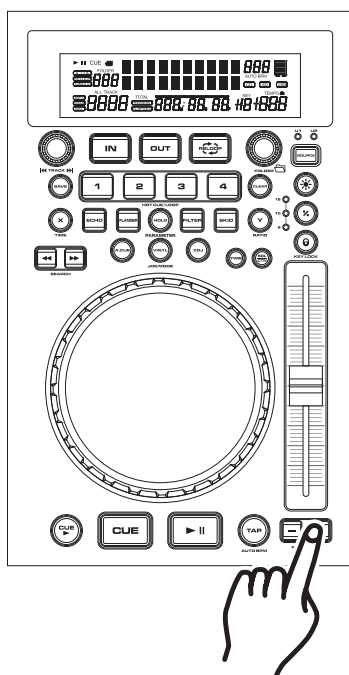

Figure 30

Holding down or tapping on the (+) PITCH BEND BUTTON (11) will provide a speed bump in the playback pitch.

Holding down or tapping on the (-) PITCH BEND BUTTON (11) will provide a slow down in the playback pitch.

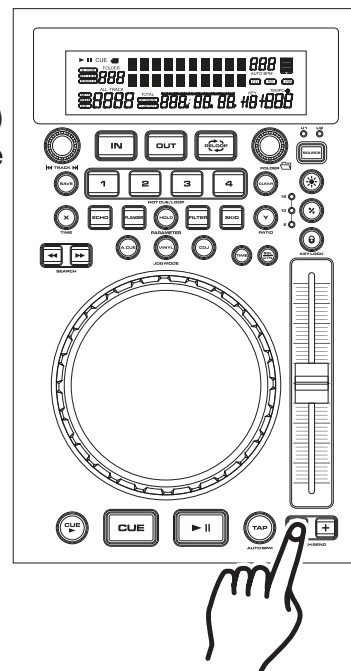

Figure 29

PITCH BEND BUTTONS (11):

The (+) PITCH BEND BUTTON (11) will increase track playback speed and the (-) PITCH BEND BUTTON (11) will decrease track playback speed. The extent to which the speed changes is proportionate to the amount of time the button is pressed. For example, if the (+) PITCH BEND BUTTON (11) is held down continuously as in figure 30, the audio speed will increase and will continue to increase until it reaches a maximum of 16% speed gain. When you release the (+) PITCH BEND BUTTON (11) the audio speed will automatically return to its previous set speed.

PITCH ADJUSTMENTS

3. JOG WHEEL (16):

The *JOG WHEEL* will temporarily bend the pitch if a track is in playback mode. Rotating the wheel in a clockwise direction will increase your track pitch and rotating the wheel in a counter-clockwise direction will slow your track pitch. The speed you rotate the *JOG WHEEL* will determine pitch bend percentage (%). For example, if the *JOG WHEEL* is continuously turned in a counter-clockwise direction the playback speed will steadily decrease and will continue to decrease until playback reaches a maximum of -100% and playback stops entirely. When you stop turning the *JOG WHEEL* the disc speed will automatically return to its previous set speed.

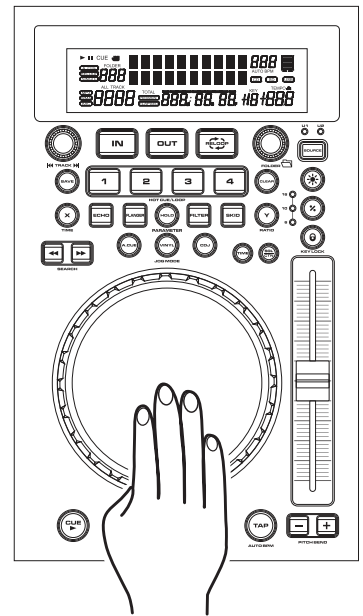
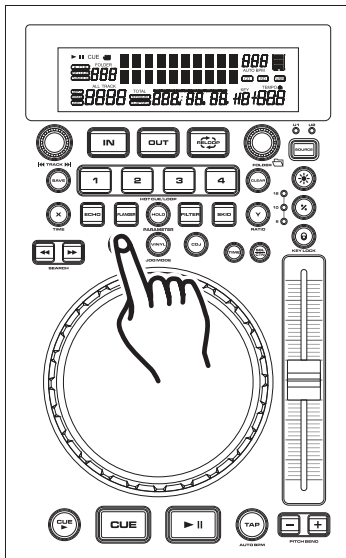

Figure 31

JOG WHEEL FUNCTIONS

JOG WHEEL TOUCH SENSITIVITY: The platter of the jog wheel is touch sensitive allowing certain play and cue commands, as well the scratch effect, to be controlled by touching or tapping on the touch sensitive jog wheel.

ADJUSTING JOG WHEEL TOUCH SENSITIVITY: The degree of sensitivity can be adjusted to make it more or less sensitive. Press and hold the *FOLDER KNOB* (1) to enter the INTERNAL MENU. Turn the *FOLDER KNOB* (1) clockwise till SENSITIVITY is displayed. Turn the *TRACK KNOB* (21) to find your desired sensitivity, the range of sensitivity is from -20 to +20. The *VFD* (23) will display the degree of sensitivity. When you have found your desired level press the *FOLDER KNOB* (1) to confirm and exit.



A.CUE: Before you can use the *JOG WHEEL* (16) to control the play and cue commands you must first activate the A.Cue Mode. To activate press the *A.CUE BUTTON* (9).

Figure 32

IN PLAYBACK MODE: While in play mode and with the A. Cue Mode active, the *JOG WHEEL* (16) can be used to return the unit to last cue point. Simply touch the *JOG WHEEL* (16) and unit will immediately return to the last set cue point and playback without music interruption.

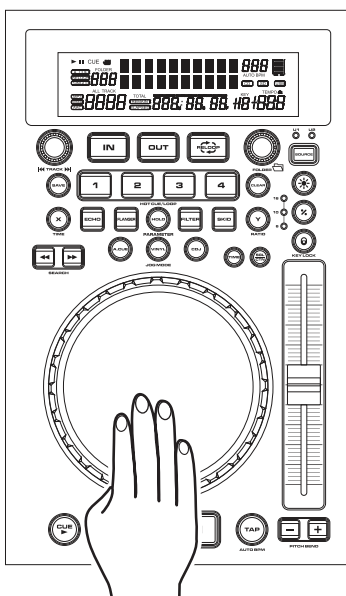
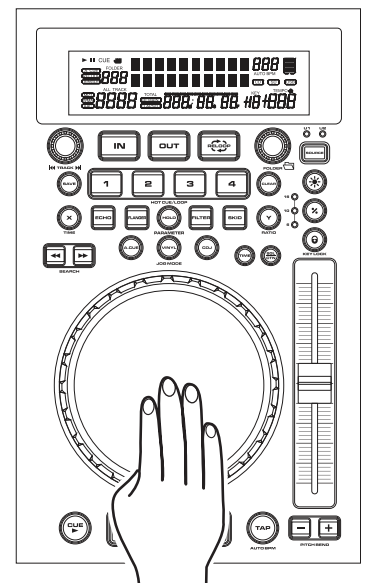

Figure 33

IN CUE MODE: While in cue or pause mode and with the A. Cue Mode active, touching or tapping on the *JOG WHEEL* (16) can be used to start playback. The unit will continue to playback until the *JOG WHEEL* (16) is released. Once the *JOG WHEEL* (16) is released the unit will return to the last cue point.



JOG WHEEL FUNCTIONS

VINYL MODE & CDJ MODE: The Vinyl Mode simulates real time turntable scratching. Once the Vinyl Mode has been activated the *JOG WHEEL (16)* may be used in the same fashion a turntable platter is used. Use the *JOG WHEEL (16)* to simulate the scratch motion on a turntable platter and to manipulate playback. The CDJ Mode is used for pitch bending and frame search.

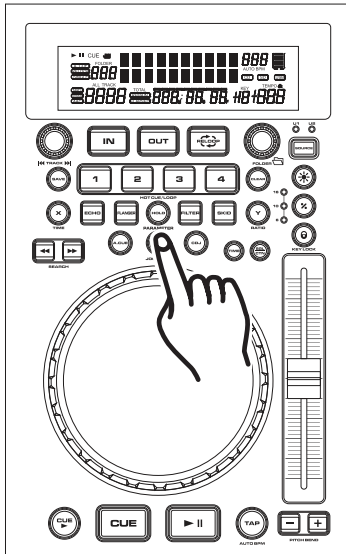

VINYL MODE: Before you can use the *JOG WHEEL (16)* to simulate real time turntable scratching you must activate the Vinyl Mode. To activate press the *VINYL BUTTON (9)*.

PLAYBACK MODE: While in play mode and with the Vinyl Mode active, the *JOG WHEEL (16)* is used to apply the scratch effect to the audio source. Rotate the *JOG WHEEL (16)* clockwise & counter-clockwise simulate turntable scratching.

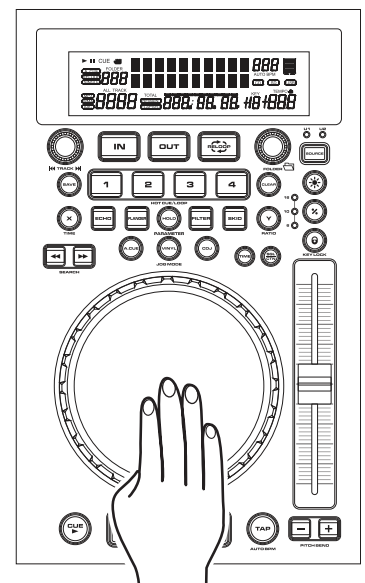

Figure 36

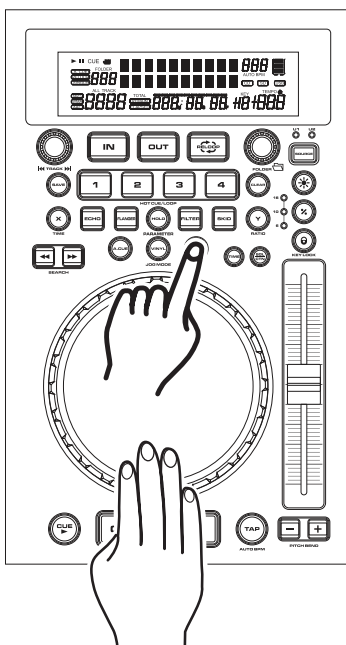

Figure 37

CDJ MODE: While in cue or pause mode and with the CDJ Mode active, rotating *JOG WHEEL (16)* can be used frame search.

While in play mode and with the CDJ Mode active, the *JOG WHEEL (16)* can be used to pitch bend. Rotating clockwise will speed it up to 100%, while rotating counter-clockwise will slow it down. Remember, this is a momentary function. When you stop rotating the wheel, the BPM's will automatically return to *PITCH SLIDERS (10)* selected pitch.

BUILT-IN EFFECTS

The VERSADECK comes with four built in effects. These effects can be used one at a time or you may choose to overlap the effects and use up to four at a time. The Built-in effects include Echo, Filter, Skid, and Flanger. You can choose to use the effects with their default parameters or you may choose to customize each effect by changing the parameters. The parameter values for all the effects will range. Some effects will have more adjustable parameters than others. The parameters have two adjustable values, PR (Parameter Ratio) and PT (Parameter Time). **All parameters will be reset to there default values when power is shut off!**

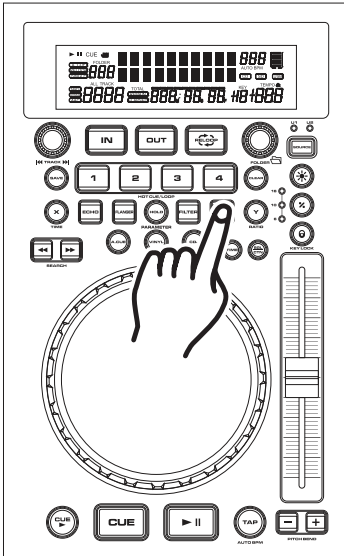

Figure 38

SKID EFFECT: The Skid effect simulates the stop and start time of a turntable platter. The Skid Effect has two adjustable parameters, Parameter Time (PT) and Parameter Ratio (PR). The PT will adjust the Start Time and the PR will adjust the Stop Time (see "Parameters" on page 32).

FILTER EFFECT: The Filter effect tweaks the original sound to add different tonal definition. The Filter Effect has two adjustable parameters, Parameter Time (PT) and Parameter Ratio (PR). The PT will adjust the time it takes for the filter to sweep the frequency band, and the PR will adjust the Frequency Range; 0 is the low end, 155 mid range, & 255 high end frequencies. (see "Parameters" on page 32).

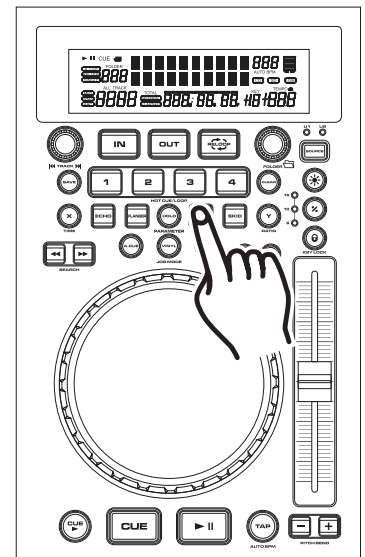

Figure 39

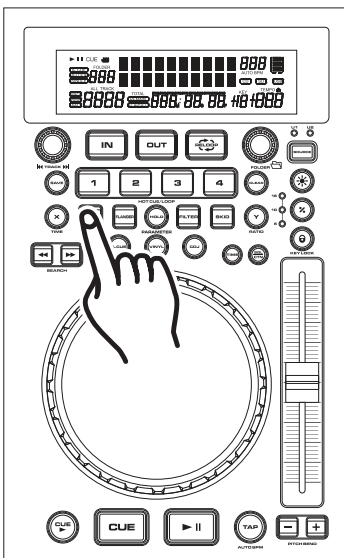

Figure 40

ECHO EFFECT: The Echo effect adds an echo to your output signal. The Echo effect has two adjustable parameters, Parameter Time (PT) and Parameter Ratio (PR). The PT will adjust the time range and the PR will adjust the dry to wet ratio; 000 (Dry)-255 (Wet) (see "Parameters" on page 32).

BUILT-IN EFFECTS

FLANGER EFFECT: The Flanger effect distorts the output signal and creates an effect similar to frequencies phasing in and out of each other. The FLANGER Effect has two adjustable parameters, Parameter Time (PT) and Parameter Ratio (PR). The PT will adjust the Time Range and the PR will adjust the Frequency Range (see "Parameters" in the next section).

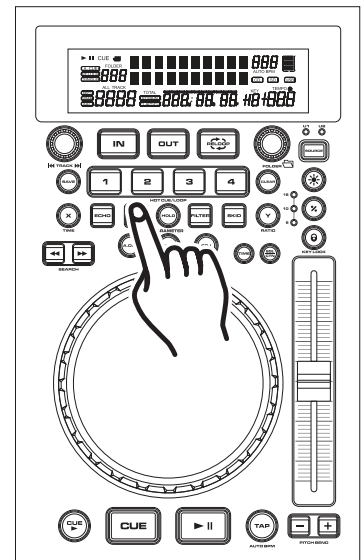

Figure 41

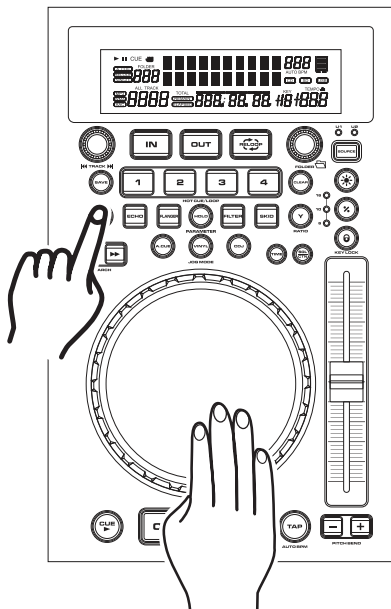

Figure 42

PARAMETERS:

All the effects have adjustable parameters. The parameters change the way the effects will react. To adjust the parameter values for any of the effects, press the *PARAMETER BUTTON (18)* you wish to adjust, then use the *JOG WHEEL (16)* to adjust the Parameter settings. The *JOG WHEEL (16)* must be in CDJ mode to make the adjustments. When the parameter value is adjusted the VFD display will indicate the parameter adjustment. All effects have two adjustable parameters; X *PARAMETER TIME* and Y *PARAMETER RATIO*. Use these parameters to customize the effects to your liking.

HOLD BUTTON: Use the *HOLD BUTTON (18)* to lock your parameters. If the hold button is not activated any changes to your parameters will be momentary. To activate the hold function press the *HOLD BUTTON (18)* as in figure 43. When the hold function becomes activated, the hold button LED will glow.

The *HOLD BUTTON (18)* is also used to lock up the entire player so that there are no accidental mistakes. The mixer functions will not be locked so that adjustments can be made to the audio levels. Press the *HOLD BUTTON (18)* for at least 3 secs. to lock the player. LOCK will appear quickly in the VFD, and the *HOLD BUTTON (18)* LED will flash. To unlock the player press the *HOLD BUTTON (18)* for at least 3 secs. or until UNLOCK is displayed in the VFD.

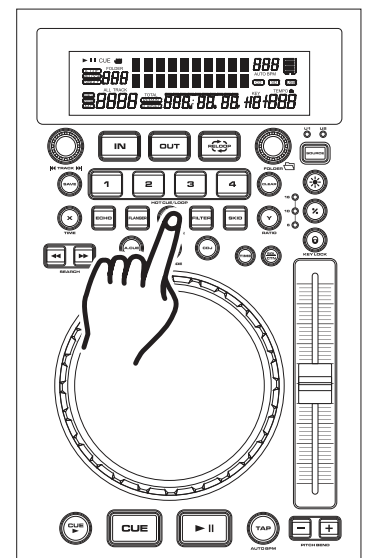

Figure 43

PLAYLIST OPERATION

Playlist Operation:

1. Press and hold the *FOLDER KNOB (1)* for 3 sec. to enter the internal menu. Turn the knob until "PLAYLIST" is displayed.
2. Turn *TRACK KNOB (21)* to scroll through "Normal/Title/Artist/Album/Genre". Press the *FOLDER KNOB (1)* to save your desired selection and exit. The database should adjust to your setting.

Example: "Artist" is selected, all artists will be in alphabetical order

Pushing and turning the FOLDER KNOB will take you to the next letter; so if you are going through the C artists, holding and turning the FOLDER KNOB will skip you up to the D artists. You can turn the FOLDER KNOB, or push the FOLDER KNOB in and turn the JOG WHEEL to jump to the next artist.

You can skip through tracks by turning the TRACK KNOB, or by pressing the TRACK KNOB and turning the JOG WHEEL as well.

RELAY (FLIP-FLOP™)

RELAY MODE

This feature is a kind of "auto pilot". When you are using the VERSADECK system, you can have one player begin playback when the other ends. You can RELAY single tracks, the entire folder, or a combination of the two.

To RELAY single tracks:

- 1) Set the mixer's crossfader to the center position, and press the *RELAY BUTTON (34)*.
- 2) Set the two players to playback in single mode, *SINGLE (72)* should be indicated in the *VFD (23)*.
- 3) Load your two players with audio discs.
- 4) After they have both cued, press the *PLAY/PAUSE BUTTON (13)* on one player to begin playback.
- 5) After the first player's single track has ended the second player's track will immediately begin playback.
- 6) FLIP-FLOP™ will continue until you stop it or power is interrupted.

To Flip-Flop entire folders:

Be sure your players are both in continuous play mode, make sure *SINGLE MODE (72)* does not appear in the *VFDS (23)* of both players. Follow all directions for single track RELAY above. When one player's folder ends the other player will immediately begin playback.

Note: You may combine RELAY single and continuously playback modes by selecting either single or continuous playback on your units.

DATABASE BUILDER

Minimum Hardware Requirements:

CPU: Intel Pentium 4 1GHz processor or above, Intel Centrino Mobile Technology 1.6GHz

RAM: 512MB RAM

DISC SPACE: 100MB of free disc space needed

OS: Microsoft Windows XP SP3, Vista SP2 or Mac OS X 10.4

The device includes a database management software that enables you to search for your files by Title, Artist, Album, and Genre.

Installation:

Refer to the following figures for installing database management software on your computer.



Step 1: Click Next >

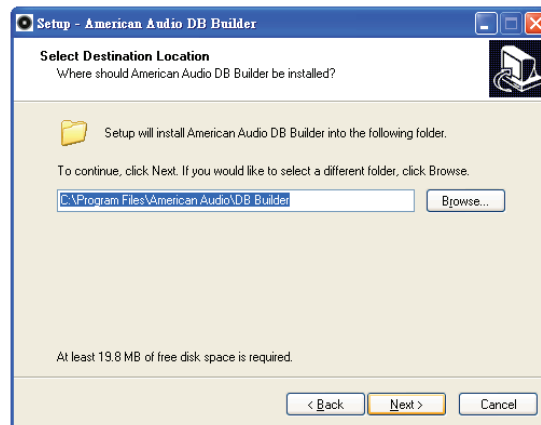

Step 2: Click Next >

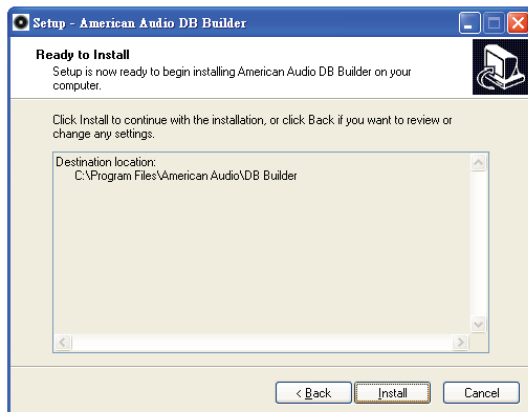

Step 3: Click Install

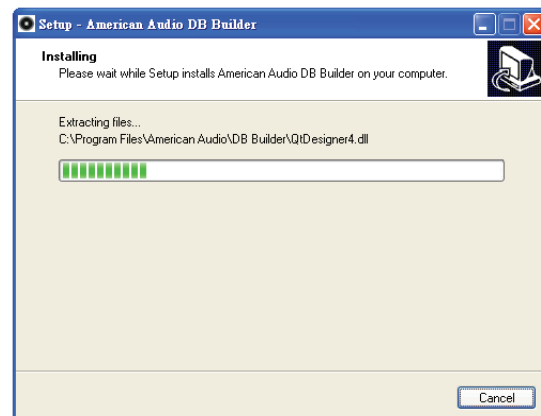

Step 4: Processing

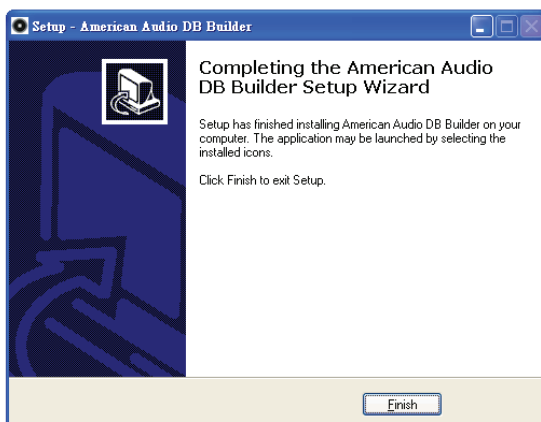

Step 5: Click Finish

The database builder will scan your USB hard drive and create database files so that you may locate the files in your music library to your liking.

DATABASE BUILDER (FOR WINDOWS XP)

Scan and Create:

Refer to the following figures to process scanning and creating a database.

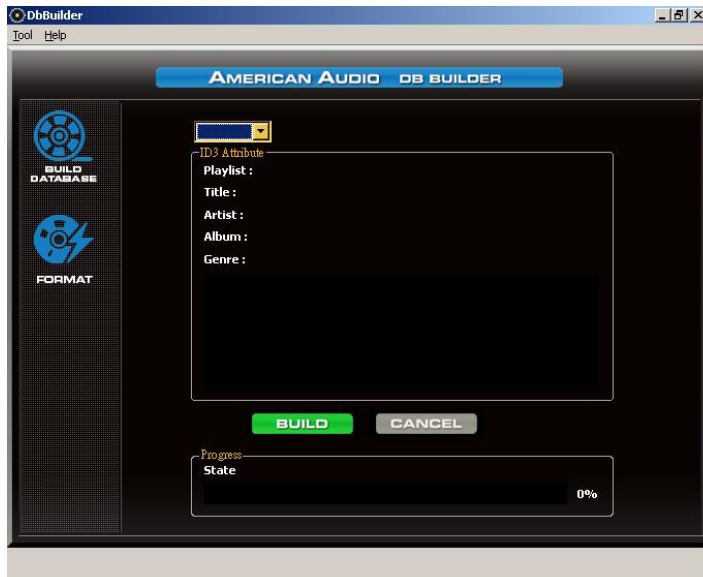

Select your desired USB hard drive and click "Build".

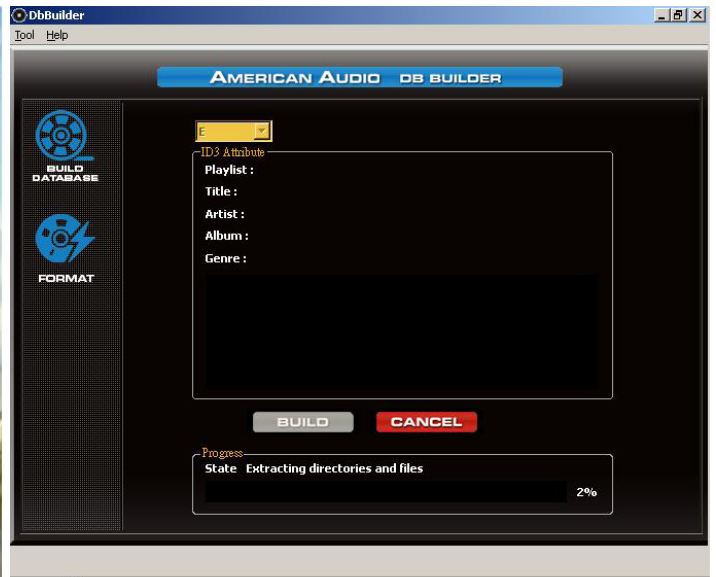

Processing

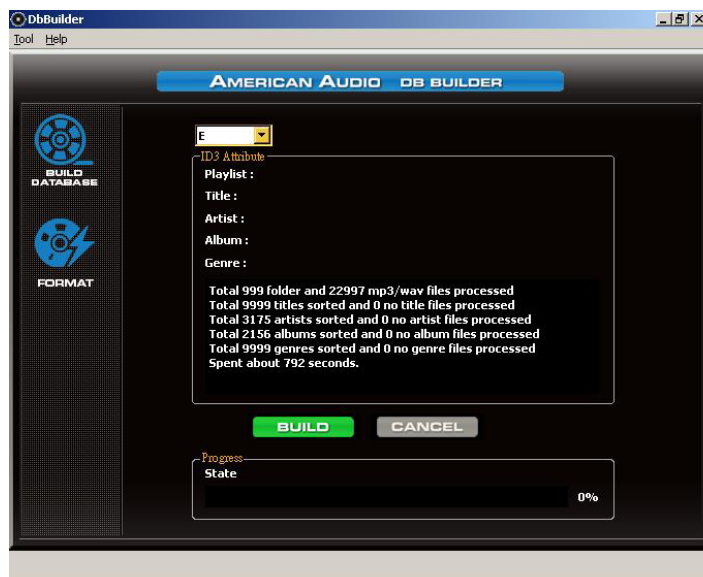

Complete

NOTE: Please re-create the database builder whenever you change the contents of your USB device.

DATABASE BUILDER

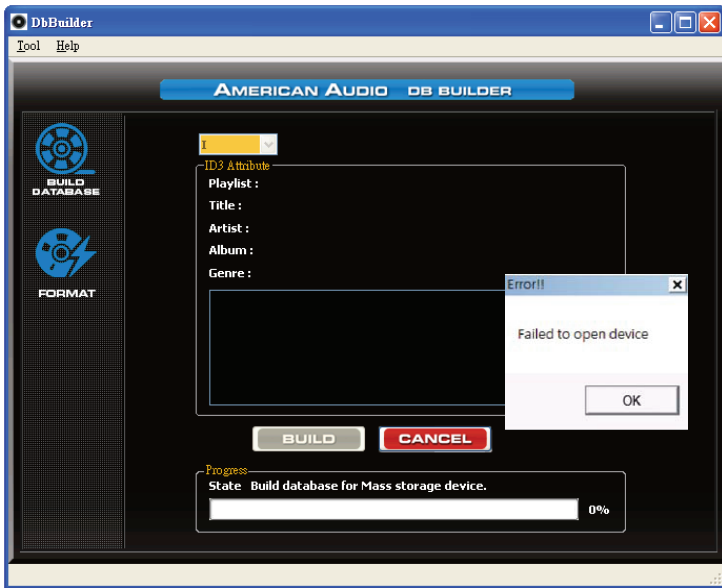

Errors:



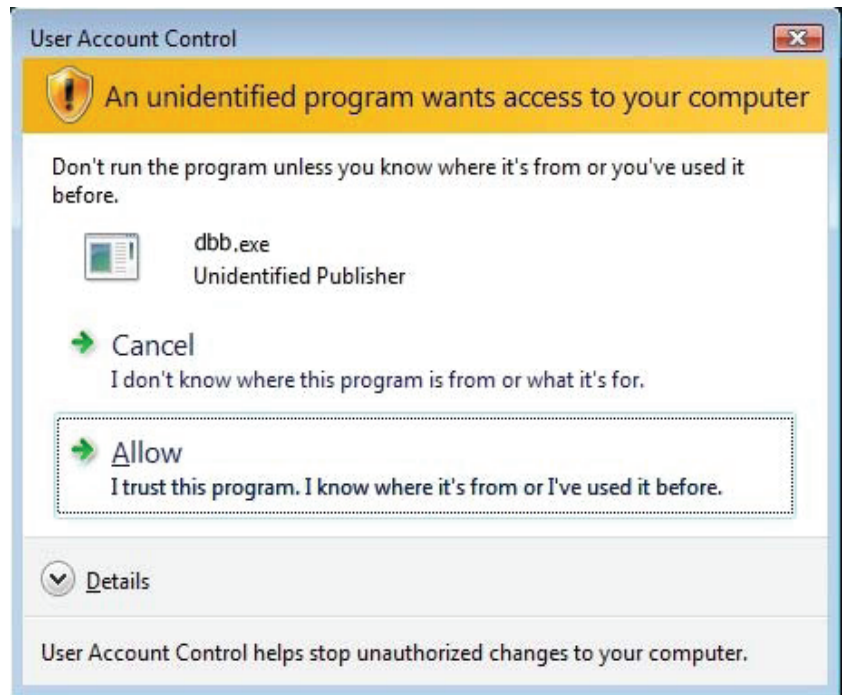

1. Failed to Open Device: Your drive is a non supported format.
2. File Error: This is due to MP3 file not have a identified ID3 tag.

Windows 7/Vista may warn you according to your security settings. Select Allow if you wish to install the database builder program.



MIDI MAP

Note: By default Player 1 is set to MIDI Channel 1, the Mixer, Mic, VR, and Headphone controls are set to MIDI Channel 2, and Player 2 is set to MIDI Channel 3.

FUNCTION	Type	FUNCTION CODE (DECK A)	NOTE	SHIFT (Hold TAP)	FUNCTION CODE (DECK B)	NOTE	SHIFT (Hold TAP)	FUNCTION CODE (CENTER DECK)	NOTE	SHIFT (Hold TAP)	ACTION
 FOLDER	SW/ENC	05/17		44/56	05/27		44/66				7FH_ON 00H_OFF
 TRACK	SW/ENC	01/16		40/55	01/26		40/65				7FH_ON 00H_OFF
IN	SW/LED	02/02	D-1	41	02/02	D-1	41				7FH_ON 00H_OFF
OUT	SW/LED	03/03	D#-1	42	03/03	D#-1	42				7FH_ON 00H_OFF
 RELOOP	SW/LED	04/04	E-1	43	04/04	E-1	43				7FH_ON 00H_OFF
SOURCE SELECT/U1	SW/LED	06/06	F#-1	45	06/06	F#-1	45				7FH_ON 00H_OFF
SAVE	SW/LED	07/07	G-1	46	07/07	G-1	46				7FH_ON 00H_OFF
1	SW/LED (RED)	08/08	G#-1	47	08/08	G#-1	47				1~31: LED ON, 32:BLINK 00H_OFF
1	LED (GREEN)	08/08	G#-1	47	08/08	G#-1	47				33~63: LED ON, 64:BLINK 00H_OFF
2	SW/LED (RED)	09/09	A-1	48	09/09	A-1	48				1~31: LED ON, 32:BLINK 00H_OFF
2	LED (GREEN)	09/09	A-1	48	09/09	A-1	48				33~63: LED ON, 64:BLINK 00H_OFF
3	SW/LED (RED)	0A/0A	A#-1	49	0A/0A	A#-1	49				1~31: LED ON, 32:BLINK 00H_OFF
3	LED (GREEN)	0A/0A	A#-1	49	0A/0A	A#-1	49				33~63: LED ON, 64:BLINK 00H_OFF
4	SW/LED (RED)	0B/0B	B-1	4A	0B/0B	B-1	4A				1~31: LED ON, 32:BLINK 00H_OFF
4	LED (GREEN)	0B/0B	B-1	4A	0B/0B	B-1	4A				33~63: LED ON, 64:BLINK 00H_OFF
CLEAR	SW/LED	0C/0C	C0	4B	0C/0C	C0	4B				7FH_ON 00H_OFF
	SW/LED	0D/0D	C#0	4C	0D/0D	C#0	4C				7FH_ON 00H_OFF
Time X	SW/LED	0E/0E	D0	4D	0E/0E	D0	4D				7FH_ON 00H_OFF
ECHO	SW/LED	0F/0F	D#0	4E	0F/0F	D#0	4E				7FH_ON 00H_OFF
FLANGER	SW/LED	10/10	E0	4F	10/10	E0	4F				7FH_ON 00H_OFF
HOLD	SW/LED	11/11	F0	50	11/11	F0	50				7FH_ON 00H_OFF
FILTER	SW/LED	12/12	F#0	51	12/12	F#0	51				7FH_ON 00H_OFF
SKID	SW/LED	13/13	G0	52	13/13	G0	52				7FH_ON 00H_OFF
RATIO Y	SW/LED	14/14	G#0	53	14/14	G#0	53				7FH_ON 00H_OFF

MIDI MAP

%/ 16	SW/LED	15/15	A0	54	15/15	A0	54				7FH_ON 00H_OFF
◀	SW	16		55	16		55				7FH_ON 00H_OFF
▶	SW	17		56	17		56				7FH_ON 00H_OFF
A.Cue scratch	SW/LED	18/18	C1	57	18/18	C1	57				7FH_ON 00H_OFF
VINYL	SW/LED	19/19	C#1	58	19/19	C#1	58				7FH_ON 00H_OFF
CDJ	SW/LED	1A/1A	D1	59	1A/1A	D1	59				7FH_ON 00H_OFF
Time	SW	1B		5A	1B	D-1	5A				7FH_ON 00H_OFF
SGL/CTN	SW	1C		5B	1C		5B				7FH_ON 00H_OFF
6	SW/LED	1D/1D	F1	5C	1D/1D	F1	5C				7FH_ON 00H_OFF
JOG	SW/ENC	27/18		66/57	27/28		66/67				7FH_ON 00H_OFF
CUE ▶	SW	1E		5D	1E		5D				7FH_ON 00H_OFF
CUE	SW/LED	1F/1F	G1	5E	1F/1F	G1	5E				7FH_ON 00H_OFF
▶	SW/LED	20/20	G#1	5F	20/20	G#1	5F				7FH_ON 00H_OFF
TAP	SW/LED	21/21	A1		21/21	A1					7FH_ON 00H_OFF
—	SW	22		61	22		61				7FH_ON 00H_OFF
+	SW	23		62	23		62				7FH_ON 00H_OFF
Pitch Silder	VR/CENT ER	PITCH BEND/28		67	PITCH BEND/28		67				7FH_ON 00H_OFF
GAIN	VR	11		50	21		60				VR:00~7F
HIGH	VR/SW/C ENTER/L ED	12/24/29/24	C2	51/63/68	22/24/29/24	C2	61/63/68				VR:00~7F
MID	VR/SW/C ENTER/L ED	13/25/2A/25	C#2	52/64/69	23/25/2A/25	C#2	62/64/69				VR:00~7F
LOW	VR/SW/C ENTER/L ED	14/26/2B/26	D2	53/65/6A	24/26/2B/26	D2	63/65/6 A				VR:00~7F
Channel Fader	VR	10		4F	20		5F				VR:00~7F
U2	LED	2C	G#2		2C	G#2					7FH_ON 00H_OFF
10	LED	2D	A2		2D	A2					7FH_ON 00H_OFF
6	LED	2E	A#2		2E	A#2					7FH_ON 00H_OFF
LEVEL METER LED	LEVEL METER LED	1			1						00H~7FH_ *
RELAY	SW/LED							37/37	G3	76	7FH_ON 00H_OFF
MASTER METER	SW/LED							38/38	G#3	77	7FH_ON 00H_OFF
MASTER	VR							31		70	VR:00~7F
BOOTH	VR							32		71	VR:00~7F
Cross Fader	VR/SW/ SW/CENT ER							30/08/ 09/0A		6F/47/ 48/49	VR:00~7F
MIC1 LEVEL	VR							35		74	VR:00~7F
MIC2 LEVEL	VR							36		75	VR:00~7F

MIDI MAP

CUE PAN SLIDER	VR							34		73	VR:00~7F
CUE PAN LEVEL	VR							33		72	VR:00~7F
Fader Start ON(L)	SW							1		40	7FH_ON 00H_OFF
Fader Start OFF(L)	SW							2		41	7FH_ON 00H_OFF
Fader Start ON(R)	SW							3		42	7FH_ON 00H_OFF
Fader Start OFF(R)	SW							4		43	7FH_ON 00H_OFF
C.F CURVE (L)	SW							7		46	7FH_ON 00H_OFF
C.F CURVE (CENTER)	SW							6		45	7FH_ON 00H_OFF
C.F CURVE (R)	SW							5		44	7FH_ON 00H_OFF

CC-ABSOLUTE (VR, LEVEL METER LED) TYPE

Control Change messages are sent with status 0xBn, where n is the channel, for the specified CC controller. Thus the controller MIDI ID is indicated with the channel along with the CC number. The value from 0x00 to 0x7F, directly related to the location of the controller.

* LEVEL METER LEDES

00~0B => ALL LEDES OFF

0C~17=>LED(-30) ON

18~23=>LED(-30, -20) ON

24~2F=>LED(-30, -20, -10) ON

30~3B=>LED(-30, -20, -10, -7) ON

3C~47=>LED(-30, -20, -10, -7, -4) ON

48~53=>LED(-30, -20, -10, -7, -4, -2) ON

54~5F=>LED(-30, -20, -10, -7, -4, -2, 0) ON

60~6B=>LED(-30, -20, -10, -7, -4, -2, 0, +2) ON

6C~77=>LED(-30, -20, -10, -7, -4, -2, 0, +2, +4) ON

78~7F=> ALL LEDES ON (-30, -20, -10, -7, -4, -2, 0, +2, +4, +7)

CC-RELATIVE (ENC)TYPE

Control Change messages are status 0xBn, where n is the channel, for the specified CC controller. Thus the controller MIDI ID is indicated with the channel along with the CC number. The value from 0x40 to indicate the change in the controller. This is an offset to 0x40 "one's complement" notation.

A message with data 0x43 indicates a **positive** change of 3.

A messages with data 0x31 indicates a **negative** change of 15.

SWITCH ON/OFF (SW,CENTER TYPE)

These messages are used for switches.

Control Change messages are sent with status 0x9n, SWITCH On and Off value are 0x7F and 0x00, where n is the channel.

LED ON/OFF (LED TYPE)

These messages are used for LED.

Control Change messages are sent with status 0x9n, LED On and Off value are 0x7F and 0x00, where n is the channel.

MIXER SET-UP

Before making or changing connections, switch off the power and disconnect the power cord from the AC outlet.

Note: Quality cables make a big difference in fidelity and punch. Use high-quality audio cables. Do not use excessively long cables. Be sure plugs and jacks are securely fastened. Loose connections cause hum, noise, or intermittence that could damage your speakers.

Connecting to a computer - Support computer operating systems include Windows Vista, Windows XP, and MAC OS X or later.

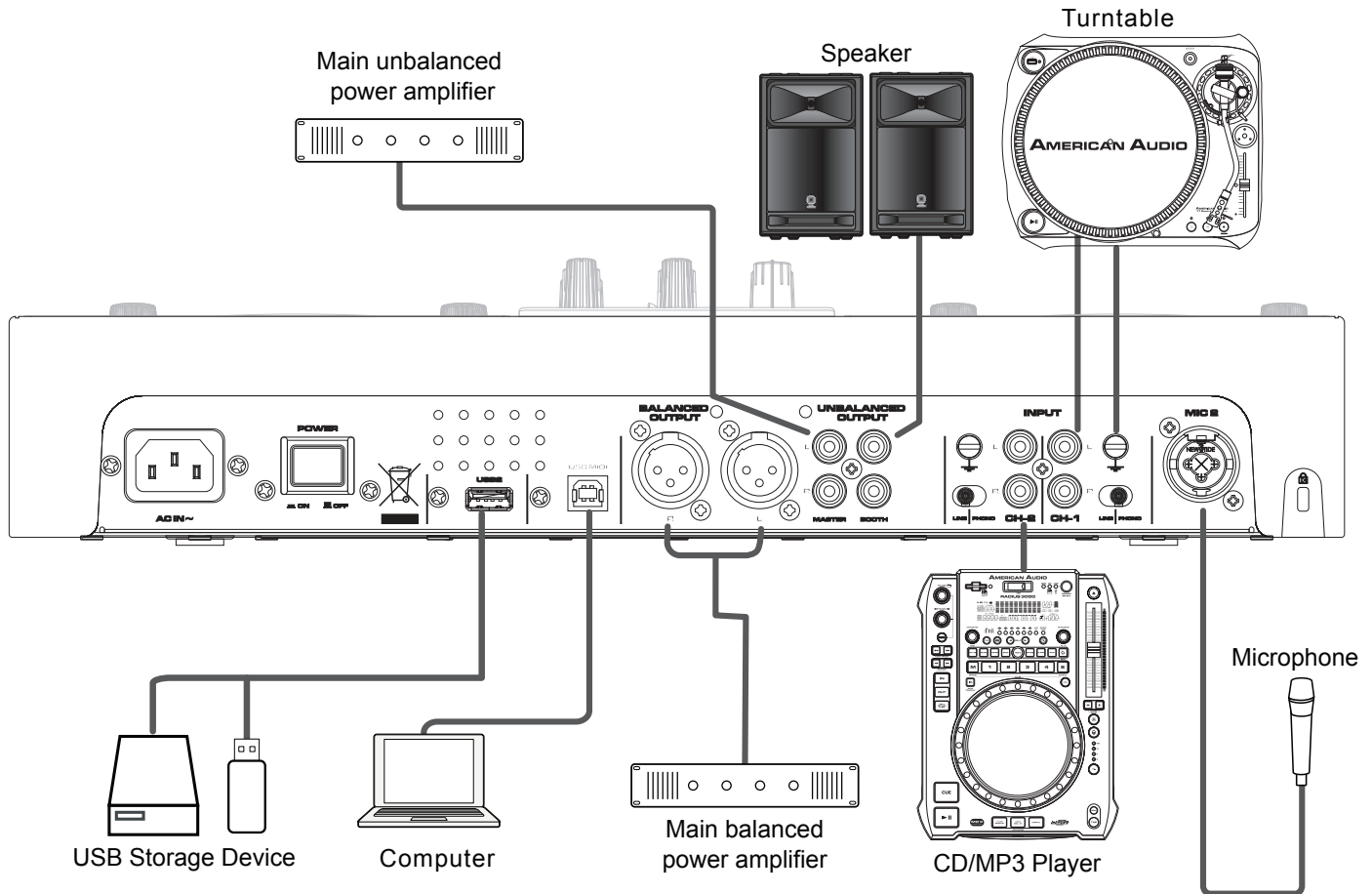

This image details a DJ Set Up consisting of a microphone, CD player, turntable, computer, amps, USB storage device, and speakers. When connecting and using a turntable be sure the *CHANNEL LINE LEVEL SELECTOR SWITCH (47)* that corresponds with turntable connection is in the PHONO position.

MIXER SET-UP

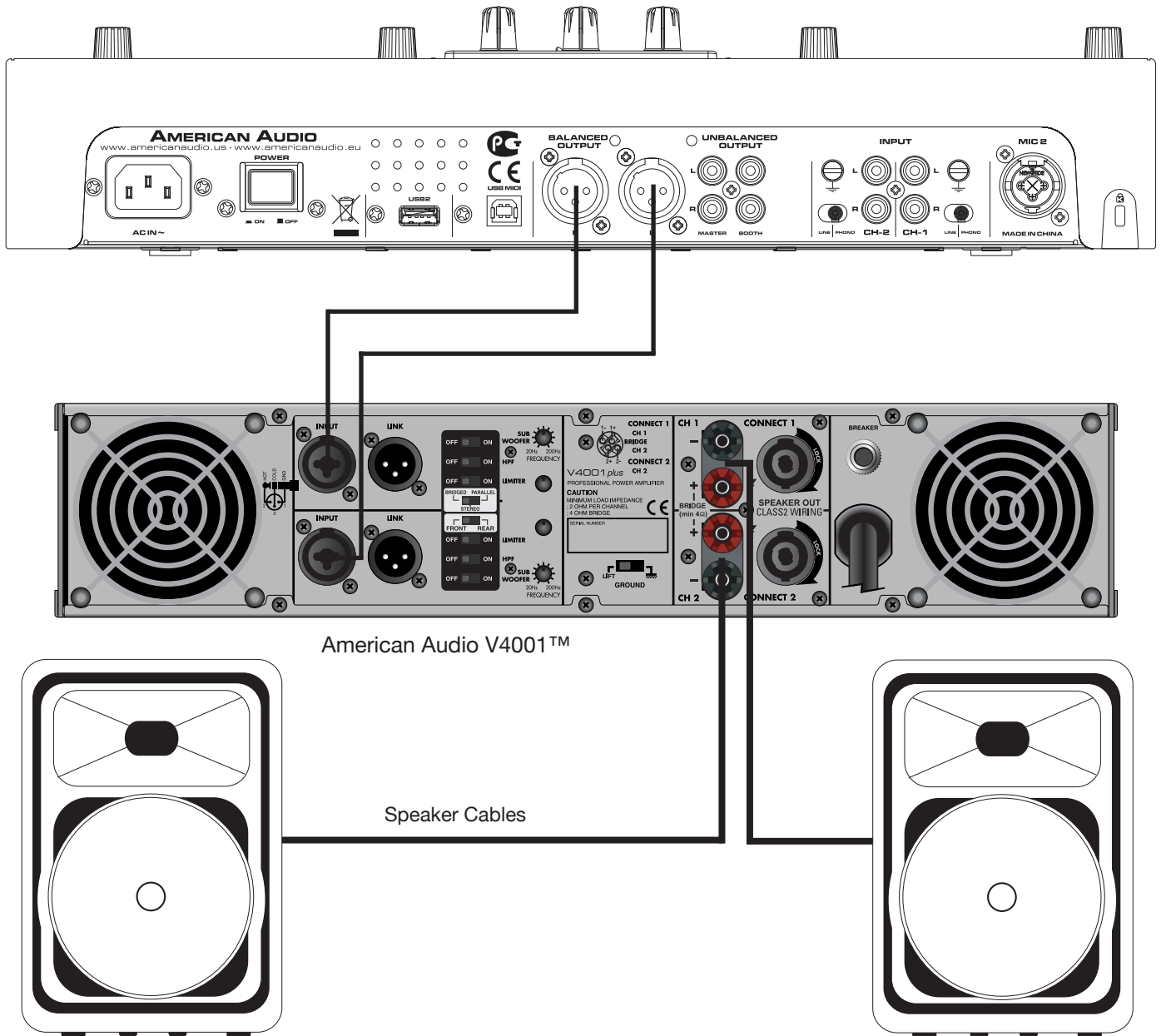

Typical Balanced Output Set-up

This image details a typical stereo output layout. Note the use of the Balanced XLR Jacks on both the mixer and the amplifier. Always use the balanced output jacks whenever possible. The balanced output jacks should always be used for cable runs in excess of 15 feet.

Using the balanced jacks will ensure a clean signal through out the entire audio system.

CROSSFADER REPLACEMENT

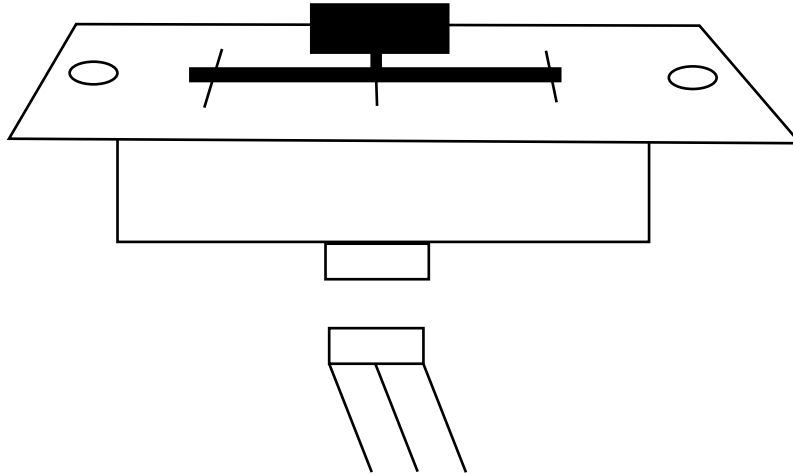

The crossfader is “Hot Swapable” which means it may be replaced at any time, even when power is applied. Only replace with American Audio Part Feather Fader Plus. Replacing with any other model fader may seriously damage your mixer. Please, always use insulated tools.

Replacing the Crossfader:

1. Using a Phillips screw driver, unscrew the six stainless steel retainer screws that hold the mixer face plate in place.
2. Gently remove the crossfader knob. Lift and remove the mixer face plate to access the cross fader. Carefully pull the crossfader up from its seated position.
3. After removing the crossfader, disconnect the ribbon cable that attaches the crossfader to the PC board. Grasp the crossfader by its base and pull the ribbon cable by its connector not the actual cables. The connector is designed to only fit one way, so don't worry about the connectors orientation.
4. Unscrew the ground cable from the crossfader plate. Now unscrew the crossfader from the crossfader plate and replace with the new crossfader. Connect the ground cable to the cross fader plate.
5. Connect the new crossfader to the ribbon cable and replace in reverse order.

NOTE: All other areas of the VERSADECK are not to be opened or replaced by user, dealer, or unauthorized service centers. These actions will result in a voided warranty.

TROUBLESHOOTING

USB device not reading	<p>When using Hard Drives it is recommended that you use a hard drive with an external power supply or one that does not exceed 5 volt power consumption. If your hard drive resets itself when plugged into the USB ports on the Versa Deck you may need an external power supply. Contact your device manufacturer for accessory information.</p> <p>If the drive doesn't read the device, make sure that your device is formatted to a compatible FAT format. WARNING-DO NOT FORMAT YOUR DEVICE WITH OUT BACKING UP YOUR FILES.</p>
Music files not found in USB device or Database	<ul style="list-style-type: none">-Make sure that the file is an MP3 file.- If it does not show up on the database modes (album; artist; etc) use the database builder to update you library.
File Error when building dB file	<p>Remove the file that cause the database builder to stop and try again, if problem continues remove the folder and try again.</p>

WARRANTY

WARRANTY INFORMATION: The VERSADECK carries a ONE year (365 days) limited warranty. This warranty covers parts and labor. Please fill out the enclosed warranty card to validate your purchase and warranty. All returned service items whether under warranty or not, must be freight pre-paid and accompany a return authorization (R.A.) number. If the unit is under warranty, you must provide a copy of your proof of purchase invoice. Please contact American Audio® customer support at (800) 322-6337 for a R.A. number. All package not displaying a R.A. number on the outside of the package will be returned to the shipper.

1-YEAR LIMITED WARRANTY

A. American Audio® hereby warrants, to the original purchaser, American Audio® products to be free of manufacturing defects in material and workmanship for a period of 1 Year (365 days) from the date of purchase. This warranty shall be valid only if the product is purchased within the United States of America, including possessions and territories. It is the owner's responsibility to establish the date and place of purchase by acceptable evidence, at the time service is sought.

B. For warranty service, send the product only to the American Audio® factory. All shipping charges must be pre-paid. If the requested repairs or service (including parts replacement) are within the terms of this warranty, American Audio® will pay return shipping charges only to a designated point within the United States. If the entire instrument is sent, it must be shipped in its original package. No accessories should be shipped with the product. If any accessories are shipped with the product, American Audio® shall have no liability whatsoever for loss of or damage to any such accessories, nor for the safe return thereof.

C. This warranty is void if the serial number has been altered or removed; if the product is modified in any manner which American Audio® concludes, after inspection, affects the reliability of the product; if the product has been repaired or serviced by anyone other than the American Audio® factory unless prior written authorization was issued to purchaser by American Audio®; if the product is damaged because not properly maintained as set forth in the instruction manual.

D. This is not a service contract, and this warranty does not include maintenance, cleaning or periodic check-up. During the period specified above, American Audio® will replace defective parts at its expense, and will absorb all expenses for warranty service and repair labor by reason of defects in material or workmanship. The sole responsibility of American Audio® under this warranty shall be limited to the repair of the product, or replacement thereof, including parts, at the sole discretion of American Audio®. All products covered by this warranty were manufactured after January 1, 1990, and bear identifying marks to that effect.

E. American Audio® reserves the right to make changes in design and/or improvements upon its products without any obligation to include these changes in any products theretofore manufactured.

F. No warranty, whether expressed or implied, is given or made with respect to any accessory supplied with products described above. Except to the extent prohibited by applicable law, all implied warranties made by American Audio® in connection with this product, including warranties of merchantability or fitness, are limited in duration to the warranty period set forth above. And no warranties, whether expressed or implied, including warranties of merchantability or fitness, shall apply to this product after said period has expired. The consumer's and or Dealer's sole remedy shall be such repair or replacement as is expressly provided above; and under no circumstances shall American Audio® be liable for any loss or damage, direct or consequential, arising out of the use of, or inability to use, this product.

G. This warranty is the only written warranty applicable to American Audio® Products and supersedes all prior warranties and written descriptions of warranty terms and conditions heretofore published.

SPECIFICATIONS

GENERAL Mixer	Model: American Audio VERSADECK - Professional DUAL USB Player/ Mixer
Type:	Dual USB MP3 Player + Digital Mixer
Disc type:	Applicable File Extensions for Mp3s: mp3, MP3, mP3, and Mp3
Pitch Range:	Within +/- 6%, +/- 10%, and +/- 16%
Pitch Accuracy:	+/-0.15%
Dimensions:	420mm (W) x 300mm (D) x 91mm (H)
Installation:	Place on flat surface or mount in flat case
Weight:	9.74 Lbs. / 4.42 Kgs
Power supply:	AC 100~240V, 50/60Hz (Universal)
Power consumption:	21W
Environmental conditions:	Operational temperature: 5 to 35°C (41 to 95°F) Operational humidity: 25 to 85% RH (no condensation) Storage temperature: -10 to 60°C (14 to 140°F)

MIXER SECTION

Input/Output Impedance & Sensitivity (Level/Impedance): (Master set to 0dBV output, Load=100K OHM, maximum gain, EQ Flat)

Input Impedance & Reference Input Level:

LINE:	47K OHM /-14dBV (200mV) +/-0.1dB
PHONO:	47K OHM /-50dBV (3.16mV) +/-0.1dB
MIC:	10K OHM /-50dBV (3.16mV) +/-0.1dB

Output Impedance & Sensitivity:

MASTER:	1K OHM /0dBV (1V) +/-2dB
MASTER XLR (Load=600OHM):	600 OHM /+4dBm (1.23V) +/-3dB
BOOTH:	1K OHM /0dBV (1V) +/-2dB
PHONES (Load=32OHM):	33 OHM /0dBV (1V) +/-2dB

Maximum Input (1KHz, THD=1%, EQ flat, Maximum Gain, Load=100K OHM)

LINE:	More than +0dBV
PHONO:	More than -36dBV
MIC:	More than -36dBV

Maximum Output (1KHz, THD=1%, EQ flat, Maximum Gain, Load=100K OHM)

MASTER:	More than +15dBV (5.62V) Load=100K OHM
PHONES:	More than +4dBV (1.6V) Load=32 OHM

Frequency Response (EQ Flat, Maximum Gain, Load=100K OHM)

LINE:	20-20KHz +/-2dB
PHONO:	20-20KHz +2/-3dB (RIAA)
MIC:	20-20KHz +2/-3dB

THD+N - Total Harmonic Distortion: (EQ Flat, Maximum Gain, W/20kHz LPF, A-Weighted, Load=100K OHM):

LINE:	Less than 0.06% @ 1KHz
PHONO:	Less than 0.08% @ 1KHz
MIC:	Less than 0.15% @ 1KHz

S/N Ratio (Maximum Gain, EQ Flat, W/20KHz LPF, A-Weighted):

LINE:	More than 73dB
PHONO:	More than 73dB
MIC:	More than 63dB

SPECIFICATIONS

Cross Talk (Maximum Gain, EQ Flat, W/20KHz LPF, A-Weighted, Master=0dBV Output)

LINE, PHONO: More than 63dB @1Khz Between L and R Channel
More than 70dB @1KHz Between Channels

Equalizer:

MIC: -14 +/-3dB at 100Hz

-12 +/-3dB at 10KHz

CHANNEL:

10 +/-2dB, Below -30dB at 70Hz

10 +/-2dB, Below -30dB at 1KHz

10 +/-2dB, Below -30dB at 13KHz

Fader Kill: (Maximum Gain, EQ Flat, W/20KHz LPF, A-Weighted, Master=0dBV Output)

Channel Fader: More than 70dB at 1KHz

Crossfader: More than 70dB at 1KHz

Channel Balance: Within 2dB

Talkover: -20dB +/-2dB

USB PLAYER SECTION

USB HOST PLAYER SECTION: (SIGNAL FORMAT: MP3, 128KBPS)

Output Level: 0dBV +/-2dB (TCD782 TRK16, Gain Maximum, EQ Flat)

Frequency Response: 17-16KHz +/-2dB (TCD781 TRK1,4,16, Set Gain to 0dBV Out, EQ Flat)

T.H.D. + NOISE: Less than 0.08% (TCD782 TRK16 Gain Maximum, EQ Flat, W/20KHz LPF, A-Weighted)

S/N Ratio: More than 70dB (TCD782 TRK2,8, Set Gain to 0dBV Out, EQ Flat, W/20KHz LPF, A-Weighted)

LR Separation: More than 63dB @ 1KHz (TCD782 TRK2,9,11, Set Gain to 0dBV Out, EQ Flat, W/20KHz LPF, A-Weighted)

USB SLAVE PLAYER SECTION: (SIGNAL FORMAT: MP3, 128KBPS)

Output Level: 0dBV +/-2dB (TCD782 TRK16, Gain Maximum, EQ Flat)

Frequency Response: 17-16KHz +/-2dB (TCD781 TRK1,4,16, Set Gain to 0dBV Out, EQ Flat)

T.H.D. + NOISE: Less than 0.08% (TCD782 TRK16 Gain Maximum, EQ Flat, W/20KHz LPF, A-Weighted)

S/N Ratio: More than 70dB (TCD782 TRK2,8, Set Gain to 0dBV Out, EQ Flat, W/20KHz LPF, A-Weighted)

LR Separation: More than 63dB @ 1KHz (TCD782 TRK2,9,11, Set Gain to 0dBV Out, EQ Flat, W/20KHz LPF, A-Weighted)

Recording & Playback: (Line 1KHz, -14dBV Input, Gain Maximum)

Output: 6dBV (2V) +/-2dB

T.H.D. + Noise: Less Than 0.08% (Gain Maximum, W/20KHz LPF, A-Weighted)

NOTES: Specifications and improvements in the design of this unit and this manual are subject to change without any prior written notice.



SPECIFICATIONS

MP3 FORMAT

USB Format	File System	FAT 12/16/32
	Applicable file extensions	mp3. MP3. mP3. Mp3
	Max. number of Folders	999
	Max. number of files	Max. 999 files
MP3 Format	MPEG 1 Layer 3 standard (ISO/IEC 11172-3), which provides for single channel ('mono') and two-channel ('stereo') coding at sampling rates of 32, 44.1 and 48kHz.	32/40/48/56/80/96/112/128/160/192/224/256/320 kbps Xing/VBRI VBR
	MPEG 2 Layer 3 standard (ISO/IEC 13818-3), which provides for similar coding at sampling rates of 16, 22.05 and 24 kHz.	32/40/48/56/64/80/96/112/144/160 Kbps Xing/VBRI VBR
	MPEG 2.5 Layer 3 standard, which provides for similar coding at sampling rates of 8, 11.025 and 12 kHz.	32/40/48/56/64/80/96/112/144/160 Kbps Xing/VBRI VBR



Follow Us On:



facebook.com/americanDJ
twitter.com/americanDJ
youtube.com/adjlighting

©American Audio® World Headquarters:
6122 S. Eastern Ave. Los Angeles, CA 90040 USA
Tel: 323-582-3322 Fax: 323-582-3311

Web: www.AmericanAudio.us E-mail: info@americanaudio.us

American DJ Europe
Junostraat 2
6468 EW Kerkrade
Netherlands

service@adjgroup.eu / www.americandj.eu
Tel: +31 45 546 85 00 / Fax: +31 45 546 85 99