



DH-100V HIGH EFFICIENCY DEHUMIDIFIER

INSTALLATION
OPERATION
MAINTENANCE
972 DH 09-12

ALDES DH-100V

Installation, Operation & Service Instructions



Read the installation, operation and maintenance instructions carefully **before** installing and using this unit. Proper adherence to these instructions is essential to obtain maximum benefit from your DH-100V dehumidifier.

Table of Contents

1. Specifications.....	1
2. Installation	1
2.1 Location	1
2.1A In humid area, no ducting.	1
2.1B In humid area, duct inlet and/or outlet.	1
2.1C In remote area, duct inlet & outlet.....	2
2.1D In remote area, duct outlet only.....	2
2.1E In remote area, duct inlet only.	2
2.2 Electrical Requirements	2
2.3 Condensate Removal.....	2
2.4 Ducting	2
2.4A Optional Ducting	2
2.4B Ducting for Dehumidification	2
2.4C Ducting for Fresh Air.....	3
3. Operation	3
3.1 Humidity Control Adjustment.....	3
3.2 Fan Switch.....	3
4. Maintenance	3
4.1 Air Filter	3
4.2 Blower Oiling	3
5. Service	4
5.1 Warranty.....	4
5.2 Technical description	4
5.3 Troubleshooting.....	4
5.4 Refrigerant Charging.....	5
5.5 Blower Replacement	5
5.6 Compressor/Capacitor Replacement.....	5
5.6A Checking Compressor Motor Circuits.....	5
5.6B Replacing a Burned Out Compressor.....	5
5.6C Replacing a Compressor- Nonburn Out	6
5.7 Humidity Control.....	6
5.8 Defrost Thermostat.....	6
5.9 Condensate Pump.....	6
6. Wiring Diagrams	7
7. Service Parts List.....	8
8. Warranty.....	9
9. Service Notes	10

1 Specifications

Model: DH-100V Dehumidifier
 Electrical: 110-120 VAC, 6.8 Amps, grounded
 Capacity: 100 pints/day @ 80°F, 60% RH
 Operating Temp. Range: 53°F min, 105°F max
 Air Flow: 255 CFM without external ducting
 170 CFM @ 0.15 in.wg. external static
 Refrigerant Charge: 1 lbs., 14oz. R-22
 Optional Duct connections: 8" round inlet & outlet
 Size (w/o duct collars): 20" long x 17" wide x 36" high
 Weight: 103 lbs.

2 Installation

2.1 Location

The DH-100V can be installed in a variety of locations to meet the owner's needs as listed below. In all cases, keep the following cautions in mind:

- It is designed to be installed **INDOORS ONLY**.
- If used near a pool or spa, be certain there is **NO** chance the unit could roll into the water or be splashed and that it is plugged into a **GROUND FAULT INTERRUPTER**.
- **DO NOT** use the DH-100V as a bench or table.
- Avoid discharging the air directly at people, especially in pool areas.

2.1A In humid area, no ducting.

The simplest installation is to place the DH-100V in the humid area with no ducting. The air inlet on top & outlet on the side must be at least 1' from walls and other obstructions to air flow.

2.1B In humid area, duct inlet and/or outlet.

If the humid area is very large or has high ceilings, dehumidification can be improved by adding an inlet and/or outlet duct to circulate and destratify stagnant areas. For a large area, add inlet or outlet ducting to create flow across the area's greatest length. For areas with ceilings higher than 12', use an inlet duct to draw warm, moist air from near the ceiling. See section 2.4 for attaching duct collars & ducting.

Serial No. _____

Purchase Date _____

Dealer's Name _____

2.1C In remote area, duct inlet & outlet.

It is often desirable, especially in pool rooms and finished areas, to install the DH-100V in an adjacent equipment room or unfinished area. Air is transferred between the humid room and the unit via ducting.

The factory mounted humidity control on the DH-100V cabinet may not sense the humidity in the humid room accurately enough with this installation method. If so, an additional humidity control can be mounted in the humid room and wired to the DH-100V. Local electrical codes must be followed when wiring the control.

2.1D In remote area, duct outlet only.

A simpler remote installation method than the one above uses ducting only between the DH-100V discharge and the humid room; the DH-100V inlet draws air from the room in which it's located. This works well if there is an adequate air flow path between the two rooms; e.g., high door undercut, louvered door or wall grill. This eliminates the need to remote mount the humidity control. There are several potential disadvantages to using this method. First, humid air is drawn into the room where the DH-100V is located. Second, to accurately sense humidity, the blower in the DH-100V may need to run continuously to draw air from the humid room into the DH-100V room. Third, a slight negative pressure is created in the room with the DH-100V which could back draft open combustion devices located there. If such devices are present, call the factory for specific instructions before using this installation method or consider the option below.

2.1E In remote area, duct inlet only.

When the DH-100V is located in a room separate from the main area to be dehumidified, it may be desirable to dehumidify and/or slightly pressurize that room. Pressurization assures that open combustion devices do not back draft, as would be the case if the room were sufficiently depressurized. This can be accomplished by installing a duct from the humid room to the DH-100V inlet and by allowing the DH-100V to discharge the dehumidified air into the room in which it's located. An adequate airflow path must exist between the two rooms for this method to work well. An additional humidity control may need to be mounted in the humid area and wired to the DH-100V to accurately maintain the desired humidity. Local electrical codes must be followed when wiring the control.

2.2 Electrical Requirements

The DH-100V plugs into a common grounded outlet on a 15 Amp circuit. It draws between 6 and 7 Amps under normal operating conditions. If used in a wet area (pool, spa room, or basement prone to flooding), a ground fault interrupter protected circuit is required.

If an extension cord is required, it must have a minimum of 16 gauge conductors if less than 25 feet long and 14 gauge if greater than 25 feet.

2.3 Condensate Removal

Condensate drains by gravity via the clear hose extending from the unit. Route the hose to a floor drain. Use care to keep the hose as flat to the floor as possible. Excessive humps will prevent proper drainage.

If the DH-100V is located too far from a floor drain for the attached hose to reach, inexpensive 1/2" PVC pipe can be used to extend it. It is commonly available in 10' lengths from building supply, plumbing and hardware stores. It will slide tightly inside the end of the drain hose.

If more than one length of pipe is required, they can be joined with a short piece cut from the end of the drain hose.

2.4 Ducting

2.4A Optional Ducting

An inlet shroud with a 8" round collar and an 8" round exhaust collar are available from the factory that will allow round ducting to be attached to the inlet and/or outlet of the DH-100V.

2.4B Ducting for Dehumidification

Ducting the DH-100V as mentioned in sections 2.1B-2.1E requires consideration of the following points:

Duct Sizing: For total duct lengths up to 25 feet, use a minimum 8" diameter round or equivalent rectangular. For longer lengths, use a minimum 10" diameter or equivalent. Grills or diffusers on the duct ends must not excessively restrict airflow.

Isolated Areas: Effective dehumidification may require that ducting be branched to isolated, stagnant areas. Use 6" diameter branch ducting to each of two or three areas, use 4" to each of four or more areas.

2.4C Ducting for Fresh Air

Fresh air can be brought into the structure continuously by connecting a duct from outside to the DH-100V inlet and by turning on the fan switch. Advantages of this form of ventilation include:

1. Outside air is filtered before entering the building.
2. Outside air will be dehumidified before entering if the DH-100V is running.
3. Drawing air from outside and blowing inside aids in pressurizing the structure. This helps prevent unfiltered and humid air from entering elsewhere. It also reduces the potential for carcinogenic radon gas to enter.
4. The need for an alternate ventilation device may be eliminated.

(Note: Aldes Model DHV-100V is specifically designed for dehumidification and ventilation.)

An insulated 6" diameter duct is generally sufficient to provide up to 100 CFM of outside air. An adjustable damper is recommended for controlling the airflow. Large quantities of outside air will impact the DH-100V's performance positively or negatively, depending upon the difference between inside and outside air conditions. Consult the factory by calling 1-800-255-7749 for recommendations regarding the use of higher flows with your specific application.

The outside air duct should be connected into the main inlet duct close to the unit. If no other inlet duct is used, locate the outside air duct end on top of and as close as possible to the DH-100V air filter.

3 Operation

3.1 Humidity Control Adjustment

Set the humidity control to the desired humidity level for the home. The dehumidifier will run continuously until the relative humidity (RH) is reduced to the humidity control dial setting. Setting the humidity control to lower RH levels will **NOT** increase the unit's dehumidification rate; the unit will simply run longer to reduce the area's RH to the setting. The ALDES DHV-100V unit (and refrigerant based dehumidifiers in general) will reduce a warm space's RH to a lower level than that of a cool space. It is therefore pointless to set the humidity control to excessively low levels in cool rooms; doing so will result in long periods of ineffective dehumidifier run time.

Quality humidity meters are available from the factory and are recommended to accurately monitor humidity levels.

3.2 Blower Switch

Turning ON the fan switch will cause the unit's internal blower to run continuously, whether the unit is dehumidifying or not. This function is desirable if the unit is used for air circulation or fresh air ventilation.

4 Maintenance

4.1 Air Filters

The DH-100V is equipped with 2 air filters. A foam prefilter followed by a pleated fabric filter. These should be checked monthly. Operating the unit with dirty filters will reduce dehumidifier capacity and efficiency and may cause the compressor to cycle off and on unnecessarily on the defrost control.

If dirty, the foam prefilter can be vacuumed or carefully hand washed with warm water and mild detergent, then rinsed. The pleated fabric filter can generally be vacuumed clean several times before needing replacement. Replacement filters can be ordered from the factory or purchased locally if available. **DO NOT** operate the unit without the filters or with a less effective filter. The heat exchange coils inside the unit could become clogged and require disassembly to clean.

4.2 Blower Oiling

The blower motor is factory lubricated for many years of normal operation. However, periodic oiling will extend motor bearing life. To oil, remove the plastic cap from the two oiling tubes extending from the unit above the humidity control (see Figure 3). Add 3 to 5 drops of SAE 20 non-detergent oil to each port every 6 months. **DO NOT** use thinner oil or penetrating oil. Blower life can actually be decreased by such oil.

5 Service

CAUTION: Servicing the DH-100V with its **high-pressure** refrigerant system and **high voltage** circuitry presents a health hazard, which could result in **death**, serious bodily **injury**, and/or property **damage**. Only qualified service people should service this unit.

5.1 Warranty

See page 9 for warranty terms. Read the warranty before any repair is initiated. If a warranty repair is required, call the factory first at 1-800-255-7749 for warranty claim authorization and technical assistance.

5.2 Technical Description

The DH-100V uses a refrigeration system similar to an air conditioner's to remove heat and moisture from incoming air, and add heat to the air that is discharged (see Fig. 1).

Hot, high-pressure refrigerant gas is routed from the compressor to the condenser coil (see Fig. 1). The refrigerant is cooled and condensed by giving up its heat to the air that is about to be discharged from the unit. The refrigerant liquid then passes through a filter/drier and capillary tubing, which cause the refrigerant pressure and temperature to drop. It next enters the evaporator coil where it absorbs heat from the incoming air and evaporates.

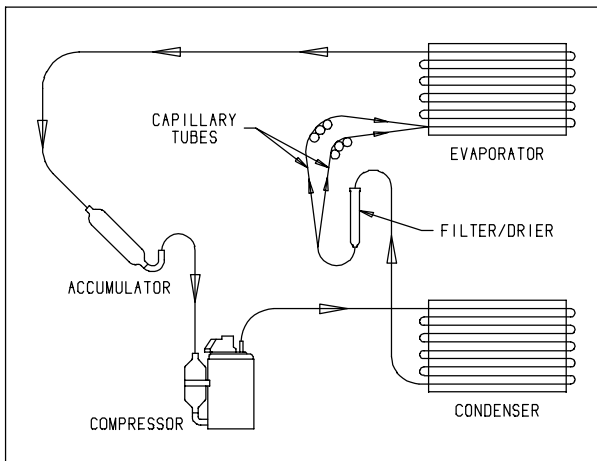

Figure 1: Refrigeration System of DH-100V

The evaporator operates in a flooded condition, which means that all the evaporator tubes contain liquid refrigerant during normal operation. A flooded evaporator should maintain constant pressure and temperature across the entire coil, from inlet to outlet.

The mixture of gas and liquid refrigerant enter the accumulator after leaving the evaporator coil. The accumulator prevents any liquid refrigerant from reaching the compressor. The compressor evacuates the cool refrigerant gas from the accumulator and compresses it to a high pressure and temperature to repeat the process.

5.3 Troubleshooting

No dehumidification, neither blower nor compressor run with fan switch OFF.

1. Unit unplugged or no power to outlet.
2. Humidity control set too high or defective (Sec. 3.1 & 5.7).
3. Loose connection in internal wiring.

No dehumidification, compressor does not run but blower runs with fan switch OFF and humidity control turned to ON.

1. Defective compressor run capacitor (Sec. 5.6).
2. Loose connection in compressor circuit (see Fig. 2).
3. Defective compressor overload (Sec. 5.6A).
4. Defective compressor (Sec. 5.6).
5. Defrost thermostat open (Sec. 5.8).

Blower runs with fan switch OFF, but compressor cycles on & off.

1. Low ambient temperature and/or humidity, causing unit to cycle through defrost mode.
2. Defective compressor overload (Sec. 5.6A).
3. Defective compressor (Sec. 5.6).
4. Defrost thermostat defective (Sec. 5.8).

Blower does not run with fan switch in either position. Compressor runs briefly but cycles on & off.

1. Loose connection in blower circuit (see Fig. 2).
2. Obstruction prevents impeller rotation.
3. Defective blower.
4. Blower switch defective.

Evaporator coil frosted continuously, low dehumidifying capacity.

1. Defrost thermostat loose or defective (Sec. 5.8).
2. Low refrigerant charge
3. Dirty air filter or airflow restricted.

5.4 Refrigerant Charging

If the refrigerant charge is lost due to service or a leak, a new charge must be accurately weighed in. If any of the old charge is left in the system, it must be removed before weighing in the new charge. Refer to the unit nameplate for the correct charge weight and refrigerant type.

5.5 Blower Replacement

The centrifugal blower has a PSC motor and internal thermal overload protection. If defective, the complete assembly must be replaced.

1. Unplug the power cord.
2. If an outlet duct is connected to the unit, remove it.
3. Remove the cabinet side.
4. Remove the 4 screws holding the electrical box located next to the blower.
5. Disconnect the blower leads. Black from the blower switch, and white the run capacitor.
6. Unbolt the blower capacitor from the blower motor (required for removal clearance). Pull the oil tubes out of the motor.
7. Remove the nuts & bolts holding the blower outlet flange to the cabinet end and remove the blower.
8. Reassembling with the new blower is the above procedure reversed.

5.6 Compressor/Capacitor Replacement

This compressor is equipped with a two terminal external overload, run capacitor, but no start capacitor or relay. See Fig. 2.

CAUTION-ELECTRICAL SHOCK HAZARD: Electrical power must be present to perform some tests; these tests should be performed by a qualified service person.

5.6A Checking Compressor Motor Circuits

Perform the following tests if the blower runs but the compressor does not with the blower switch OFF and the humidity control ON.

1. Unplug the unit, remove the cabinet side (with two screws in center) and the electrical connection cover on the compressor top.
2. Plug in the unit and turn the humidity control to ON. Check for 110 volts from compressor terminal R to overload terminal 3 using an AC voltmeter. If voltage is present, go to step 3. If no voltage, the high-pressure control or relay are open or there is a loose connection in the compressor circuit. Test each component for continuity; see the appropriate section if a defect is suspected.
3. Unplug the unit, then disconnect the red and yellow wires from compressor terminals R & S. Using an ohmmeter, check continuity between the points listed below.

4. Compressor terminals C and S: No continuity indicates an open start winding. The compressor must be replaced. Normal start winding resistance 3 to 7 ohms.
5. Compressor terminals C and R: No continuity indicates an open run winding. The compressor must be replaced. Normal run winding resistance is .5 to 2 ohms.
6. Compressor terminal C and overload terminal 1: No continuity indicates a defective overload lead.
7. Overload terminals 1 and 3: If there is no continuity, the overload may be tripped. Wait 10 minutes and try again. If there is still no continuity, it is defective and must be replaced.
8. Compressor terminal C and compressor case: Continuity indicates a grounded motor. The compressor must be replaced.
9. Disconnect the yellow wires from the capacitor. Set the ohmmeter to the Rx1 scale. The capacitor is shorted and must be replaced if continuity exists across its terminals. If there is no needle movement with the meter set on the Rx100000 scale, the capacitor is open and must be replaced.
10. Reconnect the wires to the compressor and capacitor. Plug in and turn on the unit. If the compressor fails to start, replace the run capacitor.
11. If the unit still doesn't start, adding a hard-start kit (relay & capacitor) will provide greater starting torque. If this doesn't work, the compressor has an internal mechanical defect and must be replaced.

5.6B Replacing a Burned Out Compressor

The refrigerant and oil mixture in a compressor is chemically very stable under normal operating conditions. However, when an electrical short occurs in the compressor motor, the resulting high temperature arc causes a portion of the refrigerant oil mixture to break down into carbonaceous sludge, a very corrosive acid, and water. These contaminants must be carefully removed otherwise even small residues will attack replacement compressor motors and cause failures.

The following procedure is effective only if the system is monitored after replacing the compressor to insure that the clean up was complete.

1. This procedure assumes that the previously listed compressor motor circuit tests revealed a shorted or open winding. If so, cautiously smell the refrigerant from the compressor service port for the acid odor of a burn out.

WARNING: The gas could be toxic and highly acidic. If no acid odor is present, skip down to the section on changing a non-burn out compressor.

2. Remove and properly dispose of the system charge. **DO NOT** vent the refrigerant indoors or allow it to contact your eyes or skin.
3. Remove the burned out compressor. Use rubber gloves if there is any possibility of contacting the oil or sludge.
4. To facilitate subsequent steps, determine the type of burn out that occurred. If the discharge line shows no evidence of sludge and the suction line is also clean or perhaps has some light carbon deposits, the burn out occurred while the compressor was not rotating. Contaminants are therefore largely confined to the compressor housing. A single installation of liquid and suction line filter/driers will probably clean up the system.

If sludge is evident in the discharge line, it will likely be found in the suction line; this indicates the compressor burned out while running. Sludge and acid has been pumped throughout the system. Several changes of the liquid and suction filter/driers will probably be necessary to cleanse the system.

5. Correct the system fault that caused the burn out. Consult the factory for advice.
6. Install the replacement compressor with a new capacitor and an oversized liquid line filter.

In a running burn out, install an oversized suction line filter/drier between the accumulator and compressor. Thoroughly flush the accumulator with refrigerant to remove all trapped sludge and to prevent the oil hole from becoming plugged. A standing burn out does not require a suction line filter/drier.

7. Evacuate the system with a good vacuum pump and accurate vacuum gauge. Leave the pump on the system for at least an hour.

An alternate method of removing moisture and non-condensibles from the system requires evacuation to 29" Hg vacuum. Then break the vacuum with 35 to 50 PSIG refrigerant vapor charge. Leave the vapor charge in the system for at least 5 minutes before removing it. Repeat the vapor charge/wait/remove sequence twice more and then charge the system with the quantity and refrigerant listed on the nameplate.

8. Operate the system for a short period of time, monitoring the suction pressure to determine that the suction filter is not becoming plugged. Replace the suction filter/drier if pressure drop occurs. If a severe running burn out has occurred, several filter/driers may have to be replaced to remove all of the acid and moisture.

NOTE: NEVER use the compressor to evacuate the system or any part of it.

5.6C Replacing a Compressor- Nonburn Out

Remove the refrigerant from the system. Replace the compressor and liquid line filter/drier. Charge the system to 50 PSIG and check for leaks. Remove the charge and weigh in the refrigerant quantity listed on the nameplate. Operate the system to verify performance.

5.7 Humidity Control

The humidity control is an adjustable switch that closes when the relative humidity of the air in which it is located rises to the dial set point. It opens when the RH drops 4 to 6% below the set point.

5.8 Defrost Thermostat

The defrost thermostat is attached to the refrigerant suction tube between the accumulator and compressor. It will automatically shut the compressor off if the low side refrigerant temperature drops due to excessive frost formation on the evaporator coil. The blower will continue to run, causing air to flow through the evaporator coil and melt the ice. When the ice has melted, the evaporator temperature will rise and the thermostat will restart the compressor.

5.9 Condensate Pump

Condensate is automatically pumped to a remote location when the water level in the pump's reservoir rises to close the float switch.

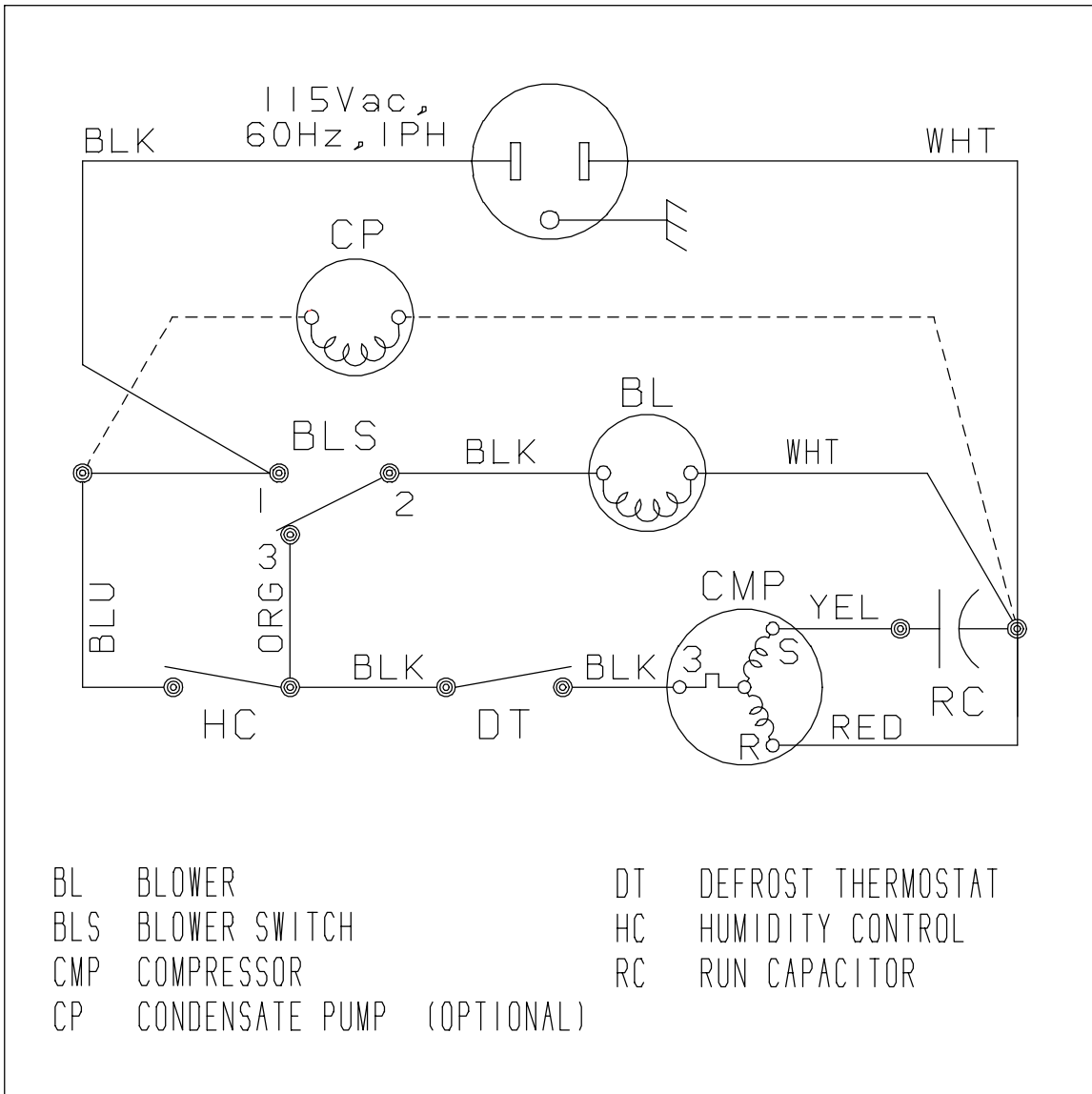

Figure 2: Electrical Schematic of the DH-100V Dehumidifier

SERVICE PARTS LIST: DH-100V Dehumidifier

ITEM	PART NO.	QTY.	DESCRIPTION
1	4021818	1	Accumulator
2	AL99005	1	Air Filter, Pleated, 2" x 16" x 20"
3	4021468	1	Air Filter, Foam Element
4	4022037	1	Blower w/ Capacitor (Fasco 7090-1874)
5	4021589	2	Capillary Tubes, .050" ID x 28" long
6	4023474	1	Compressor, Panasonic (2R12S3R126A-6A)
7	4022144	1	Compressor Overload (TI # MRA98706-673) (not shown)
8	4017318	1	Compressor Run Capacitor for Panasonic, 35 MFD, 370V
	4017799	1	Compressor Run Capacitor for Tecumseh, 25 MFD, 440V
9	4021396	1	Condenser Coil
10	4021409	1	Cord & Wire Harness
11	4021470	1	Defrost Thermostat
	4021648	1	Defrost Thermostat Mounting Clip (item 11)
12	4021395	1	Evaporator Coil
13	4020955	1	Filter/Drier
14	4021626	1	Hose, Drain, .56"ID x 8'
15	4021469	1	Humidity Controller
16	4021495	1	Knob, Humidity Controller
17	4020554	1	Switch, SPDT, for Fan
18	4021471	4	Wheel, 2", Plastic
19	4021507	1	Wiring Diagram (on Cover) (not shown)
20	4021453	1	Optional Ducting Kit (for Inlet & Outlet) (not shown)
21	4020623	1	Optional Outlet Collar (for Ducting Outlet only) (not shown)

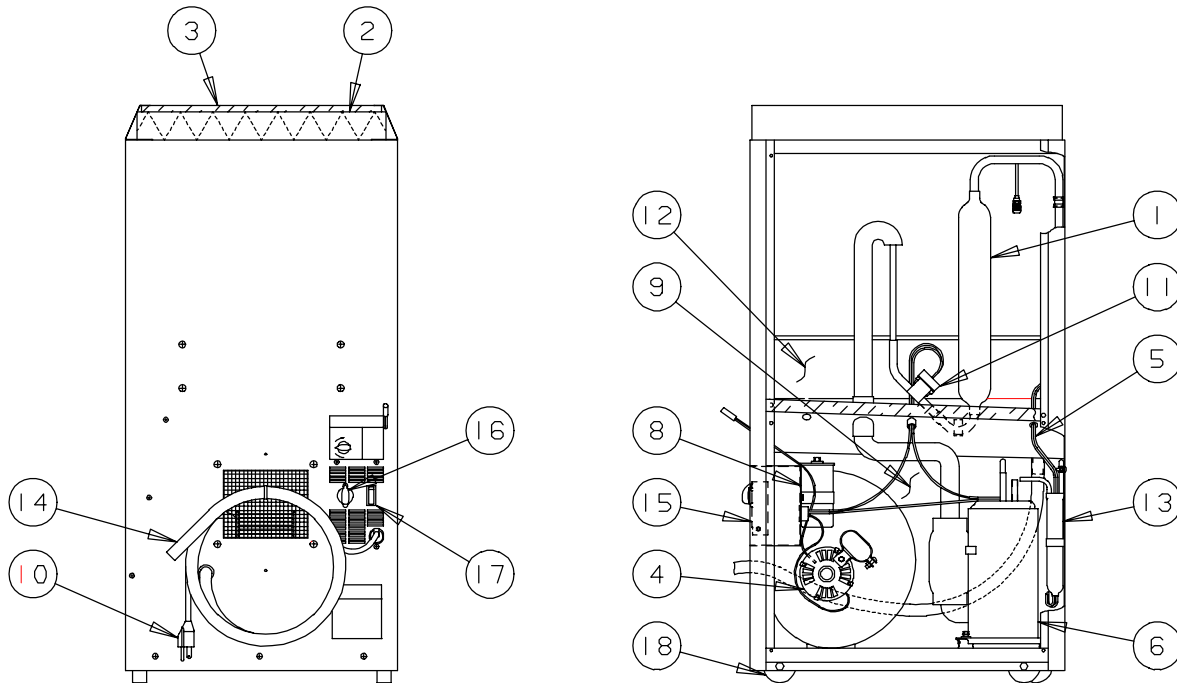

Figure 3

Limited Warranty

American ALDES Ventilation Corporation warrants to the original end user of the Dehumidifier or Dehumidifying Ventilator model referred to below, to be free from manufacturing defects. It is limited to the original end-user and may not be assigned or transferred.

First Year Warranty: If the product exhibits a defect in materials or workmanship within one (1) year after purchase, American ALDES, at its option, will repair or replace the unit free of charge for materials and labor.

Second through Fifth Year: American ALDES warrants that for a period of five (5) years, the condenser, evaporator, and compressor of the unit will operate free of defect in materials or workmanship, or American ALDES, at its option will repair or replace the defective parts, provided that labor and transportation costs are borne by the end-user.

Proof of purchase: The end-user must provide a dated proof of purchase upon request, by copy of invoice from American ALDES, or the installing dealer.

End-User Responsibilities: Warranty service must be performed by a Servicer authorized by American ALDES Ventilation Corporation. If the end-user is unable to locate or obtain warranty service from an authorized Servicer, he should call American ALDES Ventilation Corporation (1-800-255-7749) to arrange for covered warranty service. Warranty service will be performed during normal business hours.

The end-user is responsible for normal care, including normal maintenance, filter replacement, as outlined in the installation and operating instructions. This warranty applies only to residential applications and does not cover any defect or malfunction, etc., resulting from misuse, abuse, lack of maintenance, corrosion, freezing, modification, unauthorized or improper repair or installation, accident, acts of nature, or any other cause beyond American ALDES Ventilation Corporation's reasonable control.

Limitations and Exclusions: If any American ALDES Dehumidifier/Dehumidifying Ventilator part is repaired or replaced, the new part shall be warranted for only the remainder of the original warranty period applicable thereto. All warranty periods shall be extended by the period of time, if any, that the unit is out of service while awaiting covered warranty service.

Upon the expiration of the written warranty applicable to the Dehumidifier/Dehumidifying Ventilator or any part thereof, all other warranties implied by law, including merchantability and fitness for a particular purpose, shall also expire.

American ALDES makes no express warranties, except for those that are set forth herein and shall not be liable for any incidental, special, or consequential damages, including without limitation water damage (the end-user should take precautions against same), lost profits, delay, or loss of use or damage to any real or personal property, with respect to the American ALDES products covered by this warranty. American ALDES complete liability and the owner's exclusive remedy are limited to repair or replacement according to the terms stated herein.

No person is authorized to change the warranty in any way or grant any other warranty unless such changes are made in writing and signed by an officer of American ALDES Ventilation Corporation.

Some states do not allow limitations of how long an implied warranty lasts, and some do not allow the exclusion or limitation of incidental or consequential damages, so one or both of these limitations by not apply to you.

Legal Rights: This warranty gives you specific legal rights, and you may have other rights, which vary from state to state.

American ALDES Ventilation Corporation, 4537 Northgate Ct. Sarasota, FL 34234 (800) 255-7749

Model: _____ Unit Serial No. _____

Installed by: _____
Date: _____

Date	Service Notes
-------------	----------------------
