



---

MANUAL PART NUMBER: 400-0442-007

**DS801-111**

**INTERA<sup>®</sup> COMPUTER/COMPONENT  
VIDEO+ STEREO AUDIO  
TWISTED PAIR (UTP) RECEIVER**

## TABLE OF CONTENTS

---

	Page
PRECAUTIONS / SAFETY WARNINGS .....	2
GENERAL.....	2
INSTALLATION .....	2
CLEANING.....	2
FCC NOTICE .....	2
ABOUT YOUR DS801-111.....	3
TECHNICAL SPECIFICATIONS .....	3
PRODUCT DESCRIPTION .....	5
APPLICATION DIAGRAMS.....	6
DIAGRAM 1: TYPICAL SETUPS .....	6
DIAGRAM 2: INTERNAL VIEW .....	7
INSTALLING YOUR DS801-111 .....	8
OPERATION.....	8
VIDEO EQUALIZATION.....	8
TROUBLESHOOTING GUIDE .....	8
NO DISPLAY.....	8
NO SOUND.....	9
ALTINEX POLICIES .....	9
LIMITED WARRANTY/RETURN POLICIES.....	9
CONTACT INFORMATION .....	9

## PRECAUTIONS / SAFETY WARNINGS 1

Please read this manual carefully before using your **DS801-111**. Keep this manual handy for future reference. These safety instructions are to ensure the long life of your **DS801-111** and to prevent fire and shock hazards. Please read them carefully and heed all warnings.

### 1.1 GENERAL

- Qualified ALTINEX service personnel or their authorized representatives must perform all service.

### 1.2 INSTALLATION

- To prevent fire or shock, do not expose this unit to water or moisture. Do not place the **DS801-111** in direct sunlight, near heaters, or heat-radiating appliances, or near any liquid. Exposure to direct sunlight, smoke, or steam can harm internal components.
- Handle the **DS801-111** carefully. Dropping or jarring can damage the unit.
- Do not pull any cables that are attached to the **DS801-111**.

### 1.3 CLEANING

- Clean only with a dry cloth. Never use strong detergents or solvents, such as alcohol or thinner. Do not use a wet cloth or water to clean the unit. Do not open the unit to clean.

### 1.4 FCC NOTICE

- This device complies with Part 15 of the FCC Rules. Operation is subject to the following two conditions: (1) This device may not cause harmful interference; and (2) this device must accept any interference received, including interference that may cause undesired operation.
- This equipment has been tested and found to comply with the limits for a Class A digital device pursuant to Part 15 of the FCC Rules. These limits are designed to provide reasonable protection against harmful interference when the equipment is operated in a commercial environment. This equipment generates, uses, and can radiate radio frequency energy and if not installed and used in accordance with the instructions found herein, may cause harmful interference to radio communications. Operation of this equipment in a residential area is likely to cause harmful interference in which case the user will be required to correct the interference at his own expense.
- Any changes or modifications to the unit not expressly approved by ALTINEX, Inc. could void the user's authority to operate the equipment.

## ABOUT YOUR DS801-111

2

### DS801-111

#### Intera Twisted Pair (UTP) to Video + Stereo Audio Receiver

The **DS801-111** provides a means of receiving computer video and audio signals over Twisted Pair-type (CAT-5/6) cable when used together with a compatible ALTINEX Twisted Pair (UTP) video transmitter, such as the DS801-110 or DA1930CT.

The **DS801-111** is compact and easy to use. The **DS801-111** is able to receive either computer video or component video along with stereo audio transmitted over the UTP cable from the DS801-110 or an equivalent transmitter.

The **DS801-111** provides both video and stereo audio outputs. The **DS801-111** offers a female 15-pin HD output for RGBHV/YPbPr signals with native Plug & Play compatibility and a 3.5 mm jack is used for the stereo audio output.

The unit also offers video equalization hardware for long transmission lengths. There is also a Signal Detect feature that shows when an input signal is present.

The latest generation of Twisted Pair devices uses an innovative, patented technology\* developed by ALTINEX. The new signal processing technology allows transmitting and receiving fully equalized computer video signals, stereo, and audio signals over long distances.

\* US Patent 7,065,190

## TECHNICAL SPECIFICATIONS

3

Specifications are subject to change.  
See [www.altinex.com](http://www.altinex.com) for up-to-date information.

FEATURES/ DESCRIPTION	DS801-111
<b>GENERAL</b>	
<b>Inputs</b>	
Video+ Stereo Audio	RJ-45 female (1)
Power	2-pin terminal block (1)
<b>Output</b>	
Video	15-pin HD female (1)
Stereo Audio	3.5 mm female (1)
<b>Compatibility</b>	
Signal Types	ALTINEX Standard for Twisted Pair
Video Signal Resolutions	VGA through UXGA 480p through 1080i
Recommended Max. Cable Lengths <i>Note: Measurements made using ALTINEX low-skew cable, CB3150PV.</i>	VGA: 640x480@60Hz 900 ft (274 m) XGA: 1024x768@60Hz 700 ft (213 m) SXGA: 1280x1024@60Hz 650 ft (198 m) UXGA: 1600x1200@60Hz 600 ft (183 m)
<b>Accessories Included</b>	
Power Adapter (with 50 ft (15 m) cable)	+9 VDC, 1.1 A

Table 1. **DS801-111** General

# SPECIAL APPLICATION

MECHANICAL	DS801-111
Housing	0.036 in Aluminum
Front Panel	0.035 in Steel
Length	4.100 in (104 mm)
Width	1.380 in (35 mm)
Height	1.200 in (30 mm)
Weight	0.25 lb (0.11 kg)
T° Operating	10°C-50°C
T° Maximum	75°C
Humidity	90% non-condensing
MTBF (calc.)	38,000 hrs

Table 2. **DS801-111** Mechanical

ELECTRICAL	DS801-111
<b>Input</b>	
Video+ Stereo Audio	Video/Sync/Audio Signals ALTINEX Standard
<b>Output</b>	
Video Analog Signal	1.0 Vp-p max.
Video Sync Level	TTL
Audio Level	0 dB +/- 0.5 dB at 1 KHz
<b>Power Consumption</b>	
External Adapter: 9 VDC	410 mA (3.7 W) max.

Table 3. **DS801-111** Electrical

# SPECIAL APPLICATION

## PRODUCT DESCRIPTION

4

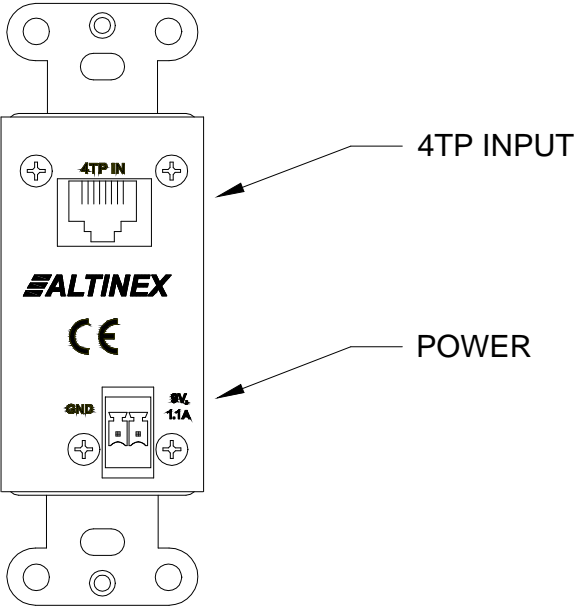
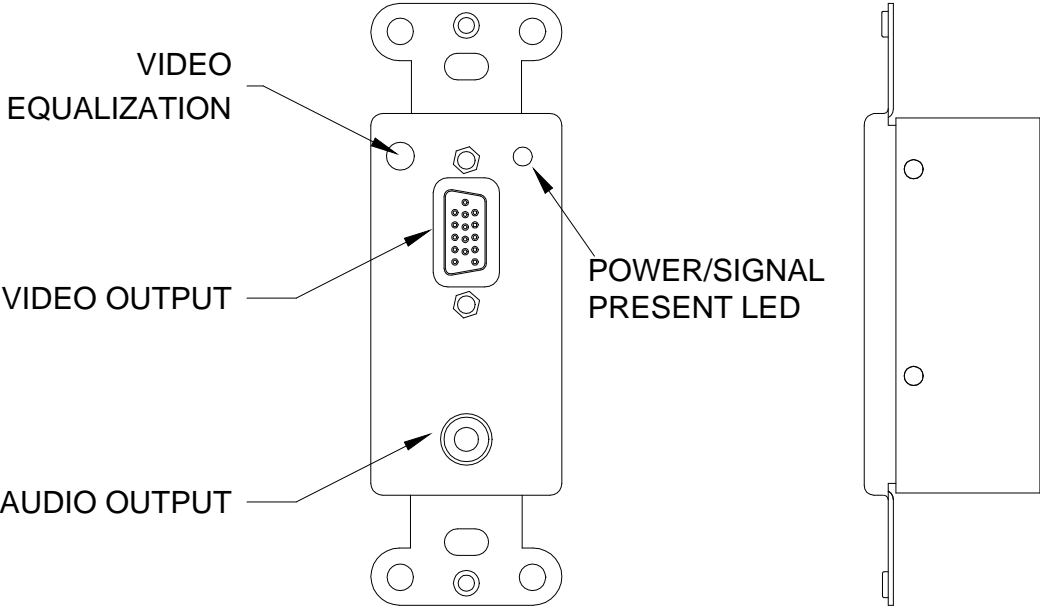

**APPLICATION DIAGRAMS**

**5**

**DIAGRAM 1: TYPICAL SETUPS**

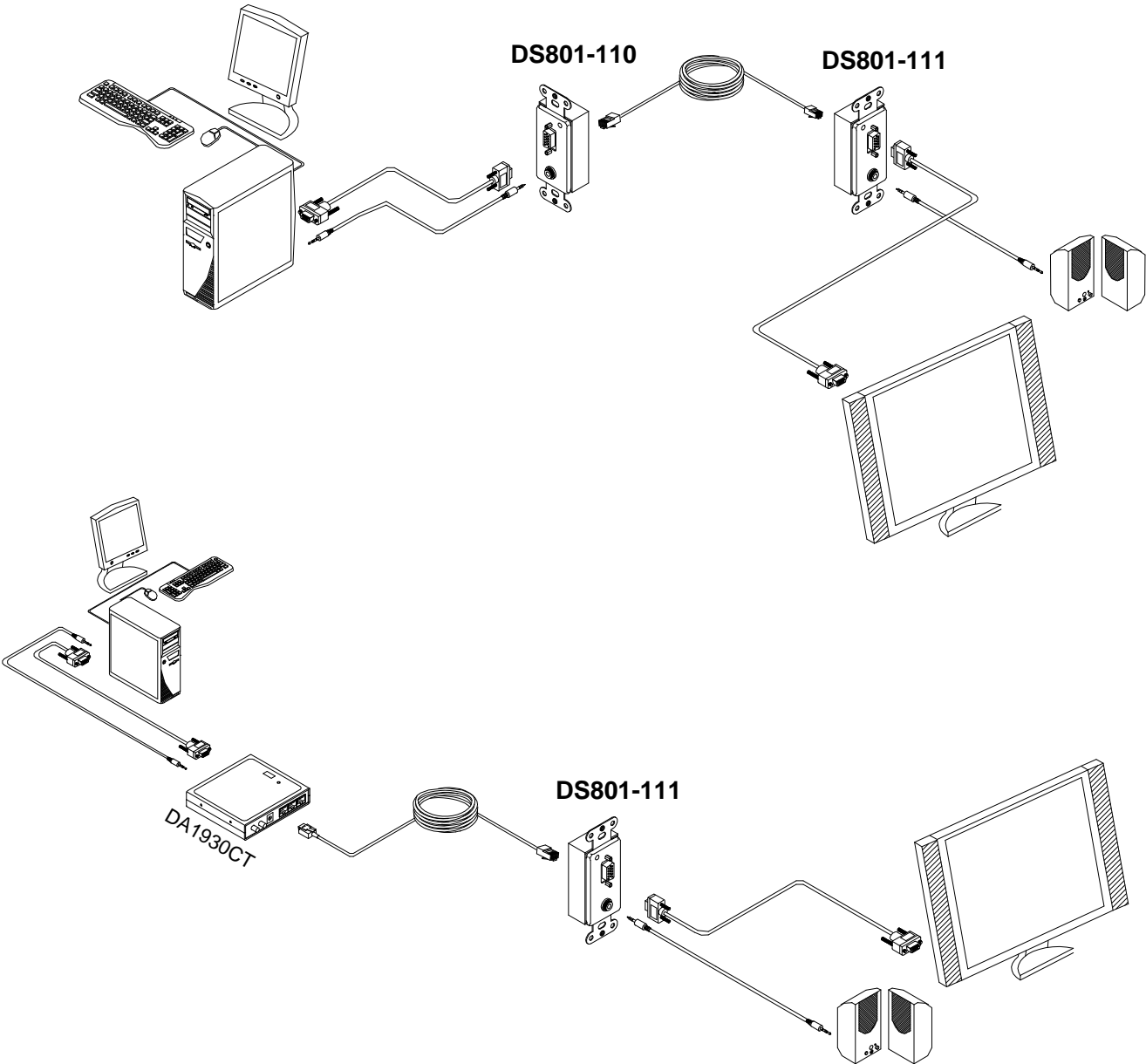

# SPECIAL APPLICATION

**DIAGRAM 2: INTERNAL VIEW**

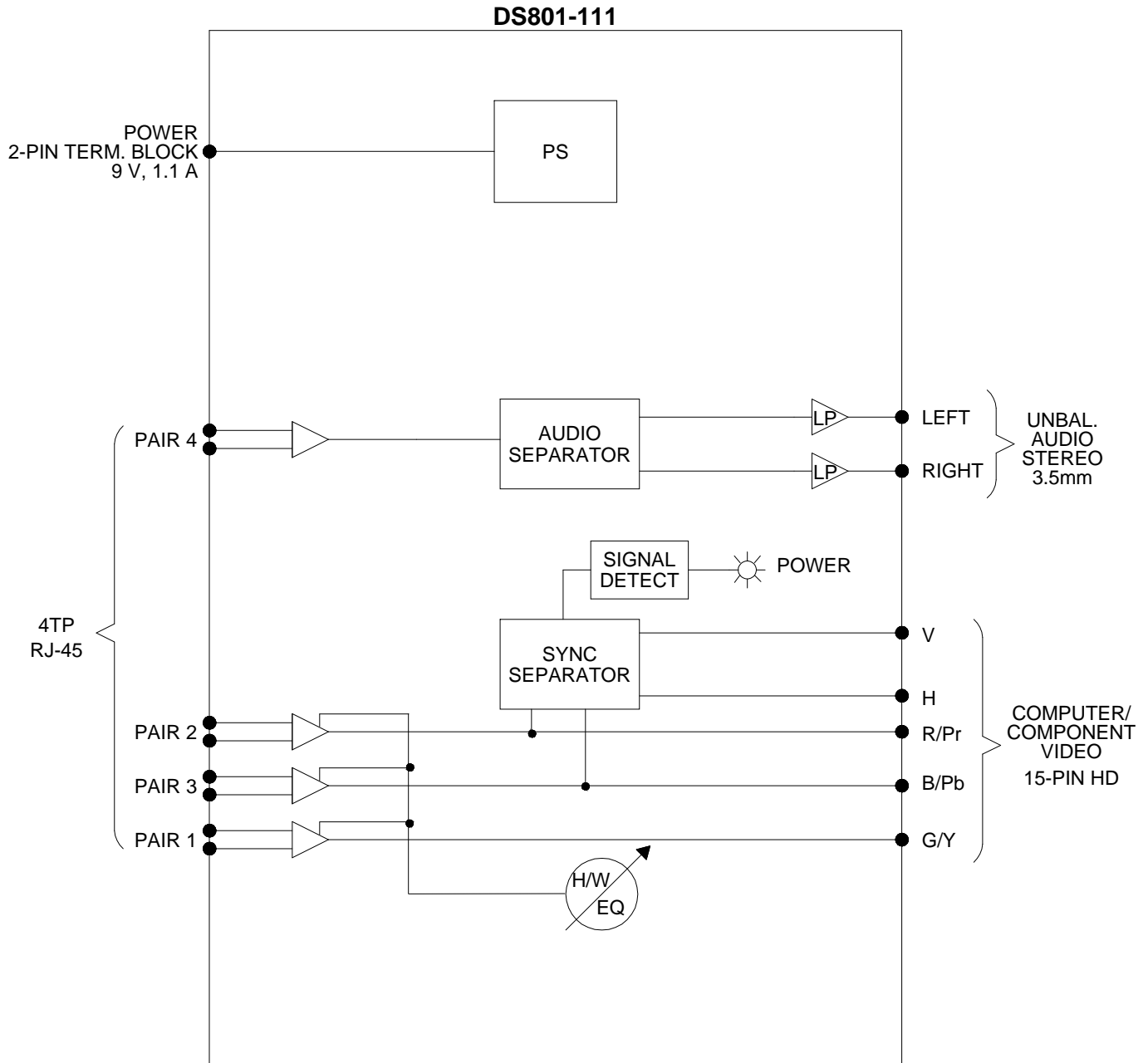



## INSTALLING YOUR DS801-111 6

- Step 1.** Determine the best location for the **DS801-111**. Where possible, locate the TP Transmitter as close to the video source as possible and the **DS801-111** as close to the receiving component as feasible.
- Step 2.** Apply power to the 2-pin terminal block on the rear of the **DS801-111**. The Power/Signal Present LED should be on and red.
- Step 3.** Connect the receiving display to the output of the **DS801-111** using a high-quality video cable.
- Step 4.** Connect the audio amplifier or speakers to the audio jack on the **DS801-111**.
- Step 5.** Run a UTP-type (CAT-5/CAT-5e) cable from the 4TP INPUT on the **DS801-111** Receiver to the 4TP OUTPUT on the TP Transmitter.
- NOTE: Ensure good signal transmission by routing the cable to avoid any sharp angles, creases, or bends.
- Step 6.** Connect the TP Transmitter per its installation instructions. In the case of the **DS801-111**, when the TP signal from the DS801-110 is applied, the Power/Signal Present LED will turn from red to green indicating a signal is present.
- Step 7.** The units are now operational.

## OPERATION 7

The **DS801-111** requires only one adjustment to be made for optimal performance. The adjustment is video equalization for long cable lengths.

### 7.1 VIDEO EQUALIZATION

Video equalization is provided to fine-tune the displayed image on the remote display. Typically, for short cable runs the equalization will be set to near minimum.

Start by setting the equalization to minimum on both units. Adjust the equalization on the receiver first. This adjustment should at least allow the receiving display to receive an image. Then use the equalization on both units to fine-tune the image for optimal quality.

## TROUBLESHOOTING GUIDE 8

We have carefully tested and have found no problems in the supplied **DS801-111**. However, we would like to offer suggestions for the following:

### 8.1 NO DISPLAY

**Cause 1: The source has a problem.**

*Solution:* Check the source and make sure there is a signal present and all source connections are correct. If the source is working and there is still no display, see Cause 2.

**Cause 2: The path has a problem.**

*Solution:* Connect the transmitter directly to the receiver using a short UTP patch cable. If the image is good, there is a problem with the cable. Otherwise, see Cause 3.

**Cause 3: Cable connections are incorrect.**

*Solution:* Make sure that cables are properly connected. Also, make sure that the continuity and wiring are good. If there is still no display present, see Cause 4.

**Cause 4: Video equalization required.**

*Solution:* Adjust the VIDEO EQUALIZATION on the **DS801-111**.

Some monitors are very sensitive to signal quality and this may prevent the monitor from displaying an image until the equalization is adjusted. See the operation section for adjustment details.

**Cause 5: The display has a problem.**

*Solution:* Make sure the display is powered and is turned on. If there is still no display, please call ALTINEX at (714) 990-2300.

## 8.2 NO SOUND

**Cause 1: The source has a problem.**

*Solution:* Check the source and make sure that there is a signal present and all source connections are correct. If the source is working and there is still no sound, see Cause 2.

**Cause 2: The volume is too low.**

*Solution:* Increase the gain at the source. If there is still no sound present, see Cause 3.

**Cause 3: Cable connections are incorrect.**

*Solution:* Make sure that cables are properly connected. Also, make sure that the continuity and wiring are good. If there is still no sound, see Cause 4.

**Cause 4: The receiving device has a problem.**

*Solution:* Make sure the receiving device is powered and is turned on. If there is still no sound, please call ALTINEX at (714) 990-2300.

## ALTINEX POLICIES

9

### 9.1 LIMITED WARRANTY/RETURN POLICIES

Please see the ALTINEX website at [www.altinex.com](http://www.altinex.com) for details on warranty and return policies.

### 9.2 CONTACT INFORMATION

ALTINEX, Inc.

592 Apollo Street

Brea, CA 92821 USA

**TEL:** 714 990-2300

**TOLL FREE:** 1-800-ALTINEX

**WEB:** [www.altinex.com](http://www.altinex.com)

**E-MAIL:** [solutions@altinex.com](mailto:solutions@altinex.com)