



VERSA PRO

FLAIL MOWER

Published 03/09

Part No. 803350C

OPERATOR'S MANUAL



This Operator's Manual is an integral part of the safe operation of this machine and must be maintained with the unit at all times. READ, UNDERSTAND, and FOLLOW the Safety and Operation Instructions contained in this manual before operating the equipment. *C01-Cover*

FC-FL-0010

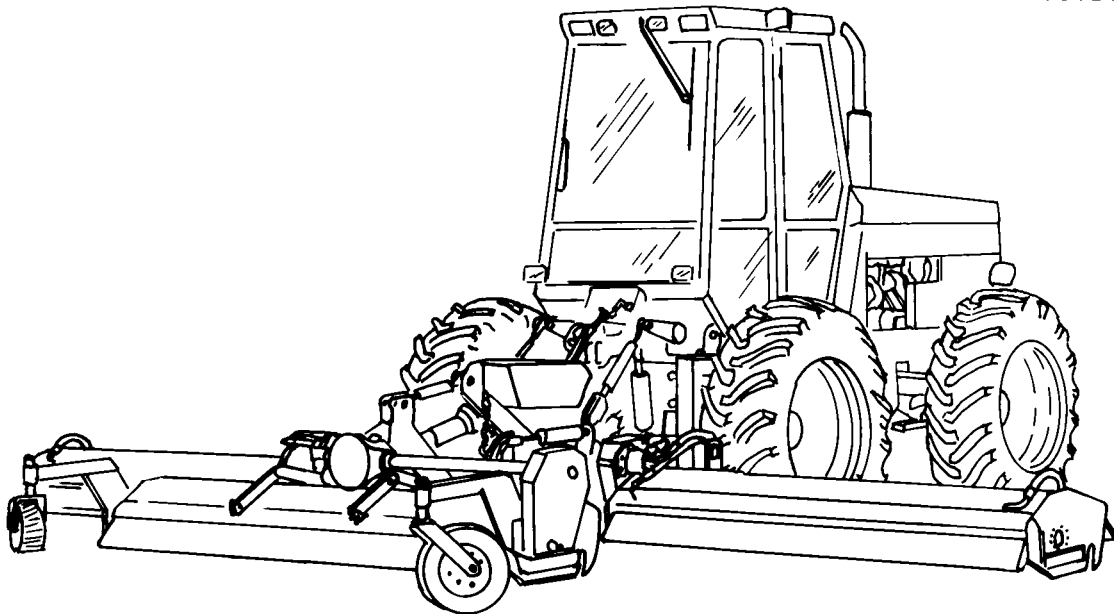

ALAMO INDUSTRIAL®

1502 E. Walnut
Seguin, Texas 78155
830-372-3551
Email: parts@alamo-industrial.com



To the Owner/Operator/Dealer

All implements with moving parts are potentially hazardous. There is no substitute for a cautious, safe-minded operator who recognizes the potential hazards and follows reasonable safety practices. The manufacturer has designed this implement to be used with all its safety equipment properly attached to minimize the chance of accidents.

BEFORE YOU START!! Read the safety messages on the implement and shown in your manual. Observe the rules of safety and common sense!

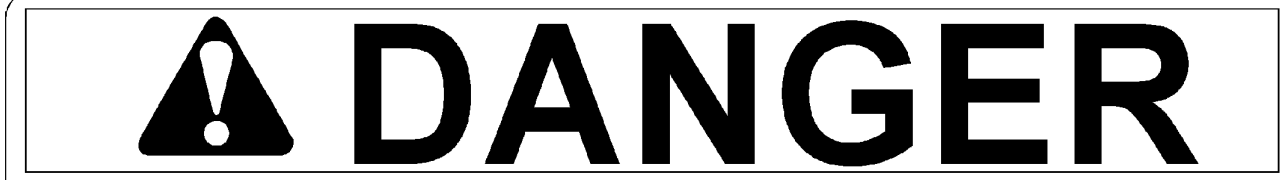

FAILING TO FOLLOW SAFETY MESSAGES AND OPERATING INSTRUCTIONS CAN CAUSE SERIOUS BODILY INJURY OR EVEN DEATH TO OPERATOR AND OTHERS IN THE AREA.

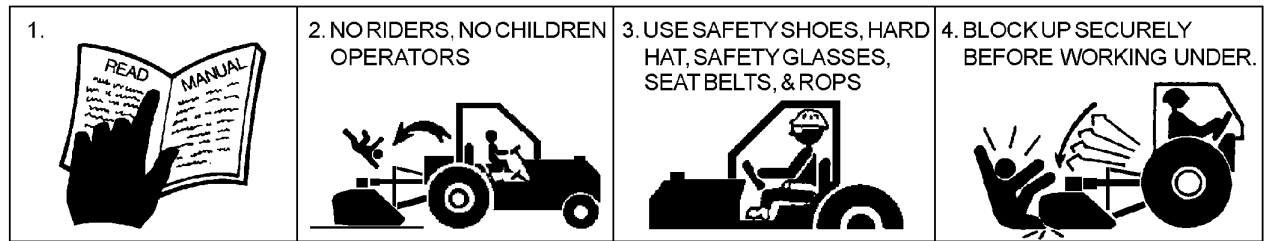

1. Study and understand Operator's Manuals, Safety Signs, and Instructional Decals for tractor & flail mower to prevent misuse, abuse, & accidents. Practice before operating mower in a confined area or near passersby.
 - Learn how to stop engine suddenly in an emergency. Be alert for passersby and especially children.
2. Allow no children on or near implement or tractor. Allow no riders on tractor or implement. Falling off can cause serious injury or death from being runover by tractor or mower or contact with Flail Mower Blades.
3. Operate only with tractor having Roll-Over Protective Structure (ROPS) and with seatbelt fastened securely and snugly to prevent injury and possible death from falling off or tractor overturn. Personal Protective Equipment such as Hard Hat, Safety Glasses, Safety Shoes, and Ear Plugs are recommended.
4. Block up or support raised machine and all lifted components securely before putting hands or feet under or working underneath any lifted component to prevent crushing injury or death from sudden dropping or inadvertent operation of controls. Make certain that area is clear before lowering or folding.
5. Before transporting, put Lift Lever in detent or full-lift position. Install Transport Safety Devices securely on folding implements. Slow down when turning and on hillsides.
 - Install **Restrictor in folding circuit to slow down lowering and unfolding if action is faster than is desirable.
6. Make certain that SMV sign, Warning Lights, and Reflectors are clearly visible. Follow local traffic codes.
7. Never operate with Flail Mower or Folding Section raised if passersby, bystanders or traffic are in the area to reduce possibility of injury or death from objects thrown by Blades under Shields or implement structure.
8. Before dismounting, secure flail mower in transport position or lower to ground.
 - Put tractor in park or set brake, disengage PTO, stop engine, remove key, and wait until noise of rotation has ceased to prevent entanglement in rotating parts which may cause injury or death.
 - Never mount or dismount a moving vehicle. Crushing from runover may cause injury or death.

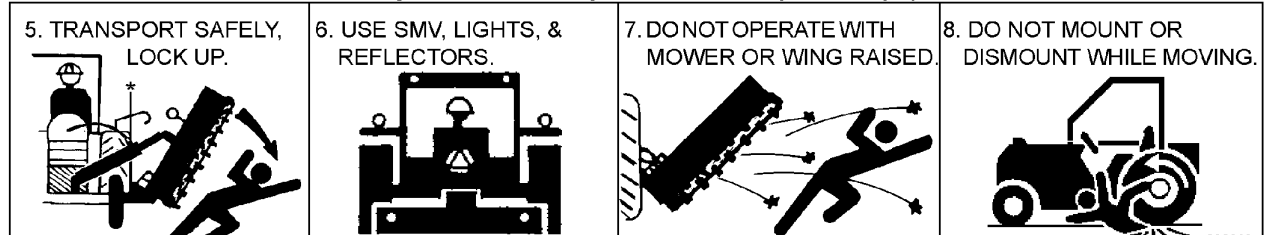

WARRANTY INFORMATION:

Read and understand the complete Warranty Statement found in this Manual. Fill out the Warranty Registration Form in full and return it to within 30 Days. Make certain the Serial Number of the Machine is recorded on the Warranty Card and on the Warranty Form that you retain.

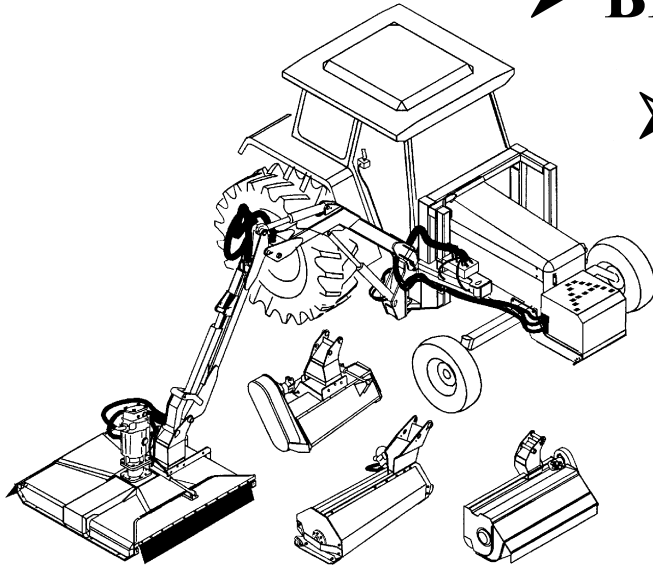

➤ **BE SAFE!**

➤ **BE ALERT!**

➤ **BE ALIVE!**

➤ **BE TRAINED
before operating
the Mower!**

**ALAMO
INDUSTRIAL**

*Safety Training
Makes the Difference*

In order to reduce accidents and enhance the safe operation of mowers, *Alamo Industrial*, in cooperation with other industry manufacturers has developed the AEM/FEMA Industrial and Agricultural Mower Safety Practices video and guide book.

The video will familiarize and instruct mower-tractor operators in safe practices when using industrial and agricultural mowing equipment. It is important that Every Mower Operator be educated in the operation of their mowing equipment and be able to recognize the potential hazards that can occur while operating a mower. This video, along with the mower operator's manual and the warning messages on the mower, will significantly assist in this important education.

Your Authorized *Alamo Industrial* Dealer may have shown this video and presented you a DVD Video when you purchased your mower. If you or any mower operator have not seen this video, **Watch the Video, Read this Operator's Manual, and Complete the Video Guidebook** before operating your new mower. If you do not understand any of the instructions included in the video or operator's manual or if you have any questions concerning safety of operation, contact your supervisor, dealer or *Alamo Industrial*.

If you would like a VHS video tape of the video, please email AEMVideo@alamo-group.com or Fax AEM VHS Video at (830) 372-9529 or mail in a completed copy of the form on the back of this page to AEM VHS Video 1502 E Walnut Street, Seguin, TX 78155. and request the VHS video version. Please include your name, mailing address, mower model and serial number.

Every operator should be trained for each piece of equipment (Tractor and Mower), understand the intended use, and the potential hazards before operating the equipment.

**Alamo Industrial Division is willing to provide
one (1) AEM Mower Safety Practices Video**

- Please Send Me: VHS Format – AEM/FEMA Mower Operator Safety Video
 DVD Format – AEM/FEMA Mower Operator Safety Video
 Mower Operator’s Manual
 AEM Mower Operator’s Safety Manual

Requester Name _____ Phone: _____

Requester Address: _____

City _____

State _____

Zip Code _____

Mower Model: _____ Serial Number: _____

Date Purchased: _____ Dealer Salesperson: _____

Dealership Name: _____ Dealership Location: _____

Mail to:

AEM Video Services

1502 E Walnut street

Seguin, TX 78155

Or Fax to:

(830) 372-9529

Or Email to:

AEMVideo@alamo-group.com

TABLE OF CONTENTS

SAFETY SECTION	1-1
General Safety Instructions and Practices	1-2
Operator Safety Instructions and Practices	1-3
Equipment Operation Safety Instructions and Practices	1-5
Transporting Safety Instructions and Practices	1-11
Concluding Safety Instructions and Practices	1-15
Decal Location	1-16
Decal Description	1-18
Federal Laws and Regulations	1-27
INTRODUCTION SECTION	2-1
ASSEMBLY SECTION	3-1
TRACTOR PREPARATION	3-2
MAINFRAME TO ATTACHMENT FRAME ASSEMBLY	3-3
TRACTOR TO ATTACHMENT FRAME ASSEMBLY	3-4
DRIVELINE ATTACHMENT	3-5
CENTER & WING MOWER ASSEMBLY	3-5
WING MOWER ATTACHMENT	3-6
LIFT FRAME TO MOWER	3-6
ELECTRICAL CONNECTION AT TRACTOR	3-7
ELECTRICAL CONNECTION AT MOWER	3-7
CENTER MOWER ASSEMBLY	3-8
CENTER MOWER ASSEMBLY	3-9
CENTER MOWER ASSEMBLY	3-10
INSTALLATION OF CENTER MOWER	3-11
HYDRAULIC CONNECTIONS	3-12
HOSE CONNECTION AT TRACTOR	3-13
HYDRAULIC CONNECTIONS TO CYLINDER	3-14
HYDRAULIC CONNECTIONS TO FILTER	3-14
HYDRAULIC CONNECTIONS TO PUMP	3-14
HYDRAULIC CONNECTION MOTORS	3-15
Left Wing Hydraulic Motor	3-15
Right Wing Hydraulic Motor	3-15
HYDRAULIC	3-16
FINAL CHECK	3-16
OPERATION SECTION	4-1
OPERATOR REQUIREMENTS	4-4
ROPS and Seat Belt	4-5
Tractor Safety Devices	4-5
Tractor Horsepower	4-6
Tractor Hydraulics	4-6
Front End Weight	4-6
Power Take Off (PTO)	4-6
GETTING ON AND OFF THE TRACTOR	4-7
Boarding the Tractor	4-7
Dismounting the Tractor	4-7

STARTING THE TRACTOR	4-8
SETTING THE MOWER	4-9
DRIVELINE ATTACHMENT	4-11
Driveline Length Check	4-11
PRE-OPERATION INSPECTION AND SERVICE	4-13
Mower Pre-Operation Inspection/Service	4-13
Tractor Pre-Operation Inspection/Service	4-14
DRIVING THE TRACTOR AND IMPLEMENT	4-20
Starting the Tractor	4-21
Brake and Differential Lock Setting	4-22
Operating the Mower Wing	4-22
Driving the Tractor and Implement	4-24
Crossing Ditches and Steep Inclines	4-24
OPERATING THE TRACTOR AND IMPLEMENT	4-26
Foreign Debris Hazard	4-27
Bystander/Passersby Precautions	4-28
Engaging the Power to Take Off (PTO)	4-28
PTO RPM and Ground Speed	4-29
Operating the Mower	4-29
Shutting Down the Implement	4-31
DISCONNECTING THE MOWER FROM THE TRACTOR	4-31
MOWER STORAGE	4-33
TRANSPORTING THE TRACTOR AND IMPLEMENT	4-33
Transporting on Public Roadways	4-35
Hauling the Tractor and Implement	4-37
TROUBLESHOOTING GUIDE	4-38

MAINTENANCE SECTION 5-1

DAILY CHECKS	5-2
LUBRICATION INFORMATION	5-3
CHANGING HYDRAULIC SYSTEM FILTER	5-4
GENERAL	5-7
REPLACING CUTTER UNIT DRIVE BELTS	5-7
ADJUSTING CUTTING HEIGHT	5-7
ROLLER BEARING REPLACEMENT	5-8
CUTTERSHAFT BEARING REPLACEMENT	5-9
Changing to Forward or Reverse Rotation	5-11
Replacing Cutter Unit Knives	5-11
HYDRAULICS	5-12
GENERAL	5-12
INITIAL START-UP PROCEDURES	5-12
HYDRAULIC PUMPS	5-12
REPLACING HYDRAULIC PUMPS	5-13
RESERVOIR	5-14
SOLENOID CONTROL VALVE	5-14
CHECKING SOLENOID VALVE	5-15
HYDRAULIC	5-15
DISASSEMBLY	5-15
REASSEMBLY	5-16
HYDRAULIC MOTOR	5-17
DISASSEMBLY	5-17
REASSEMBLY	5-18
LIFT CYLINDERS	5-19
DISASSEMBLY OF LIFT CYLINDER	5-19

EXTERNAL COIL SLIP CLUTCH DISK REPLACEMENT	5-20
TO DISASSEMBLE EXTERNAL COIL SPRING CLUTCH	5-20
TO CLEAN AND INSPECT	5-20
TO REASSEMBLE	5-20
TO ADJUST	5-20
MACHINE IS STORED OUTSIDE FOR 30 DAYS OR MORE	5-22
VERSA PRO TANK FILLING INSTRUCTIONS	5-23
Cylinder Rod Maintenance	5-23
STORAGE	5-24
PROPER TORQUE FOR FASTENERS	5-24

SAFETY SECTION

Safety Section 1-1

SAFETY

General Safety Instructions and Practices

A careful operator is the best operator. Safety is of primary importance to the manufacturer and should be to the owner/operator. Most accidents can be avoided by being aware of your equipment, your surroundings, and observing certain precautions. The first section of this manual includes a list of Safety Messages that, if followed, will help protect the operator and bystanders from injury or death. Read and understand these Safety Messages before assembling, operating or servicing this Implement. This equipment should only be operated by those persons who have read the manual, who are responsible and trained, and who know how to do so responsibly.



The Safety Alert Symbol combined with a Signal Word, as seen below, is used throughout this manual and on decals which are attached to the equipment. The Safety Alert Symbol means: "ATTENTION! BECOME ALERT! YOUR SAFETY IS INVOLVED!" The Symbol and Signal Word are intended to warn the owner/operator of impending hazards and the degree of possible injury faced when operating this equipment.

Practice all usual and customary safe working precautions and above all---remember safety is up to YOU. Only YOU can prevent serious injury or death from unsafe practices.



Indicates an imminently hazardous situation that, if not avoided, WILL result in DEATH OR VERY SERIOUS INJURY.



Indicates an imminently hazardous situation that, if not avoided, COULD result in DEATH OR SERIOUS INJURY.



Indicates an imminently hazardous situation that, if not avoided, MAY result in MINOR INJURY.



Identifies special instructions or procedures that, if not strictly observed, could result in damage to, or destruction of the machine, attachments or the environment.

NOTE: *Identifies points of particular interest for more efficient and convenient operation or repair.* (SG-1)

READ, UNDERSTAND, and FOLLOW the following Safety Messages. Serious injury or death may occur unless care is taken to follow the warnings and instructions stated in the Safety Messages. Always use good common sense to avoid hazards. (SG-2)



Si no lee ingles, pida ayuda a alguien que si lo lea para que le traduzca las medidas de seguridad. (SG-3)

¡ LEA EL INSTRUCTIVO!



SAFETY



Engine Exhaust, some of its constituents, and certain vehicle components contain or emit chemicals known to the state of California to cause cancer and birth defects or other reproductive harm. (SG-30)



Battery posts, terminals and related accessories contain lead and lead compounds, chemicals known to the state of California to cause cancer, birth defects or other reproductive harm. (SG-31)

Operator Safety Instructions and Practices



The rotating parts of this machine continue to rotate even after the PTO has been turned off. The operator should remain in his seat for 60 seconds after the brake has been set, the PTO disengaged, the tractor turned off, and all evidence of rotation has ceased. (S3PT-10)

“Wait a minute...Save a life!”



Never crawl under a raised Implement supported solely by the Tractor 3-Point hitch. Release of the control lever or mechanical failure will result in the Implement falling and possible injury or death. Always securely block up the Implement before crawling underneath to perform repairs and service. (S3PT-19)



Never operate the Tractor or Implement until you have read and completely understand this Manual, the Tractor Operator's Manual, and each of the Safety Messages found in the Manual or on the Tractor and Implement. Learn how to stop the tractor engine suddenly in an emergency. Never allow inexperienced or untrained personnel to operate the Tractor and Implement without supervision. Make sure the operator has fully read and understood the manuals prior to operation. (SG-4)

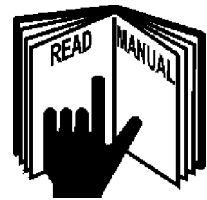

The operator and all support personnel should wear hard hats, safety shoes, safety glasses, and proper hearing protection at all times for protection from injury including injury from items that may be thrown by the equipment. (SG-16)

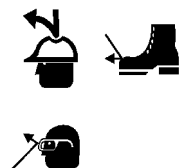

SAFETY

CAUTION

PROLONGED EXPOSURE TO LOUD NOISE MAY CAUSE PERMANENT HEARING LOSS! Tractors with or without an Implement attached can often be noisy enough to cause permanent hearing loss. We recommend that you always wear hearing protection if the noise in the Operator's position exceeds 80db. Noise over 85db over an extended period of time will cause severe hearing loss. Noise over 90db adjacent to the Operator over an extended period of time will cause permanent or total hearing loss. **NOTE:** *Hearing loss from loud noise [from tractors, chain saws, radios, and other such sources close to the ear] is cumulative over a lifetime without hope of natural recovery.* (SG-17)



WARNING

Always read carefully and comply fully with the manufacturer's instructions when handling oil, solvents, cleansers, and any other chemical agent. (SG-22)



DANGER

KEEP AWAY FROM ROTATING ELEMENTS to prevent entanglement and possible serious injury or death. (SG-24)



DANGER

Never allow children to play on or around Tractor or Implement. Children can slip or fall off the Equipment and be injured or killed. Children can cause the Implement to shift or fall crushing themselves or others. (SG-25)

DANGER

NEVER use drugs or alcohol immediately before or while operating the Tractor and Implement. Drugs and alcohol will affect an operator's alertness and coordination and therefore affect the operator's ability to operate the equipment safely. Before operating the Tractor or Implement, an operator on prescription or over-the-counter medication must consult a medical professional regarding any side effects of the medication that would hinder their ability to operate the Equipment safely. NEVER knowingly allow anyone to operate this equipment when their alertness or coordination is impaired. Serious injury or death to the operator or others could result if the operator is under the influence of drugs or alcohol. (SG-27)



WARNING

Prolonged operation may cause operator boredom and fatigue affecting safe operation. Take scheduled work breaks to help prevent these potentially impaired operating conditions. Never operate the Implement and Tractor in a fatigued or bored mental state which impairs proper and safe operation. (SG-32)

SAFETY



WARNING

Use extreme caution when getting onto the Implement to perform repairs, maintenance and when removing accumulated material. Only stand on solid flat surfaces to ensure good footing. Use a ladder or raised stand to access high spots which cannot be reached from ground level. Slipping and falling can cause serious injury or death. (SG-33)



WARNING

Avoid contact with hot surfaces including hydraulic oil tanks, pumps, motors, valves and hose connections. Relieve hydraulic pressure before performing maintenance or repairs. Use gloves and eye protection when servicing hot components. Contact with a hot surface or fluid can cause serious injury from burns or scalding. (SG-34)



DANGER

DO NOT operate this Implement on a Tractor that is not properly maintained. Should a mechanical or Tractor control failure occur while operating, immediately shut down the Tractor and perform repairs before resuming operation. Serious injury and possible death could occur from not maintaining this Implement and Tractor in good operating condition. (SG-36)



WARNING

Avoid contact with hot surfaces of the engine or muffler. Use gloves and eye protection when servicing hot components. Contact with a hot surface or fluid can cause serious injury from burns or scalding. (SG-38)



WARNING

Do not put hands or feet under mower decks. Blade Contact can result in serious injury or even death. Stay away until all motion has stopped and the decks are securely blocked up. (SGM-09)

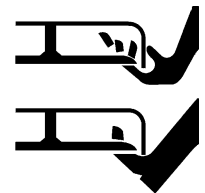

DANGER

Always keep a careful lookout and use extreme care when working around utility and municipal obstructions. Never allow the Mower to contact any utility, municipal, or other type structure. Clearly mark all mowing obstructions and consult local utility providers for a safe code of operation. (SPU-5)



DANGER

Do not operate the implement while wearing loose fitting clothing. Entanglement of the clothing with the rotating elements can result in serious injury or even death. Stay clear of all rotating elements at all times. (SSP-03)

Equipment Operation Safety Instructions and Practices



WARNING

Never leave the Tractor and Implement unattended while the Implement is in the lifted position. Accidental operation of lifting lever or a hydraulic failure may cause sudden drop of unit with injury or death by crushing. To properly park the implement when disconnecting it from the tractor, lower the stand and put the retaining pin securely in place, or put a secure support under the A-Frame. Lower the implement carefully to the ground. Do not put hands or feet under lifted components. (S3PT-1)

SAFETY

SAFETY



Use extreme care when lowering or unfolding the implement's wings. Make sure no bystanders are close by or underneath the wings. Allow ample clearance around the implement when folding or unfolding the wings. Use extreme caution around buildings or overhead power lines. (S3PT-05)



This Implement is wider than the Tractor. Be careful when operating or transporting this equipment to prevent the Implement from running into or striking sign posts, guard rails, concrete abutments or other solid objects. Such an impact could cause the Implement and Tractor to pivot violently resulting in loss of steering control, serious injury, or even death. Never allow the Implement to contact obstacles. (S3PT-12)



Be sure you have adequate knowledge of the property you will be working on. Take time to make yourself aware of any area underground lines or cables. Contact with buried lines or cable could result in **serious injury or death**. If in doubt about buried utility lines call 811 before digging or 1-800-258-0808. (SBH-6)



Do not operate Mower if excessive vibration exists. Shut down PTO and the Tractor engine. Inspect the Mower to determine the source of the vibration. If Mower blades are missing or damaged replace them immediately. Do not operate the mower until the blades have been replaced and the Mower operates smoothly. Operating the Mower with excessive vibration can result in component failure and broken objects to be thrown outward at very high velocities. To reduce the possibility of property damage, serious injury, or even death, never allow the Mower to be operated with blades missing. (SFL-4)



Operate this Equipment only with a Tractor equipped with an approved roll-over-protective system (ROPS). Always wear seat belts. Serious injury or even death could result from falling off the tractor--particularly during a turnover when the operator could be pinned under the ROPS. (SG-7)



BEFORE leaving the tractor seat, always engage the brake and/or set the tractor transmission in parking gear, disengage the PTO, stop the engine, remove the key, and wait for all moving parts to stop. Place the tractor shift lever into a low range or parking gear to prevent the tractor from rolling. Never dismount a Tractor that is moving or while the engine is running. Operate the Tractor controls from the tractor seat only. (SG-9)

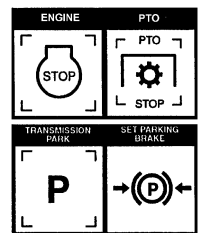

Never allow children or other persons to ride on the Tractor or Implement. Falling off can result in serious injury or death. (SG-10)



SAFETY

DANGER

Never allow children to operate, ride on, or come close to the Tractor or Implement. Usually, 16-17 year-old children who are mature and responsible can operate the implement with adult supervision, if they have read and understand the Operator's Manuals, been trained in proper operation of the tractor and Implement, and are physically large enough to reach and operate the controls easily. (SG-11)



WARNING

Do not mount or dismount the Tractor while the tractor is moving. Mount the Tractor only when the Tractor and all moving parts are completely stopped. (SG-12)



DANGER

Start tractor only when properly seated in the Tractor seat. Starting a tractor in gear can result in injury or death. Read the Tractor operators manual for proper starting instructions. (SG-13)



WARNING

Do not operate this Equipment with hydraulic oil or fuel leaking. Oil and fuel are explosive and their presence could present a hazard. Do not check for leaks with your hand! High-pressure oil streams from breaks in the line could penetrate the skin and cause tissue damage including gangrene. To check for a hose leak, SHUT the unit ENGINE OFF and remove all hydraulic pressure. Wear oil impenetrable gloves, safety glasses and use Cardboard to check for evidence of oil leaks. If you suspect a leak, REMOVE the HOSE and have it tested at a Dealer. If oil does penetrate the skin, have the injury treated immediately by a physician knowledgeable and skilled in this procedure. (SG-15)



DANGER

Never run the Tractor engine in a closed building or without adequate ventilation. The exhaust fumes can be hazardous to your health. (SG-23)

WARNING

Do not exceed the rated PTO speed for the Implement. Excessive PTO speeds can cause Implement driveline or blade failures resulting in serious injury or death. (SG-26)

DANGER

Operate the Tractor and/or Implement controls only while properly seated in the Tractor seat with the seat belt securely fastened around you. Inadvertent movement of the Tractor or Implement may cause serious injury or death. (SG-29)

SAFETY

SAFETY

WARNING

In case of mechanical difficulty during operation, place the transmission in the park position, set the parking brake, shut down all power, including the PTO and the engine and remove the key. Wait until all rotating motion has stopped before dismounting. (SG-39)

WARNING

Do Not operate this equipment in areas where insects such as bees may attack you and/or cause you to lose control of the equipment. If you must enter in such areas, use a tractor with an enclosed Cab and close the windows to prevent insects from entering. If a tractor cab is not available, wear suitable clothing including head, face, and hand protection to shield you from the insects. Attacking insects can cause you to lose control of the tractor, which can result in serious injury or death to you or bystanders. Never dismount a moving tractor. (SG-40)

WARNING

Mow only in conditions where you have clear visibility in daylight or with adequate artificial lighting. Never mow in darkness or foggy conditions where you cannot clearly see at least 100 yards(90 m) in front and to the sides of the tractor and mower. Make sure that you can clearly see and identify passersby, steep slopes, ditches, drop-offs, overhead obstructions, power lines, debris and foreign objects. If you are unable to clearly see these type of items discontinue mowing. (SGM-1)

DANGER

There are obvious and hidden potential hazards in the operation of this Mower. REMEMBER! This machine is often operated in heavy brush and in heavy weeds. The Blades of this Mower can throw objects if shields are not properly installed and maintained. Serious injury or even death may occur unless care is taken to insure the safety of the operator, bystanders, or passersby in the area. Do not operate this machine with anyone in the immediate area. Stop mowing if anyone is within 100 yards of mower. (SGM-02)



DANGER

The rotating parts of this machine have been designed and tested for rugged use. However, the blades could fail upon impact with heavy, solid objects such as metal guard rails and concrete structures. Such impact could cause the broken objects to be thrown outward at very high velocities. To reduce the possibility of property damage, serious injury, or even death, never allow the cutting blades to contact such obstacles. (SGM-4)

WARNING

Extreme care should be taken when operating near loose objects such as gravel, rocks, wire, and other debris. Inspect the area before mowing. Foreign objects should be removed from the site to prevent machine damage and/or bodily injury or even death. Any objects that cannot be removed must be clearly marked and carefully avoided by the operator. Stop mowing immediately if blades strike a foreign object. Repair all damage and make certain rotor or blade carrier is balanced before resuming mowing. (SGM-05)



SAFETY

WARNING

Many varied objects, such as wire, cable, rope, or chains, can become entangled in the operating parts of the mower head. These items could then swing outside the housing at greater velocities than the blades. Such a situation is extremely hazardous and could result in serious injury or even death. Inspect the cutting area for such objects before mowing. Remove any like object from the site. Never allow the cutting blades to contact such items.

(SGM-06)

WARNING

Mow at the speed that you can safely operate and control the tractor and mower. The correct mowing speed depends on terrain condition and grass type, density, and height of cut. Normal ground speed range is from 2 to 5 mph(3-8 kph). Use slow mowing speeds when operating on or near steep slopes, ditches, drop-offs, overhead obstructions, power lines, or when debris and foreign objects are to be avoided. (SGM-07)

WARNING

Avoid mowing in reverse direction when possible. Check to make sure there are no persons behind the mower and use extreme care when mowing in reverse. Mow only at a slow ground speed where you can safely operate and control the tractor and mower. Never mow an area that you have not inspected and removed debris or foreign material.

(SGM-08)

WARNING

Do not mow with two machines in the same area except with Cab tractors with the windows closed. (SGM-11)

WARNING

Follow these guidelines to reduce the risk of equipment and grass fires while operating, servicing, and repairing the Mower and Tractor:

-Equip the Tractor with a fire extinguisher in an accessible location.



-Do Not operate the Mower on a Tractor with an underframe exhaust.

-Do Not smoke or have an open flame near the Mower and Tractor.

-Do Not drive into burning debris or freshly burnt areas.

-Ensure slip clutches are properly adjusted to prevent excessive slippage and plate heating.

-Never allow clippings or debris to collect near drivelines, slip clutches, and gearboxes. Periodically shut down the Tractor and Mower and clean clippings and collected debris from the mower deck. (SGM-12)

DANGER

The Mower is designed for certain mowing applications and is rated to cut up to a specific size vegetation (see Mower Standard Equipment and Specifications). DO NOT use this mower to cut vegetation above the Mower's rated capacity or to cut any type of non-vegetative material. Only operate this Mower on a properly sized and equipped Tractor. Operating this Mower in an application for which it is not designed and/or operating the Mower with the wrong size Tractor can cause Mower component damage and equipment failure resulting in possible serious injury or death. (SGM-14)

SAFETY

WARNING

Do not operate or pull the mower into standing water. When uplift or fan type mower blades contact water they can be severely deflected downward causing possible failure of blade resulting in serious injury to the operator or bystanders. (SGM-15)

DANGER

Use extreme caution when raising the Mower above ground level. Stop the Blades from turning when the Mower is raised and passersby are within 100 yards. Raising the Mower exposes the Cutting Blades which creates a potentially serious hazard and can cause serious injury by objects thrown from the Blades or by contact with the Blades. (SPU-1)

DANGER

Rotary Mowers are capable under adverse conditions of throwing objects for great distances (300 feet or more) and causing serious injury or death. Follow safety messages carefully.



STOP MOWING IF PASSERSBY ARE WITHIN 100 YARDS UNLESS:

- Front and Rear Deflectors, Chain Guards, or Bands are installed and in good, workable condition;
- Mower sections or Wings are running close to and parallel to the ground without exposed Blades;
- Passersby are outside the existing thrown-object zone;
- All areas have been thoroughly inspected and all foreign material such as rocks, cans, glass, and general debris has been removed.

NOTE: *Where there are grass and weeds high enough to hide debris that could be struck by the blades, the area should be: inspected and large debris removed, mowed at an intermediate height, inspected, closely with any remaining debris being removed, and mowed again at desired final height. (This will also reduce power required to mow, reduce wear and tear on the Mower drivetrain, spread cut material better, reduce streaking, and make the final cut more uniform).* (SRM-01)

DANGER

Do not turn so sharp or lift mower so high to produce a severe "knocking" of the Driveline which will cause accelerated wear and breakage of drive train components and could result in possible injury from the separated Driveline sections. (SRM-04)

WARNING

Do not let the Blades turn when the Mower Deck is raised for any reason, including clearance or for turning. Raising the Mower deck exposes the Cutting Blades which creates a potentially serious hazard and could cause serious injury or even death from objects thrown from the Blades. (SRM-07)



Connecting or Disconnecting Implement Safety Instructions and Practices

SAFETY



DO NOT use a PTO adapter to attach a non-matching Implement driveline to a Tractor PTO. Use of an adapter can double the operating speed of the Implement resulting in excessive vibration, thrown objects, and blade and implement failure. Adapter use will also change the working length of the driveline exposing unshielded driveline areas. Serious bodily injury and/or equipment failure can result from using a PTO adapter. Consult an authorized dealer for assistance if the Implement driveline does not match the Tractor PTO. (S3PT-14)



Always shut the Tractor completely down, place the transmission in park, and set the parking brake before you or anyone else attempts to connect or disconnect the Implement and Tractor hitches. (S3PT-15)



Never operate the Tractor and Mower if the Implement input driveline is directly connected to the Tractor transmission. Tractor braking distances can be substantially increased by the momentum of the rotating Mower blades driving the Tractor transmission even though the Tractor clutch has been disengaged. Install an over running clutch between the Tractor PTO and the Mower driveline to prevent this potentially dangerous situation. (S3PT-16)



When attaching the Implement input driveline to the Tractor PTO, it is important that the connecting yoke spring activated locking collar slides freely and the locking balls are seated securely in the groove on the Tractor PTO shaft. Push and pull the driveline back and forth several times to ensure it is securely attached. A driveline not attached correctly to the Tractor PTO shaft could come loose and result in personal injury and damage to the Implement. (S3PT-17)



Before operating the Implement, check to make sure the Implement input driveline will not bottom out or become disengaged. Bottoming out occurs when the inner shaft penetrates the outer housing until the assembly becomes solid-it can shorten no more. Bottoming out can cause serious damage to the Tractor PTO by pushing the PTO into the Tractor and through the support bearings or downward onto the PTO shaft, breaking it off. A broken driveline can cause personal injury. (S3PT-18)

Transporting Safety Instructions and Practices



Be particularly careful when transporting the Implement with the Tractor. Turn curves or go up hills only at a low speed and using a gradual steering angle. Rear mounted implements move the center of gravity to the rear and remove weight from the front wheels. Make certain, by adding front ballast, that at least 20% of the tractor's weight is on the front wheels to prevent rearing up, loss of steering control or Tractor tip-over. Slow down on rough or uneven surfaces to prevent loss of steering control which could result in property damage or possible injury. Do not transport unless 3-Point lift lever is fully raised and in the latched transport position. Dropping implement in transport can cause serious damage to the tractor and/or Implement and possibly cause the operator or others to be injured or killed.

(S3PT-02)

SAFETY

WARNING

Allow sufficient clearance for the Implement to swing outward while turning. Implements carried behind the Tractor will swing outside the tire path when making turns. Contacting a solid object while turning will cause equipment damage and possible injury. (S3PT-20)

WARNING

Make certain that the "Slow Moving Vehicle" (SMV) sign is installed in such a way as to be clearly visible and legible. When transporting the Equipment use the Tractor flashing warning lights and follow all local traffic regulations. (SG-6)

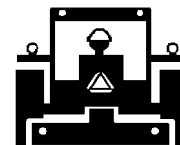

WARNING

Transport only at speeds where you can maintain control of the equipment. Serious accidents and injuries can result from operating this equipment at high speeds. Understand the Tractor and Implement and how it handles before transporting on streets and highways. Make sure the Tractor steering and brakes are in good condition and operate properly.



Before transporting the Tractor and Implement, determine the proper transport speeds for you and the equipment. Make sure you abide by the following rules:

Test the tractor at a slow speed and increase the speed slowly. Apply the Brakes smoothly to determine the stopping characteristics of the Tractor and Implement. As you increase the speed of the Tractor the stopping distance increases. Determine the maximum transport speed not to exceed 20 mph (30 kph) for transporting this equipment.

Test the equipment at a slow speed in turns. Increase the speed through the turn only after you determine that the equipment can be operated at a higher speed. Use extreme care and reduce your speed when turning sharply to prevent the tractor and implement from turning over. Determine the maximum turning speed for you and this equipment before operating on roads or uneven ground.



Only transport the Tractor and Implement at the speeds which allow you to properly control the equipment.

Be aware of the operating conditions. Do not operate the Tractor with weak or faulty brakes or worn tires. When operating down a hill or on wet or rain slick roads, the braking distance increases: use extreme care and reduce your speed. When operating in traffic always use the Tractor's flashing warning lights and reduce your speed. Be aware of traffic around you and watch out for the other guy. (SG-19)

DANGER

Be particularly careful when transporting the Implement using the tractor. Turn curves or go up or down hills only at a low speed and at a gradual steering angle. Make certain that at least 20% of the tractor's weight is on the front wheels to maintain safe steering. Slow down on rough or uneven surfaces. (STI-01)

SAFETY

WARNING

Only tow the Implement behind a properly sized and equipped Tractor which exceeds the weight of the Implement by at least 20%. DO NOT tow the Implement behind a truck or other type of vehicle. Never tow the Implement and another Implement connected in tandem. Never tow the Implement at speeds over 20 MPH. (STI-06)



WARNING

Your driving vision may be reduced or impaired by the tractor, cab, or implement. Before driving on public roadways identify any limited vision areas, and make adjustments to your operating position, mirrors, and the implement transport position so that you can clearly see the area where you will be traveling, and any traffic that may approach you. Failure to maintain adequate vision of the public roadway and traffic can result in serious injury or even death. (STI-10)

Maintenance and Service Safety Instructions and Practices

DANGER

Make sure the PTO shield, integral driveline shields, and input shields are installed when using PTO-driven equipment. Always replace any shield if it is damaged or missing. (S3PT-8)



WARNING

Relieve hydraulic pressure prior to doing any maintenance or repair work on the Implement. Place the Implement on the ground or securely blocked up, disengage the PTO, and turn off the tractor engine. Push and pull the Remote Cylinder lever in and out several times prior to starting any maintenance or repair work. (S3PT-09)



DANGER

Always disconnect the main PTO Driveline from the Tractor before performing service on the Implement. Never work on the Implement with the tractor PTO driveline connected and running. Rotating Parts, Blades or Drivelines could turn without warning and cause immediate entanglement, injury or death. (S3PT-11)

WARNING

Never interfere with factory-set hydraulic calibrations. Any change in calibration could cause a failure of the equipment and may result in injury. (SBH-13)

WARNING

Always maintain the safety signs in good readable condition. If the safety signs are missing, damaged, or unreadable, obtain and install replacement safety signs immediately. (SG-5)

WARNING

Do not modify or alter this Implement. Do not permit anyone to modify or alter this Implement, any of its components or any Implement function. (SG-8)

DANGER

Never work under the Implement, the framework, or any lifted component unless the Implement is securely supported or blocked up to prevent sudden or inadvertent falling which could cause serious injury or even death. (SG-14)



SAFETY

SAFETY

WARNING

Never attempt to lubricate, adjust, or remove material from the Implement while it is in motion or while tractor engine is running. (SG-20)

WARNING

Periodically inspect all moving parts for wear and replace when necessary with authorized service parts. Look for loose fasteners, worn or broken parts, and leaky or loose fittings. Make sure all pins have cotter pins and washers. Serious injury may occur from not maintaining this machine in good working order. (SG-21)

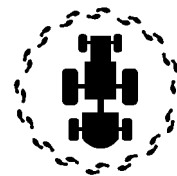

DANGER

Do Not fill fuel tank while engine is running. Refuel only after engine has cooled down. If fuel is spilled, move machine away from the area of the spill and avoid creating any source of ignition until the gasoline has evaporated. (SG-28)

WARNING

Perform service, repairs and lubrication according to the maintenance section. Ensure the unit is properly lubricated as specified in the lubrication schedule and all bolts and nuts are properly torqued. Failure to properly service, repair and maintain this Implement in good operating condition could cause component failure and possible serious injury or even death. (SG-35)

WARNING

Use caution and wear protective gloves when handling sharp objects such as blades, knives, and other cutting edges. Be alert to worn component surfaces which have sharp edges. Sharp surfaces can inflict severe laceration injuries if proper hand protection is not worn. (SG-37)

DANGER

All Safety Shields, Guards and Safety devices including (but not limited to) - the Deflectors, Chain Guards, Steel Guards, Gearbox Shields, PTO integral shields, and Retractable Door Shields should be used and maintained in good working condition. All safety devices should be inspected carefully at least daily for missing or broken components. Missing, broken, or worn items must be replaced at once to reduce the possibility of injury or death from thrown objects, entanglement, or blade contact. (SGM-3)

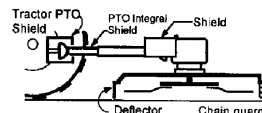

DANGER

Replace bent or broken blades with new blades. NEVER ATTEMPT TO STRAIGHTEN, WELD, OR WELD HARDFACING ON BLADES SINCE THIS WILL LIKELY CRACK OR OTHERWISE DAMAGE THE BLADE WITH SUBSEQUENT FAILURE AND POSSIBLE SERIOUS INJURY FROM THROWN BLADES. (SGM-10)

WARNING

DO NOT weld or repair rotating mower components. Welds and other repairs may cause severe vibration and/or component failure resulting in part being thrown from the mower causing serious bodily injury. See your Authorized Dealer for proper repairs. (SGM-13)

SAFETY

PARTS INFORMATION

Alamo Industrial mowers use balanced and matched system components for blade carriers, blades, cuttershafts, knives, knife hangers, rollers, drivetrain components, and bearings. These parts are made and tested to Alamo Industrial specifications. Non-genuine "will fit" parts do not consistently meet these specifications. The use of "will fit" parts may reduce mower performance, void mower warranties, and present a safety hazard. Use genuine Alamo Industrial mower parts for economy and safety. (SPRM-1)

SEE YOUR ALAMO DEALER



Be sure you have adequate knowledge of the property you will be working on. Take time to make yourself aware of any area underground lines or cables. Contact with buried lines or cable could result in **serious injury** or **death**. (STL-1)



In wet conditions where there is a likelihood of material collecting on the Implement, make certain that this material is removed before traveling on public roadways. (STL-7)

Concluding Safety Instructions and Practices

In addition to the design and configuration of this Implement, including Safety Signs and Safety Equipment, hazard control and accident prevention are dependent upon the awareness, concern, prudence, and proper training of personnel involved in the operation, transport, maintenance, and storage of the machine. Refer also to Safety Messages and operation instruction in each of the appropriate sections of the Tractor and Equipment Manuals. Pay close attention to the Safety Signs affixed to the Tractor and Equipment. (SG-18)

SAFETY

SAFETY

Decal Location

NOTE: Alamo supplies safety decals on this product to promote safe operation. Damage to the decals may occur while in shipping, use, or reconditioning. Alamo cares about the safety of its customers, operators, and bystanders, and will replace the safety decals on this product in the field, free of charge (Some shipping and handling charges may apply). Contact your Alamo dealer to order replacement decals

SAFETY

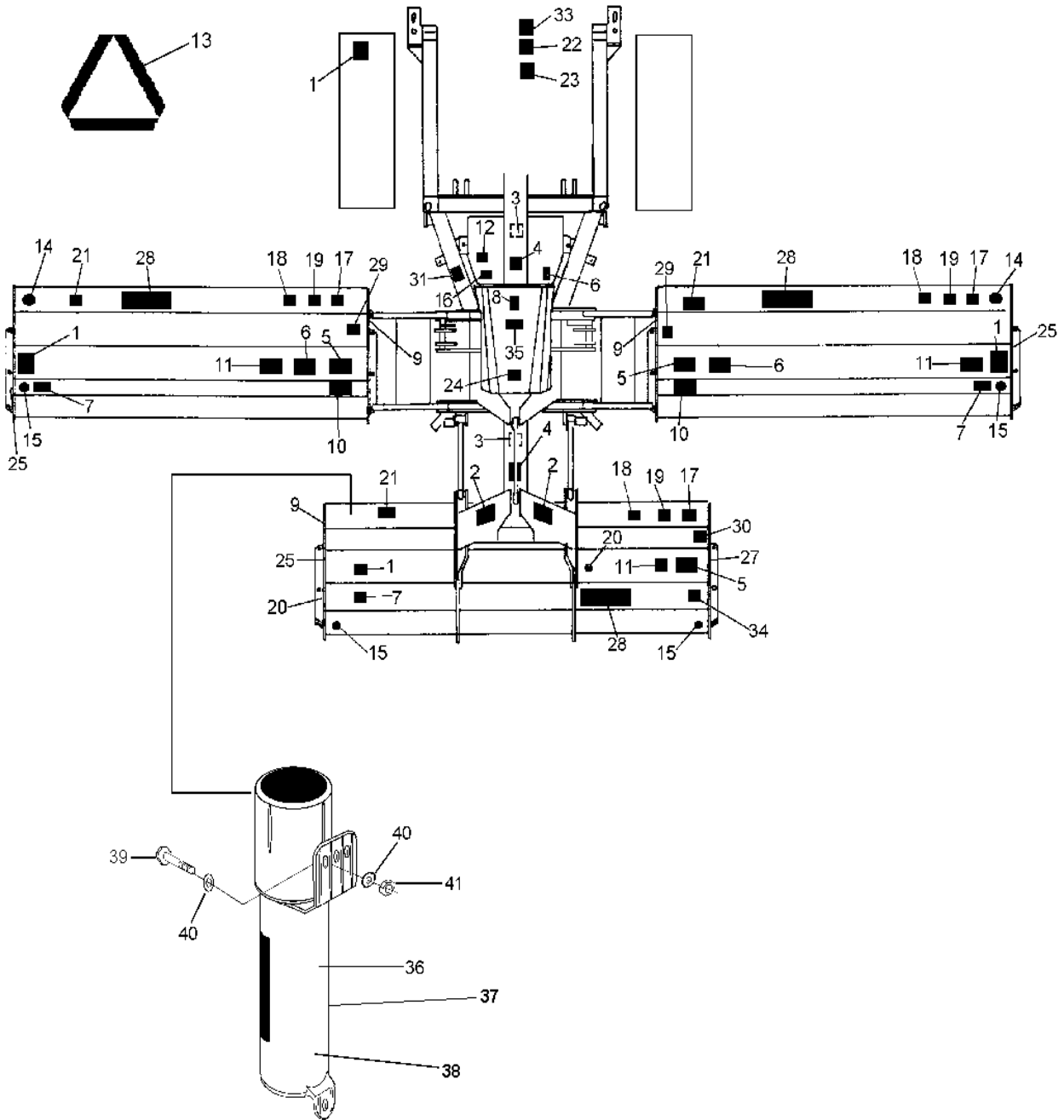

DL-FL-0016

SAFETY

SAFETY

ITEM	PART NO.	QTY	TYPE	DESCRIPTION
1.	002369	4	DANGER	Multiple-Hazard
2.	00753840	2	DANGER	Folding Wings/Wings Raised
3.	00756004	2	DANGER	D/L Shield Missing
4.	00756005	2	DANGER	Rotating D/L, Entanglement
5.	00756007	3	WARNING	Use/Repair Shields/Guards
6.	00756059	3	DANGER	Oil Penetration, Leaks
7.	00746485	3	DANGER	Cutting Blades, Thrown Objects
8.	00746494	1	DANGER	Driveline Hazards
9.	00758194	3	WARNING	Belt/Pulley Pinch Point
10.	02962765	2	DANGER	Crushing from Folding Hazard
11.	002425	3	DANGER	Removing Front Shield
12.	03200437	1	WARNING	Pressurized Tank
13.	03200347		REFLCTR	SMV Reflector
14.	99203	2	REFLCTR	Red Reflector Decal
15.	99204	4	REFLCTR	Yellow Reflector Decal
16.	03200286	1	INSTRUCT	Hyd Oil and Type
17.	03200432	3	INSTRUCT	Genuine ALAMO Flail Parts
18.	002023	3	INSTRUCT	Cutting Height Adjustment
19.	000108	3	INSTRUCT	Flail Operation
20.	000678	2	INSTRUCT	Grease Fitting Inside
21.	002490	3	INSTRUCT	Wing Unit Lube Chart
22.	02962748	2	INSTRUCT	On/Off Solenoid Switch
23.	02965093	1	INSTRUCT	Do Not Overspeed Engine
24.	00763977	1	INSTRUCT	Notice to Owner
25.	001650	1	LOGO	ALAMO (7.5 x 7)
26.	001651	4	LOGO	ALAMO IND
27.	02960766	3	LOGO	ALAMO (4 x 5)
28.	002489	3	NAME	VERSA PRO (Name)
29.	nfs (L)	1	SER PLT	Left Wing Serial Plate'
30.	nfs (R)	1	SER PLT	Right Wing Serial Plate
31.	nfs (C)	1	SER PLT	Center Mower Serial Plate
32.	nfs (F)	1	SER PLT	VERSA PRO Serial Plate
33.	002505	1	INSTRUCT	Wing Lowering
34.	001830	1	INSTRUCT	Lubrication Rear
35.	00773723	2	DANGER	Peligro, Driveline
36.	02977417	1	INSTRUCT	Operators Manual Inside
37.	00776031	1	_____	Canister, Operations Manual
38.	803350C	1	_____	Operator's Manual, Versa Pro
39.	10058000	3	_____	Bolt
40.	00024100	6	_____	Flatwasher
41.	02959924	3	_____	Locknut

SAFETY

Decal Description

Peligro Translation, If you do not know how to read English, please find someone who knows how to read English.



P/N 00725746

DANGER! Stay clear when lowering or raising wings.

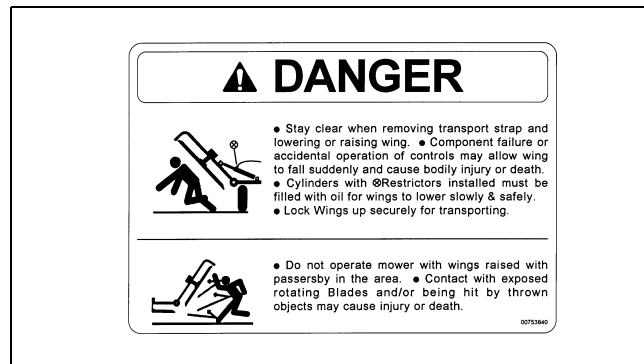

P/N 00753840

DANGER! Guard Missing, Do Not Operate. If you see this decal, Do Not Operate the mower until the shield has been replaced.



P/N 00756004

DANGER! Rotating Driveline Keep Away, Contact can cause death.



P/N 00756005

SAFETY

WARNING! Keep all safety shielding installed, repaired and replaced when damaged so that machine stays in safe condition.

P/N 00756007

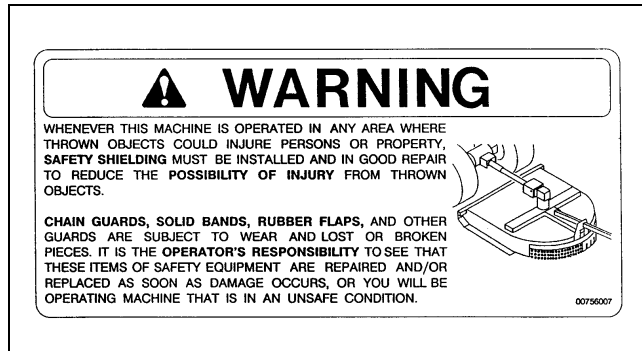

WARNING! Never use your hand to check for oil leaks. Always use paper or cardboard.

P/N 00756059



DANGER! Keep Away - Rotating Blades

P/N 00756485

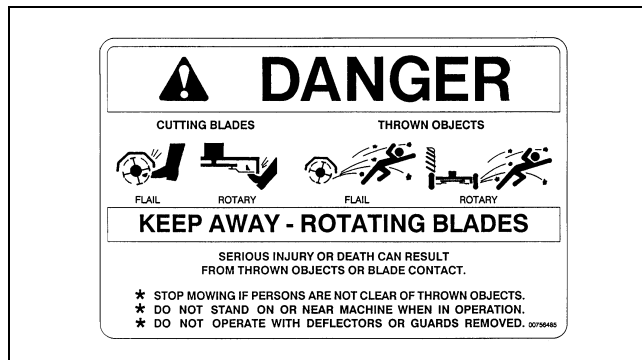

DANGER! Make certain that drivelines are correct length and are securely attached.

P/N 00756494



SAFETY

SAFETY

WARNING! Do not operate with Belt Shield removed. Finger(s) may be pinched off if get caught between V-Belt and Pulley.



P/N 00758194

DANGER! Crushing and Pinch Points. Moving machinery parts can pinch or crush or fall-which may cause injury or death.



P/N 02962765

DANGER! Keep Away! If front deflector shield is removed from flail housing, serious injury to or amputation of hands, feet, or limbs may occur from blades contact. Always make sure that all shields are in place at all times.



P/N 002425

WARNING: Pressurized Tank

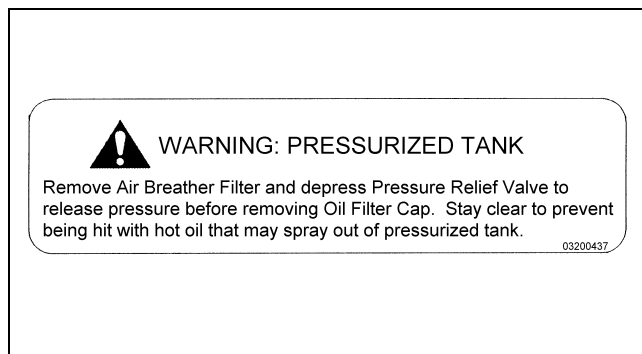

03200437

SAFETY

Slow Moving Vehicle Decal. Keep SMV reflector clean and visible. DO NOT transport or operate without the SMV.

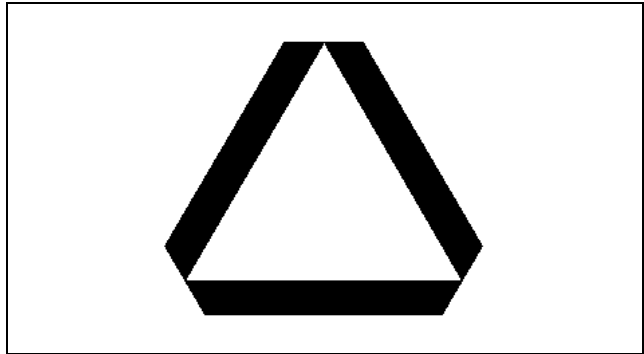

P/N 03200347

Red Reflector Tape.

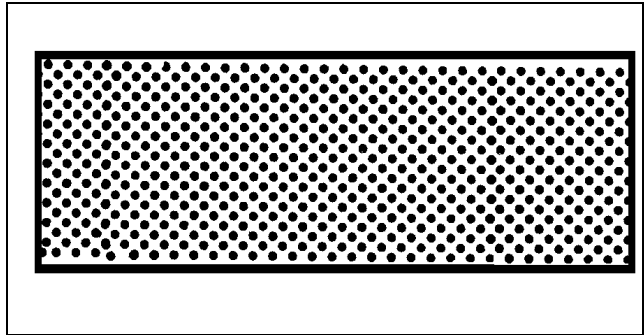

P/N 99203

Yellow Reflector Tape.

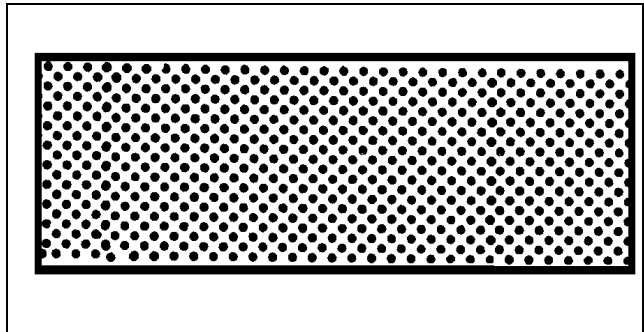

P/N 99204

INSTRUCTIONS - Use only DEXTRON TYPE A Automatic Transmission Fluid. Maintain ATF Level within the height of the sight glass.

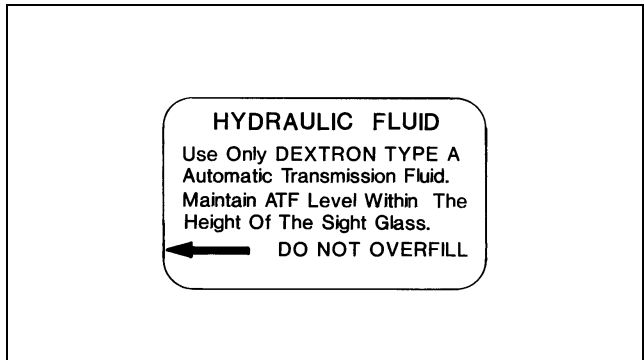

P/N 03200286

SAFETY

SAFETY

SAFETY

IMPORTANT - Use ALAMO Genuine Flail Parts.

IMPORTANT

ALAMO GENUINE FLAIL PARTS

ALAMO INDUSTRIAL Flail Mowers use dynamically balanced and matched system components for Cutter Shafts, Knives, Knife Hangers, Rollers, Drivetrain components, Bearings, Belts, and Pulleys. ALAMO INDUSTRIAL parts are made and tested to meet close-tolerance specifications of balance, quality, and consistency that assure long, trouble-free service. The use of inferior "will fit" parts will void warranty for your ALAMO INDUSTRIAL implement and may cause premature or catastrophic failure which can result in serious injury or death. If you have any questions concerning the repair parts you are using, contact ALAMO INDUSTRIAL 1502 E. Walnut Seguin, TX 78155 (830) 372-3551.

ALAMO
INDUSTRIAL

03000432

P/N 03200432

Cutting Height Adjustment Chart

MOWER CUTTING HEIGHT ADJUSTMENT

DESIRED CUTTING HEIGHT (INCHES)	ADJUSTMENT BRACKET HOLE	MOWER END PLATE HOLE
1/2	B	2
1	A	1
1-1/2	B	3
2	A	2
2-1/2	B	4
3	A	3
3-1/2	B	5
4	A	4
4-1/2	B	6
5	A	5
5-1/2	B	7
6	A	6

P/N 002023

Instructions to properly lubricate and check mower for potential problems prior to operation.

OPERATING INSTRUCTIONS

This Mower will give long satisfactory service with a minimum of upkeep cost if the following procedure is followed:

1. **KEEP PROPERLY LUBRICATED**
 - a. **BEARINGS** - Use a lithium-based #2 Bearing Grease such as Shell Alvania #2, Sinclair Litholene, Mobil BRB, Texaco Marfak #2, Standard Stanolith #57, etc.
 - b. **GEARBOX** - Use SAE EP90 oil.
2. **KEEP FASTENERS TIGHTENED**
 - a. Normally, if Fasteners loosen after being properly tightened, the Mower is vibrating more than is acceptable and permanent damage can occur rapidly.
 - b. See Bolt Chart for proper tightening torque.
3. **KEEP THE MOWER RUNNING SMOOTHLY AND QUIETLY.**
 - a. After hitting any obstruction and at the first sign of any unusual vibration or noise, STOP THE MOWER, and do not operate again until the problem is found and corrected. VIBRATION CAN DESTROY THE ENTIRE MOWER IN A SHORT TIME.
 - b. Inspect for broken or missing Knives, Knives restricted from swinging freely, worn Bearings, a bent Shaft, or other conditions causing out-of-balance rotation.
 - c. See Operators Manual for details on causes and correction of vibration of Flail Mowers.

NOTICE: Warranty does not cover damage resulting from the failure to observe these reasonable procedures. 000108

P/N 000108

Information that Grease Fitting is present and must apply grease.

GREASE
FITTING
INSIDE

P/N 000678

SAFETY

8 Hour Lubrication Chart

P/N 002490

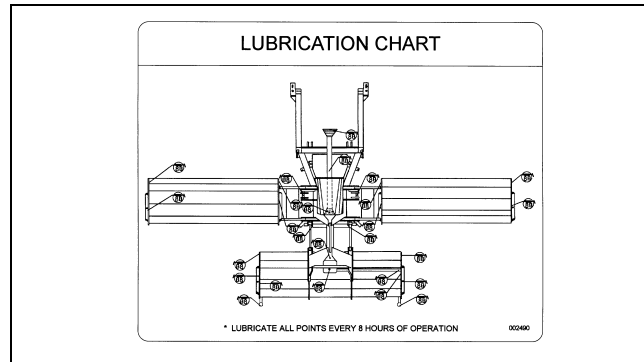

INFORMATION - Pull to Start, Push to Stop

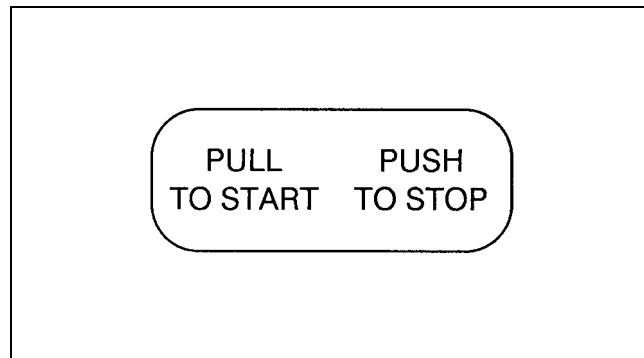

02962748

INFORMATION - To prevent premature hydraulic component failure, do not over speed the engine. When using the mower attachment, operate tractor at the engine speed which will deliver 540 PTO RPM on Tachometer. Over speeding the engine and pump when operating the mower will overheat and rapidly ruin the oil which will decrease the life of the hydraulic components.

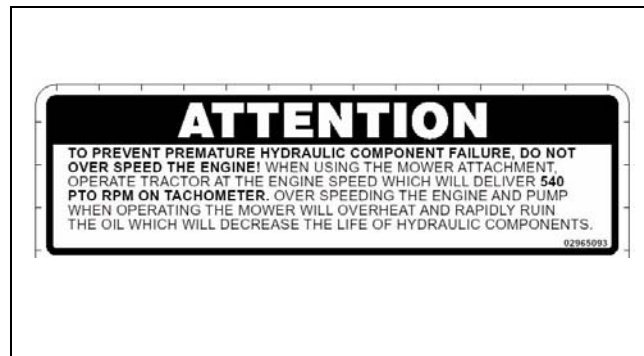

P/N 02965093

Operator's Manual (with repair parts) and warranty was attached to this implement during final inspection.

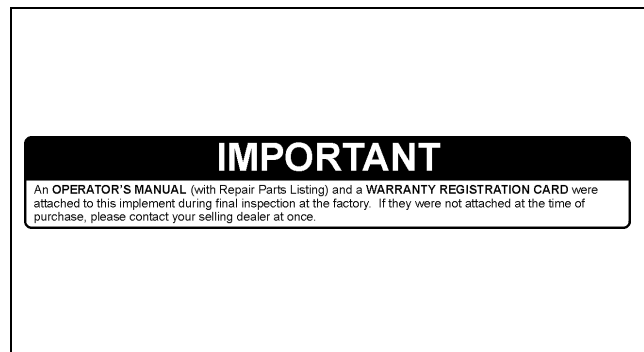

P/N 00763977

SAFETY

SAFETY

SAFETY

ALAMO NAME LOGO.



P/N 001650

ALAMO INDUSTRIAL LOGO



P/N 001651

NAME LOGO - Alamo Industrial



P/N 02960766

NAME - VERSA PRO

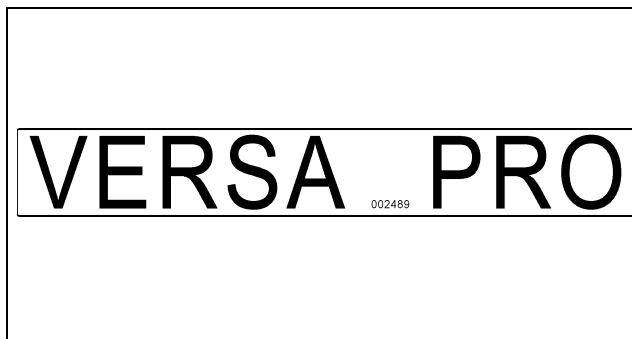

P/N 002489

SAFETY

Wing Lowering Instructions. Following instructions will assure the safety of the operator and unit.

P/N 002505

WING LOWERING INSTRUCTIONS

1. Be sure forward/reverse lever is locked in neutral position before attempting to lower wings from locked position.
2. It is necessary to fully raise wings before releasing latches.
3. Pull red knobs. Slowly lower wings by pushing control levers forward.
4. Wings will automatically lock when raised to vertical position.

PN002505

INFORMATION - 8 Hour Lubrication Chart

P/N 001830

LUBRICATION CHART

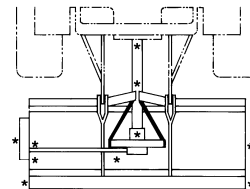

* LUBRICATE ALL POINTS EVERY 8 HOURS OF OPERATION
001830

PELIGRO! Spanish Translation for Driveline Safety

P/N 00773723



INSTRUCTIONS - Read Operator's Manual and Understand, before operating Tractor and Implement.

P/N 02977417

OPERATOR'S MANUAL INSIDE

READ & UNDERSTAND
Before Operating Tractor & Implement



If Manual is missing, obtain one before operating from Dealer or ALAMO INDUSTRIAL, 1502 E. Walnut, Seguin, TX 78155. Customer Service 800-356-6286

ALAMO
INDUSTRIAL

02977417

SAFETY

SAFETY

Read Operator's Manual! The operator's manual is located inside this canister. If the manual is missing order one from your dealer.

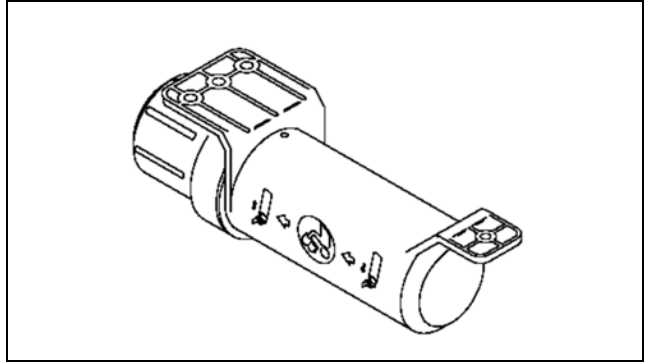

P/N 00776031

SAFETY

SAFETY

Federal Laws and Regulations

This section is intended to explain in broad terms the concept and effect of federal laws and regulations concerning employer and employee equipment operators. This section is not intended as a legal interpretation of the law and should not be considered as such.

Employer-Employee Operator Regulations

U.S. Public Law 91-596 (The Williams-Steiger Occupational and Health Act of 1970) OSHA

This Act Seeks:

“...to assure so far as possible every working man and woman in the nation safe and healthful working conditions and to preserve our human resources...”

DUTIES

Sec. 5 (a) Each employer-

- (1) shall furnish to each of his employees employment and a place of employment which are free from recognized hazards that are causing or are likely to cause death or serious physical harm to his employees;
- (2) shall comply with occupational safety and health standards promulgated under this Act.
- (b) Each employee shall comply with occupational safety and health standards and all rules, regulations and orders issued pursuant to this Act which are applicable to his own actions and conduct.

OSHA Regulations

OSHA regulations state in part: “At the time of initial assignment and at least annually thereafter, the employer shall instruct every employee in the safe operation and servicing of all equipment with which the employee is, or will be involved.”

Employer Responsibilities:

To ensure employee safety during Tractor and Implement operation, it is the employer’s responsibility to:

1. Train the employee in the proper and safe operation of the Tractor and Implement.
2. Require that the employee read and fully understand the Tractor and Implement Operator’s manual.
3. Permit only qualified and properly trained employees to operate the Tractor and Implement.
4. Maintain the Tractor and Implement in a safe operational condition and maintain all shields and guards on the equipment.
5. Ensure the Tractor is equipped with a functional ROPS and seat belt and require that the employee operator securely fasten the safety belt and operate with the ROPS in the raised position at all times.
6. Forbid the employee operator to carry additional riders on the Tractor or Implement.
7. Provide the required tools to maintain the Tractor and Implement in a good safe working condition and provide the necessary support devices to secure the equipment safely while performing repairs and service.
8. Require that the employee operator stop operation if bystanders or passersby come within 25 feet.

Child Labor Under 16 Years of Age

Some regulations specify that no one under the age of 16 may operate power machinery. It is your responsibility to know what these regulations are in your own area or situation. (Refer to U.S. Dept. of Labor, Employment Standard Administration, Wage & Home Division, Child Labor Bulletin #102.)



Safety Manual

*For Operators
and Mechanics*

Industrial/ Agricultural Mower

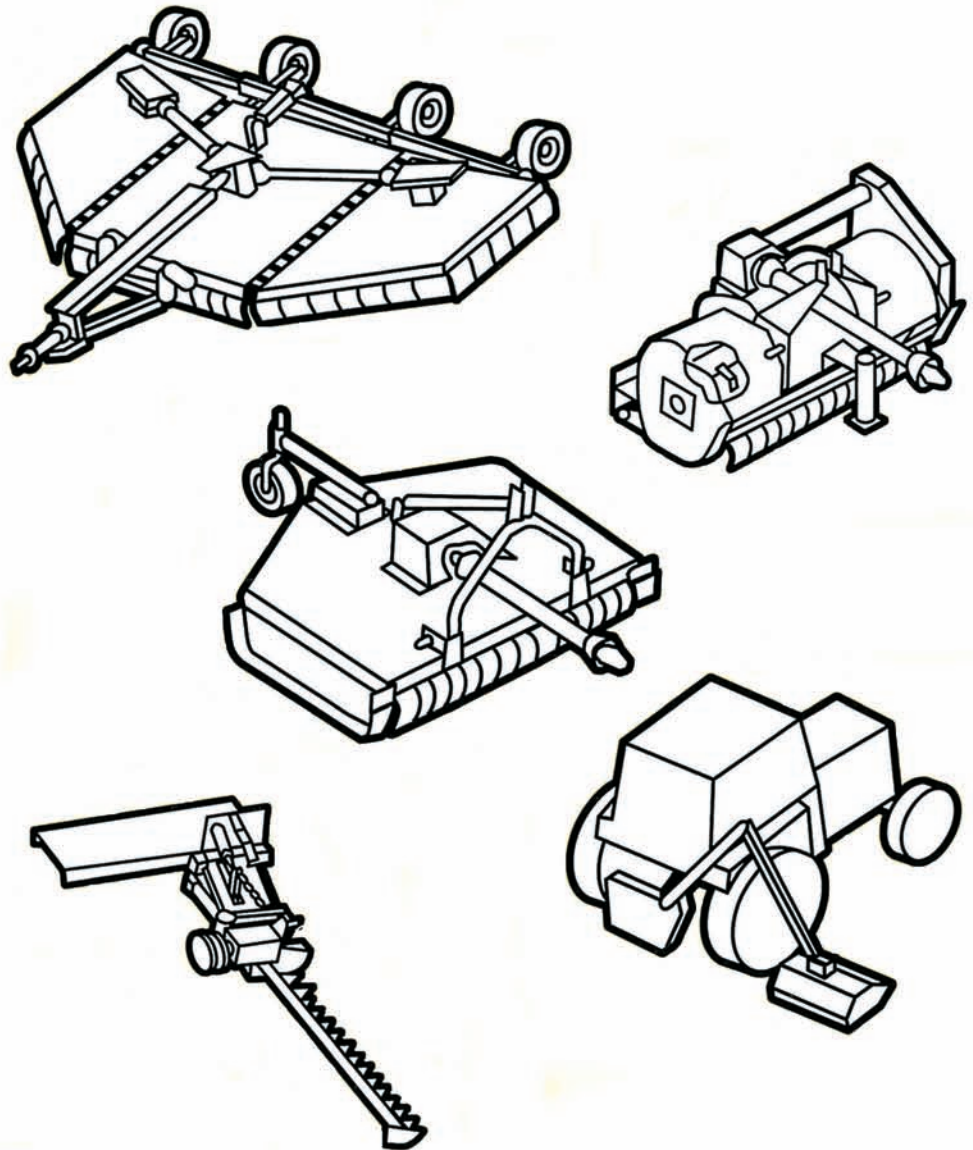

111 E. Wisconsin Avenue • Milwaukee, Wisconsin 53202 U.S.A.
www.aem.org

Contents

Acknowledgement	2
Forward	3
A Word to the User	3
Safety Alert Symbol	4
Industrial/Agricultural Mower Types	4
Be a Responsible Operator	5
Safety Management of Hazards and Risks	6
Follow a Safety Program	11
Safety-Before Operation	11
Safety-Starting and Testing	13
Safety-During Operation	14
Safety-During Shutdown	18
Safety-During Maintenance	19
One Final Word	21

Acknowledgement

We wish to acknowledge the contributions of the members of the Association of Equipment Manufacturers to the preparation of this Safety Manual.

Copyright
© 2000 AEM (formerly Equipment Manufacturers Institute). Revised 08.2003. All rights reserved.

Forward

This Safety Manual is intended to point out some of the basic safety situations which may be encountered during the normal operation and maintenance of your machine and to suggest possible ways of dealing with these conditions. This manual is NOT a substitute for the manufacturer's manual(s).

Additional precautions may be necessary, or some instructions may not be applicable, depending on the equipment, attachment devices, and conditions at the worksite or in the service area. The manufacturer has no direct control over machine application, operation, inspection, lubrication, or maintenance. Therefore, it is **YOUR** responsibility to use good safety practices in these areas.

The information provided in this manual supplements the specific information about your machine that is contained in the manufacturer's manual(s). Other information which may affect the safe operation of your machine may be contained on safety signs or in insurance requirements, employer's safety and training programs, safety codes, local, state/provincial and national laws, rules and regulations.

IMPORTANT: *If you do not have the manufacturer's manual(s) for your particular machine, get a replacement manual from your employer, equipment dealer, or the manufacturer of your machine. Keep this safety manual and the manufacturer's manual(s) with your machine.*

A Word to the User

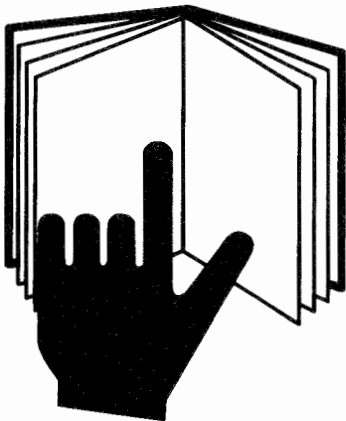

It is your responsibility to read and understand this safety manual and the manufacturer's manual(s) before operating this machine. This safety manual takes you step-by-step through your working day. The safety manual, manufacturer's manual(s), safety signs (decals) and safety precautions must be explained to those users or operators who cannot read the material.

In addition to equipment design and configuration, **HAZARD CONTROL** and **ACCIDENT PREVENTION** are dependent upon the owner's and operator's awareness, concern, prudence, and proper training in the operation, transport, maintenance and storage of equipment.

Remember that **YOU** are the key to safety. Good safety practices not only protect you but also protect the people around you. Study this manual and the manufacturer's manual(s) for your specific machine. Make them a working part of your safety program. Keep in mind that this safety manual is written only for industrial and agricultural mowers.

Practice all usual and customary safe working precautions and above all – remember safety is up to YOU. Only YOU can prevent serious injury or death from unsafe practices.

Safety Alerts

Symbol

This Safety Alert Symbol means:

**“ATTENTION! BECOME ALERT!
YOUR SAFETY IS INVOLVED!”**

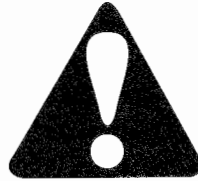

The Safety Alert Symbol identifies important safety messages on equipment, safety signs, in manuals or elsewhere. When you see this symbol, be alert to the possibility of death or personal injury. Follow the instructions in the safety message.

Signal Words

Signal words are distinctive words that will typically be found on safety decals on this equipment or other equipment on the worksite. These words are intended to alert the viewer to the existence and relative degree of a hazard.



This signal word indicates an imminently hazardous situation which, not avoided, will result in death or serious injury.



This signal word indicates a potentially hazardous situation which, if not avoided, could result in death or serious injury.



This signal word indicates a potentially hazardous situation exists which, if not avoided, may result in minor or moderate injury.

- ACCIDENTS DISABLE AND KILL.
- ACCIDENTS COST.
- ACCIDENTS CAN BE AVOIDED.

Industrial/Agricultural Mowers

A mower for pasture clipping, crop residue shredding, heavy brush cutting for land clearing, waterways, right-of-ways, road side or highway mowing.

INDUSTRIAL/AGRICULTURAL MOWER TYPES:

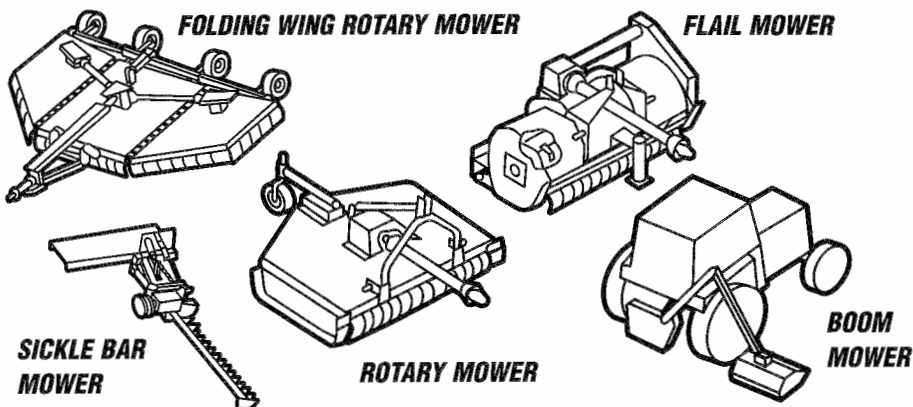

Be a Responsible Operator



DON'T
Drink & Drive



DON'T
Take
Drugs & Drive

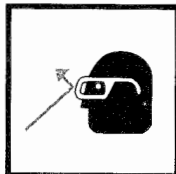
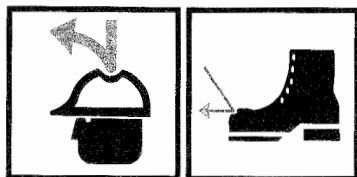

PROTECT
Yourself



CALL
For Assistance

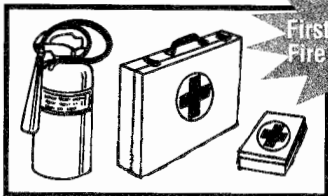

LOCATE
First Aid Kits and
Fire Extinguisher

For safe operation of your equipment, you must be a responsible operator. A responsible operator must clearly understand the written instructions supplied by the manufacturer, be trained—including actual operation of the equipment and know the safety rules and regulations for the worksite.

Drugs and alcohol will affect an operator's alertness and coordination and therefore affect the operator's ability to operate the equipment safely. An operator should **NEVER** use drugs which affect alertness, judgement and coordination or alcohol while operating motorized equipment, including tractors and mowers. An operator on prescription or over-the-counter medication must consult a medical professional regarding any side effects of the medication that would hinder his or her ability to operate this equipment safely. **NEVER** knowingly allow anyone to operate this equipment when their alertness, judgement or coordination is impaired.

Protect Yourself

Wear all the protective clothing and personal safety devices issued to you or called for by job conditions.

You may need:

- Hard hat
- Safety shoes
- Safety glasses with side shields, goggles or face shield
- Heavy gloves
- Hearing protection
- Reflective clothing
- Wet weather gear
- Respirator or filter mask

Wear adequate clothing for the job conditions.

Always know where to get assistance in the case of an emergency. Know where to find and how to use a first aid kit and fire extinguisher/fire suppression system.

**Stay alert. Avoid accidents.
Don't learn safety the hard way.**

Safety Management of Hazards and Risks

In addition to equipment design and configuration, **HAZARD CONTROL** and **ACCIDENT PREVENTION** are dependent upon the owner's and operator's awareness, concern, prudence, and proper training in the operation, transport, maintenance and storage of equipment.

SAFETY MANAGEMENT OF HAZARDS AND RISKS IS ESSENTIAL TO RESPONSIBLE OWNERS AND OPERATORS OF TRACTORS AND MOWERS.

REVIEW THE FOLLOWING SAFETY MANAGEMENT OF LISTED HAZARDS AND RISKS:

Thrown Object Hazard

POSSIBLE THROWN OBJECT INJURY RISKS EXIST FOR MOWER OPERATORS AND BYSTANDERS DURING MOWER OPERATIONS FROM THE FOLLOWING:

DISCHARGED OBJECTS (ROCKS, DEBRIS, BROKEN MOWER BLADES, BLADE BOLTS, CABLES, CHAINS, WIRE, ETC....) FROM THE MOWER.

Equipment Protective Devices And Recommended Safety Practices

The mower deck and protective devices cannot prevent all objects or debris from escaping the blade enclosure area in every mowing condition. It is possible for objects to escape and travel several hundred (300) feet.

RECOMMENDED SAFETY PRACTICES

Read manufacturer's operator manual(s) for recommended operating safety practices. Explain the practices to users or operators who cannot read.

TO HELP PREVENT SERIOUS INJURY OR DEATH FROM OBJECTS STRIKING OPERATOR OR OTHER PERSONS DO THE FOLLOWING:

BYSTANDERS SAFETY

- Keep bystanders several hundred (300) feet from mowing area.

EQUIPMENT PROTECTIVE DEVICES SAFETY

To contain, deflect or reduce thrown objects from blade enclosure area:

- Keep chain, flexible or solid deflector shields in place on the front and rear of the mower deck and in good repair.
- Do not operate with damaged or missing thrown object shielding.

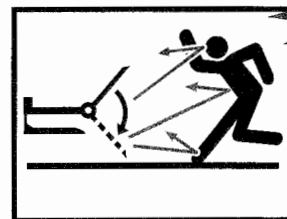
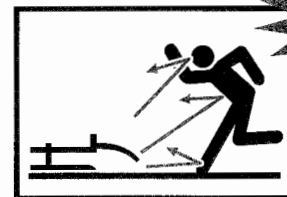
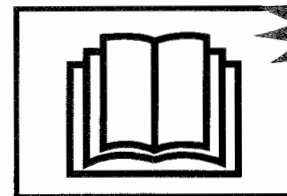
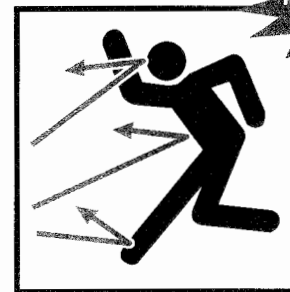
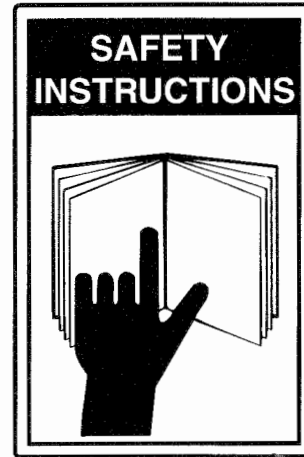

THROWN Object Hazard

READ Manuals

KEEP Bystanders Away

THROWN Object Hazard

**USE ROPS
Enclosed Cabs
or Protective
Enclosures**

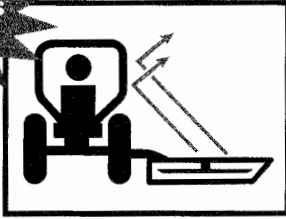

**USE Proper
PTO Speed**

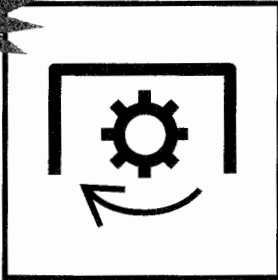

**MAINTAIN
Equipment**



OPERATOR SAFETY

Raised wings, side mount and boom type mower operations may reduce the mower's thrown object shielding effectiveness for the mower operator's protection.

Do the following to increase operator protection from thrown objects during these mowing operations:

- Use enclosed ROPS cabs, special protective enclosures, screens or other operator shielding devices when performing these operations.

EXCEEDING RECOMMENDED PTO SPEEDS

Do not exceed manufacturer's recommended PTO speeds.

Excessive PTO speeds may cause:

- Blade failures
- Higher velocity objects escaping or broken blades being thrown from mower blade enclosures.
- Potential 540 rpm driveline failures operating at 750 to 1000 rpm speeds.

OTHER SAFETY PRACTICES:

- Never operate mower with broken, bent, missing, or severely worn blades.
- Before mowing, remove debris and foreign objects to avoid them being picked up and thrown out by the mower.
- * Do not operate the mower in transport or in raised wing positions.

RECOMMENDED MAINTENANCE PRACTICES

Read manufacturer's operator manual(s) inspection and maintenance instructions for chain guards, flexible or solid deflector shielding:

- Replace worn or damaged guards and other shielding before mowing.
- Use only manufacturer's replacement guards and shielding. Other guarding or shielding sources may not fit or have inadequate materials to meet the strength requirements of the equipment.
- Replace worn or damaged decals and warning instructions.
- Explain the inspection and maintenance instructions to those users or operators who cannot read.

Rotating Blades and Driveline Hazards and Risks

A POSSIBLE INJURY RISK EXISTS TO MOWER OPERATORS AND BYSTANDERS DURING MOWING OPERATIONS FROM THE FOLLOWING:

- BODY CONTACT WITH ROTATING BLADES.
- BODY ENTANGLEMENT WITH ROTATING DRIVELINES AND PARTS.

Equipment Protective Devices and Recommended Safety Practices

RECOMMENDED SAFETY PRACTICES

Read manufacturer's operator manual(s) for recommended operating safety practices. Explain the practices to those users or operators who cannot read. To help prevent serious injury or death from moving blade contact, driveline or parts entanglement of operators or other persons do the following:

BYSTANDERS SAFETY

- Do not operate near bystanders.
- Keep other persons several hundred (300) feet from the mowing area.

OPERATOR SAFETY PRACTICES

- Do not allow riders on tractor or mower. Securely fasten seat belt when mowing.
- Use proper equipment shutdown practice before servicing, adjusting, cleaning or unclogging the mower.
- Keep clear of rotating blades, parts, and drivelines.
- Never start tractor engine while standing beside equipment.
- Only start tractor engine while sitting in operator's seat with seat belt fastened.

RECOMMENDED GUARDS, DRIVELINE GUARDS AND SHIELDING SAFETY PRACTICES

- Keep guards, driveline and other shielding in place and in good repair.
- Do not operate mower with missing or damaged guards, driveline guards or other shielding.

RECOMMENDED MAINTENANCE PRACTICES

Read manufacturer's operator manual(s) inspection and maintenance instructions for guards, driveline guards and other shielding:

- Replace worn or damaged guards, driveline guards and other shielding before mowing.
- Use only manufacturer's replacement guards and shielding. Other guarding or shielding sources may not fit or have inadequate materials to meet the strength requirements of the equipment.
- Replace worn or damaged decals and warning instructions.
- Explain the inspection and maintenance instructions to those users or operators who cannot read.

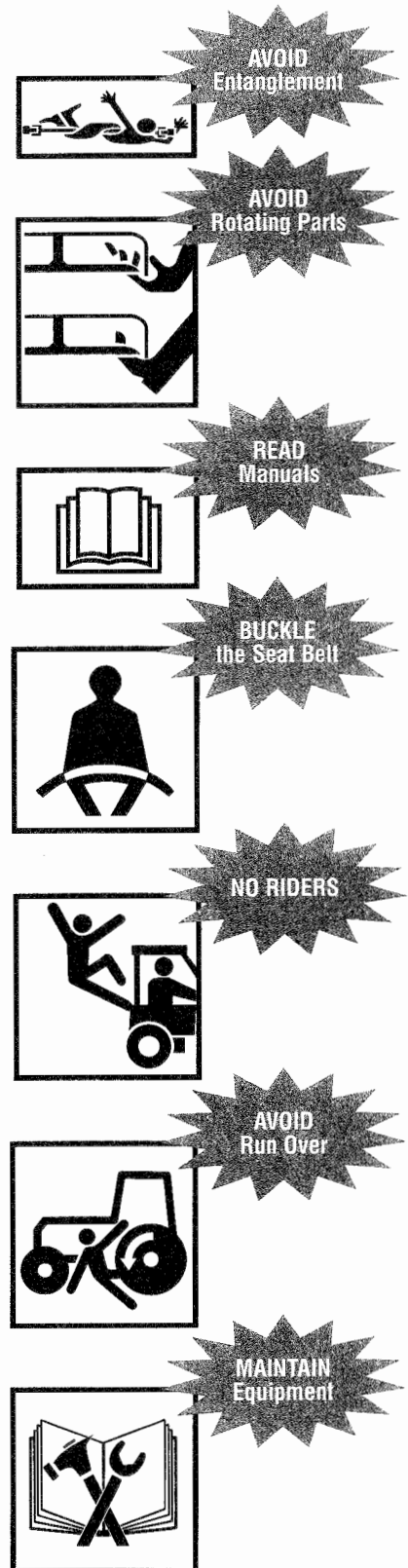

Tractor and Mower Rollover or Overturn Hazards and Risks

A POSSIBLE ROLLOVER OR OVERTURN INJURY RISK EXISTS TO MOWER OPERATORS DURING MOWING OPERATIONS FROM THE FOLLOWING:

- ROUGH TERRAIN, STEEP SLOPES, HOLES, BUMPS, RUTS, ROCKS, STUMPS OR OTHER OBSTRUCTIONS THAT COULD OVERTURN TRACTOR AND MOWER.
- EXCESSIVE GROUND SPEEDS FOR THESE TERRAIN CONDITIONS.

Equipment Protective Devices and Recommended Safety Practices

When possible remove stumps, stones, etc.. or mark them and other obstructions clearly to avoid upsets, breakdowns, and dangerous driving conditions. Use extreme care to maintain control over the equipment when operating in these terrain conditions.

RECOMMENDED-TRACTOR ROPS

A tractor equipped with ROPS or enclosed ROPS cab and seat belt for operator safety is essential for additional operator protection when operating mower in these terrain conditions.

RECOMMENDED-TRACTOR STABILITY ADJUSTMENTS

Read the tractor operator's manual for adjustments to increase tractor stability:

- Adding front and rear wheel weights or ballast.
- Adjusting wheel spacing to maximum width .
- Adding off-side counter ballast to side-mounted and boom mowers.
- Explain adjustments to those users or operators who cannot read.

RECOMMENDED SAFETY PRACTICES

Read manufacturer's operator manual(s) for recommended operating safety practices. Explain the practices to those users or operators who cannot read. **To help prevent serious injury or death to the operator from tractor and mower overturns, do the following:**

- Securely fasten seat belt when mowing with ROPS equipped tractors.
- Avoid excessive ground speed for terrain conditions.
- Avoid sudden starts, stops and turns when operating up, down or across slopes.
- Avoid slippery ground conditions.
- Make wide and gradual turns.
- Plan to mow down hill on steep slopes to avoid overturning.

Falling Mower or Parts Crushing Hazards and Risks

A POSSIBLE CRUSHING INJURY RISK EXISTS FOR MOWER OPERATORS AND OTHERS DURING MOWING OPERATIONS FROM THE FOLLOWING:

- FALLING MOWER OR EQUIPMENT FROM HYDRAULIC SYSTEM FAILURE.
- FAILURE TO SECURELY SUPPORT, BLOCK-UP OR LOCK-UP LIFTED MOWER OR EQUIPMENT PARTS.

**AVOID
Rollover**

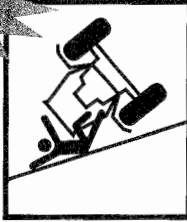

**USE
Tractor ROPS**



**READ
Manuals**



**ADD
Ballast**



**WIDEN
Wheel Spacing
and ADD Off-Side
Ballast**



**BUCKLE
the Seat Belt**



**AVOID
CRUSHING
Lock-Up Wing**



Equipment Protective Devices and Recommended Safety Practices

Read manufacturer's operator manual(s) for recommended operating safety practices. Explain the practices to those users or operators who cannot read. **To help prevent serious injury or death to operators and other from alling mower or equipment parts, do the following:**

RECOMMENDED SAFETY PRACTICES

Before working near or underneath lifted mower or equipment parts:

- Use proper equipment shutdown practices before servicing, adjusting, cleaning or unclogging the mower.
- Securely support or block-up raised mower or equipment parts.
- Securely support, block-up or lock-up wings with locking devices on wing type mowers or lower mower or equipment parts to the ground.
- Use transport locks when transporting mower on public roads.

High Pressure Hydraulic Fluid Leak Hazards and Risks

A POSSIBLE HIGH PRESSURE FLUID SKIN INJECTION INJURY AND GANGRENE RISK EXISTS FOR MOWER OPERATORS AND OTHERS FROM HIGH PRESSURE HYDRAULIC OR DIESEL OIL LEAK INJECTION INTO THE SKIN.

TO AVOID GANGRENE, INJECTED FLUID MUST BE SURGICALLY REMOVED WITHIN A FEW HOURS BY A DOCTOR FAMILIAR WITH THIS TYPE OF INJURY.

RECOMMENDED SAFETY PRACTICES

Read manufacturer's operator manual(s) for recommended operating safety practices. Explain the practices to those users or operators who cannot read. High pressure fluid pinhole leaks can be almost invisible.

To help prevent serious injury or death, do the following:

- Search for leaks with cardboard or wood.
- Do not use hands to check for leaks.
- Relieve system pressure before disconnecting lines.
- Before applying system pressure:
 - Check for damaged lines, pipes, and hoses.
 - Check to insure tight connections.
- Before operating pressurized systems:
 - Purge air from system.
 - Refer to the manufacturer's operator manual(s) for instructions.
 - Explain the procedures to those users or operators who cannot read.

Tractor Refueling Hazards and Risks

To avoid serious injury or death from fire during refueling:

- Shut off engine and ignition.
- Never fill fuel tank near open flames.
- Never smoke while refueling.
- Avoid static electricity sparks by grounding fuel nozzle against tank filler neck.
- Avoid overfilling tank or spilling fuel.
- Clean up any spilled fuel immediately.
- Always replace fuel cap.

To avoid serious injury or death from engine exhaust fumes:

- Adequately ventilate enclosed spaces before starting the engine.

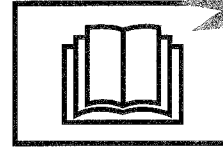

**READ
Manuals**

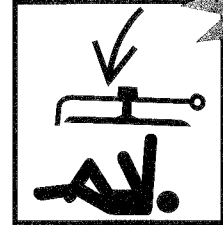

**AVOID
CRUSHING
Block-Up or
Securely Support
Mower**



**HIGH
PRESSURE FLUID
Can Inject
into the Body**

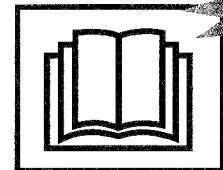

**READ
Manuals**

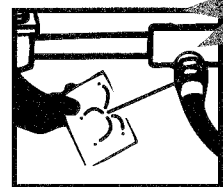

**AVOID
INJECTION
Use Cardboard
Not Hands**



**AVOID
Fires and
Explosions**

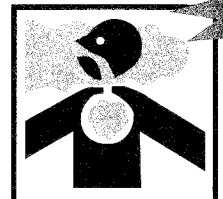

**AVOID
Exhaust Fumes**

Follow A Safety Program

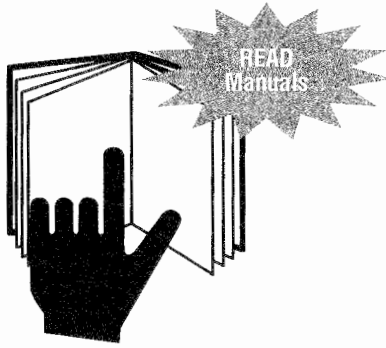

SAFETY IS IMPORTANT TO RESPONSIBLE OWNERS AND OPERATORS OF TRACTORS AND MOWERS. DO THE FOLLOWING FOR YOUR SAFE MOWING OPERATION:

BE A QUALIFIED OPERATOR BY:

- Reading, understanding and obeying the manufacturer's written instructions in operator manual(s) and safety signs on mower and tractor.
- Receiving operational training with mower and tractor.
- Asking your equipment dealer or supervisor to explain things you do not understand.
- Explaining the written instructions in the operator manual(s) and safety signs (decals) on the mower and tractor to those users or operators who cannot read.

Safety Before Operation

Know Job Site Safety Rules And Regulations

Ask your supervisor about equipment operation safety rules you will be expected to obey.

Some basic rules for your's and others' safety:

- A ROPS and seat belt equipped tractor is required for operator protection during mowing operations.
- Know mower and tractor operating capacity and characteristics.
- Never alter or remove safety equipment.
- Never allow children or unqualified persons to operate mower or tractor.
- Never allow riders on mower or tractor.
- Keep others away from mowing operation.
- Use proper equipment shutdown practice before dismounting tractor.
- Allow all moving parts to stop before making equipment inspections, repairs, or adjustments.
- Securely support or block-up mower before working beneath mower or lifted components.
- Wear personal protective clothing and safety devices issued to you or recommended by the equipment manufacturer.



Know Tractor And Mower Controls

Know the following about your tractor and mower:

- Function, purpose and use of controls.
- Safe operating speeds.
- Safe slope and uneven terrain capabilities.
- Braking and steering characteristics.
- Tractor and mower operating clearances.
- How to stop equipment quickly in an emergency.

Use All Available Equipment Safety Devices

To help keep you and others around you safe:

- Make certain manufacturer's recommended guards, shields and safety signs are installed on equipment and in good condition.
- Keep all protective devices in place and securely fastened.
- **NEVER** operate your equipment with missing, disconnected or damaged safety devices.
- Use ballast and weight required for equipment operational stability.

Check The Mower And Tractor Equipment

Before beginning your work day:

- Check for loose, broken, missing or damaged tractor and mower parts.
- Repair or replace these parts when needed.
- Check for proper tractor and mower attachments.
- Check for proper tractor and mower PTO rpm rating match.
- Check mower blades condition. Sharpen or replace per manufacturer's recommendation. Blade modifications, such as welding or hard surfacing cutting edges by welding or straightening bent blades, can reduce blade strength and adversely affect blade properties and safety.
- Check that all guards and shields are in place and that all equipment is in good operating condition. This includes PTO driveline, gearbox and implement guards and shields that are used for operator protection.
- Check for properly latched driveline yoke end locking devices.
- Check for damaged or leaky tractor and mower hydraulic systems.
- Check and read safety signs and warning instructions.
- Explain the safety signs and warning instructions to those users or operators who cannot read.

Check The Work Area

Inspect, identify and avoid hazardous conditions in the work area:

- Rough terrain, drop-offs, ditches, potholes steep slopes, stumps, standing water, mud soft soil, slippery conditions, debris and foreign objects.
- Inspect mowing area and remove or mark all foreign objects and debris to be avoided by mower.

Analyze mowing area to determine:

- Best and safest mowing procedure.
- Material type and height to be mowed.
- Operating terrain conditions.
- Using forward travel mowing pattern when possible.

Look Out For The Safety of Others

Before starting equipment:

- Walk around the equipment.
- Check for anyone under, on or near the equipment.
- Clear everyone from these areas.
- Sound a warning.



**USE ROPS
and Seatbelt**

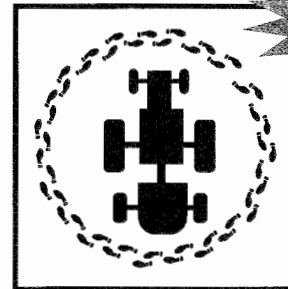

**WALK AROUND
Inspection**

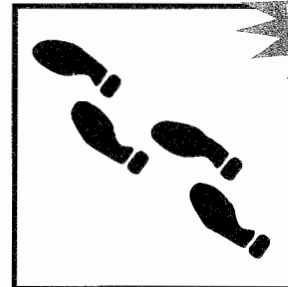

**WALK AROUND
the Worksite**

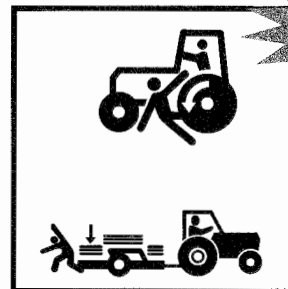

**LOOK OUT
For Others**

Safety – Starting & Testing

USE Three Point Contact



USE ROPS and Seatbelt



USE Proper PTO speed

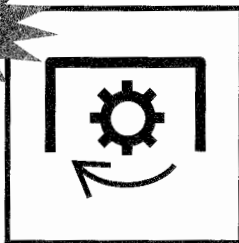

Mounting Tractor Safety

Before mounting:

- Clean shoes and wipe hands.

During mounting and dismounting:

- Use handholds and step plates.
- Never grab steering wheels or controls for handholds.
- Never mount or dismount from a moving tractor.

Tractor And Mower Controls Safety Test

Before starting:

- Fasten and adjust seat belt on your ROPS-equipped tractor.
- Check parking brake for engagement.
- Check PTO disengagement.
- Check all controls for Neutral or Park position.
- Warn others in area before starting tractor.
- Follow tractor manufacturer's recommended starting procedures.

After starting:

- Check all instruments, gauges and indicator lights for normal operation.
- Check all tractor controls, steering and brakes for proper function.
- Repair improperly functioning tractor before using.
- Raise and lower mower for driveline bottoming out or engagement problems.
- Check your equipment for excessive vibration and unusual noises.
- Use proper equipment shutdown practices before inspecting equipment.

Power Takeoff System And Mower Safety

Tractors with dual-speed (540 or 1000 rpm) shiftable PTO systems.

To avoid serious injury or death from failed parts due to mower over speed:

- Be sure to position PTO selector to mower's rated PTO rpm speed.

Tractors with transmission-driven PTO systems.

A rotary mower will have a significant flywheel effect which may continue to propel a tractor with a transmission-driven PTO system.

The tractor should be equipped and operated as follows:

- Install an over-running clutch.
- Give yourself sufficient maneuvering room and time by anticipating turns, stops and speed reductions.

Safety – During Operation

Hitching Mower To Tractor Safety

Three-point hitch-mounted mower safety:

- Refer to mower and tractor manufacturers' manuals.
- Place tractor's hydraulic power lift (rockshaft) selector lever in down position to avoid unexpected movement.
- Explain the hitching procedures to those users or operators who cannot read.

Pull-type hitch-mounted mower safety:

- Refer to mower and tractor manufacturers' manuals.
- Attach only to drawbar hitch.
- Do not attach to tractor's rear axle or three-point hitch arms.
- Adjust tractor drawbar length for 540 or 1000 rpm PTO operation.

Make The Right Start In Mower Safety

Mow only in daylight or good artificial light conditions.

To avoid serious injury or death from mower thrown objects or blade contact:

- Keep chain shields, flexible or solid deflector shields or discharge chutes in place and in good repair.
- Keep everyone several hundred (300) feet from mowing operation.
- Never direct mower discharge toward anyone.
- Keep hands, feet and other body parts away from rotating parts, blades and discharge openings.
- Do not operate mower in transport position.

Mower PTO drive engagement:

- Raise mower to maximum cutting height.
- Engage PTO at low engine rpm.
- Increase engine rpm to mower rated rpm PTO speed.
- Lower mower to desired cutting height.
- Stop and shut down immediately if the mower strikes an obstruction.
- Inspect and repair any mower damage before resuming mowing.
- Do not operate mower with severe vibrations or with unusual noise.

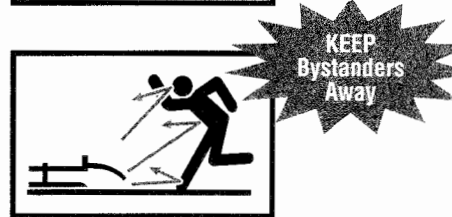
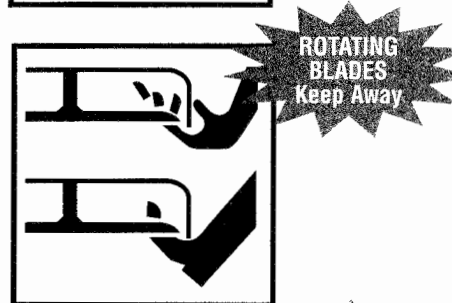
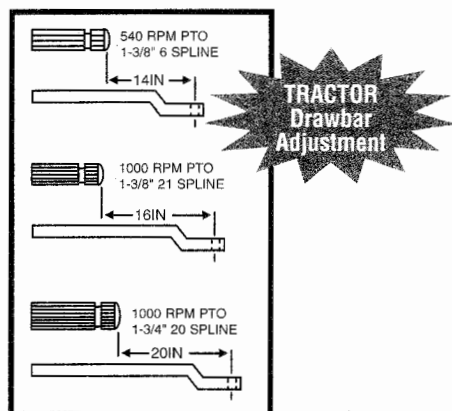

LOOK OUT
For Others

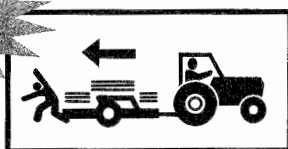

Mowing In Reverse Safety

Avoid mowing in reverse direction when possible.

Do the following when mowing in reverse direction:

- Check for any persons behind mower before reversing direction.
- Use extreme care when reverse direction mowing.
- Maintain rotary mower front and rear safety shields and flail front shields and rear rollers.

MAINTAIN
FLAIL
Rear Roller

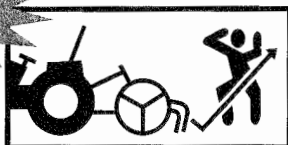

Mowing Ground Speed

Proper ground speed depends on terrain conditions and grass type, density and height to be cut:

- Normal ground speed range is 2 to 5 mph.
- Slower ground speed for mowing tall, dense grass.
- Faster ground speed for mowing medium height, thin grass and under smooth terrain conditions.
- Use slower ground speed for mowing in rough, sloping or unfamiliar terrain.

USE PROPER
Ground Speeds

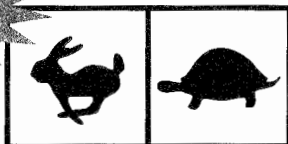

STOP BLADE
Before
Unclogging



Extremely tall grass mowing

- You may need to mow extremely tall grass twice.

First mowing pass:

- Cut grass higher (10-15 inches) to avoid hidden objects.

Second mowing pass:

- Remove debris and objects.
- Cut grass at desired height and 90 degree to the first mowing pass when possible.
- Use proper equipment shutdown practice for your safety before dismounting tractor.

PROVIDE
Adequate
Clearance for
Mower Swing

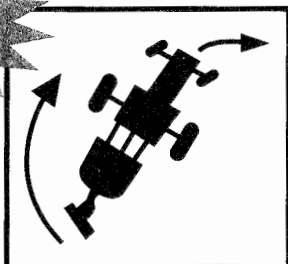

Watch equipment clearances

Three-point hitch and side mounted mowers have a larger turning arc than pull-type mowers. Allow sufficient clearance for safe turning.

NEVER STAND
On Mower
Keep Away

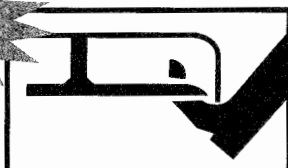

Under Mount Mower Safety

When mowing with an under mount mower:

- Keep removable discharge chute in place and over discharge opening.
- Never stand on an operating mower housing.
- Distribute grass clipping with discharge chute facing mowed area.
- Use proper equipment shutdown practice before clearing clogged mower or discharge chute.

KEEP CHUTE
In Place

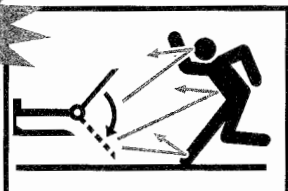

Wing Or Boom Type Mower Overhead Obstruction Hazards and Risks

Check for overhead obstructions with raised wings or boom-type mowers to avoid serious injury or death by contact with:

- Electrical power lines.
- Low tree limbs.
- Other overhead obstructions.

Wing And Side Mount Mowers Safety

When mowing with wing and side-mount mowers:

Raised wing positions reduces shielding protection and increases the thrown object and blade contact hazard risks.

To avoid serious injury or death by thrown objects or blade contact from raising and lowering wings during mowing operations:

- Do not mow with bystanders in mowing area.
- Be sure no one is near mower while raising or lowering wings.
- Keep the exposed rotating wing blade time to a practical minimum during a raised wing mowing operations.
- Stop mowing if persons enter into mowing area.
- Only raise wing to clear objects in the mowing path or to match ground slope.
- Disengage wing drive for extended periods of mowing with raised wings.
- Lower raised wing to ground after clearing object or ground slope conditions.
- Allow all mower blades to stop rotating before raising wing sections during other operations.

Ditch Bank Mowing Safety

Use extreme care when mowing ditch banks. Watch for washouts, eroded areas and mowing obstructions along the ditch banks. Hitting obstructions with side-mount or boom mowers may swerve the tractor's front end toward the ditch.

Raised wing and boom-type mower ditch bank operations may reduce the mower's thrown object shielding effectiveness for the mower operator's protection.

To increase operator protection from thrown objects during ditch bank operations:

- Use enclosed ROPS cabs, special protective enclosures and other operator shielding when performing these operations.
- Inspect mowing area and remove or mark all foreign objects and debris to be avoided by mower.



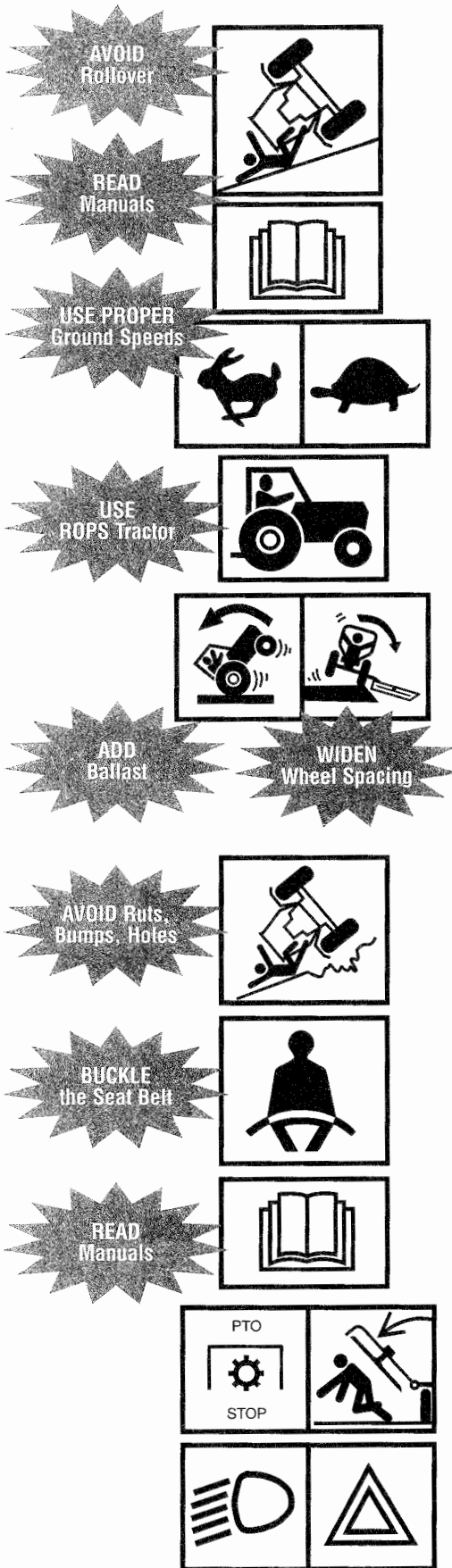

Mowing Uneven Terrain Safely

The tractor and mower stability is reduced on slopes and uneven terrain.

You can prevent tractor and mower overturns and maintain equipment stability control by:

- Reviewing tractor and mower operator's manuals for operating safety practices on slopes and uneven terrain conditions. Explain the practices to those users and operators who cannot read.
- Avoiding extremely steep slope operations.
- Using extreme care to maintain control over your equipment when operating in these conditions.
- Increasing tractor stability by adding wheel weights and increasing wheel spacing (Refer to tractor operator's manual for recommendations)
- Using ROPS and seat-belt-equipped tractor for operator safety during mowing operations.
- Maintaining minimum ground speed.
- Making wide and gradual turns.
- Avoiding sudden starts, stops, and turns when operating up, down, or across slopes.
- Not raising rear-mount or side-mount mowers or mower wings from the ground during these operations .
- Keeping alert for holes, bumps, ruts, rocks, stumps or other obstructions that could overturn tractor and mower.
- Avoiding slippery ground conditions that could overturn tractor and mower.
- Avoiding tractor and mower "hang up" by diagonal passing through sharp dips and drops.

Use extreme care in maintaining equipment stability during all uneven terrain and slope mowing operations. You are the final judge as to any slope that can be safely negotiated.

Equipment Road Transporting Safety

If equipment is to be driven on public roads:

- Refer to tractor and mower manufacturers' operator's manuals for instructions.
- Explain the instructions to those users or operators who cannot read.
- Check local regulations for required equipment markings, lights, flashers, etc., while traveling on public roads. Lights are required on mowers that obscure tractor taillights and/or warning lights.

Before transporting on public roads:

- Disengage PTO to mower.
- Raise mower into transport position.
- Lock wings up into transport position with locking devices on wing-type and side-mounted mowers.
- Attach safety chain between pull-type mower and tractor.
- Make sure lights, flashers, reflectors and SMV are in place and visible.
- Check SMV (Slow-Moving Vehicle) emblem for visibility to any rear approaching vehicle.

While transporting on public roads:

- Obey all local traffic regulations.
- Approach intersections with caution.
- Observe speed and traffic control signs.
- Avoid panic stops and sharp turns.

Parking Safety

Park equipment at:

- Designated or out-of-traffic areas.
- Preferably level ground locations.

Sloping ground parking locations:

- Position equipment across slope.
- Set parking brakes.
- Lower mower to ground.
- Block tractor wheels.

Before temporarily parking and leaving disabled equipment near traffic areas:

- Remove equipment from public roads.
- Set out warning flags
- Use tractor flashers.

Safety – During Shutdown

Use Proper Equipment Shutdown Practices For Your Safety

Refer to tractor and mower manufacturer’s operator manual(s) for recommend shutdown procedures. Explain the procedures to those users or operators who cannot read.

Make proper equipment shutdown procedures an important habit to practice. Follow these safety practices before dismanting tractor:

- Disengage PTO clutch and transmission drive.
- Idle engine for gradual cooling.
- Place the controls in PARK or NEUTRAL.
- Set the parking brake.
- Lower mower to ground.
- Lower wings of wing-type mowers to ground.
- Shut off engine.
- Wait for all moving parts to stop before equipment inspections, adjustments or repairs.
- Relieve hydraulic pressure by moving hydraulic controls several times in all directions.
- Lock ignition and remove key when equipment is to be inspected, repaired, adjusted or unattended.
- Lock anti-vandalism covers and closures when equipment is unattended.
- Dismount carefully maintaining three-point contact.

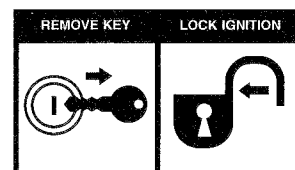
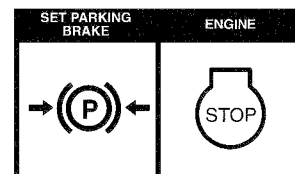
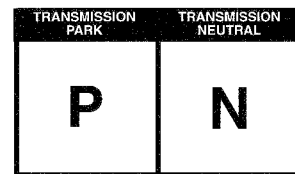
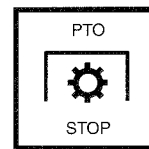
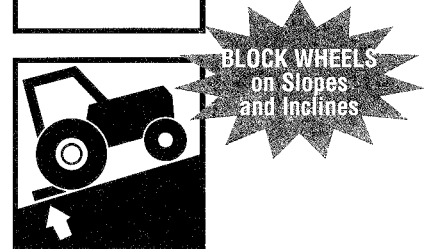
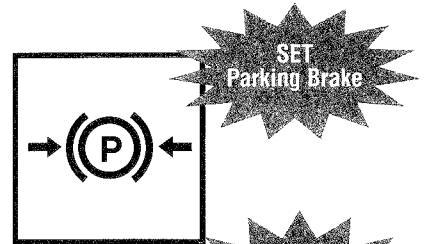
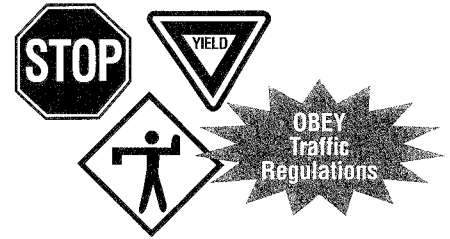

WAIT For Moving Parts to Stop Before Dismount



USE Three Point Contact



MAINTAIN Equipment

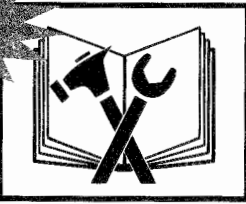

FOLLOW

Maintenance Schedule



Dismounting Tractor Safely

Before dismounting tractor:

- Use proper equipment shutdown practice for your safety.
- Lower implement to the ground, stop engine and PTO, set brakes, allow all moving parts to stop, and remove key before dismounting from tractor.
- Never dismount from moving equipment.
- Never jump from machines.
- Dismount carefully.
- Check for slippery steps
- Keep feet and hands away from controls.
- Use handholds and steps during dismount.
- Face machine and use 3 point contact (2 hands, 1 foot or 2 feet, 1 hand).

Safety – During Maintenance

Maintenance Safety

Do the following for your safety before performing any maintenance, repairs or service procedures:

- Follow proper equipment shutdown practice.
- Wear all the protective clothing and personal safety devices necessary to safely perform the job.
- Refer to your manufacturer's manuals for proper maintenance, repair and service procedures. Explain the procedures to those users and operators who cannot read.

Stored energy sources (electrical, mechanical, hydraulic, pneumatic, chemical, thermal, etc..) must be either locked, blocked, relieved, disconnected, stopped, secured, neutralized, controlled or reduced to a practical minimum before any maintenance, repair or service procedures can be done safely.

Some basic safety practices to prevent potential injuries from energy releasing sources:

- Disengage PTO before shutting off engine.
- Place controls in PARK or NEUTRAL before shutting off engine.
- Set parking brake or block wheels.
- Allow all moving parts to stop.
- Lower mower to ground.
- Lower wings to ground on wing-type mowers.
- Shut off tractor engine.
- Lock ignition and remove key.
- Look and listen for evidence of moving parts before opening shields.
- Securely support or block-up mower before working underneath mower or other lifted components.
- Securely support, block-up, or lock-up mower wings with locking devices before working near or underneath a wing-type mower.
- Relieve hydraulic system pressure by moving controls several times in all directions.
- Relieve pressure before disconnecting or disassembling any pressurized system.
- Block or relieve spring pressure before disassembling any spring-loaded mechanism.
- Securely support or block up any elevated machine component before working on it.
- Avoid flames, sparks, or smoking near any fuels.

Mower Manufacturer Parts and Your Safety

Most mower manufacturers use special fasteners and specially designed parts to meet mowing operations requirements.

Critical safety-related parts (Self-locking blade bolts, blades, pins, shields or other special items) have specific strength, design and fit requirements for the make and model mower you are using.

Modifications or repair parts not approved by the mower manufacturer can cause serious safety hazard exposure risk to you and others.

TO AVOID SERIOUS INJURY OR DEATH FROM UNAPPROVED PARTS OR MODIFICATIONS:

- Do not substitute common hardware for self-locking blade bolts or other special part items.
- Do not substitute blades, pins, shields or other critical safety-related parts.
- Do not use grade 5 or 8 bolts to replace grade 2 shear bolts.

FOLLOW THE SAFETY PRACTICE OF ALWAYS CHECKING THE MOWER FOR PROPER FUNCTION AFTER ALL ADJUSTMENTS REPAIRS OR SERVICE.

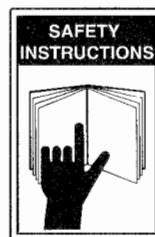
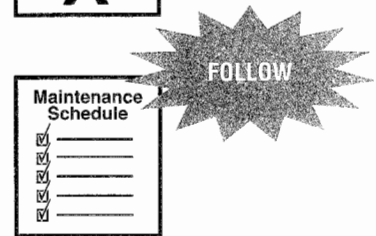
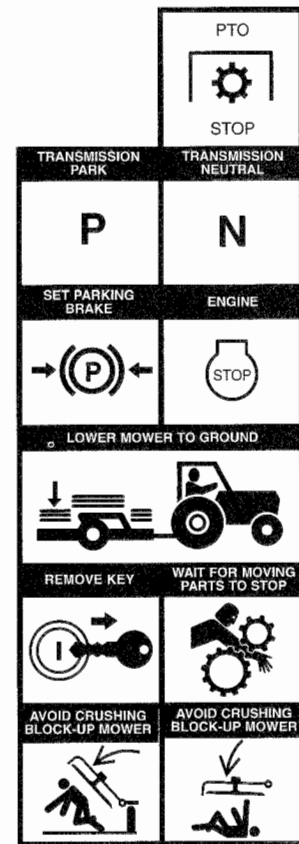

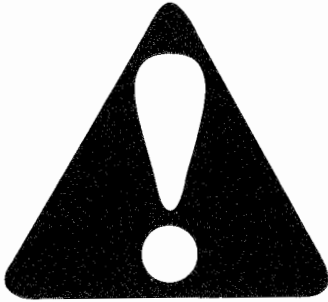

One Final Word



You have just finished reading the Mower Safety Manual. It is impossible for this manual to cover every potentially hazardous situation you may encounter. But, your knowledge of these safety precautions and your adherence to the basic rules of safety will help build good judgment in all situations. Our objective is to help you develop good safety habits and make you a better mower operator. The mower safety manual, safety precautions and basic rules of safety must be explained to those users or operators who cannot read.

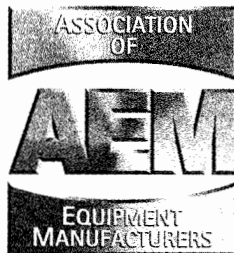

111 E. Wisconsin Avenue • Milwaukee, Wisconsin 53202 U.S.A.
www.aem.org

For information on additional copies of this and
other safety manuals, call 800-369-2310



Segadora industrial y agrícola

manual de
seguridad

*para operadores
y mecánicos*

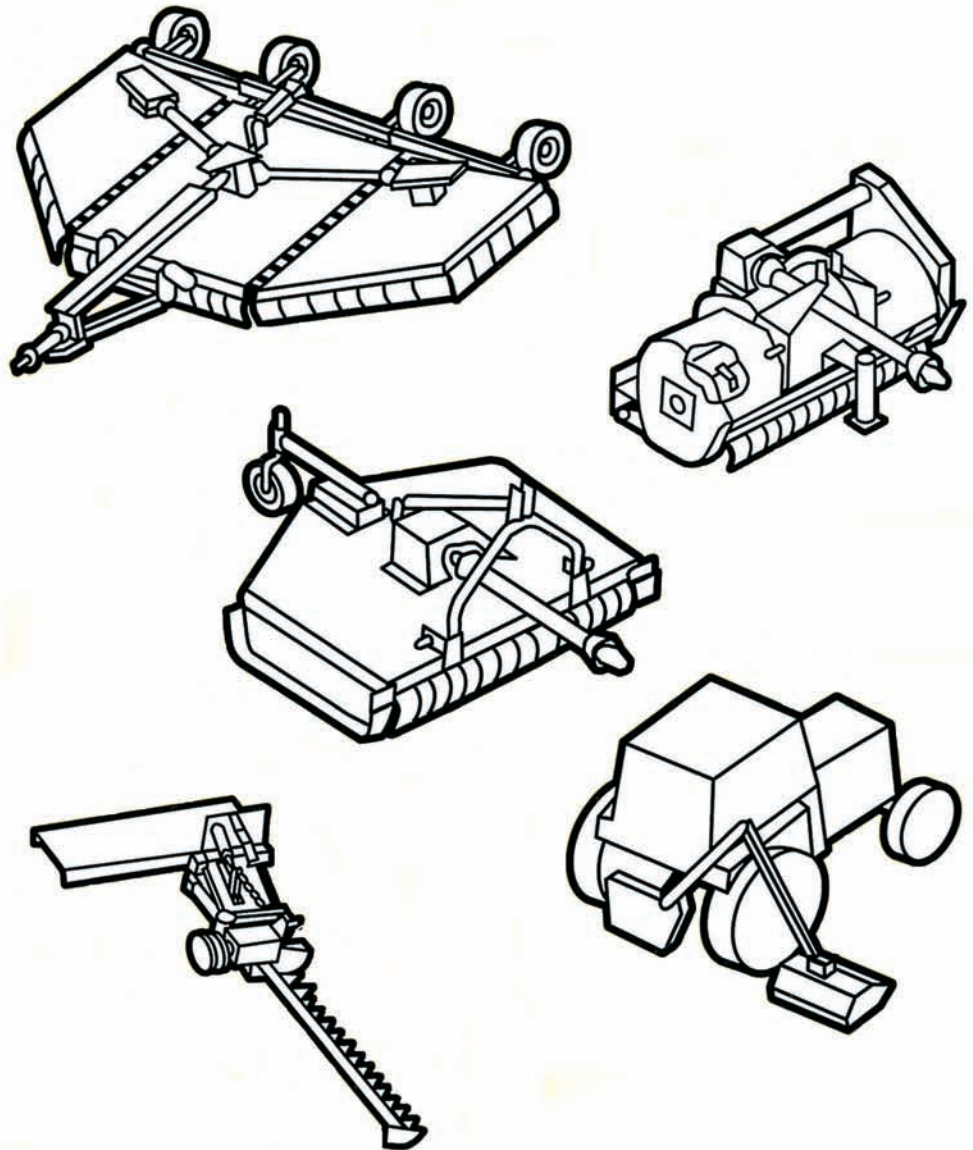

111 E. Wisconsin Avenue • Milwaukee, Wisconsin 53202 U.S.A.
www.aem.org

Contenido

Reconocimiento	2
Introducción	3
Palabras para el usuario	3
Alerta de seguridad	4
Segadoras industriales y agrícolas.....	4
Sea un operador responsable	5
Manejo seguro de riesgos y peligros.....	6
Cumpla con un programa de seguridad.....	11
Seguridad previa a la operación	11
Seguridad durante el arranque y prueba	13
Seguridad durante la operación	14
Seguridad durante la parada	18
Seguridad durante el mantenimiento	19
Palabra final	21

Reconocimiento

Deseamos extender nuestro reconocimiento a los miembros de del Association of Equipment Manufacturers por sus contribuciones para la preparación de este manual de seguridad.

Derechos de autor

© 2000 Equipment Manufacturers Institute. Todos los derechos reservados. Revisado 08.2003

Introducción

El propósito de este manual de seguridad es señalar algunas de las situaciones básicas de seguridad que pueden ocurrir durante la operación y mantenimiento de su máquina y sugerir los métodos posibles para tratar estas situaciones. Este manual NO es un sustituto de el (los) manual(es) del fabricante.

Pueden ser necesarias algunas precauciones adicionales, o algunas instrucciones no pueden aplicar, dependiendo del equipo, dispositivos de fijación, y las condiciones del lugar de trabajo o del área en que se realiza el servicio. El fabricante no tiene control directo sobre las aplicaciones, operación, inspección, lubricación o mantenimiento de la máquina. Por lo tanto, es **SU** responsabilidad practicar buenas medidas de seguridad en estas áreas.

La información proporcionada en este manual sirve como complemento de los detalles de información específicos de su máquina que están incluidos en el (los) manual(es) del fabricante. La información adicional que pueda afectar la operación segura de su máquina puede estar incluida en las etiquetas de seguridad o en los requisitos del seguro, programas de seguridad del empleador, códigos de seguridad, leyes locales del estado/provincia y leyes nacionales, reglas y reglamentos.

IMPORTANTE: si usted no tiene el (los) manual(es) del fabricante de su máquina específica, obtenga un manual de reemplazo con su empleador, distribuidor de equipo o el fabricante de su máquina. Mantenga este manual de seguridad y el (los) manual(es) del fabricante con su máquina.

Palabras para el usuario

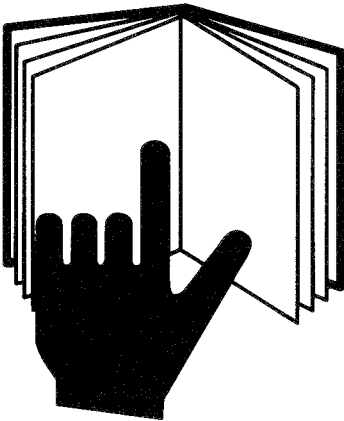

Usted tiene la responsabilidad de leer y comprender este manual de seguridad y el (los) manual(es) del fabricante, antes de operar esta máquina. Este manual de seguridad lo guía paso a paso a lo largo de su día de trabajo. El manual de seguridad, el (los) manual(es) del fabricante, avisos de seguridad (calcomanías) y precauciones de seguridad, deben explicarse a los usuarios u operadores que no puedan leer el material.

Adicionalmente al diseño y configuración del equipo el **CONTROL DEL PELIGRO** y la **PREVENCIÓN DE ACCIDENTES** dependen de la conciencia, preocupación, prudencia y capacitación adecuada de los propietarios y operadores durante la operación, transporte, mantenimiento y almacenamiento del equipo.

Recuerde que **USTED** es la clave para mantener la seguridad. Las buenas prácticas de seguridad no lo protegen solamente a usted sino que también a las personas que lo rodean. Estudie este manual y el (los) manual(es) del fabricante para su máquina específica. Hágalos una parte integral de su programa de seguridad. Recuerde que este manual de seguridad está escrito únicamente para segadoras industriales y agrícolas.

Practique todas las precauciones de seguridad usuales y acostumbradas en el trabajo y más que todo – recuerde que la seguridad depende de USTED. Solamente USTED puede evitar las lesiones graves o la muerte debidas a prácticas inseguras.

Advertencia de seguridad

Símbolo

Este símbolo de alerta de seguridad significa:

“¡ATENCIÓN! ¡MANTÉNGASE ALERTA! ¡SU SEGURIDAD ESTÁ INVOLUCRADA!”



El símbolo de alerta de seguridad identifica los mensajes de seguridad importantes en el equipo, en los avisos de seguridad, en los manuales y en otros lugares. Cuando usted vea este símbolo, esté alerta a la posibilidad de muerte o lesiones. Siga las instrucciones en el aviso de seguridad.

Palabras de señales

Las palabras de señales son palabras específicas que regularmente se encontrarán en las calcomanías de seguridad en este equipo o en otros equipos en el lugar de trabajo. Estas palabras tienen el objetivo de alertar a la persona que las vea de la presencia y el grado relativo de un riesgo.



Esta palabra de señal indica una situación de riesgo inminente que si no es evitado podrá resultar en la muerte o lesiones graves.



Esta palabra de señal indica una situación potencialmente riesgosa que si no se evita podría resultar en la muerte o lesiones graves.



Esta palabra de señal indica una situación potencialmente riesgosa que si no se evita podría resultar en lesiones menores o moderadas.

- LOS ACCIDENTES PUEDEN LISIAR Y CAUSAR LA MUERTE.
- LOS ACCIDENTES SON COSTOSOS.
- LOS ACCIDENTES PUEDEN EVITARSE.

Segadoras industriales y agrícolas

Es una segadora para cortar pasto, triturar residuos de cultivos, cortar maleza para la limpieza de terrenos, vías navegables, derechos de paso, cortes en los bordes de los caminos o carreteras.

TIPOS DE SEGADORAS INDUSTRIALES Y AGRÍCOLAS:

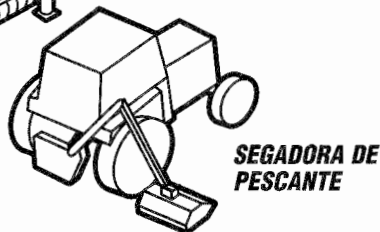
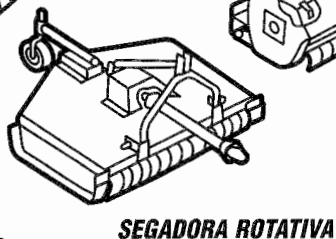
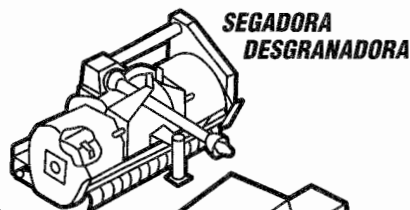

Sea un operador responsable



Para la operación segura de su equipo usted debe ser un operador responsable. Un operador responsable debe comprender claramente las instrucciones escritas proporcionadas por el fabricante ser capacitado – incluyendo la operación real del equipo y el conocimiento de las reglas y reglamentos de seguridad del lugar de trabajo.

Las medicinas y el alcohol pueden y afectarán el estado de alerta y coordinación del operador, por lo tanto, afectarán la habilidad del operador para operar el equipo en forma segura. Un operador **NUNCA** debe usar medicinas que puedan afectar su estado de alerta, juicio y coordinación; ni beber alcohol mientras opera equipo motorizado incluyendo tractores y segadoras. Un operador que use medicamentos por prescripción médica o de venta libre debe consultar con un médico profesional para conocer sobre cualquier efecto secundario que podría limitar su habilidad para operar este equipo en forma segura. **NUNCA** permita que alguien opere este equipo cuando estén afectados su estado de juicio alerta o de coordinación.

Protéjase usted mismo

Use toda la ropa protectora y los dispositivos de seguridad personal que se le proporcionen o que sean los indicados para las condiciones de trabajo.

Usted puede necesitar:

- Casco protector
- Zapatos de seguridad
- Anteojos de seguridad con protección lateral, gafas protectoras o protector facial
- Guantes extrafuertes
- Protección auditiva
- Ropa reflectora
- Equipo para clima húmedo
- Respirador o máscara filtrante

Use ropa apropiada para las condiciones del trabajo.

Siempre conozca cómo obtener ayuda en caso de una emergencia. Conozca donde encontrar y cómo usar los equipos de primeros auxilios y el extintor de incendios/sistema de supresión de incendios.



**Manténgase alerta. Evite los accidentes.
No conozca la seguridad en la forma más difícil.**

Manejo seguro de riesgos y peligros

Adicionalmente al diseño y configuración del equipo, el **CONTROL DEL PELIGRO** y la **PREVENCIÓN DE ACCIDENTES** dependen de la conciencia, preocupación, prudencia y capacitación adecuada de los propietarios y operadores durante la operación, transporte, mantenimiento y almacenamiento del equipo.

EL MANEJO SEGURO DE RIESGOS Y PELIGROS ES UN ELEMENTO ESENCIAL PARA LOS PROPIETARIOS Y OPERADORES RESPONSABLES DE TRACTORES Y SEGADORAS.

REVISE EL MANEJO SEGURO DE LOS PELIGROS Y RIESGOS ENUMERADOS A CONTINUACIÓN.

Peligro de objetos despididos

EXISTE LA POSIBILIDAD DEL RIESGO DE LESIONES A LOS OPERADORES Y TRANSEÚNTES CAUSADAS POR OBJETOS DESPIDIDOS DURANTE LA OPERACIÓN DE LA SEGADORA POR LOS SIGUIENTES:

OBJETOS (PIEDRAS, ESCOMBROS, HOJAS ROTAS DE LA SEGADORA, PERNOS DE LA HOJA, CABLES, CADENAS, ALAMBRE, ETC.) DESPIDIDOS POR LA SEGADORA.

Dispositivos protectores del equipo y prácticas de seguridad recomendadas

La cubierta de la segadora y los dispositivos protectores no pueden evitar que escapen todos los objetos o desechos del área cerrada de la hoja en todas las condiciones de segado. Es posible que los objetos escapen y se desplacen cientos de pies (300 [100 m]).

PRÁCTICAS DE SEGURIDAD RECOMENDADAS

Lea los manuales del operador del fabricante para conocer las prácticas de seguridad recomendadas durante la operación. Explique las prácticas a los usuarios u operadores que no puedan leer.

PARA AYUDAR A EVITAR LESIONES GRAVES O LA MUERTE CAUSADAS POR OBJETOS QUE GOLPEEN AL OPERADOR U OTRAS PERSONAS HAGA LO SIGUIENTE:

SEGURIDAD DE TRANSEÚNTES

- Mantenga a los transeúntes a varios cientos de pies (300 [100 m]) del área segada.

SEGURIDAD PROPORCIONADA POR LOS DISPOSITIVOS PROTECTORES DEL EQUIPO

Para contener, desviar o reducir los objetos despididos del área cerrada de la hoja:

- Mantenga la cadena, blindajes deflectores flexibles o sólidos colocados en la parte delantera y trasera de la cubierta de la segadora, en su lugar y en buen estado de funcionamiento.
- No opere el equipo con los blindajes para objetos despididos dañados o sin que estén colocados en su lugar.

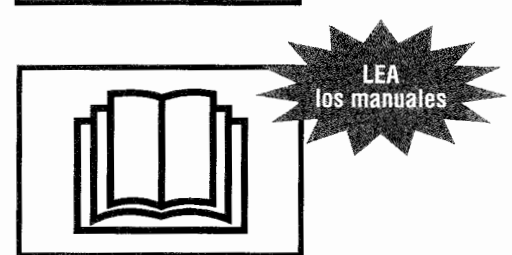

SEGURIDAD DEL OPERADOR

La operación de las segadoras con las alas levantadas, de montaje lateral y pescante, pueden reducir la efectividad del blindaje para proteger al operador contra los objetos despedidos de la segadora.

Haga lo indicado a continuación para aumentar la protección del operador contra los objetos despedidos durante las operaciones de segado:

- Use cabinas cerradas con una estructura de protección contra vuelcos (ROPS), cubiertas protectoras especiales, mallas u otros dispositivos para proteger al operador cuando efectúa estas operaciones.

SOBREPASAR LAS VELOCIDADES RECOMENDADAS PARA LA TOMA DE FUERZA (PTO)

No sobrepase las velocidades recomendadas por el fabricante para la toma de fuerza (PTO).

Las velocidades excesivas de la toma de fuerza (PTO) pueden causar:

- Fallo de la hoja
- Escape de objetos a velocidad alta u hojas rotas despedidas del área cerrada de la hoja de la segadora.
- Fallos potenciales de la línea de transmisión de 540 rpm cuando se opera a velocidades de 750 a 1000 rpm.

OTRAS PRÁCTICAS DE SEGURIDAD:

- Nunca debe operar la segadora con hojas rotas, dobladas, faltantes o que estén extremadamente desgastadas.
- Antes de segar retire los desechos y objetos extraños para evitar que sean recogidos y despedidos por la segadora.
- No debe operar la segadora durante el transporte o en posición de ala levantada.

PRÁCTICAS DE MANTENIMIENTO RECOMENDADAS

Lea los manuales del operador del fabricante para conocer sobre la inspección y mantenimiento de las defensas de la cadena y blindaje deflector flexible o sólido:

- Reemplace las defensas desgastadas o dañadas y los demás blindajes antes de segar.
- Use solamente las defensas y blindajes de reemplazo del fabricante. Otras defensas o blindajes pueden no encajar, o los materiales pueden no ser adecuados para cumplir con los requisitos de resistencia del equipo.
- Reemplace las calcomanías desgastadas o dañadas y las instrucciones de advertencia.
- Explique las instrucciones de inspección y mantenimiento a los usuarios u operadores que no puedan leer.

USE cabinas cerradas con una estructura protectora contra vuelcos (ROPS) o cubiertas protectoras

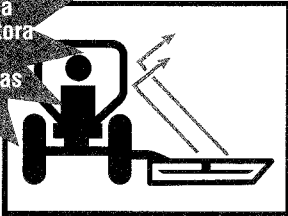

USE la velocidad apropiada de la toma de fuerza (PTO)

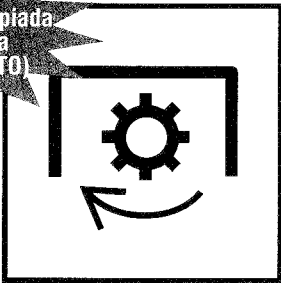

DÉ MANTENIMIENTO a su equipo

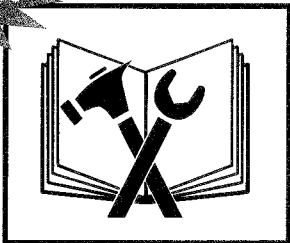

Peligros y riesgos de las hojas rotativas y línea de transmisión

EXISTE EL RIESGO DE POSIBLES LESIONES A LOS OPERADORES DE LA SEGADORA Y TRANSEÚNTES DURANTE LAS OPERACIONES DE SEGADO CAUSADAS POR LO SIGUIENTE:

- CONTACTO DEL CUERPO CON LAS HOJAS ROTATIVAS.
- ENREDO DEL CUERPO CON LAS LÍNEAS DE TRANSMISIÓN Y PIEZAS ROTATIVAS.

Dispositivos protectores del equipo y prácticas de seguridad recomendadas

PRÁCTICAS DE SEGURIDAD RECOMENDADAS

Lea los manuales del operador del fabricante para conocer las prácticas de seguridad recomendadas. Explique las prácticas a los usuarios u operadores que no puedan leer. Para evitar el riesgo de lesiones graves o la muerte causadas por el contacto con la hoja en movimiento, línea de transmisión o enredo de los operadores u otras personas haga lo siguiente:

SEGURIDAD DE TRANSEÚNTES

- No debe operar cerca de transeúntes.
- Mantenga a otras personas a varios cientos de pies (300 [100 m]) del área de segado.

PRÁCTICAS DE SEGURIDAD DEL OPERADOR

- No permita pasajeros en el tractor o segadora. Asegúrese el cinturón de seguridad durante el segado.
- Use la práctica de parada del equipo apropiada antes de dar servicio, ajustar, limpiar o eliminar las obstrucciones de la segadora.
- Manténgase alejado de las hojas rotativas, piezas y líneas de transmisión.
- Nunca arranque el motor del tractor mientras esté de pie al lado del equipo.
- Solamente arranque el motor del tractor cuando esté sentado en el asiento del operador con el cinturón de seguridad abrochado.

PRÁCTICAS DE SEGURIDAD RECOMENDADAS PARA DEFENSAS Y BLINDAJES DE LA LÍNEA DE TRANSMISIÓN

- Mantenga las líneas de transmisión y otros blindajes colocados y en buen estado.
- No debe operar la segadora cuando las defensas, defensas de la línea de transmisión u otros blindajes hagan falta o estén dañados.

PRÁCTICAS DE SEGURIDAD RECOMENDADAS

Lea los manuales del operador del fabricante para conocer las instrucciones sobre defensas, defensas de la línea de transmisión y otros blindajes:

- Reemplace las defensas, defensas de la línea de transmisión y otros blindajes desgastados o dañados antes de segar.
- Use solamente defensas y blindajes de reemplazo hechas por el fabricante. Otras defensas o blindajes pueden no encajar o ser de materiales inadecuados que no cumplan con los requisitos de resistencia del equipo.
- Reemplace las calcomanías e instrucciones de advertencia desgastadas o dañadas.
- Explique las instrucciones de inspección y mantenimiento a los usuarios u operadores que no puedan leer.



EVITE enredarse



EVITE las piezas rotativas



LEA los manuales



ASEGÚRESE el cinturón de seguridad



NO LLEVE PASAJEROS



EVITE el ser atropellado



DÉ MANTENIMIENTO a su equipo

EVITE vuelcos

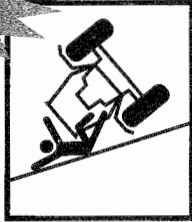

USE la estructura contra vuelcos (ROPS) del tractor



LEA los manuales

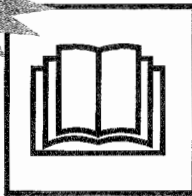

AGREGUE balasto



AUMENTE el espacio entre las ruedas y AGREGUE balasto en el lado contrario



ASEGURESE el cinturón de seguridad



EVITE EL APLASTAMIENTO asegure el ala



Peligros y riesgos de rodamiento o vuelco del tractor y segadora

EXISTE UN RIESGO DE LESIONES POSIBLES AL OPERADOR POR RODAMIENTO O VUELCO DE LA SEGADORA DURANTE LAS OPERACIONES DE SEGADO POR LO SIGUIENTE:

- TERRENO ACCIDENTADO, PENDIENTES INCLINADAS, AGUJEROS, BACHES, SURCOS, PIEDRAS, TRONCOS U OTRAS OBSTRUCCIONES QUE PODRÍAN VOLCAR EL TRACTOR Y SEGADORA.
- VELOCIDADES ABSOLUTAS EXCESIVAS PARA ESTAS CONDICIONES DE TERRENO.

Dispositivos protectores del equipo y prácticas de seguridad recomendadas

Cuando sea posible, retire los troncos, piedras, etc., o márkuelos claramente con las demás obstrucciones para evitar vuelcos, averías y condiciones de conducción peligrosas. Tenga extremo cuidado para mantener el control sobre el equipo cuando opere en terrenos con estas condiciones.

ESTRUCTURAS CONTRA VUELCO (ROPS) RECOMENDADAS PARA TRACTORES

Un tractor equipado con una estructura contra vuelcos (ROPS) o cabina ROPS cerrada y cinturón de seguridad para la seguridad del operador, es esencial para la protección adicional del operador, cuando opera en terrenos con estas condiciones

AJUSTES RECOMENDADOS PARA LA ESTABILIDAD DEL TRACTOR

Lea el manual del operador del tractor para conocer los ajustes para aumentar la estabilidad del tractor:

- Agregue pesas o balasto a las ruedas delanteras y traseras.
- Ajuste el espacio entre las ruedas al ancho máximo.
- Agregue contra balasto en el lado contrario a las segadoras de montaje lateral y de pescante.
- Explique los ajustes a los usuarios u operadores que no puedan leer.

PRÁCTICAS DE SEGURIDAD RECOMENDADAS

Lea los manuales del operador del fabricante para conocer las prácticas de seguridad de operación recomendadas. Explique las prácticas a los usuarios u operadores que no puedan leer. **Para evitar lesiones graves o la muerte del operador por el vuelco del tractor y segadora, haga lo siguiente:**

- Abroche firmemente el cinturón de seguridad cuando seque con tractores equipados con una estructura contra vuelcos (ROPS).
- Evite la velocidad absoluta excesiva de acuerdo con las condiciones del terreno.
- Evite los arranques, paradas y virajes repentinos cuando opere subiendo, bajando o atravesando pendientes.
- Evite las condiciones de terreno resbaloso.
- Haga virajes anchos y graduales.
- Planifique segar cuesta abajo en pendientes inclinadas para evitar los vuelcos.

Peligros y riesgos de aplastamiento por una segadora o piezas desprendidas

EXISTE EL RIESGO DE UNA LESIÓN POR APLASTAMIENTO PARA LOS OPERADORES Y OTRAS PERSONAS DURANTE LAS OPERACIONES DE SEGADO DEBIDO A LO SIGUIENTE:

- SEGADORA O EQUIPO DESPRENDIDO DEBIDO A FALLO DEL SISTEMA HIDRÁULICO.
- FALLO EN DAR SOPORTE, BLOQUEAR O ASEGURAR COMPLETAMENTE LA SEGADORA O PIEZAS DEL EQUIPO.

Dispositivos protectores del equipo y prácticas de seguridad recomendadas

Lea los manuales del operador del fabricante para conocer las prácticas de seguridad de operación recomendadas. Explique las prácticas a los usuarios u operadores que no puedan leer. **Para ayudar a evitar lesiones serias o la muerte de los operadores y otras personas causadas por la caída de la segadora o piezas de equipo, haga lo siguiente:**

PRÁCTICAS DE SEGURIDAD RECOMENDADAS

Antes de trabajar cerca o debajo de la segadora o piezas de equipo en posición levantada:

- Use la práctica de parada del equipo apropiada antes de dar servicio, ajustar, limpiar o eliminar las obstrucciones de la segadora.
- Soporte o coloque bloques firmemente debajo de la segadora o piezas de equipo.
- En las segadoras de tipo ala coloque bloques o asegure firmemente las alas con los seguros o baje al suelo la segadora o piezas del equipo.
- Use los seguros de transporte cuando transporte la segadora en caminos públicos.

Peligros y riesgos por la fuga de fluido hidráulico a presión alta

EXISTE UN RIESGO PARA LOS OPERADORES DE SEGADORAS Y OTRAS PERSONAS DE UNA POSIBLE INYECCIÓN DE FLUIDO A PRESIÓN ALTA O GANGRENA CAUSADA POR LA INYECCIÓN EN LA PIEL DE ACEITE HIDRÁULICO O DIESEL.

PARA EVITAR LA GANGRENA, EL FLUIDO INYECTADO DEBE SER ELIMINADO QUIRÚRGICAMENTE EN POCAS HORAS, POR UN MÉDICO FAMILIARIZADO CON ESTE TIPO DE LESIÓN.

PRÁCTICAS DE SEGURIDAD RECOMENDADAS

Lea los manuales del operador del fabricante para conocer las prácticas de seguridad recomendadas. Explique las prácticas a los usuarios u operadores que no puedan leer. Las fugas de fluido a presión alta por agujeros minúsculos pueden ser casi invisibles.

Para ayudar a evitar lesiones serias o la muerte haga lo siguiente:

- Busque las fugas con pedazos de cartón o madera.
- No use las manos para verificar la presencia de fugas.
- Descargue la presión del sistema antes de desconectar los conductos.
- Antes de aplicar presión al sistema:
 - Revise que los conductos, tuberías y mangueras no estén dañados.
 - Revise que las conexiones estén apretadas.
- Antes de operar los sistemas presurizados:
 - Descargue el aire del sistema.
 - Haga referencia al (los) manual(es) del operador del fabricante para obtener instrucciones.
 - Explique los procedimientos a los usuarios u operadores que no puedan leer.

Peligros y riesgos durante el llenado de combustible del tractor

Para evitar las lesiones serias o la muerte por incendio durante el llenado:

- Apague el motor y la ignición.
- Nunca llene el tanque de combustible cerca de llamas descubiertas.
- Nunca fume mientras llena combustible.
- Evite las chispas causadas por la electricidad estática poniendo a tierra la boquilla del combustible contra el cuello de llenado del tanque.
- Evite sobrellenar el tanque o derramar el combustible.
- Limpie inmediatamente el combustible derramado.
- Siempre vuelva a colocar la tapa del combustible.

Para evitar lesiones serias o la muerte causadas por las emanaciones del escape del motor:

- Ventile adecuadamente los espacios cerrados antes de arrancar el motor.



LEA los manuales



EVITE EL APLASTAMIENTO coloque bloques o soportes seguros en la segadora



FLUIDO A PRESIÓN ALTA puede inyectarse en el cuerpo



LEA los manuales

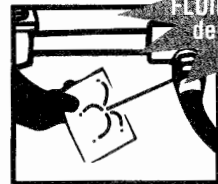

EVITE LA INYECCIÓN DE FLUIDO use un pedazo de cartón, no use las manos



EVITE los incendios y las explosiones

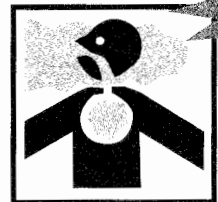

EVITE las emanaciones del escape

Cumpla con un programa de seguridad



LA SEGURIDAD ES IMPORTANTE PARA LOS PROPIETARIOS Y OPERADORES RESPONSABLES DE TRACTORES Y SEGADORAS. HAGA LO SIGUIENTE PARA SU SEGURIDAD DURANTE LA OPERACIÓN DE SEGADO:

SEA UN OPERADOR CAPACITADO HACIENDO LO SIGUIENTE:

- Leyendo, comprendiendo y obedeciendo las instrucciones escritas del fabricante en el (los) manual(es) del operador y avisos de seguridad en la segadora y tractor.
- Recibiendo capacitación operativa para la segadora y tractor.
- Solicitando a su distribuidor de equipo o supervisor que le explique lo que usted no comprende.
- Explicando las instrucciones escritas en el (los) manual(es) del operador y avisos de seguridad (calcomanías) en la segadora y tractor a los usuarios u operadores que no puedan leer.

Seguridad previa a la operación

Conozca las reglas y reglamentaciones de seguridad del lugar de trabajo

Pregunte a su supervisor sobre las reglas de seguridad de operación del equipo que usted deberá obedecer.

Algunas reglas para su seguridad y la de los demás:

- Un tractor equipado con una estructura contra vuelcos (ROPS) es necesario para la protección del operador durante las operaciones de segado.
- Conozca la capacidad y características de operación de la segadora y tractor.
- Nunca altere o desmonte el equipo de seguridad.
- Nunca permita que niños o personas no capacitadas operen una segadora o tractor.
- Nunca permita pasajeros en la segadora o tractor.
- Mantenga a otras personas alejadas de la operación de segado.
- Use la práctica apropiada para parar el equipo antes de bajarse del tractor.
- Permita que se detengan todas las piezas móviles antes de efectuar inspecciones, reparaciones o ajustes al equipo.
- Soporte o coloque bloques firmemente debajo de la segadora antes de trabajar debajo de la segadora o componentes elevados.
- Use la ropa protectora y dispositivos de seguridad personal que le han sido asignados o recomendados por el fabricante del equipo.



Conozca los controles del tractor y segadora

Conozca lo siguiente sobre su tractor y segadora:

- Función, propósito y uso de los controles.
- Velocidades seguras de operación.
- Capacidad para operar en forma segura en pendientes y terreno accidentado.
- Características de frenado y dirección.
- Espacios libres necesarios para la operación del tractor y segadora.
- Cómo detener rápidamente el equipo cuando haya una emergencia.



Use todos los dispositivos de seguridad del equipo disponibles

Para ayudar a mantener su seguridad y la de las personas que lo rodean:

- Asegúrese de que las defensas, blindajes y avisos de seguridad recomendados por el fabricante están instalados en el equipo y en buen estado.
- Mantenga todos los dispositivos protectores en su lugar y abrochados firmemente.
- **NUNCA** debe operar su equipo con los dispositivos de seguridad sin colocar, desconectados o dañados.
- Use el balasto y peso requerido para la estabilidad operativa del equipo.

Inspeccione el equipo de la segadora y tractor

Antes de comenzar su día de trabajo:

- Revise que no haya piezas del tractor y segadora que estén sueltas, rotas, dañadas o que no estén colocadas en su lugar.
- Repare o reemplace estas piezas cuando sea necesario.
- Verifique que los implementos del tractor y segadora sean los apropiados.
- Verifique que sean iguales las rpm de régimen de la toma de fuerza (PTO) a las del tractor y de la segadora.
- Revise el estado de las hojas de la segadora. Afile o reemplace de acuerdo con las recomendaciones del fabricante. Las modificaciones a las hojas como soldadura o endurecimiento de los bordes cortantes con soldadura o enderezado de las hojas dobladas, pueden reducir la resistencia de las hojas y afectar adversamente las propiedades y seguridad de las hojas.
- Verifique que todas las defensas y blindajes estén colocados en su lugar y que todo el equipo esté en buen estado de funcionamiento. Esto incluye la línea de transmisión de la toma de fuerza (PTO), caja de engranajes, defensas y blindajes del implemento que sirven para la protección del operador.
- Verifique que la horqueta de la línea de transmisión y los dispositivos de seguro estén correctamente asegurados.
- Verifique que los sistemas hidráulicos del tractor y segadora no estén dañados ni tengan fugas.
- Revise y lea los avisos de seguridad y las instrucciones de advertencia.
- Explique los avisos de seguridad e instrucciones de advertencia a los usuarios u operadores que no puedan leer.

Inspeccione el área de trabajo

Inspeccione, identifique y evite las condiciones peligrosas en el área de trabajo:

- Terreno accidentado, bajadas escarpadas, zanjas, agujeros, pendientes inclinadas, troncos, agua estancada, suelo de lodo suave, condiciones resbalosas, desechos y objetos extraños.
- Inspeccione el área de segado y elimine o marque todos los objetos extraños y desechos que debe evitar con la segadora.

Analice el área de segado para establecer:

- El mejor y más seguro procedimiento de segado.
- Tipo de material y altura de segado.
- Estado del terreno de operación.
- El uso de un patrón de segado de desplazamiento hacia delante siempre que sea posible.

Verifique la seguridad de las demás personas

Antes de arrancar el equipo:

- Camine alrededor del equipo.
- Verifique que no haya nadie debajo, sobre o cerca del equipo.
- Aleje a todas las personas de estas áreas.
- Haga sonar una alarma.



USE UNA ESTRUCTURA CONTRA VUELCOS (ROPS) y el cinturón de seguridad

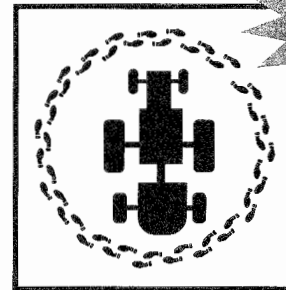

CAMINE ALREDEDOR para inspeccionar

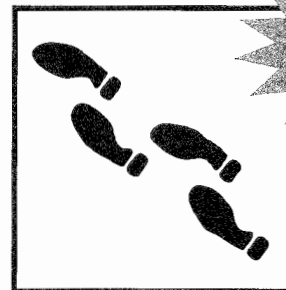

CAMINE ALREDEDOR del lugar de trabajo

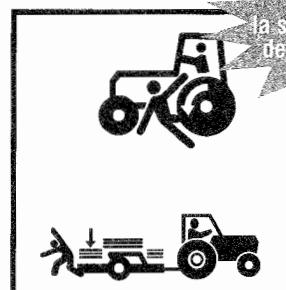

VERIFIQUE la seguridad de las demás personas

Seguridad durante el arranque y prueba

USE
el contacto de
tres puntos



USE UNA
ESTRUCTURA
CONTRA VUELCOS
(ROPS) y el
cinturón de
seguridad



USE la
velocidad
correcta de la
toma de fuerza
(PTO)

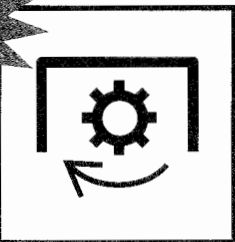

Seguridad durante la subida al tractor

Antes de subir:

- Límpiense los zapatos y las manos.

Durante la subida y la bajada del tractor:

- Use las asas y placas de los escalones.
- Nunca utilice los volantes de dirección o controles como asas.
- Nunca suba ni baje de un tractor en movimiento.

Prueba de seguridad de los controles del tractor y segadora

Antes del arranque:

- Ajuste y abroche el cinturón de seguridad en su tractor equipado con una estructura contra vuelcos (ROPS).
- Verifique que el freno de estacionamiento esté enganchado.
- Verifique que desenganche la toma de fuerza (PTO).
- Verifique que todos los controles estén en la posición de punto muerto (N) o de estacionamiento (P).
- Advierta a las demás personas presentes en el área antes de arrancar el tractor.
- Cumpla con los procedimientos de arranque recomendados por el fabricante del tractor.

Después del arranque:

- Revise que todos los instrumentos, indicadores y luces indicadoras funcionen normalmente.
- Revise que todos los controles, dirección y frenos del tractor funcionen apropiadamente.
- Repare un tractor que no esté funcionando apropiadamente antes de usarlo.
- Suba y baje la segadora cuando la línea de transmisión llegue al fondo o cuando existen problemas de enganche.
- Verifique que su equipo no vibre excesivamente y que no tenga ruidos anormales.
- Use prácticas apropiadas para detener el equipo antes de inspeccionarlo.

Seguridad en el sistema de toma de fuerza y segadora

Tractores con sistemas de doble velocidad (540 ó 1000 rpm) toma de fuerza (PTO) de cambios.

Para evitar las lesiones serias o la muerte por el fallo de piezas causado por la sobrevelocidad de la segadora:

- Asegúrese de colocar el selector de la toma de fuerza (PTO) a la velocidad de régimen de las rpm de la toma de fuerza (PTO).

Tractores con sistemas con toma de fuerza (PTO) impulsados por la transmisión.

Una segadora rotativa tendrá un efecto significativo de volante, que puede continuar impulsando el tractor cuando tiene un sistema de toma de fuerza (PTO) impulsado por la transmisión.

El tractor debe estar equipado y ser operado como se indica a continuación:

- Instale un embrague de sobremarcha.
- Permítase suficiente espacio y tiempo para maniobrar anticipando los virajes, paradas y reducciones de velocidad.

Seguridad durante la operación

Seguridad durante el enganche de la segadora al tractor

Seguridad en el montaje de la segadora con un enganche de tres puntos:

- Haga referencia a los manuales de los fabricantes de la segadoras y el tractor.
- Coloque la palanca selectora del elevador de potencia hidráulica del tractor (eje de balancín) en posición baja para evitar el movimiento inesperado.
- Explique los procedimientos de enganche a los usuarios u operadores que no puedan leer.

Seguridad en el montaje de la segadora con enganche de tipo tiro:

- Haga referencia a los manuales del fabricante de la segadora y tractor.
- Utilice solamente un enganche de barra de tiro.
- No la enganche al eje trasero del tractor ni a los brazos del enganche de tres puntos.
- Ajuste la longitud de la barra de tiro del tractor para la operación de la toma de fuerza (PTO) de 540 ó 1000 rpm.

Comience el uso de la segadora en forma correcta para mayor seguridad

Segue solamente durante el día o cuando exista iluminación artificial adecuada.

Para evitar las lesiones serias o la muerte causadas por objetos despedidos por la segadora o contacto con las hojas:

- Mantenga los blindajes de la cadena, blindajes deflectores flexibles o sólidos, conductos de descarga, colocados en su lugar y en buen estado.
- Mantenga a todas las personas a varios cientos de pies (300 [100 m]) de la operación de segado.
- Nunca dirija hacia ninguna persona la descarga de la segadora.
- Mantenga las manos, pies y otras partes del cuerpo alejadas de las piezas rotativas, hojas y agujeros de descarga.
- No debe operar la segadora en posición de transporte.

Enganche de la transmisión, toma de fuerza (PTO) de la segadora:

- Suba la segadora a la altura máxima de corte.
- Enganche la toma de fuerza (PTO) con rpm bajas del motor.
- Aumente las rpm del motor a la velocidad de régimen de las rpm de la toma de fuerza (PTO).
- Baje la segadora a la altura de corte deseado.
- Deténgase y pare inmediatamente si la segadora golpea una obstrucción.
- Inspeccione y repare cualquier daño que tenga la segadora antes de reiniciar el segado.
- No debe operar la segadora cuando tenga vibración excesiva o ruidos anormales.

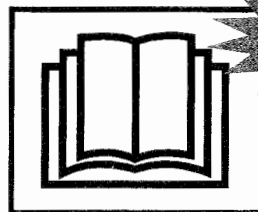

LEA
los manuales

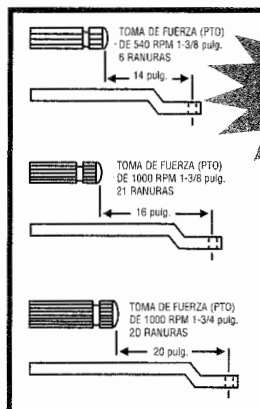

Ajuste
de la barra
de tiro del
TRACTOR

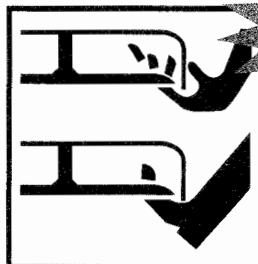

Mantenga la
distancia de
LAS HOJAS
ROTATIVAS

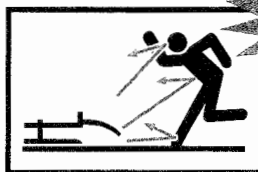

MANTENGA
alejados a los
transeúntes

CUIDE
que no haya
más personas

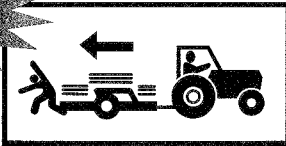

MANTENGA
el rodillo
trasero de la
desgranadora

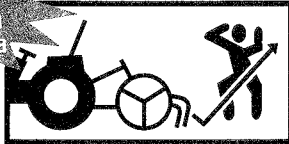

USE las
velocidades
absolutas
apropiadas

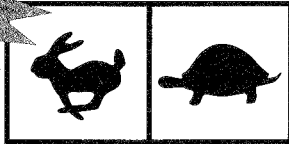

DETENGA
LA HOJA
antes de eliminar
obstrucciones



ESTABLEZCA
QUE el espacio
libre sea adecuado
para la oscilación
de la segadora

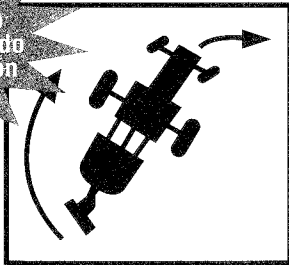

NUNCA
PERMANEZCA
DE PIE sobre
la defensa de
la segadora

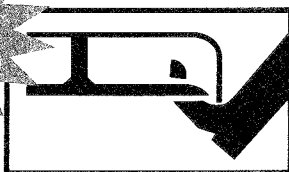

MANTENGA
EL CONDUCTO
colocado en
su lugar

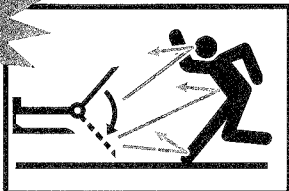

Seguridad durante el segado en marcha atrás

Evite segar en marcha atrás siempre que sea posible.

Haga lo siguiente cuando segue en marcha atrás:

- Verifique que no haya personas atrás de la segadora antes de dar marcha atrás.
- Use extremo cuidado al invertir la dirección del segado.
- Mantenga los blindajes de seguridad delanteros y traseros y los blindajes delanteros de la desgranadora y los rodillos traseros de la segadora rotativa.

Velocidad absoluta de segado

La velocidad absoluta depende de las condiciones del terreno, tipo de pasto, densidad y la altura de corte:

- El alcance normal de la velocidad absoluta es de 2 a 5 mph.
- La velocidad absoluta debe ser menor cuando segue pasto alto y denso.
- La velocidad absoluta puede ser mayor cuando segue pasto de altura mediana, delgado y cuando las condiciones del terreno sean uniformes.
- Use una velocidad absoluta menor cuando segue en pendientes accidentadas o terreno desconocido.

Segado de pasto extremadamente alto

- Puede ser necesario segar dos veces el pasto extremadamente alto.

Primera pasada de segado:

- Haga un corte alto al pasto (10-15 pulgadas [25-38 mm]) para evitar objetos escondidos.

Segunda pasada de segado:

- Retire los desechos y otros objetos.
- Corte el pasto a la altura deseada y a 90 grados de la primera pasada siempre que sea posible.
- Use las prácticas apropiadas de parada del equipo para su seguridad al bajar del tractor.

Vigile los espacios libres del equipo

Las segadoras con enganche de tres puntos y de montaje lateral tienen un arco de viraje mayor que las segadoras de tiro. Permita suficiente espacio libre para virar con seguridad.

Seguridad en el uso de las segadoras montadas en la parte inferior

Cuando segue con una segadora montada en la parte inferior:

- Mantenga el conducto de descarga desmontable colocado en su lugar sobre el agujero de descarga.
- Nunca permanezca de pie sobre la cubierta de una segadora que esté en operación.
- Distribuya el pasto cortado con el conducto de descarga hacia el área ya segada.
- Use las prácticas apropiadas para la parada del equipo antes de eliminar las obstrucciones de la segadora o conducto de descarga.

Riesgos y peligros de obstrucciones elevadas cuando se usan segadoras de ala o pescante

Verifique que no haya obstrucciones elevadas cuando use segadoras con alas levantadas o de tipo pescante, para evitar lesiones graves o la muerte causadas por el contacto con:

- Líneas de transmisión de energía eléctrica.
- Ramas bajas de árboles.
- Otras obstrucciones elevadas.

Seguridad en el uso de las segadoras de ala y de montaje lateral

Cuando utilice segadoras de ala y de montaje lateral:

Las posiciones con el ala levantada reducen la protección del blindaje y aumentan los riesgos de objetos despedidos y de contacto con la hoja.

Para evitar las lesiones serias o la muerte causadas por objetos despedidos o contacto con la hoja por la subida y bajada de las alas durante las operaciones de segado:

- No segue cuando haya transeúntes en el área de segado.
- Asegúrese de que no haya personas cerca cuando suba o baje las alas.
- Mantenga el período de tiempo durante el que está expuesta la hoja rotativa del ala, a un mínimo práctico durante las operaciones de segado con el ala levantada.
- Detenga el segado si entran personas en el área de segado.
- Solamente suba el ala para pasar sobre objetos que se encuentren en el camino de segado o para seguir la inclinación del terreno.
- Desenganche la transmisión del ala durante los períodos prolongados de segado con las alas levantadas.
- Después de pasar sobre un objeto o sobre inclinaciones del terreno, baje el ala levantada, al suelo.
- Permita que todas las hojas de la segadora detengan su rotación antes de levantar las secciones del ala durante otras operaciones.

Seguridad durante el segado de los bordes de las zanjas

Use cuidado extremo cuando sigue los bordes de las zanjas. Vigile para ver si hay derrumbes, áreas erosionadas y obstrucciones para el segado a lo largo del borde de la zanja. El extremo delantero del tractor puede desviarse hacia la zanja al golpear las obstrucciones con las segadoras de montaje lateral o de pescante.

Las operaciones con segadoras con alas levantadas y pescantes pueden reducir la efectividad del blindaje para objetos despedidos de la segadora que sirven para proteger al operador.

Para aumentar la protección del operador de objetos despedidos durante las operaciones en los bordes de las zanjas:

- Use cabinas cerradas con una estructura contra vuelcos (ROPS), cubiertas protectoras especiales y otros blindajes para el operador, cuando efectúe estas operaciones.
- Inspeccione el área de segado y retire o marque todos los objetos extraños y desechos que deben evitarse con la segadora.



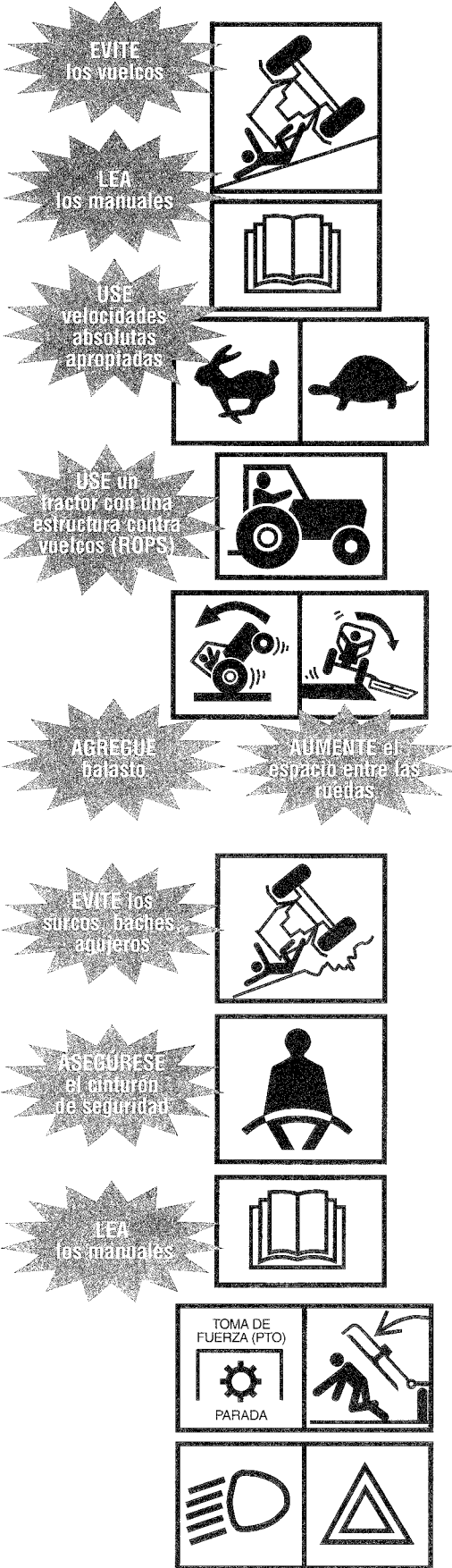

Seguridad durante el segado de terreno accidentado

La estabilidad del tractor y segadora se reduce en las pendientes y terreno accidentado.

Usted puede evitar el vuelco del tractor y segadora y mantener el control de la estabilidad del equipo haciendo lo siguiente:

- Revisando los manuales del operador del tractor y segadora para conocer las prácticas de seguridad de operación en pendientes y terreno accidentado. Explique las prácticas a los usuarios u operadores que no puedan leer.
- Evitando operar en pendientes extremadamente inclinadas.
- Usando cuidado extremo para mantener el control sobre su equipo cuando opere en estas condiciones.
- Aumentando la estabilidad del tractor, agregando pesas a las ruedas y aumentando el espacio entre las mismas, (haga referencia al manual del operador del tractor para conocer las recomendaciones).
- Usando un tractor equipado con una estructura contra vuelcos (ROPS) y cinturón de seguridad para la seguridad del operador durante las operaciones de segado.
- Manteniendo una velocidad absoluta mínima.
- Haciendo virajes anchos y graduales.
- Evitando arranques, paradas y virajes repentinos cuando opere subiendo, bajando o atravesando las pendientes.
- No subiendo del suelo las segadoras montadas atrás o lateralmente ni las alas de segado durante estas operaciones.
- Manteniéndose alerta por si hubiera agujeros, baches, surcos, piedras, troncos u otras obstrucciones que podrían volcar el tractor y segadora.
- Evitando las condiciones de suelo resbaloso que podrían volcar el tractor y segadora.
- Evitando que el tractor y segadora queden atascados al pasar diagonalmente sobre declives y bajadas escarpadas pronunciadas.

Use extremo cuidado para mantener la estabilidad del equipo durante todas las operaciones sobre terreno accidentado y pendientes. Usted tiene la palabra final referente a cualquier pendiente que pueda ser trabajada en forma segura.

Seguridad durante el transporte del equipo en caminos

Si es necesario conducir el equipo sobre los caminos públicos:

- Haga referencia al manual del operador del fabricante del tractor y segadora para conocer las instrucciones.
- Explique las instrucciones a los usuarios u operadores que no puedan leer.
- Verifique las reglamentaciones locales referentes a las marcas, luces, luces intermitentes, etc., requeridas del equipo para el desplazamiento sobre caminos públicos. Se requiere de luces para las segadoras que obstruyen las luces traseras del tractor y/o las luces de advertencia.

Antes del transporte en caminos públicos:

- Desenganche la toma de fuerza (PTO) conectada a la segadora.
- Suba la segadora a la posición de transporte.
- Asegure las alas en la posición de transporte con los seguros en las segadoras de tipo ala y de montaje lateral.
- Enganche la cadena de seguridad entre la segadora de tipo tiro y el tractor.
- Asegúrese de que las luces, luces intermitentes, reflectores y avisos de vehículo de movimiento lento (SMV) están colocados y visibles.
- Revise que el emblema de vehículo de movimiento lento (SMV) sea visible para cualquier vehículo que se acerque desde atrás.

Cuando transporte en caminos públicos:

- Obedezca todas las reglamentaciones locales de tráfico.
- Acérquese a las intersecciones con precaución.
- Cumpla con los avisos de velocidad y de control de tráfico.
- Evite las paradas bruscas y doblar repentinamente.

Seguridad durante el estacionamiento

Estacione el equipo en:

- Áreas designadas o alejadas del tráfico.
- Preferentemente utilice lugares en terreno nivelado.

Lugares de estacionamiento en terreno inclinado:

- Coloque el equipo en posición transversal en las pendientes.
- Aplique los frenos de estacionamiento.
- Baje la segadora al suelo.
- Coloque bloques en las ruedas del tractor.

Antes de estacionar temporalmente y abandonar el equipo incapacitado cerca de áreas con tráfico:

- Retire el equipo de los caminos públicos.
- Coloque las banderas de advertencia.
- Use las luces intermitentes del tractor.

Seguridad durante la parada

Para su seguridad use las prácticas apropiadas para la parada del equipo

Haga referencia al (los) manual(es) del operador del fabricante del tractor y segadora para conocer los procedimientos de parada recomendados. Explique los procedimientos a los usuarios u operadores que no puedan leer.

Haga que los procedimientos apropiados de parada del equipo sean una costumbre importante que se debe practicar. Siga estas prácticas de seguridad antes de bajarse del tractor:

- Desenganche el embrague y transmisión de la toma de fuerza (PTO).
- Para que el motor enfríe gradualmente permita que funcione al ralentí.
- Coloque los controles en estacionamiento (P) o en punto muerto (N).
- Coloque el freno de estacionamiento.
- Baje la segadora al suelo.
- Baje al suelo las alas de las segadoras de tipo ala.
- Apague el motor.
- Espere a que todas las piezas movibles se detengan antes de efectuar inspecciones, ajustes o reparaciones al equipo.
- Descargue la presión hidráulica moviendo los controles hidráulicos varias veces en todas las direcciones.
- Asegure la ignición y extraiga la llave cuando el equipo debe ser inspeccionado, reparado, ajustado o va a permanecer desatendido.
- Asegure las cubiertas contra el vandalismo cuando el equipo permanece desatendido.
- Baje cuidadosamente manteniendo un contacto de tres puntos.

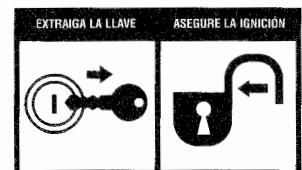
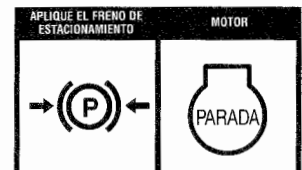
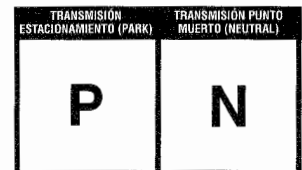
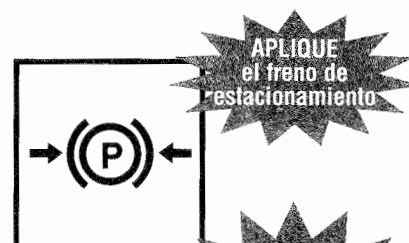

ESPERE que las piezas móviles se detengan antes de bajar

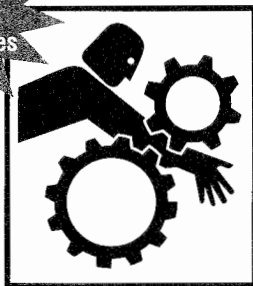

USE el contacto de tres puntos

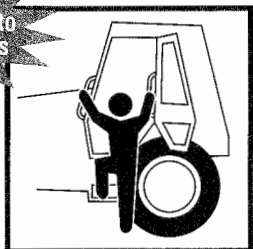

DE MANTENIMIENTO a su equipo

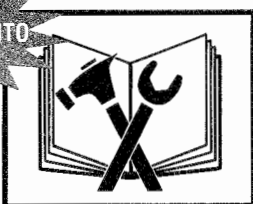

CUMPLA



Seguridad durante la bajada del tractor

Antes de bajar del tractor haga lo siguiente:

- Para su seguridad, use las prácticas apropiadas para la parada del equipo.
- Baje el implemento al suelo, apague el motor y la toma de fuerza (PTO), aplique los frenos, permita que se detengan todas las piezas móviles y extraiga la llave antes de bajar del tractor.
- Nunca baje del equipo cuando esté en movimiento.
- Nunca salte de las máquinas.
- Baje cuidadosamente.
- Verifique que los escalones no estén resbalosos.
- Mantenga los pies y manos alejados de los controles.
- Use las asas para las manos y los escalones para bajar.
- Vea hacia la máquina y use el contacto de 3 puntos (2 manos, 1 pie ó 2 pies, 1 mano).

Seguridad durante el mantenimiento

Seguridad durante el mantenimiento

Para su seguridad haga lo siguiente antes de efectuar procedimientos de mantenimiento, reparación o servicio:

- Cumpla con la práctica apropiada para la parada del equipo.
- Use toda la ropa protectora y equipo de seguridad personal necesarios para efectuar el trabajo en forma segura.
- Haga referencia a sus manuales del fabricante para conocer los procedimientos correctos de mantenimiento, reparación y servicio. Explique los procedimientos a los usuarios y operadores que no puedan leer.

Las fuentes de energía almacenada (eléctrica, mecánica, hidráulica, neumática, química, térmica etc.) deben estar aseguradas, bloqueadas, descargadas, desconectadas, apagadas, aseguradas, neutralizadas, controladas o reducidas a un mínimo práctico, antes de efectuar con seguridad cualquier procedimiento de mantenimiento, reparación o servicio.

Algunas prácticas de seguridad básicas para evitar posibles lesiones causadas por las fuentes que emiten energía:

- Desenganche la toma de fuerza (PTO) antes de apagar el motor.
- Coloque los controles en estacionamiento (P) o punto muerto (N) antes de apagar el motor.
- Aplique el freno de estacionamiento o coloque bloques en las ruedas.
- Permita que todas las piezas movibles se detengan.
- Baje la segadora al suelo.
- En las segadoras de tipo ala, baje las alas al suelo.
- Apague el motor del tractor.
- Asegure la ignición y extraiga la llave.
- Observe y escuche para establecer si hay piezas en movimiento antes de abrir los blindajes.
- Soporte o coloque bloques firmemente debajo de la segadora antes de trabajar debajo de la segadora u otros componentes elevados.
- Soporte, coloque bloques o asegure firmemente las alas de la segadora con los seguros antes de trabajar cerca o debajo de una segadora de tipo ala.
- Descargue la presión del sistema hidráulico moviendo los controles varias veces en todas direcciones.
- Descargue la presión antes de desconectar o desensamblar cualquier sistema presurizado.
- Coloque bloques o descargue la presión del resorte antes de desensamblar cualquier dispositivo a resorte.
- Soporte o bloquee firmemente cualquier componente de la máquina que esté elevado, antes de trabajar en ella.
- Evite las llamas, chispas o fumar cerca de cualquier combustible.

Su seguridad y las piezas del fabricante para la segadora

La mayoría de los fabricantes de segadoras usan sujetadores y piezas especialmente diseñadas para cumplir con los requerimientos de la operación de segado.

Seguridad crítica – piezas relacionadas (pernos de la hoja autoasegurados, hojas, pasadores, blindajes u otros artículos especiales) tienen requerimientos de fuerza, diseño y encaje específicos para el estilo y modelo de la segadora que usted utiliza.

Las modificaciones o piezas para reparación que no son aprobadas por el fabricante de la segadora pueden causar un riesgo significativo por exposición a su seguridad y la de los demás.

PARA EVITAR LAS LESIONES SERIAS O LA MUERTE CAUSADAS POR PIEZAS O MODIFICACIONES NO APROBADAS:

- No sustituya accesorios comunes por los pernos autoasegurados de las hojas u otras piezas especiales.
- No sustituya las hojas, pasadores, blindajes u otras piezas relacionadas con la seguridad crítica.
- No use pernos de grado 5 u 8 para reemplazar los pernos de resistencia limitada grado 2.

CUMPLA LA PRÁCTICA SEGURA DE SIEMPRE VERIFICAR EL FUNCIONAMIENTO CORRECTO DE TODOS LOS AJUSTES, REPARACIONES O SERVICIO DE LA SEGADORA.

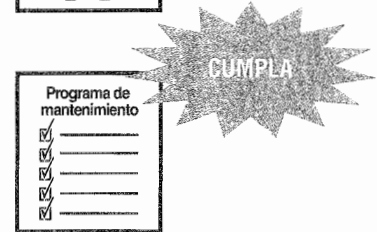

Palabra final

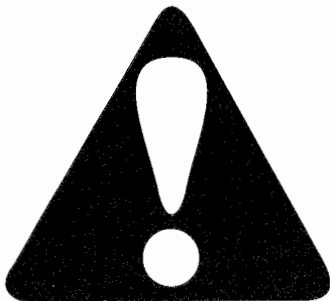

Usted ha terminado de leer el manual de seguridad de la segadora. Es imposible que este manual incluya toda situación peligrosa potencial que usted pueda encontrar. Sin embargo, su conocimiento de estas precauciones de seguridad y su cumplimiento de las reglas básicas de seguridad le ayudarán a crear buen juicio para todas las situaciones. Nuestro objetivo es ayudarle a desarrollar buenos hábitos de seguridad y hacerlo un mejor operador de segadora. El manual de seguridad de la segadora, precauciones de seguridad y reglas básicas de seguridad deben explicarse a los usuarios u operadores que no puedan leer.

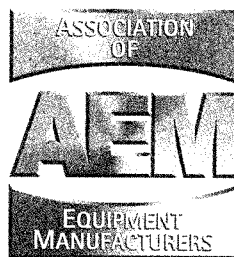

111 E. Wisconsin Avenue • Milwaukee, Wisconsin 53202 U.S.A.
www.aem.org

Para obtener información de reproducciones adicionales y
otros manuales de seguridad, llame al 800-369-2310

INTRODUCTION SECTION

Introduction Section 2-1

INTRODUCTION

This Flail Mower is designed with care and built with quality materials by skilled workers. Proper assembly, maintenance, and operating practices, as described in this manual, will help the owner/operator get years of satisfactory service from the machine.

The purpose of this manual is to familiarize, and instruct. The Assembly Section instructs the owner/operator in the correct assembly of the Mower using standard and optional equipment. The Parts Listing section is designed to familiarize the owner/operator with replaceable parts on the Mower. This section provides exploded assembly drawings of each mower component illustrating each piece and the corresponding part number.

Careful use and timely service saves extensive repairs and costly downtime losses. The Operation and Maintenance Sections of the manual train the owner/operator how to work the Mower correctly and attend to appropriate maintenance. The Trouble Shooting Guide helps diagnose difficulties with mower and offers solution to the problems.

Safety is of primary importance to the owner/operator and to the manufacturer. The first section of this manual includes a list of Safety Messages, that, if followed, will help protect the operator and bystanders from injury or death. Many of the Safety Messages will be repeated throughout the manual. The owner/operator/dealer should know these Safety Messages before assembly and be aware of the hazards of operating this mower during assembly, use, and maintenance. The Safety Alert Symbol combined with a Signal Word, as seen below, is intended to warn the owner/operator of impending hazards and the degree of possible injury faced when operating this machine.



Indicates an imminently hazardous situation that, if not avoided, WILL result in DEATH OR VERY SERIOUS INJURY.



Indicates an imminently hazardous situation that, if not avoided, COULD result in DEATH OR SERIOUS INJURY.



Indicates an imminently hazardous situation that, if not avoided, MAY result in MINOR INJURY.



Identifies special instructions or procedures that, if not strictly observed, could result in damage to, or destruction of the machine, attachments or the environment.

INTRODUCTION

FC-FL-0010

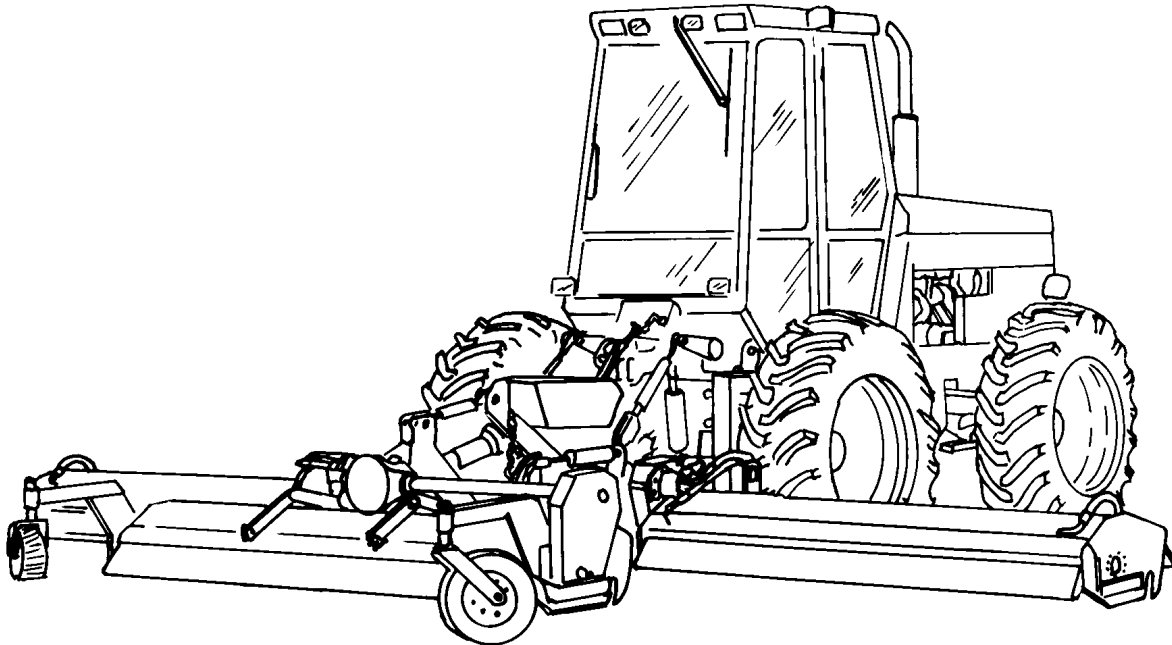

INTRODUCTION

The Versa Pro Flail Mower is designed for medium-duty cutting such as lawn maintenance plus small weed and grass control. With a reasonable amount of preventive maintenance, your mower will provide years of dependable service.

▲ DANGER

For Non-Agricultural use, OSHA, ASAE, SAE, and ANSI standards require the use of Chain Guards, Deflectors, or Solid Skirts at all times. The Mower manufacturer strongly recommends the use of Chain Guards, Deflectors, or Solid Skirts for Agricultural purposes as well to reduce the risk of property damage, serious bodily injury, or even death from objects thrown out by or from contact with the Cutting Blades.

Mower Orientation: Front and rear, and left and right are determined by the normal direction of travel (the same as your automobile).

▲ WARNING

At least 20% of the tractor's total weight must be on the front tires with the Mower lifted to provide adequate traction for safe steering under good conditions. Slow down on hills, rough terrain, and curves.

Front and rear, and left and right are determined by the normal direction of travel (the same as on your automobile).

INTRODUCTION

Attention Owner/Operator

BEFORE OPERATING THIS MACHINE:

1. Carefully read the Operator's Manual, completely understand the Safety Messages and instructions, and know how to operate correctly both the Mower and Power Unit.
2. Fill out the Warranty Card in full. Be sure to answer all questions, including the Serial Number of the Mower. Mail promptly using the return envelope included with the Operator's Manual.

NOTE: Warranties are honored only if completed "Owner Registration and Warranty" forms are received by Alamo Group within thirty days of delivery of the mower.

3. Record the Mower Model and Serial Numbers on the Warranty page at the end of the Operator's Manual. Keep this as part of the permanent maintenance file for the Mower.

IMPORTANT

For your safety and to guarantee optimum product reliability, always use Genuine ALAMO INDUSTRIAL replacement parts. The use of inferior "will-fit" parts will void Warranty of your ALAMO INDUSTRIAL implement and may cause premature or catastrophic failure which can result in serious injury or death. If you have any questions concerning the repair parts you are using, contact ALAMO INDUSTRIAL, 1502 E. Walnut Seguin, TX 78155 (830) 372-3551.

 **ALAMO**
INDUSTRIAL 02925100

ASSEMBLY SECTION

Assembly Section 3-1

ASSEMBLY

Important

The hydraulic system must be kept "SURGICALLY CLEAN" to ensure proper operation and long life of the pumps, motors, and valves. All components have protective caps over openings connected to internal spaces to prevent contamination. It is important that care be taken during unpacking, assembly, and other contaminants which will damage parts.

DO NOT start the tractor unless the hydraulic system is filled with hydraulic oil. Running without oil will damage the pumps.

Check the oil level in the reservoir before start-up.

Care should be taken when filling the reservoir to prevent contamination of the hydraulic system. Always use new hydraulic fluid when filling the system. USE ONLY UNIVERSAL TRACTOR HYDRAULIC OIL IN THE HYDRAULIC SYSTEM.

Reference to the left or right side is determined while standing in the rear & facing in the direction of travel.

TRACTOR PREPARATION

1. Remove the Anti-Sway Bars from tractor and Lower Links.
2. Remove the Pins that attach the Lower Links to the Down Links and the Tractor Lugs. Remove the Lower Links. Insert the Pins back into the Down Links and the Tractor Lugs. These Pins will be used when attaching the V-Pro to the tractor.
3. Remove the complete Draw Bar and carrier from the Tractor.

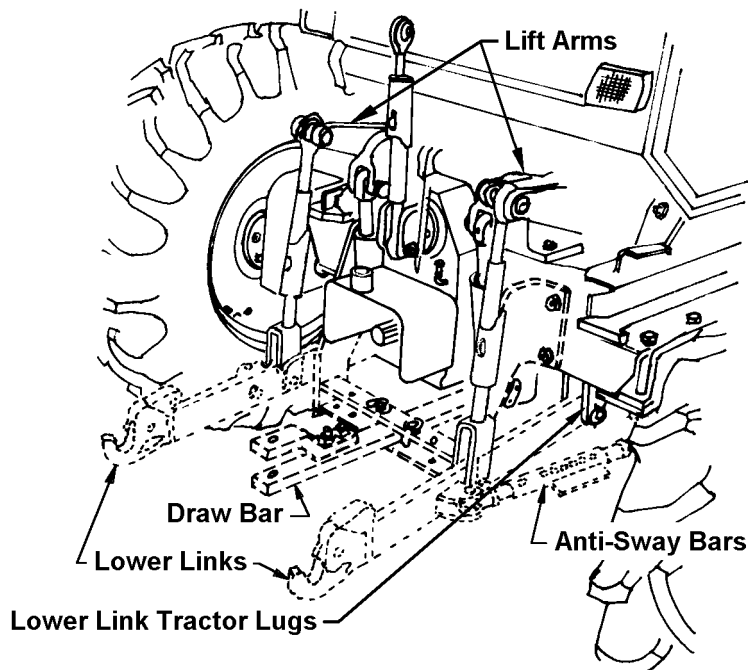

ASM-FL-0097

ASSEMBLY

MAINFRAME TO ATTACHMENT FRAME ASSEMBLY

Place Mainframe on a level surface. Raise Mainframe with a forklift or hoist and attach the Jack stands. Raise Jack stands until the Mainframe is raised to approximately 18". Align the Attachment Frame (3) lugs with Mainframe, install the Pins (4) and retain with 1/2 x 1-3/4 bolts (5), flatwashers (6) and locknuts (7). Install the Axle Mount Bars (8) and retain with Pins (9) and Cotter Pins (10).

NOTE: It will be necessary to lower tank assembly in order to install pin (4).

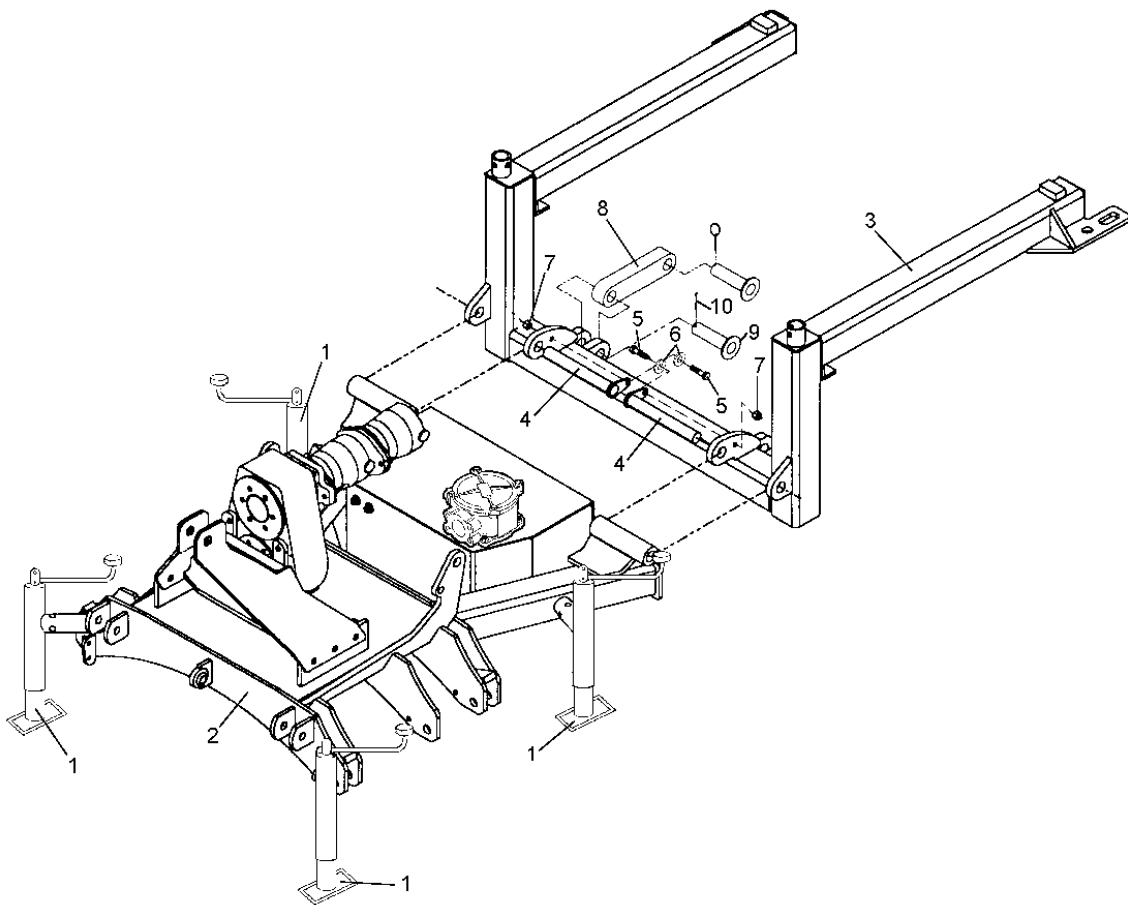

ASM-FL-0098

ASSEMBLY

TRACTOR TO ATTACHMENT FRAME ASSEMBLY

Raise the Attachment Frame Arms(1) to a level height. Drive Tractor into Attachment Frame and align with the Tractor Attachment Frame Mounts (2). Retain with bolt (3) and locknut (4). **ASM-FL-0099**. Attach the Axle Mount Bars (5) to the Tractor lugs with Pins (6) and Lynch Pins (7). **ASM-FL-0100**. Attach the Down Links (8) to the Mainframe with Pins (9) and Lynch Pins (10). **ASM-FL-0101**. **NOTE:** Adjust down links to 28" pin center.

ASSEMBLY

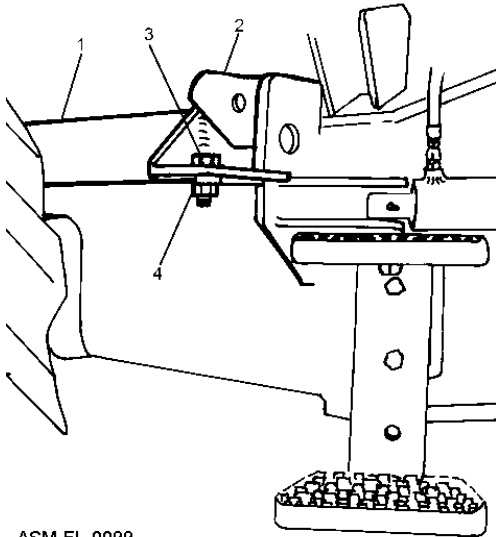

ASM-FL-0099

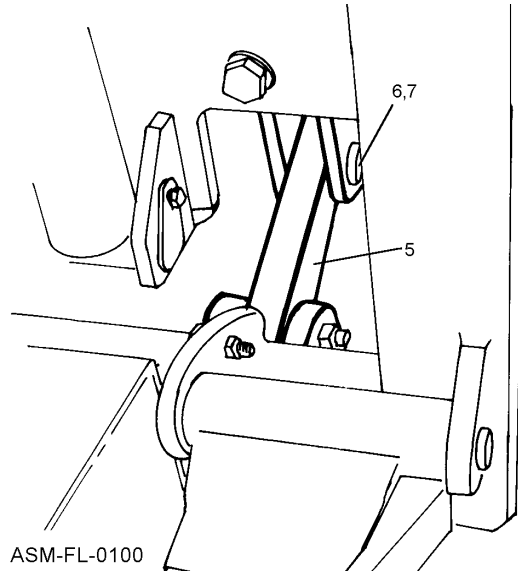

ASM-FL-0100

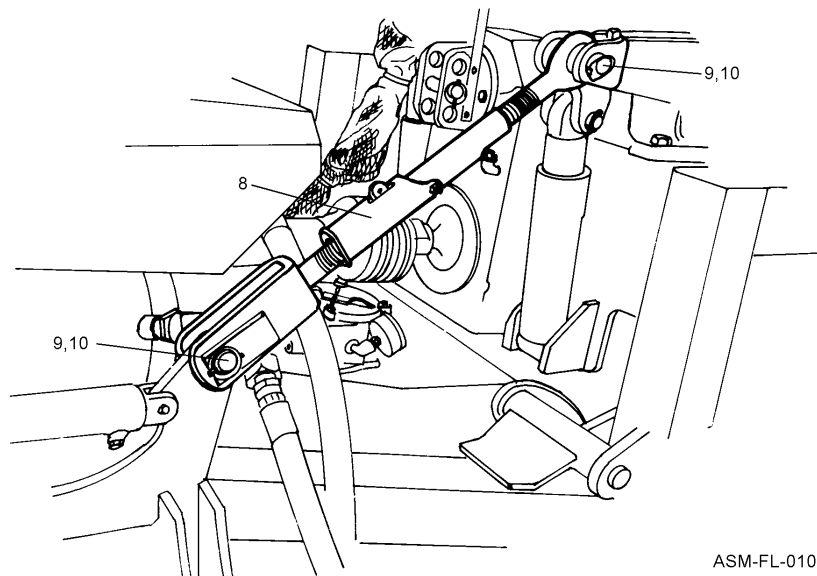

ASM-FL-0101

ASSEMBLY

DRIVELINE ATTACHMENT

Pull slide collar back and attach one end to the Tractor PTO. Move yoke back and forth until locking collar "clicks" forward and locks the yoke in place. Do the same to the other end of the Driveline on the Speed Increaser shaft.

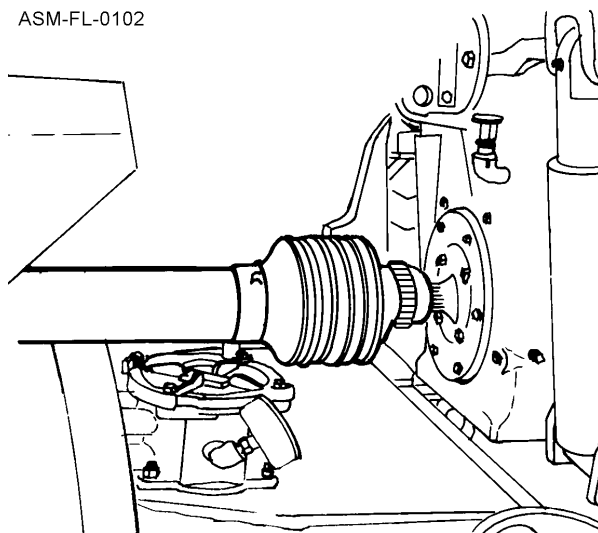

CENTER & WING MOWER ASSEMBLY

Tip cutterhousing back and place a block under roller to safely support unit. Remove shipping skids and drive pulley side belt guard fender. If necessary, install knives, as shown, one row at a time. See rotation below.

FOR FORWARD ROTATION: On the right wing and center unit, all knife pins must be installed with their heads facing away from the cuttershaft pulley. On the left wing, the heads of the knife pins must face the cuttershaft pulley.

FOR REVERSE ROTATION: On the right wing and center unit, all knife pins must be installed with their heads facing toward the cuttershaft pulley. On the left wing, the heads of the knife pins must face away from the cuttershaft pulley.

This will locate cotter pins where knives cannot reach them when flexing backward. The housing side sheet has a hole in it which allows knife pins to be inserted into end lugs from outside the cutterhousing. After the cotter pin is installed, bend extended prong at a 45 Degree angle with prong parallel to lug.

With the cutterhousing tipped up, attach housing shoes/wear plate. Carriage bolt attaches to front mounting hole; plow bolts attach to middle and rear holes.

ASSEMBLY

ASSEMBLY

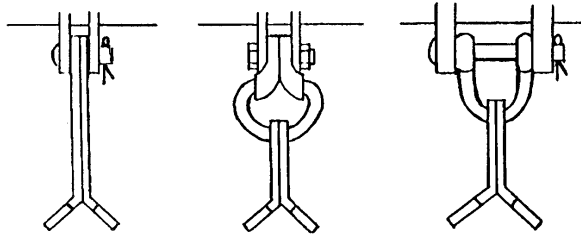

ASM-FL-0047

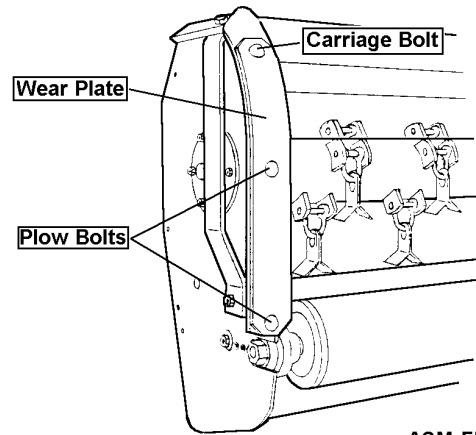

ASM-FL-0058

WING MOWER ATTACHMENT

To attach wing mower to mainframe. Align tilt link (1) with actuator (2) and retain with pin (3). Proceed to lift frame (4) and align with lug on mainframe (5), retain with pin (6) and with pin (7). Secure all pins with 1/2" x 1 1/2" bolt and 1/2" nut. **ASM-FL-0103**. Pin (3) will be secured with bolt that also secures pin for cylinder.

LIFT FRAME TO MOWER

Align toplink (1) to mower lugs (8), retain with pin (9) and lock with cotter pins (10). Align lift frame (4) with lugs at bottom of mower, retain with pivot pin (11) and lock with nut (12). **ASM-FL-0103**.

NOTE: Use a thread locking material to secure nut (12) to pivot pin.

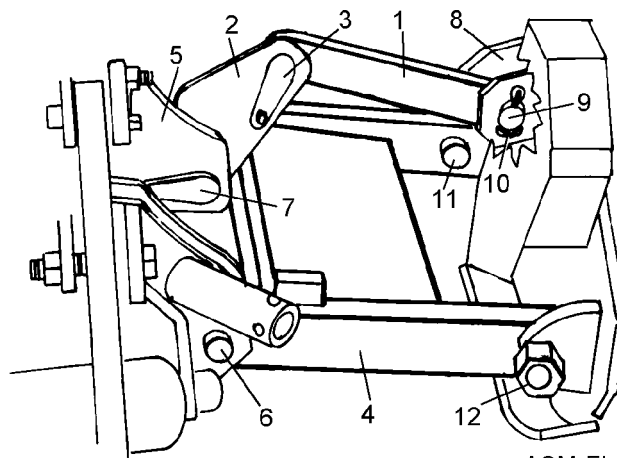

ASM-FL-0103

ASSEMBLY

ELECTRICAL CONNECTION AT TRACTOR

Battery cable must be disconnected to prevent any electrical shock. Unscrew bottom screws from panel with regular tip screwdriver (**ASM-FL-0104**). Pull down on panel from bottom, and top should pop out. Place a small block of wood inside of console against side wall to protect wiring when drilling holes for switch. Both sides of console should be drilled for switch to be mounted (**ASM-FL-0104**). Once the switches are installed, connect switch connectors from harness to the top spade terminals of switch. Connect power wires to ignition switch at accessory terminal (**ASM-FL-0105**). Connect ground wire to ground (**ASM-FL-0105**). Wire harness should then be routed through console, then through hole underneath seat at pivot point. Wire harness should then exit at hydraulic hoses connection, at front of tractor. Connect wire harness from tractor to the wire harness from mower. Refer to electrical schematic (**ASM-FL-0106**) for additional help.

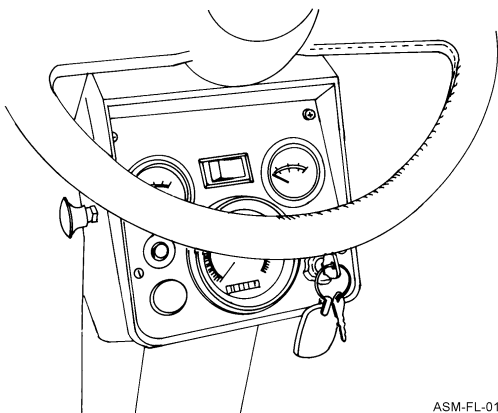

ASM-FL-0104

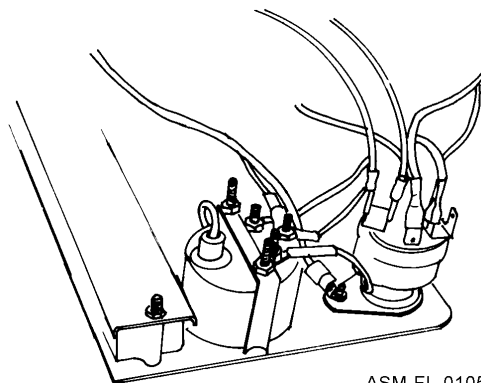

ASM-FL-0105

ELECTRICAL CONNECTION AT MOWER

Connect terminals on harness to corresponding terminals on safety switch. Continue harness routing with hoses and attach connector at end of harness to solenoid coil on motor. Secure with screw and gasket provided with harness. **ASM-FL-0106**. Refer to electrical schematic (**ASM-FL-0107**) for additional help.

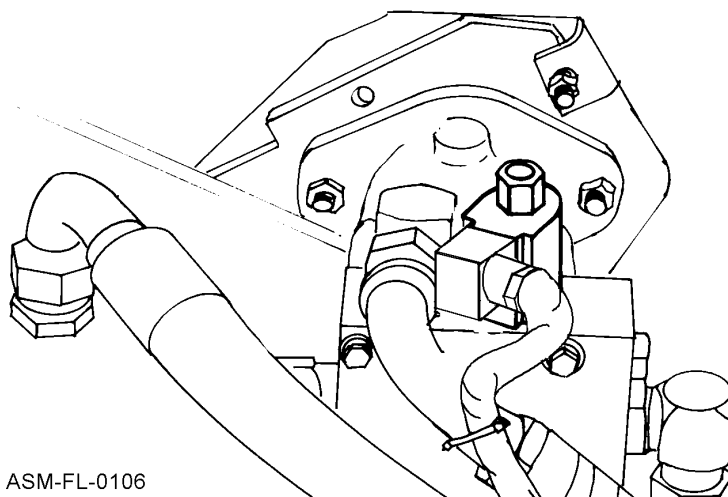

ASM-FL-0106

ASSEMBLY

ASSEMBLY

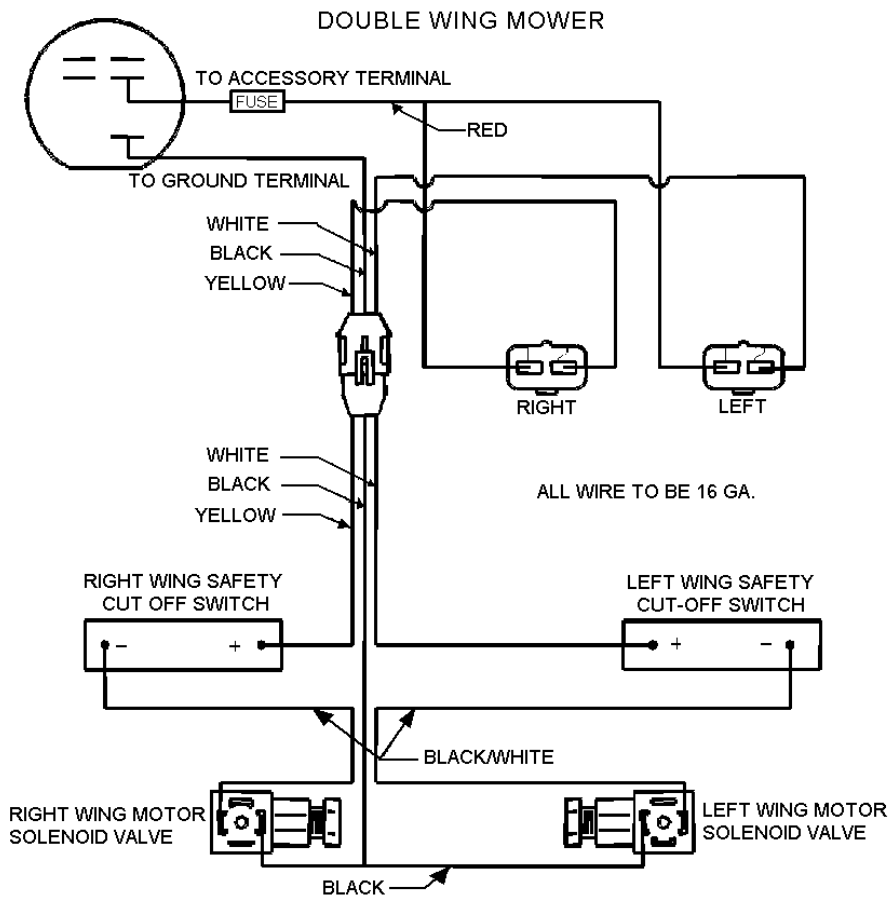

ASM-FL-0107

CENTER MOWER ASSEMBLY

Attach the right and left Overarms (1) to the cutterhousing. Secure with 5/8 x 1-3/4 bolts (2) and locknuts (3). Attach the A-Frame Weldment (4) to the Overarms with bolts (2) and locknuts (3). **ASM-FL-0108.**

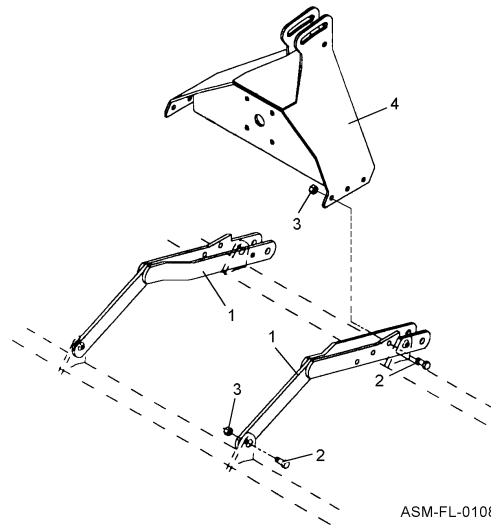

ASM-FL-0108

ASSEMBLY

CENTER MOWER ASSEMBLY

1. Attach outboard bearing plate to cutterhousing.

FORWARD ROTATION (Bearing plate mounts on left side of cutterhousing.)

a. Secure with 3/8 NC x 7/8 Bolt and nut at front mounting hole. Torque to 35 ft.-lbs. (Typ.)

b. Secure with 3/8 NC x 2-1/4 Bolt, nut, lockwasher, and second nut at rear mounting hole. The Bolt is used as an anchor for the idler arm spring.

REVERSE ROTATION (Bearing plate mounts on right side of cutterhousing)

a. Secure with 3/8 NC x 2-1/4 Bolt, nut and second nut at front mounting hole. The Bolt is used as an anchor for the idler arm spring.

b. Secure with 3/8 NC x 7/8 Bolt and nut at rear mounting hole.

2. Install gearbox & extension shaft assembly and PTO shield mounting bracket

a. Remove existing nuts and lockwasher from bearing housing.

NOTE: On forward rotation units, remove only the lower two fasteners.

b. Slide bearing housing Bolt into proper holes in outboard bearing plate.

c. Attach gearbox and mounting bracket to gearbox mounting frame. Secure with 5/8 NC x 1-1/4 Bolt (upper gearbox feet), and 5/8 NC x 1-1/2 Bolt (lower gearbox feet) and Lockwashers. Torque to 170 ft.-lbs. (Typ.)

d. Secure bearing housing to bearing plate with previously removed fasteners.

IMPORTANT: If extension shaft does not line-up with Gearbox, it may be necessary to shim gearbox mounting lugs. To accomplish this, insert one gearbox retaining bolt (Figure 15) through the mount plate and into the gearbox housing. Do not tighten this bolt (it should have at least 1/4" free threads to move in and out). Assemble the gearbox, shaft, shaft extension tube and the bearing to the bearing retainer plate mounted on the side sheet. Tighten all fasteners except the one bolt in the gearbox mounting plate. Check the distance between the gearbox mounting lugs and the mount plate. If required, insert shims from shim kit (P/N 000552) between gearbox mounting lugs and mounting plate to insure the gearbox pulls up evenly on the mounting plate.

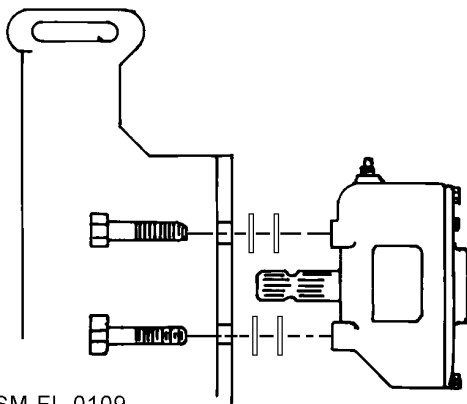

ASM-FL-0109

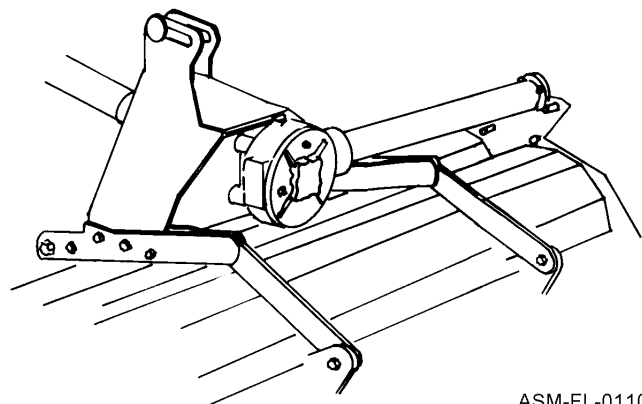

ASM-FL-0110

ASSEMBLY

ASSEMBLY

CENTER MOWER ASSEMBLY

Install idler arm assembly to bearing plate. Do not secure at this time. **ASM-FL-0052.**

1. Remove fasteners and shaft protector from end of drive shaft. Lightly grease shaft. Install key and drive shaft pulley. Do not secure at this time. **ASM-FL-0052.**
2. Align all three pulleys. Use spacers and shims provided to achieve alignment, then secure idler arm assembly with cotter pin. Secure drive shaft pulley with fasteners removed in Step 1, above.
3. Install drive belt. **ASM-FL-0053_A.**
4. Attach spring. One end is inserted in idler arm spring arm hole; the other end is attached to the long outboard bearing plate bolt.

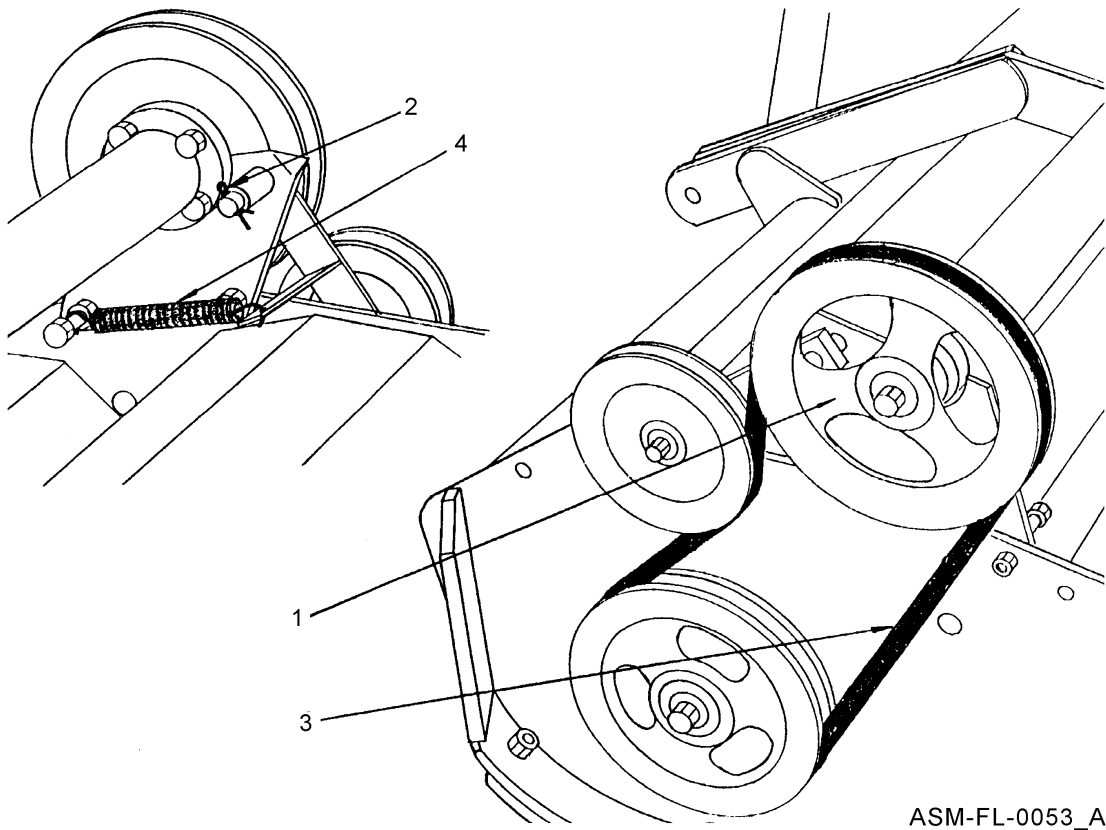
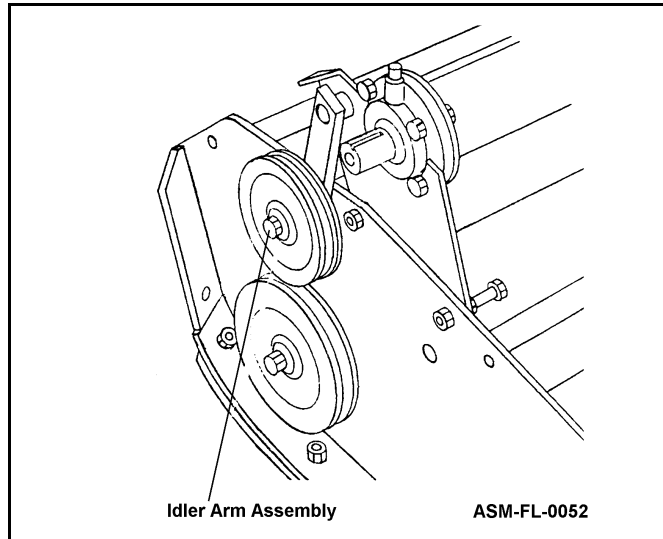

ASSEMBLY

INSTALLATION OF CENTER MOWER

ASM-FL-0111

1. To properly attach center mower to mainframe, align lower links (1) to overarms (2) and anti-sway bar (3). Attach with 7/8" x 5" bolt and 7/8" locknut (4).
2. Align toplink (5) with top of A-frame (6) on center mower and retain with pin (7), washers (8), and cotter pins. Attach the other end of the toplink to the mainframe. Install 1" x 4" bolt through safety chain and retain with 1" locknut.
3. Continue with driveline by aligning slipclutch and gearbox shaft and slide slipclutch in and tighten bolt. On the other end of driveline pull slide collar back, slip into speed increaser shaft and release slide collar. Move driveline in and out to insure driveline is secure.
4. Level front unit by adjusting top link. Be sure skid shoes are level with ground.

NOTE: Front Caster Wheels should be set about 2-4 inches above ground when mower is level.

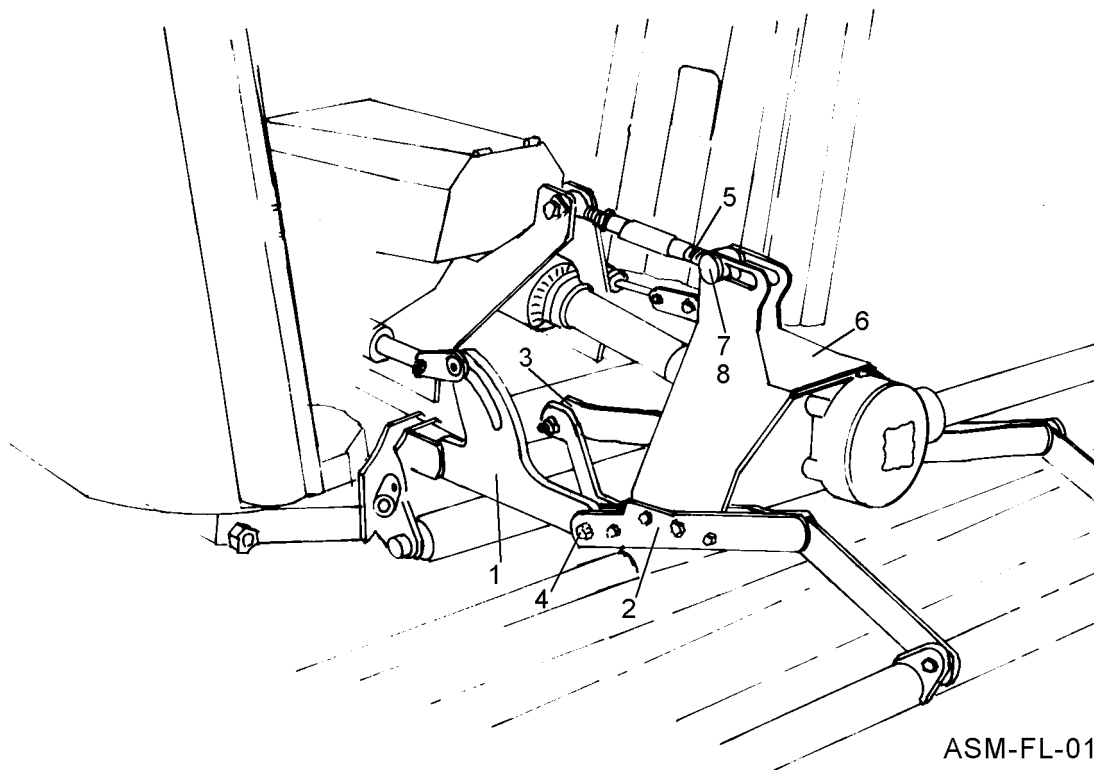

ASM-FL-0111

ASSEMBLY

ASSEMBLY

HYDRAULIC CONNECTIONS

WARNING

Refer to the Tractor Manual when connecting hydraulic hoses to the tractor hydraulic system. Numerous precautions should be taken due to the possibility of a pressure buildup within the hydraulic circuit. Relieve the pressure before opening or entering the circuit. **FLUID ESCAPING UNDER PRESSURE CAN PENETRATE THE SKIN CAUSING SERIOUS INJURY.** Ensure that hose fittings are secure before pressurizing the hydraulic systems.

Important

Once drivelines are installed, **DO NOT** start the tractor (which will turn the pumps) unless both power circuits are filled with the specified hydraulic fluid. Running pumps without oil will cause non-warrantable damage.

It is important that pipe thread sealant be used only on solid connections of pipe thread; never on connections between swivel fittings and solid male pipe threads or on straight thread "O" ring fittings. Use the pipe thread sealant supplied. Do not substitute with some other type of sealant, i.e., teflon tape, paint, shellac, etc.

Hoses supplied have two types of fittings; solid or swivel. Some hoses have solid fittings on both ends; others have a solid fitting and a swivel fitting. Hoses with two solid fittings will fit into either a outer solid thread, or a swivel adapter union. When installing either type hose, solid fittings must be installed first, then install the swivel end of the hose.

The VERSA PRO hydraulic system incorporates three basic types of hydraulic fittings:

- Standard pipe (NPT or NPTF) thread fittings. This type requires a small amount of evenly-applied sealant.
- Swivel fittings. This type does not require any sealant on the swivel end because it seals against an internal flare.
- "O" Ring fittings. This type does not require any sealant on the "O" Ring end of the fitting.

It is extremely important to avoid getting pipe thread sealant inside the fittings or hoses. **KEEP THE INTERIOR OF ALL HYDRAULIC COMPONENTS SURGICALLY CLEAN.** Inspect the inside diameter of each hose before assembly. Ensure that no obstruction is present. Dirt, sand, dust, etc., are abrasive and once in the system can cause immediate or early failure.

NOTE: Do not strap hoses together until all hoses and wiring are connected. Hoses and wiring should be routed so they do not lay on moving parts, too close to sharp edges, or near excessive heat.



ASSEMBLY

HOSE CONNECTION AT TRACTOR

1. To properly connect hydraulic hoses to tractor, connect right wing hose P/N 02839000 (1), and left wing hose P/N 02839000 (2). **ASM-FL-0112.**
2. Connect center lift hose P/N 02964451 (3) to connection at center of tractor. **ASM-FL-0112.** This should be the remote valve with "Float" position. Always operate front mower in float detent position.

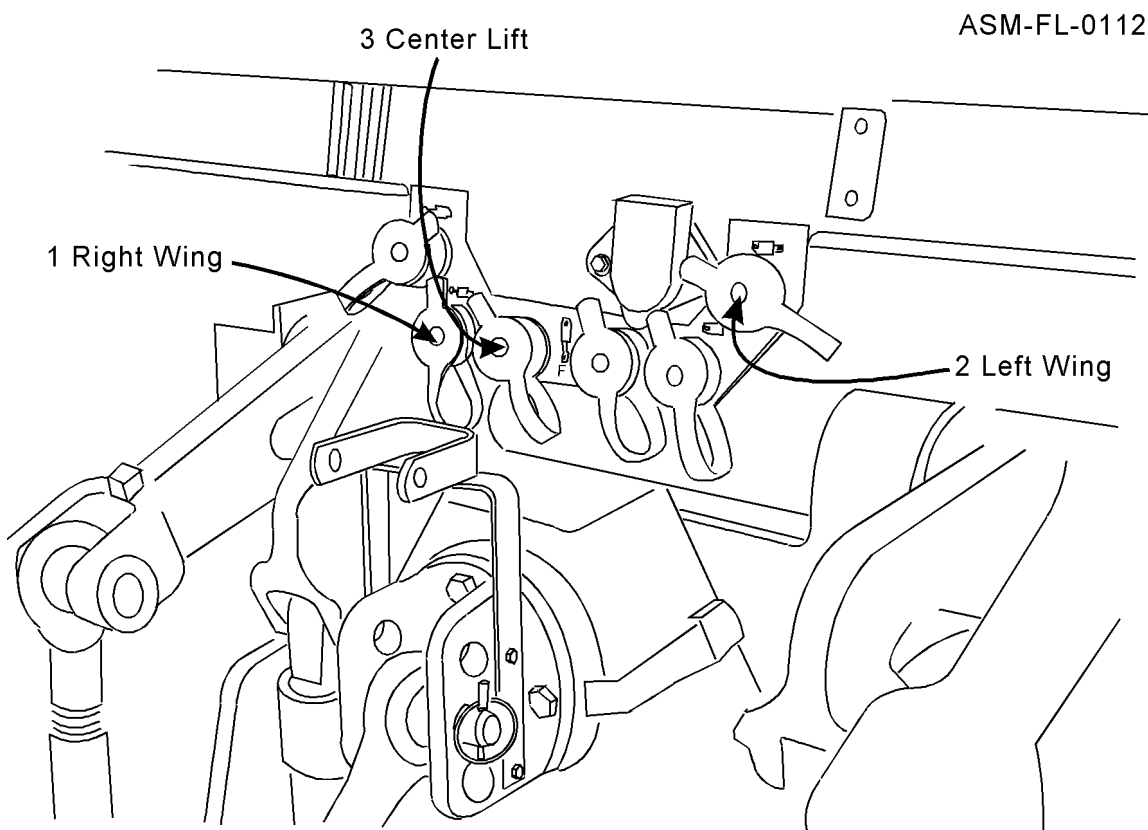

ASSEMBLY

ASSEMBLY

HYDRAULIC CONNECTIONS TO CYLINDER

Connect the Hoses P/N 02965364 and P/N 02961321 from Tee to Center Lift Hydraulic Cylinders at rod end.

HYDRAULIC CONNECTIONS TO FILTER

Connect return hose P/N 002479 from right wing mower to elbow at filter (identified as "A"). Left wing mower will use hose P/N 002477 and will be connected to Tee (identified as "B"). **ASM-FL-0113**

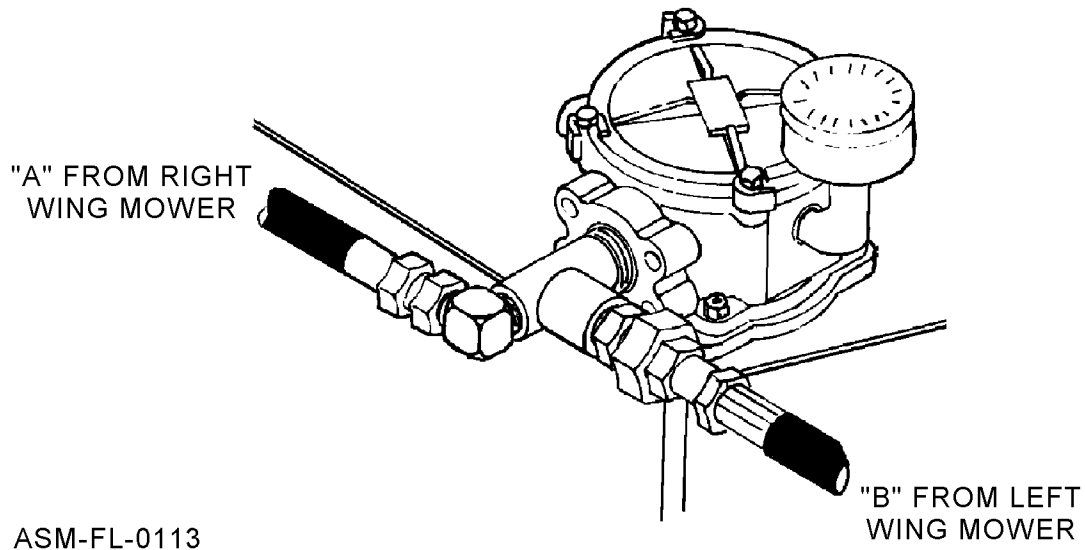

HYDRAULIC CONNECTIONS TO PUMP

Connect right wing hydraulic motor to pump using hose P/N 002480 (identified by "C"). Left wing motor will use hose P/N 002478 (identified as "D"). **ASM-FL-0114.**

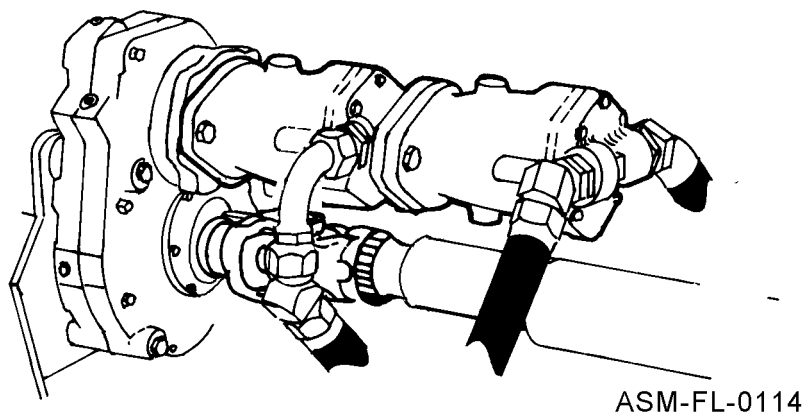

ASSEMBLY

HYDRAULIC CONNECTION MOTORS

Left Wing Hydraulic Motor

To connect hydraulic hoses to left side mower, use hose P/N 002477 (identified as "B"). This hose comes from filter at tank. Hose P/N 002478 from pump to motor (identified as "D"). **ASM-FL-0115.**

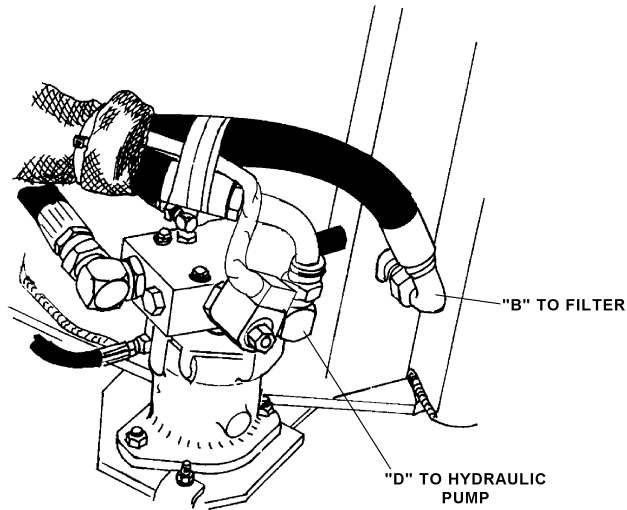

ASM-FL-0115

Right Wing Hydraulic Motor

To connect hydraulic hoses to right side mower, use hose P/N 002480 (identified as "C"). ASM-FL-0116. This hose comes from pump. Hose P/N 002479 filter at tank (identified as "A").

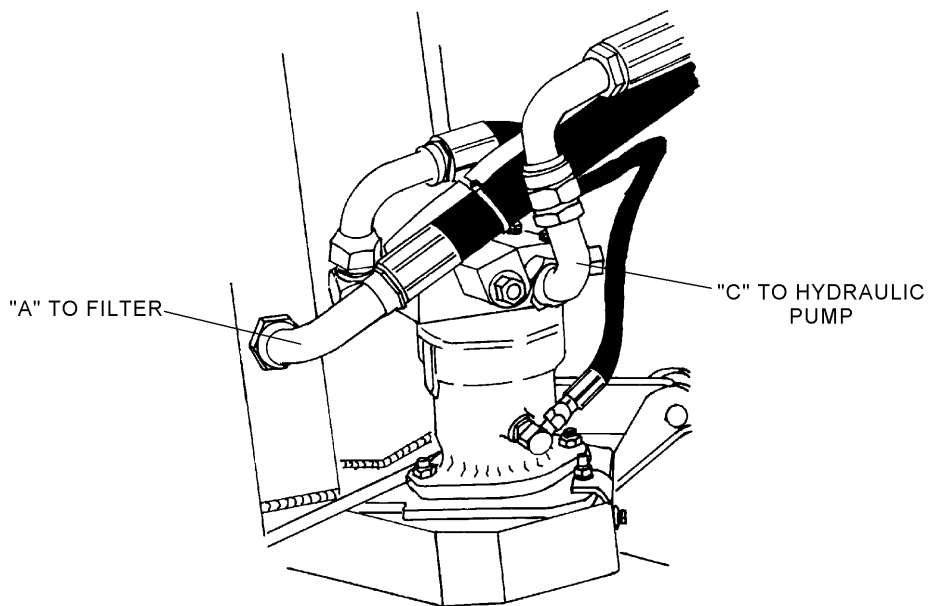

ASM-FL-0116

ASSEMBLY

HYDRAULIC

Filter buggies or carts are commercially available for hydraulic system charging. These consist of a high-efficiency, high-capacity filter, a pump, a drive motor, and hoses for supplying the machine's hydraulic system.

After the first 10 hours of operation, replace the hydraulic filter with a new one. An extra Filter Element is provided for you. Refer to the Operation and Maintenance Section for instruction.

After the VERSA PRO mower is completely assembled to the tractor and with the wings on the ground, fill the mower hydraulic tank above the oil level sight gauge approximately 1" below the top of the tank.

With mower ON/OFF switches in "OFF" position, start engine and engage PTO for about 30 to 45 seconds to allow oil to fill pumps and motors. Check the oil level in the sight gauge. If no oil is seen, add oil to bring the level up to the sight gauge.

NOTE: Do not fill the tank with oil above the level of the sight gauge. Overfilling the tank with oil after the initial filling may result in oil being discharged through the air filter on top of the hydraulic tank. Start the tractor and PTO and run it for 2 minutes and then turn it off. Again, check the oil level in the sight gauge. If the oil level is in the sight gauge, the unit is ready to run. If no oil is seen, add oil to bring the level up to the sight gauge.



Remove all foreign objects and stand clear of cutter units. **DO NOT GET NEAR ROTATING KNIVES!**

NOTE: On tractor hydraulic powered circuit only, make certain that there is full flow from tractor hydraulic system to control valve. Refer to tractor manual.

After hydraulic system is fully charged and functioning properly, switch cutter units on, then speed engine up to 540 RPM PTO speed. Maintain this speed for about 5 minutes. Check complete VERSA PRO, look for any leaks, loose connections, or anything that could cause premature wear or failure.

FINAL CHECK

Run VERSA PRO for about 1/2 hour at full speed. Check for leaks and vibrations. Frequently check oil temperature. Make certain it does not exceed 180 degrees.



DO NOT leave until unattended, and COMPLY WITH ALL WARNING DECALS.

If unit starts to make unusual noise, stop unit and check oil level. Also check for frothy oil which would indicate a leak on suction side of system.

OPERATION SECTION

Operation Section 4-1

OPERATION

ALAMO INDUSTRIAL VERSA PRO FLAIL OPERATION INSTRUCTIONS

Alamo Industrial Versa Pro flail mowers are manufactured with quality material by skilled workers. These mowers are designed to cut grass, weeds, small brush, and other vegetative material up to 2" in diameter. The mower is equipped with protective deflectors and chain guards to prevent objects being thrown from the mower by the blades, however, no shielding is 100% effective. All shields, guards, deflectors, and chains equipped on the unit must be maintained on the mower in good operational condition.

It is the operator's responsibility to be knowledgeable of all potential operating hazards and to take every reasonable precaution to ensure oneself, others, animals, and property are not injured or damaged by the mower, tractor, or a thrown object. Do not operate the mower if passersby, pets, livestock, or property are within 100 yards of the unit.

This section of the Operator's Manual is designed to familiarize, instruct, and educate safe and proper mower use to the operator. Pictures contained in this section are intended to be used as a visual aid to assist in explaining the operation of a Versa Pro flail mower and are not specific to any model. Some pictures may show shields removed for purposes of clarity. NEVER OPERATE this implement without all shields in place and in operational condition. The operator must be familiar with mower and tractor operation and all associated safety practices before operating the mower and tractor. Proper operation of the mower, as detailed in this manual, will help ensure years of safe and satisfactory use of the mower.

IMPORTANT: To avoid mower damage, retorque all bolts after the first 10 hours of operation. Refer to the Torque Chart at the end of the Maintenance Section to ensure bolts are properly tightened.

READ AND UNDERSTAND THE ENTIRE OPERATING INSTRUCTIONS AND SAFETY SECTION OF THIS MANUAL AND THE TRACTOR MANUAL BEFORE ATTEMPTING TO USE THE TRACTOR AND IMPLEMENT. If you do not understand any of the instructions, contact your nearest authorized dealer for a full explanation. Pay close attention to all safety signs and safety messages contained in this manual and those affixed to the implement and tractor. OPS-U- 0001

READ, UNDERSTAND, and FOLLOW the following Safety Messages. Serious injury or death may occur unless care is taken to follow the warnings and instructions stated in the Safety Messages. Always use good common sense to avoid hazards. (SG-2)



Si no lee ingles, pida ayuda a alguien que si lo lea para que le traduzca las medidas de seguridad. (SG-3)

¡ LEA EL INSTRUCTIVO!



Standard Equipment and Specifications

BASE UNIT SPECIFICATIONS

21'8" Overall Cutting Width
3/8" Box Fully Welded Frame
19-Gallon Reservoir with 10 Micron Filtration
Tandem Piston Pumps Rated @ 48 GPM @ 3800 PSI
Standard 1 year limited parts and labor warranty

WING MOWER SPECIFICATIONS

VERSA PRO 03/09

Operation Section 4-2

OPERATION

88" Cutting Width
Two 10-Gauge Unitized Cutter Housings
1/2" Inboard and 5/16" Wall Cuttershaft
Replaceable Skid Shoes
4-1/2" x 5/16" Wall Cuttershaft
1-5/16" Bore Greasable, Self-aligning Cuttershaft Bearings
53 HP Motor
Belt Drive From Motor to Cuttershaft with Automatic Spring Tension
6" Adjustable Rear Roller
1/2" to 6" Cutting Height
Available in Fine or Coarse-Cut
Front and Rear Safety Deflectors
Automatic Cut-Off Switches
Wing Cylinder Capable of 145 degrees Down & 90 degrees Up

FRONT MOWER SPECIFICATIONS

96" Cutting Width
10-Gauge Unitized Cutter Housing
5/16" Side Plates
4-1/2" x 5/16" Wall Cuttershaft
1-5/16" Bore Greasable, Self-aligning Cuttershaft Bearings
60 HP Gearbox
6" Adjustable Rear Roller
1/2" to 6" Cutting Height
Available in Fine or Coarse Cut
Front and Rear Safety Deflectors
Belt Drive from Gearbox to Cuttershaft with Automatic Spring Tension



The Mower is designed for certain mowing applications and is rated to cut up to a specific size vegetation (see Mower Standard Equipment and Specifications). DO NOT use this mower to cut vegetation above the Mower's rated capacity or to cut any type of non-vegetative material. Only operate this Mower on a properly sized and equipped Tractor. Operating this Mower in an application for which it is not designed and/or operating the Mower with the wrong size Tractor can cause Mower component damage and equipment failure resulting in possible serious injury or death. (SGM-14)

OPERATION

1. OPERATOR REQUIREMENTS

Safe operation of the unit is the responsibility of a qualified operator. A qualified operator has read and understands the implement and tractor Operator's Manuals and is experienced in implement and tractor operation and all associated safety practices. In addition to the safety messages contained in this manual, safety signs are affixed to the implement and tractor. If any part of the operation and safe use of this equipment is not completely understood, consult an authorized dealer for a complete explanation.

If the operator cannot read the manuals for themselves or does not completely understand the operation of the equipment, it is the responsibility of the supervisor to read and explain the manuals, safety practices, and operating instructions to the operator.

Safe operation of equipment requires that the operator wear approved Personal Protective Equipment (PPE) for the job conditions when attaching, operating, servicing, and repairing the equipment. PPE is designed to provide operator protection and includes the following safety wear:

PERSONAL PROTECTIVE EQUIPMENT (PPE)

- Protective Eye Glasses, Goggles, or Face Shield
- Hard Hat
- Steel Toe Safety Footwear
- Gloves
- Hearing Protection
- Close Fitting Clothing
- Respirator or Filter Mask (depends on operating conditions) *OPS-U- 0002*

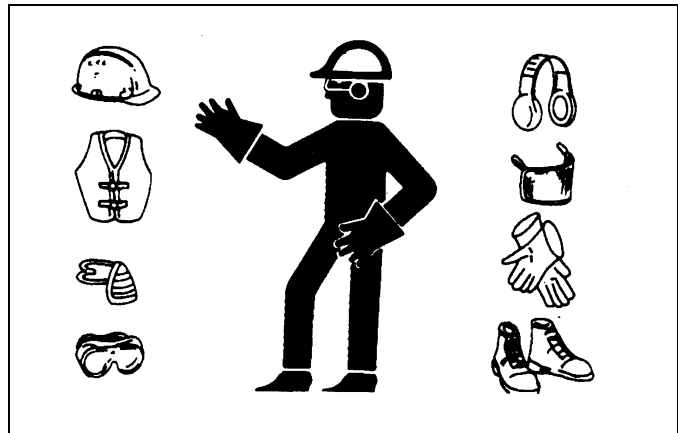

NEVER use drugs or alcohol immediately before or while operating the Tractor and Implement. Drugs and alcohol will affect an operator's alertness and coordination and therefore affect the operator's ability to operate the equipment safely. Before operating the Tractor or Implement, an operator on prescription or over-the-counter medication must consult a medical professional regarding any side effects of the medication that would hinder their ability to operate the Equipment safely. NEVER knowingly allow anyone to operate this equipment when their alertness or coordination is impaired. Serious injury or death to the operator or others could result if the operator is under the influence of drugs or alcohol. (SG-27)

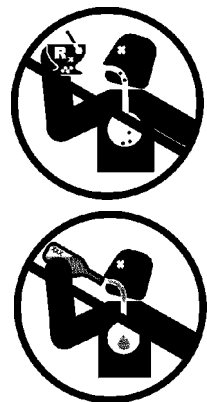

TRACTOR REQUIREMENTS

The tractor used to operate the mower must have the power, capacity and required equipment to safely operate the mower at a ground speed between 2 and 5 MPH. Operating the mower with a tractor that does not meet the following requirements may cause tractor or mower damage and could be a potential danger to the operator and passersby.

OPERATION

Tractor Requirements and Capabilities

- ASAE approved Roll-Over Operator Protective Structure (ROPS) or ROPS cab and Seatbelt.
- Tractor Safety DevicesSlow Moving Vehicle (SMV) emblem, lighting, PTO master shield
- Tractor Horsepower -MinimumVersa Pro Flail 90 HP
- Hydraulics.....2 piston pumps and motors are used with a 26-gallon hydraulic reservoir
- Front End Weights.....As needed to maintain 20% weight on tractor front axle
- Power Take Off.....540 RPM

1.1 ROPS and Seat Belt

The tractor must be equipped with a Roll-Over-Protective-Structure (ROPS) (tractor cab or roll-bar) and seat belt to protect the operator from falling off the tractor, especially during a roll over where the driver could be crushed and killed. Only operate the tractor with the ROPS in the raised position and seat belt fastened. Tractor model not equipped with a ROPS and seat belt should have these life saving features installed by an authorized dealer. *OPS-U- 0003*



Operate this Equipment only with a Power Unit equipped with an approved operator Roll-Over Protective Structure (ROPS). Always wear seat belts. Serious injury or even death could result from falling off the Power Unit--particularly during a turnover when the operator could be pinned under the Operator Protective Structure. (SPU-14)



1.2 Tractor Safety Devices

If transporting or operating the tractor and implement near a public roadway, the tractor must be equipped with proper warning lighting and a Slow Moving Vehicle (SMV) emblem which are clearly visible from the rear of the unit. Lights and a SMV emblem must be equipped directly on implements if the visibility of the tractor warning signals are obscured.

Maintain all manufacturer equipped safety shields and guards. Always replace shields and guards that were removed for access to connect, service, or repair the tractor or implement. Never operate the tractor PTO with the PTO master shield missing or in the raised position. *OPS-U- 0004*

OPERATION

1.3 Tractor Horsepower

The horsepower required to operate the mower depends on many factors including the vegetation to be cut, terrain condition, operator experience, and condition of the mower and tractor. For most mowing condition, the Versa Pro flail mower require a tractor with at least 90HP. Operating the mower with a tractor that does not have adequate power may damage the tractor engine.

1.4 Tractor Hydraulics

The mower wings are hydraulically powered from the PTO shaft at the cab end of the tractor. Two piston pumps and motors are used with a 26-gallon hydraulic reservoir.

1.5 Front End Weight

A minimum of 20% total tractor weight must be maintained on the tractor front end at all times. Front end weight is critical to maintain steering control and to prevent the tractor from rearing up while driving. If the front end is too light, add weight until a minimum of 20% total weight is reached on the front tires. Front weights and weight carriers can be purchased through an authorized tractor dealership. *OPS-U- 0005*

1.6 Power Take Off (PTO)

Depending on the unit, the mower is designed to operate at a PTO speed of 540 or 1000 RPM. Most tractors operate at either 540, or a combination of 540 and 1000 RPM PTO speeds. The operating speed of the mower and tractor can be determined by the number of splines on the driveline yoke and PTO output shaft. Those operating at 540 RPM will have a 6-spline shaft and those operating at 1000 RPM will have a 21-spline shaft or a 1-3/4" 20 spline shaft. Refer to the tractor owner's manual for instructions to change PTO speeds on models that operate at more than one speed.

If operating an older model tractor where the tractor's transmission and PTO utilize one master clutch, an over-running clutch must be used between the PTO output shaft and the driveline of the mower. An authorized tractor dealer can provide the over-running clutch and its installation if needed. *OPS-U- 0006*

DANGER

DO NOT use a PTO adapter to attach a non-matching Implement driveline to a Tractor PTO. Use of an adapter can double the operating speed of the Implement resulting in excessive vibration, thrown objects, and blade and implement failure. Adapter use will also change the working length of the driveline exposing unshielded driveline areas. Serious bodily injury and/or equipment failure can result from using a PTO adapter. Consult an authorized dealer for assistance if the Implement driveline does not match the Tractor PTO.

(S3PT-14)

WARNING

Never operate the Tractor and Mower if the Implement input driveline is directly connected to the Tractor transmission. Tractor braking distances can be substantially increased by the momentum of the rotating Mower blades driving the Tractor transmission even though the Tractor clutch has been disengaged. Install an over running clutch between the Tractor PTO and the Mower driveline to prevent this potentially dangerous situation. (S3PT-16)

OPERATION

2. GETTING ON AND OFF THE TRACTOR

Before getting onto the tractor, the operator must read and completely understand the implement and tractor operator manuals. If any part of either manual is not completely understood, consult an authorized dealer for a complete explanation. *OPS-U- 0007*



Do not mount or dismount the Tractor while the tractor is moving. Mount the Tractor only when the Tractor and all moving parts are completely stopped. (SG-12)



2.1 Boarding the Tractor

Use both hands and equipped handrails and steps for support when boarding the tractor. Never use control levers for support when mounting the tractor. Seat yourself in the operator's seat and secure the seat belt around you.

Never allow passengers to ride on the tractor or attached equipment. Riders can easily fall off and be seriously injured or killed from falling off and being ran over. It is the operator's responsibility to forbid all extra riders at all times. *OPS-U- 0008*



Never allow children or other persons to ride on the Power Unit or Implement. Falling off can result in serious injury or death. (SPU-16)



Never allow children to operate or ride on the Power Unit or Implement. (SPU-17)



2.2 Dismounting the Tractor

Before dismounting, park the tractor and implement on a reasonably level surface, apply the parking brake, idle the engine down, disengage the PTO, and lower the implement to the ground. Shut down the tractor engine according to the operator's manual, remove the key, and wait for all motion to completely stop. Never leave the seat until the tractor, its engine and all moving parts have come to a complete stop.

Use hand rails and steps when exiting the tractor. Be careful of your step and use extra caution when mud, ice, snow or other matter has accumulated on the steps or hand rails. Use all handrails and steps for support and never rush or jump off the tractor. *OPS-U- 0009*

OPERATION



BEFORE leaving the tractor seat, always engage the brake and/or set the tractor transmission in parking gear, disengage the PTO, stop the engine, remove the key, and wait for all moving parts to stop. Place the tractor shift lever into a low range or parking gear to prevent the tractor from rolling. Never dismount a Tractor that is moving or while the engine is running. Operate the Tractor controls from the tractor seat only. (SG-9)

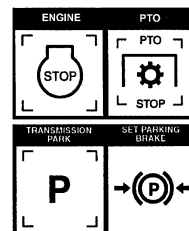

OPERATION

3. STARTING THE TRACTOR

The operator must have a complete understanding of the placement, function, and operational use of all tractor controls before starting the tractor. Review the tractor's operator's manual and consult an authorized dealer for operating instructions if needed.

Essential Tractor Controls:

- Locate the ignition switch
- Locate the engine shut off control
- Locate the engine throttle control
- Locate the brake pedals and the clutch
- Locate the parking brake
- Locate the PTO control
- Locate the 3-point hitch control lever
- Locate the hydraulic control lever
- Locate the light control switch

Before starting the tractor ensure the following:

- Conduct all pre-start operation inspection and service according to the skid steer operator's manual.
- Make sure all guards, shields, and other safety devices are securely in place.
- The parking brake is on.
- The PTO control lever is disengaged.
- The hydraulic remote control valve levers are in the neutral or float position.
- The tractor transmission gear is in park or neutral.

Refer to the tractor owner's manual for tractor starting procedures. Only start the tractor while seated and belted in the tractor operator's seat. Never bypass the ignition switch by short circuiting the starter solenoid.



Never run the Tractor engine in a closed building or without adequate ventilation. The exhaust fumes can be hazardous to your health. (SG-23)



Start tractor only when properly seated in the Tractor seat. Starting a tractor in gear can result in injury or death. Read the Tractor operators manual for proper starting instructions. (SG-13)



CONNECTING THE MOWER TO THE TRACTOR

Use extreme caution when connecting the mower to the tractor. The mower should be securely resting at ground level or on blocks. Place a block in front of and behind the tires to prevent the mower from moving. Keep hands and feet out from under the mower and clear of pinch points between the tractor and

OPERATION

mower.



Always shut the Tractor completely down, place the transmission in park, and set the parking brake before you or anyone else attempts to connect or disconnect the Implement and Tractor hitches. (S3PT-15)



Do not operate this Equipment with hydraulic oil or fuel leaking. Oil and fuel are explosive and their presence could present a hazard. Do not check for leaks with your hand! High-pressure oil streams from breaks in the line could penetrate the skin and cause tissue damage including gangrene. To check for a hose leak, SHUT the unit ENGINE OFF and remove all hydraulic pressure. Wear oil impenetrable gloves, safety glasses and use Cardboard to check for evidence of oil leaks. If you suspect a leak, REMOVE the HOSE and have it tested at a Dealer. If oil does penetrate the skin, have the injury treated immediately by a physician knowledgeable and skilled in this procedure. (SG-15)



4. SETTING THE MOWER

Properly setting the cutting height is essential for efficient and safe operation. A properly set mower will make a more uniform cut, distribute clippings more evenly, require minimal tractor work, and follow the contour of uneven terrain. **NOTE:** *Avoid very low cutting heights, striking the ground with the blades gives the most damaging shock loads and will cause damage to the mower and drive. Blades contacting the ground may cause objects to be thrown out from under the mower deck. Always avoid operating the mower at a height which causes the blades to contact the ground.* OPS-U- 0010



Never work under the Implement, the framework, or any lifted component unless the Implement is securely supported or blocked up to prevent sudden or inadvertent falling which could cause serious injury or even death. (SG-14)



OPERATION

Roller Height Adjustment

The mower's cutting height is set by positioning the roller assembly for each mower section. Each section must be set at the same height to ensure an even cut across the entire width of the mower.

1. Place the tractor and mower on a level surface and completely lower the mower to the ground.
2. Shut down the tractor, place the transmission in park, and set the parking brake before dismounting.
3. One section at a time, place lifting device (scissors jack or hydraulic jack) under center of cutter housing.
4. Remove hex nuts, washers and carriage bolts from bracket at each end of roller. Make certain that roller bracket is free to move once the fasteners are removed. A stuck roller could drop unexpectedly and cause injury.
5. Use lifting device to reposition cutter housing to desired cutting height. Align bracket holes with cutter housing, then reinstall hardware.
6. Lower cutter housing to the ground and remove lifting device.
7. Set cutting height according to procedures above for remaining two cutter sections. Make sure that all three rollers are set at the same height to ensure an even cut across the entire width of the mower.

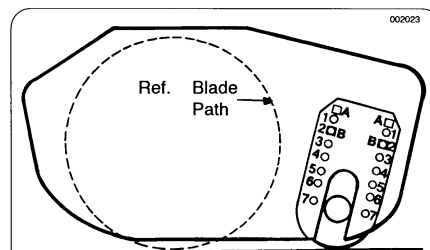
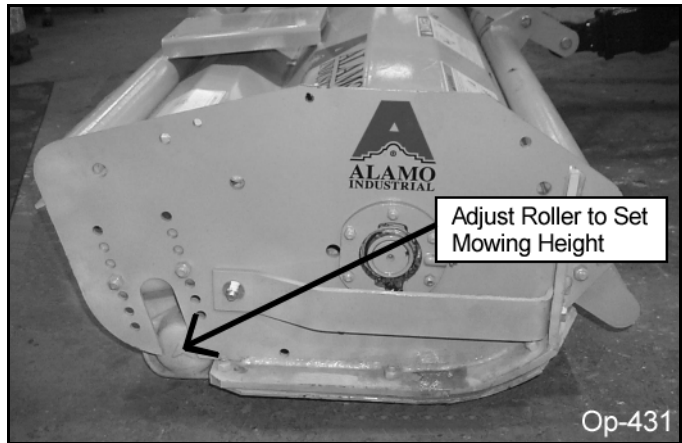

MOWER CUTTING HEIGHT ADJUSTMENT

DESIRED CUTTING HEIGHT (INCHES)	ADJUSTMENT BRACKET HOLE	MOWER END PLATE HOLE
1/2	B	2
1	A	1
1-1/2	B	3
2	A	2
2-1/2	B	4
3	A	3
3-1/2	B	5
4	A	4
4-1/2	B	6
5	A	5
5-1/2	B	7
6	A	6

Leveling Deck

To Facilitate a safe and efficient mowing operation, the mower should be operated parallel to the ground at all times. Never operate if front or rear of mower is tilted upward. Objects may be discharged at high speeds causing possible injury or even death.

Adjust Top Link to level mower roller adjustment. Side Skid Shoes should always be parallel to ground throughout the full adjustment range. Adjust cutting height of machine by raising or lowering rear roller as specified in Operation Section.

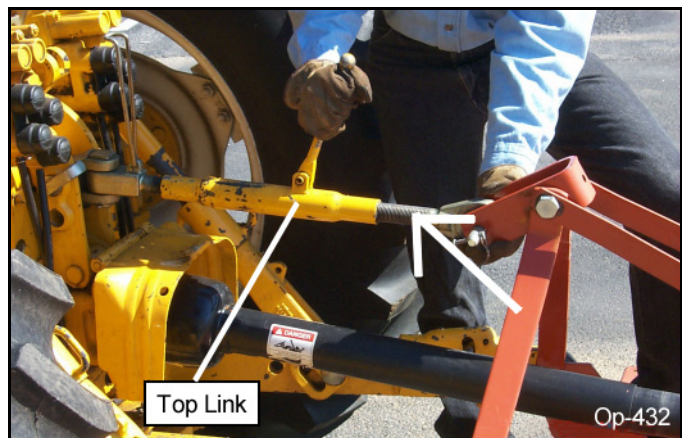

OPERATION

WARNING

Do not let the Blades turn when the Mower Deck is raised for any reason, including clearance or for turning. Raising the Mower deck exposes the Cutting Blades which creates a potentially serious hazard and could cause serious injury or even death from objects thrown from the Blades. (SRM-07)



5. DRIVELINE ATTACHMENT

The driveline yoke and tractor PTO shaft must be dirt free and greased for easy and secure attachment.

To connect the mower driveline to the tractor PTO output shaft, pull the driveline yoke collar back and align the grooves and splines of the yoke with those of the PTO shaft. Push the driveline yoke onto the PTO shaft, release the locking collar, and position the yoke until the locking collar is securely attached to the PTO shaft. Push and pull the driveline back and forth several times to ensure a secure attachment.



WARNING

When attaching the Implement input driveline to the Tractor PTO, it is important that the connecting yoke spring activated locking collar slides freely and the locking balls are seated securely in the groove on the Tractor PTO shaft. Push and pull the driveline back and forth several times to ensure it is securely attached. A driveline not attached correctly to the Tractor PTO shaft could come loose and result in personal injury and damage to the Implement. (S3PT-17)

5.1 Driveline Length Check

WARNING

Before operating the Implement, check to make sure the Implement input driveline will not bottom out or become disengaged. Bottoming out occurs when the inner shaft penetrates the outer housing until the assembly becomes solid-it can shorten no more. Bottoming out can cause serious damage to the Tractor PTO by pushing the PTO into the Tractor and through the support bearings or downward onto the PTO shaft, breaking it off. A broken driveline can cause personal injury. (S3PT-18)

When fitting the mower to the tractor, the telescoping driveline must be inspected to ensure that at its most compressed position, the profiles do not "bottom out", and when at its farthest extended position, there is sufficient engagement between the profiles to operate safely. At its shortest length, there must be at least a 1" clearance between each profile end and opposite profile universal joint. At its farthest operating extension, a minimum profile engagement of 8" must be maintained.

OPERATION

“Bottoming Out” Check Procedure

1. Disconnect driveline from the tractor and slide the profiles together until fully compressed.
2. Place a mark on the inner shield 1/8” from the end of the outer shield and reattach the driveline to the PTO shaft.
3. With the **PTO NOT TURNING**, slowly drive the tractor with mower attached through the sharpest turn possible and watch shaft movement. With the **PTO NOT TURNING**, slowly drive the tractor with the mower attached through the most severe terrain conditions expected and watch shaft movement.
4. If the distance between the mark and the outer shield becomes less than 2” at any point there is a potential problem bottoming out the driveline and the driveline should be shortened.

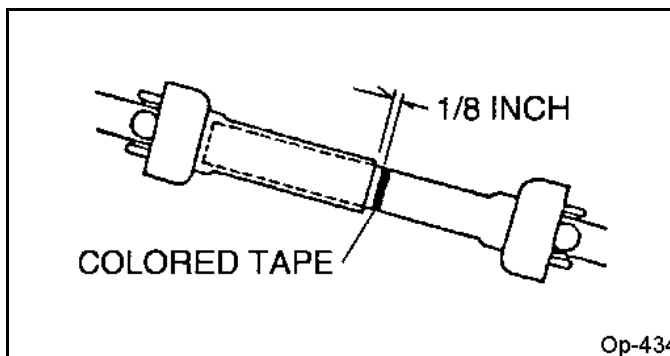

Shorten the driveline profiles as follows:

1. Remove the driveline from the tractor.
2. Position the mower to the point with the shortest distance between the tractor PTO shaft and cutter gearbox. Shut down the tractor and securely block the mower in this position.
3. Pull driveline apart and reattach yoke to PTO shaft.
4. Hold driveline sections parallel to one another and measure back 1” from yoke of each shaft and place mark on opposite section. Cut this length off with a saw.
5. Round off all sharp edges and debar.
6. Thoroughly grease then reinstall the driveline.
7. Recheck for proper operation.

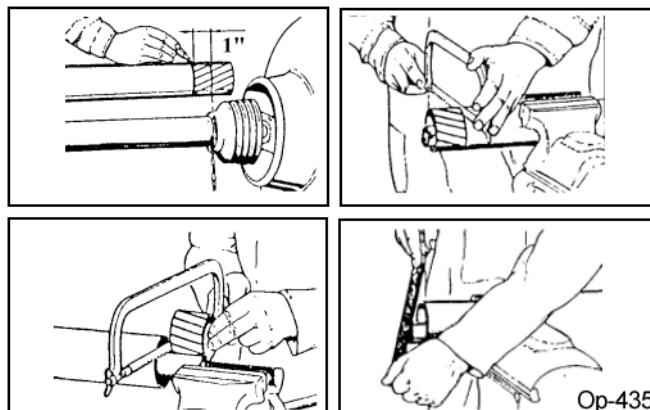

Engagement Check Procedure

1. With the driveline attached, position the mower to the point where the telescoping driveline is at its maximum extension. Completely shut down the tractor and secure in position.
2. Mark the inner driveline shield 1/8” from the end of the outer shield.
3. Disconnect the driveline from the tractor and separate the two driveline halves.
4. Measure the distance from the mark to the end of the inner profile. This length is the amount the driveline profiles were engaged.
5. If the engaged length is less than 8”, the shaft is considered too short and should be replaced with a longer shaft. Consult an authorized dealer to purchase the required driveline length.

NOTE: If the driveline cannot be shortened and still maintain the required profile engagement, the operator must be made aware of terrain conditions and avoid situations which pose a potential problem to avoid damaging the driveline.

OPERATION

6. PRE-OPERATION INSPECTION AND SERVICE

Before each use, a pre-operation inspection and service of the implement and tractor must be performed. This includes routine maintenance and scheduled lubrication, inspecting that all safety devices are equipped and functional, and performing needed repairs. DO NOT operate the unit if the pre-operation inspection reveals any condition affecting safe operation. Perform repairs and replacement of damaged and missing parts as soon as noticed. By performing a thorough pre-operation inspection and service, valuable down time and repair cost can be avoided. OPS-U-0029



Always disconnect the main PTO Driveline from the Tractor before performing service on the Implement. Never work on the Implement with the tractor PTO driveline connected and running. Rotating Parts, Blades or Drivelines could turn without warning and cause immediate entanglement, injury or death. (S3PT-11)



DO NOT allow any person under a folded wing unless wing is securely locked up or supported. **DO NOT** approach the Implement unless the Tractor is turned off and all motion has ceased. Never work under the frame work, or any lifted component unless the implement is securely supported or blocked up. A sudden or inadvertent fall by any of these components could cause serious injury or even death. (STI-03)



OPERATION

6.1 Mower Pre-Operation Inspection/Service

Before each mower use, a complete inspection and service is required to ensure the mower is in a good and safe working condition. Damaged and/or broken parts should be repaired and/or replaced immediately. To ensure the mower is ready for operation, conduct the following.



Periodically inspect all moving parts for wear and replace when necessary with authorized service parts. Look for loose fasteners, worn or broken parts, and leaky or loose fittings. Make sure all pins have cotter pins and washers. Serious injury may occur from not maintaining this machine in good working order. (SG-21)

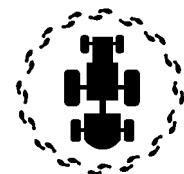

OPERATION

6.2 Tractor Pre-Operation Inspection/Service

Refer to the tractor operator's manual to ensure a complete pre-operation inspection and scheduled service is performed according to the manufacturers recommendations. The following are some of the items that require daily service and inspection:

- Tire condition/air pressure
- Wheel lug bolts
- Steering linkage
- PTO shield
- SMV sign is clean and visible
- Tractor's lights are clean and functional
- Tractor Seat belt is in good condition
- Tractor ROPS is in good condition
- ROPS is in the raised position
- No tractor oil leaks
- Radiator free of debris
- Engine oil level and condition
- Engine coolant level and condition
- Power brake fluid level
- Power steering fluid level
- Fuel condition and level
- Sufficient lubrication at all lube points
- Air filter condition OPS-U-0030



All Safety Shields, Guards and Safety devices including (but not limited to) - the Deflectors, Steel Guards, Gearbox Shields, PTO integral shields, and Retractable Door Shields should be used and maintained in good working condition. All safety devices should be inspected carefully at least daily for missing or broken components. Missing, broken, or worn items must be replaced at once to reduce the possibility of injury or death from thrown objects, entanglement, or blade contact. (SFL-5)

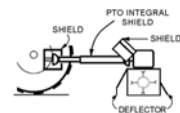

Replace bent or broken blades with new blades. NEVER ATTEMPT TO STRAIGHTEN, WELD, OR WELD HARDFACING ON BLADES SINCE THIS WILL LIKELY CRACK OR OTHERWISE DAMAGE THE BLADE WITH SUBSEQUENT FAILURE AND POSSIBLE SERIOUS INJURY FROM THROWN BLADES. (SGM-10)

OPERATION

The operator's manual and safety signs affixed on the unit contain important instructions on the safe and proper use of the equipment. Maintain these important safety features on the implement in good condition to ensure the information is available to the operator at all times.

- Ensure the manual canister is secured to the equipment with the operator's manual inside.
- Ensure all safety signs are in place and legible. Replace missing, damaged, and illegible decals. *OPS-U-0011*



- Check that the main driveline is securely attached to the tractor and the locking collar is seated in the groove of the PTO shaft.
- Ensure the mower A-Frame is securely attached to the tractor's 3-point hitch with a proper size bolt and secured nut.
- Ensure that a properly rated safety tow chain is equipped securing the mower to the tractor. *OPS-F-0037*



KEEP AWAY FROM ROTATING ELEMENTS to prevent entanglement and possible serious injury or death. (SG-24)



- Ensure rubber deflectors are in position and not damaged. Replace worn, broken, and missing sections immediately.
- Ensure the rollers are in good condition and rotate freely.
- Inspect that all bolts and screws are in position and are properly torqued. *OPS-F-0038*



OPERATION

OPERATION

- Inspect the condition of the drive belts.
- Ensure the slip clutch is properly adjusted and the friction plates are not frozen together. Reference the Maintenance Section for proper slip clutch maintenance.
- Ensure the slip clutch shield and drive belt shields are in place and in good repair.
- Ensure the tractor PTO master shield is in place, lowered and in good condition. OPS-F-0039



- Check the oil level in tank and replenish if needed. **NOTE:** Do not fill the tank with oil above the level of the sight gauge. Overfilling the tank with oil after initial filling may result in oil being discharged through the air filter on the top of the hydraulic tank.
- Perform scheduled lubrication as specified in the maintenance section. OPS-F-0040

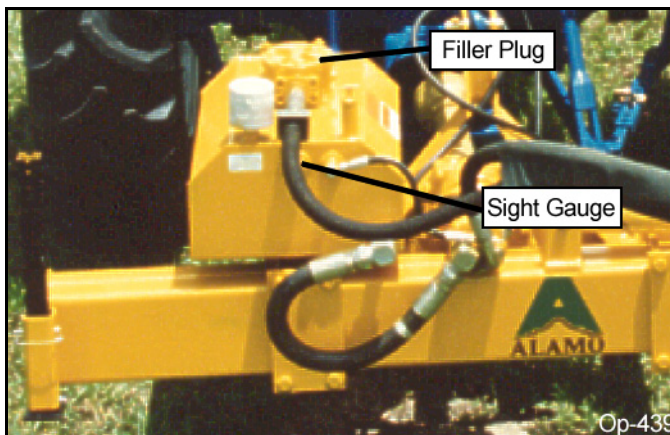

- Inspect cutter knives and knife pins for looseness and excessive wear. Make sure the mower is securely blocked up before crawling beneath. Replace damaged, worn, and missing knives as complete sets to maintain cuttershaft balance.
- Remove any grass or other debris which may be wrapped around the cuttershafts.
- Inspect the condition of deck skid shoes and hardware. OPS-F-0041

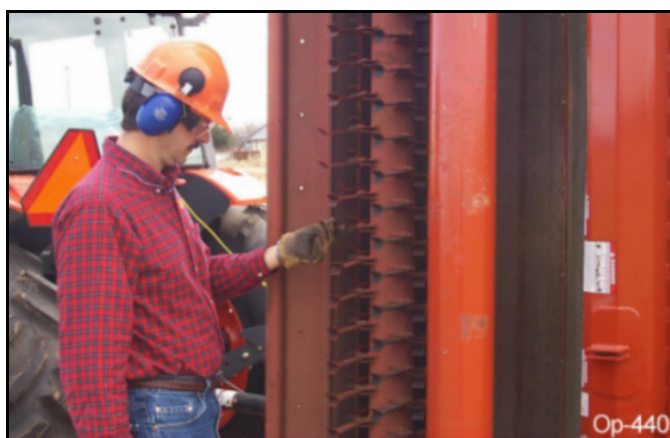

OPERATION

- Check for hydraulic oil leaks on the cylinders, along the hydraulic lines, and at tractor hydraulic ports.
- Ensure each hydraulic cylinder is installed and retained correctly. Ensure the proper size pins are used to retain the cylinders in place and are secured with pins.
- Check the condition of the flail unit hinge pins.
- Check the overall condition of the mower main frame.
- Inspect mower tire condition, wheel bearings, and lug nut torque. OPS-F-0042_A



WARNING

Do not operate this Equipment with hydraulic oil or fuel leaking. Oil and fuel are explosive and their presence could present a hazard. Do not check for leaks with your hand! High-pressure oil streams from breaks in the line could penetrate the skin and cause tissue damage including gangrene. To check for a hose leak, SHUT the unit ENGINE OFF and remove all hydraulic pressure. Wear oil impenetrable gloves, safety glasses and use Cardboard to check for evidence of oil leaks. If you suspect a leak, REMOVE the HOSE and have it tested at a Dealer. If oil does penetrate the skin, have the injury treated immediately by a physician knowledgeable and skilled in this procedure. (SG-15)



OPERATION

Flail-Wing Mower PRE-OPERATION Inspection



Mower ID# _____ Make _____

Date: _____ Shift _____



Before conducting the inspection, make sure the tractor engine is off, all rotation has stopped and the tractor is in park with the parking brake engaged. Make sure the mower is resting on the ground or securely blocked up and all hydraulic pressure has been relieved.

OPERATION

Item	Condition at Start of Shift	Specific Comments if not O.K.
The Operator's Manual is in the canister on the mower		
All safety decals are in place and legible		
The Mounting frame bolts are in place and tight		
The Wing connection bolts & pins are tight		
The Hydraulic Cylinders pins are tight		
The Hydraulic Pump hose connections are tight		
The Hydraulic Valve hose connections are tight		
The Hydraulic Valve controls function properly		
There are no leaking or damaged hoses		
The Hydraulic Oil level is full		
Blades are not broken, chipped, cracked or bent		
Blade shackles are in good condition with no cracks		
The Blade pins are properly retained		
Their Guards/Deflectors are in good condition		
The Driveline clutch is in good condition, not frozen		
The Driveline tubes & u-joints have been lubricated		
The Driveline yoke is securely attached to the PTO		
The Gearbox oil level is full		
The rear roller is in good condition and turns freely		

Operator's Signature: _____

DO NOT OPERATE an UNSAFE TRACTOR or MOWER

OPERATION

Tractor PRE-OPERATION Inspection



Mower ID# _____ Make _____

Date: _____ Shift _____



Before conducting the inspection, make sure the tractor engine is off, all rotation has stopped and the tractor is in park with the parking brake engaged. Make sure the mower is resting on the ground or securely blocked up and all hydraulic pressure has been relieved.

OPERATION

Item	Condition at Start of Shift	Specific Comments if not O.K.
The flashing lights function properly		
The SMV Sign is clean and visible		
The tires are in good condition with proper pressure		
The wheel lug bolts are tight		
The tractor brakes are in good condition		
The steering linkage is in good condition		
There are no visible oil leaks		
The hydraulic controls function properly		
The ROPS or ROBS Cab is in good condition		
The seatbelt is in place and in good condition		
The 3-point hitch is in good condition		
The drawbar pins are securely in place		
The PTO master shield is in place		
The engine oil level is full		
The brake fluid level is full		
The power steering fluid level is full		
The fuel level is adequate		
The engine coolant fluid level is full		
The radiator is free of debris		
The air filter is in good condition		

Operator's Signature: _____

DO NOT OPERATE an UNSAFE TRACTOR or MOWER

This Inspection Form may be freely duplicated for extra copies.

OPERATION

7. DRIVING THE TRACTOR AND IMPLEMENT

Safe tractor transport requires the operator possess a thorough knowledge of the model being operated and precautions to take while driving with an attached implement. Ensure the tractor has the capacity to handle the weight of the implement and the tractor operating controls are set for safe transport. To ensure safety while driving the tractor with an attached implement, review the following. *OPS-U- 0012*

Read all safety instructions. Decals on the mower warn you of particular and multiple hazards. Some decals are attached close to part of the mower where there is a possible hazard. Read and make sure you understand the safety message before you operate the implement. Keep all decals clean and readable. Replace lost or damaged decals.

Power for operating the mower is supplied from the tractor PTO. Refer to your tractor manual instructions for engaging and disengaging the PTO. Start the tractor and idle at a slow engine speed until oil is being pumped. Always engage the PTO at low engine PTO speed and run the mower for a short period until all air is removed from the hoses. Keep all person's well clear of mower since blades can throw objects with great velocity for a considerable distance! **KEEP CLEAR!**

Check the fluid level in the Hydraulic Tank and add oil if required. As the air has been forced out of the Hoses, it goes into the Hydraulic Tank and reduces the volume of oil. Maintain the oil level within the sight gauge located on the side of the reservoir. Never fill the tank above the sight gauge to allow for the expansion of the oil. The tank maintains pressure after the mower has been run. Stand off to one side when removing the breather cap element to prevent possible injury. To relieve pressure remove the breather cap element and depress the spring loaded pressure valve to release any excess air. Fill with Dexron® II Automatic Transmission Fluid.



This Implement is wider than the Tractor. Be careful when operating or transporting this equipment to prevent the Implement from running into or striking sign posts, guard rails, concrete abutments or other solid objects. Such an impact could cause the Implement and Tractor to pivot violently resulting in loss of steering control, serious injury, or even death. Never allow the Implement to contact obstacles. (S3PT-12)

OPERATION

WARNING

Transport only at speeds where you can maintain control of the equipment. Serious accidents and injuries can result from operating this equipment at high speeds. Understand the Tractor and Implement and how it handles before transporting on streets and highways. Make sure the Tractor steering and brakes are in good condition and operate properly.



Before transporting the Tractor and Implement, determine the proper transport speeds for you and the equipment. Make sure you abide by the following rules:

Test the tractor at a slow speed and increase the speed slowly. Apply the Brakes smoothly to determine the stopping characteristics of the Tractor and Implement. As you increase the speed of the Tractor the stopping distance increases. Determine the maximum transport speed not to exceed 20 mph (30 kph) for transporting this equipment.

Test the equipment at a slow speed in turns. Increase the speed through the turn only after you determine that the equipment can be operated at a higher speed. Use extreme care and reduce your speed when turning sharply to prevent the tractor and implement from turning over. Determine the maximum turning speed for you and this equipment before operating on roads or uneven ground.



Only transport the Tractor and Implement at the speeds which allow you to properly control the equipment.

Be aware of the operating conditions. Do not operate the Tractor with weak or faulty brakes or worn tires. When operating down a hill or on wet or rain slick roads, the braking distance increases: use extreme care and reduce your speed. When operating in traffic always use the Tractor's flashing warning lights and reduce your speed. Be aware of traffic around you and watch out for the other guy. (SG-19)

7.1 Starting the Tractor

The procedure to start the tractor is model specific. Refer to the tractor operator's manual for starting procedures for your particular tractor. Consult an authorized dealer if the starting procedure is unclear. Ensure the 3-point control lever is in the lowered position and the PTO is disengaged before starting the tractor. OPS-U-0033



OPERATION

7.2 Brake and Differential Lock Setting

Make sure the tractor brakes are in good operating condition. Tractor brakes can be set to operate independently allowing single rear wheel braking action or locked together to provide simultaneous rear wheel braking. FOR MOST DRIVING AND OPERATING CONDITIONS, THE BRAKE PEDALS SHOULD BE LOCKED TOGETHER TO PROVIDE THE MOST EFFECTIVE BRAKING ACTION.

Always disengage the tractor differential lock when turning. When engaged the differential lock will prevent or limit the tractor from turning. During normal cutting conditions, locking the differential provides no benefit and should not be used.
OPS-U-0013

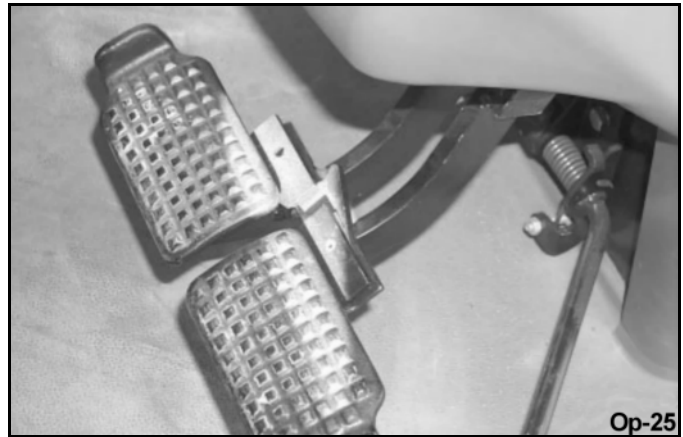

WARNING

Be aware of the operating conditions. Do not operate the Tractor with weak or faulty brakes. When operating down a hill or on wet or rain slick roads, the braking distance increases; use extreme care and reduce your speed in these conditions. When operating in traffic, always use the Tractor's flashing warning lights and reduce your speed. Be aware of traffic around you and watch out for the other guy.

7.3 Operating the Mower Wing

Transport Position

With tractor engine running, turn off the tractor PTO Switch and wait for cuttershaft(s) to stop rotating. Using the tractor remote lever to fully raise mower wing unit.

Then lift up transport link to pin attaching cylinder to actuator on A-frame. Attach pin clip once the pin is through the transport link hole and attach the clip pin to keep in place.

Make certain that the control lever is in the "HOLD" position when transporting unit.

OPS-F-0045



WARNING

Do not let the Blades turn when the Mower Deck is raised for any reason, including clearance or for turning. Raising the Mower deck exposes the Cutting Blades which creates a potentially serious hazard and could cause serious injury or even death from objects thrown from the Blades. (SRM-07)



The mower's center of gravity is raised making the mower more prone to tipping when the wings are in the raised position. Use extreme caution when towing the mower in the transport position and avoid uneven

OPERATION

terrain which could upset the mower.



When the Wings are folded for transport, the center of gravity is raised and the possibility of overturn is increased. Drive slowly and use extreme caution when turning on hillsides. Overturning the Implement could cause the Implement to overturn the Tractor and vice versa resulting in serious injury or even death. Never fold wings on a hillside...the Implement may overturn. (STI-02)

Operating Position

Ensure that the PTO Switch is in the OFF position. With tractor engine running, pull LIFT control lever rearward until wing is fully retracted in and there is no tension on the transport link. Take clip pin from the pin holding the transport link and cylinder on the actuator. Once transport link has been freed move transport link to the welded holding bracket on the frame. Finally slowly lower the wing down to the ground and then engage the levers into the float position. OPS-F-0046



Use extreme care when lowering or unfolding the implement's wings. Make sure no bystanders are close by or underneath the wings. Allow ample clearance around the implement when folding or unfolding the wings. Use extreme caution around buildings or overhead power lines. (S3PT-05)



Do not put hands or feet under mower decks. Blade Contact can result in serious injury or even death. Stay away until all motion has stopped and the decks are securely blocked up. (SFL-2)



Flail Mowers are capable under adverse conditions of throwing objects for great distances (100 yards or more) and causing serious injury or death. Follow safety messages carefully.



OPERATION

7.4 Driving the Tractor and Implement

Start off driving at a slow speed and gradually increase your speed while maintaining complete control of the tractor and unit. Moving slowly at first will also prevent the tractor from rearing up and loss of steering control. The tractor should never be operated at speeds that cannot be safely handled or which will prevent the operator from stopping quickly during an emergency. If the power steering or engine ceases operating, stop the tractor immediately as the tractor will be difficult to control.

Perform turns with the tractor and units at slow speeds to determine how the tractor with an attached blade or rake handles a turn. Determine the safe speed to maintain proper control of the tractor when making turns. When turning with a towed implement, the overall working length of the unit is increased. Allow additional clearance for the units when turning.

To avoid overturns, drive the tractor with care and at safe speeds, especially when operating over rough ground, crossing ditches or slopes, and turning corners. Tractor wheel tread spacing should be increased when working on inclines or rough ground to reduce the possibility of tipping.

Use extreme caution when operating on steep slopes. Keep the tractor in a low gear when going downhill. DO NOT coast or free-wheel downhill. *OPS-U-0014*

7.5 Crossing Ditches and Steep Inclines

When crossing ditches with steep banks or going up sharp inclines, it is possible that the main driveline inner profile will penetrate into the outer housing to its maximum depth until the assembly becomes solid (driveline is at its extreme shortest length). This type of abusive operation can cause serious damage to the tractor and mower drive by pushing the PTO into the tractor and through the support bearings or downward onto the PTO shaft, breaking it off.

OPS-F-0049

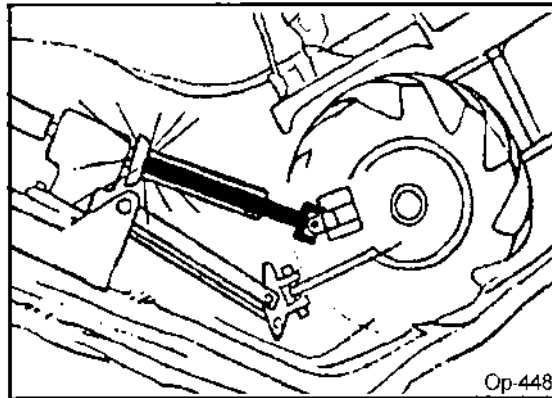

Damage resulting from over-collapse of the driveline's inner profile and its outer housing may allow the driveline to come loose from the Tractor which could cause bodily injury to the operator or bystanders and/or extensive damage to the Tractor or Implement

OPERATION

When confronted with an incline or ditch, do not approach from an angle which is perpendicular or straight on as damage to over collapse of the driveline may occur.

When crossing such terrain, the wings should be fully lowered for a lower center of gravity and added stability.

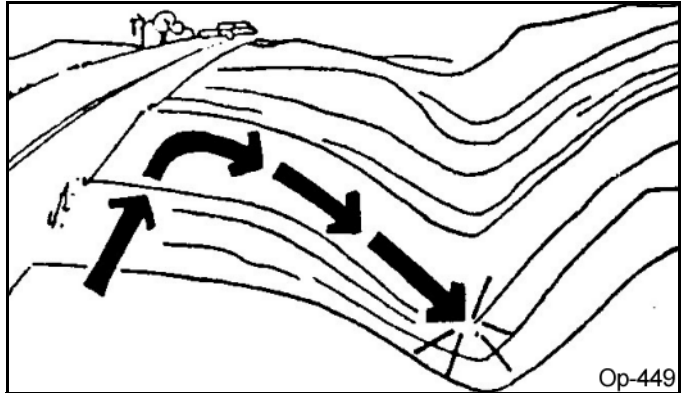

INCORRECT: DO NOT approach ditch straight on.

Inclines and ditches should be approached along a line which is at an angle as shown. This type of path will reduce the possibility of over-collapse of the driveline and resulting damage. If the gradient is so steep that such an approach increases the possibility of a tractor roll-over, select an alternate crossing path.

OPS-F-0050

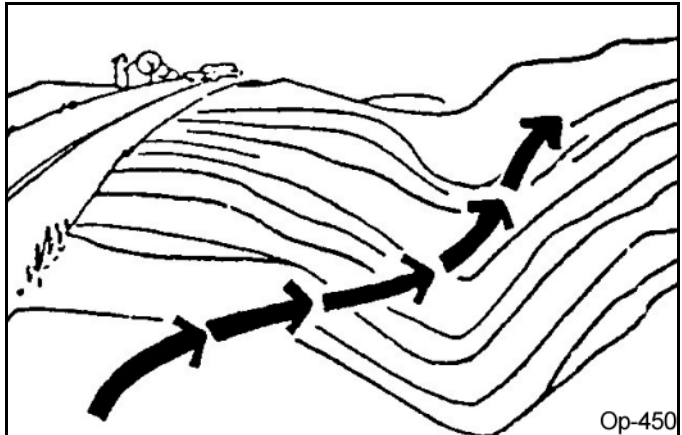

CORRECT: Approach ditch at an angle.

When operating the tractor and mower across slopes and inclines, through ditches, and other uneven terrain conditions, it is important to maintain sufficient deck to ground clearance. Blade contact with the ground may cause soil, rocks and other debris to be thrown out from under the mower resulting in possible injury and/or property damage. Ground contact also produces a severe shock load on the mower drive and to the mower blades resulting in possible damage and premature wear.

OPERATION

8. OPERATING THE TRACTOR AND IMPLEMENT

THE OPERATOR MUST COMPLETELY UNDERSTAND HOW TO OPERATE THE TRACTOR AND IMPLEMENT AND ALL CONTROLS BEFORE ATTEMPTING TO OPERATE. The operator must read and understand the Safety and Operation Sections of the implement and tractor operator's manuals. These manuals must be read and explained to any operator who cannot read. Never allow someone to operate the implement and tractor without complete operating instructions.

Before starting any operation, the operator must become familiar with the area to be worked in and any obstacles and hazards contained within to ensure safety to the operator, bystanders, and equipment. Special attention should be paid to foreign debris, rough terrain, steep slopes, and passersby and animals in the area.
OPS-U- 0015

Engage the PTO shaft at low engine speed and speed the engine up after blades are fully engaged. Never engage the PTO shaft at a high engine speed. This could cause damage to the PTO shaft as well as the Speed Increaser and Pump. Always operate PTO at the recommended RPM when mowing. This is necessary to maintain proper blade speed and to produce a clean cut.

Proper ground speed for cutting will depend upon the height, type, and density of material to be cut. Normally, ground speed will range from 2 to 5 mph. Tall dense material should be cut at low speed while thin medium height material can be cut at a faster ground speed.

Always run the Mower at the highest position which will enable you to obtain the desired cutting results. Allowing the blades to cut into the ground will cause wear and undue strain on the mower frame and mower components.

If you are mowing in conditions of heavy growth or rough ground where the blades cut into the ground and the tractor engine slows down, do not depress the clutch on the tractor to allow the engine to speed up and engage the clutch again. This procedure exerts tremendous strain on Mower components. Always disengage the PTO and move forward or backwards until the machine is clear.

This mower is designed with free swinging blades. This feature reduces the amount of shock transmitted to other components. Always make sure the blades can swing freely.

Do not ride the clutch on the tractor. Mow in the appropriate gears to give the correct ground speed.

As often as possible, stop mowing when other people are passing by. Although the Mower is shielded to prevent objects from being thrown out by the blades, no one shield device is 100% effective. The safest possible course is the only sensible approach to the problem of endangering a passerby. The operator has greater knowledge of the dangers of being around this Mower while it is operational than the person on the street.

WARNING

Extreme care should be taken when operating near loose objects such as gravel, rocks, wire, and other debris. Inspect the area before mowing. Foreign objects should be removed from the site to prevent machine damage and/or bodily injury or even death. Any objects that cannot be removed must be clearly marked and carefully avoided by the operator. Stop mowing immediately if blades strike a foreign object. Repair all damage and make certain rotor or blade carrier is balanced before resuming mowing. (SGM-05)



OPERATION

⚠️ WARNING

Many varied objects, such as wire, cable, rope, or chains, can become entangled in the operating parts of the mower head. These items could then swing outside the housing at greater velocities than the blades. Such a situation is extremely hazardous and could result in serious injury or even death. Inspect the cutting area for such objects before mowing. Remove any like object from the site. Never allow the cutting blades to contact such items.

(SGM-06)

8.1 Foreign Debris Hazard

Before mowing, inspect the area to make sure there are no foreign objects that the mower blades could hit or become entangled with. Remove all foreign objects and debris. If objects are too big to remove, mark them clearly and be sure to prevent the mower blades from contacting them. *OPS-F-0051*



If you hit a solid object or foreign debris, stop the mower and tractor at once. Immediately idle the engine speed and disengage the PTO. Wait for all mower motion to stop, then raise the mower and move the tractor and mower off the object. Inspect the area and remove or mark the location of the debris. Inspect the condition of the mower and make any needed repairs immediately. Make sure the blades are not damaged and the cuttershafts are balanced before resuming operation. *OPS-F-0052*



Always wear your seat belt securely fastened and only operate the tractor and mower with the ROPS in the raised position. If the tractor or mower hits a tree stump, rock, or bump, a sudden movement could throw you off of the seat and under the tractor and/or mower. The seat belt is your best protection from falling off the tractor and the ROPS provides protection from being crushed during a tractor roll-over.

OPERATION

8.2 Bystander/Passersby Precautions

If a bystander comes within 100 yards of the tractor while the mower is being operated, stop the tractor at once, idle the engine and disengage the PTO. Do not engage the PTO again until all bystanders are well past the 100 yard distance.



Flail Mowers are capable under adverse conditions of throwing objects for great distances (100 yards or more) and causing serious injury or death. Follow safety messages carefully.



STOP MOWING IF PASSERSBY ARE WITHIN 100 YARDS UNLESS:

- Front and Rear Deflectors, Chain Guards, or Bands are installed and in good, workable condition;
- Mower sections or Wings are running close to and parallel to the ground without exposed Blades;
- Passerby are outside the existing thrown-object zone;-All areas have been thoroughly inspected and all foreign material such as rocks, cans, glass, and general debris has been removed.

NOTE: Where there are grass and weeds high enough to hide debris that could be struck by the blades, the area should be: inspected and large debris removed, mowed at an intermediate height, inspected, closely with any remaining debris being removed, and mowed again at desired final height. (This will also reduce power required to mow, reduce wear and tear on the Mower drivetrain, spread cut material better, eliminate streaking, and make the final cut more uniform.) (SFL-6)

8.3 Engaging the Power to Take Off (PTO)

Before engaging the PTO, make certain that the area is clear of bystanders and passersby. The mower wings must be completely lowered and the deck positioned at a safe mowing height. NEVER engage the PTO with the mower wings in the raised position.

Set the tractor engine speed at approximately 1,000 PTO speed before engaging the PTO. Shift the PTO control to the on position, and slowly increase the engine speed until the PTO is operating at 540 PTO speed. If you hear unusual noises or see or feel abnormal vibrations, disengage the PTO immediately. Inspect the mower to determine the cause of the noise or vibration and repair the abnormality.



Do not let the Blades turn when the Mower Deck is raised for any reason, including clearance or for turning. Raising the Mower deck exposes the Cutting Blades which creates a potentially serious hazard and could cause serious injury or even death from objects thrown from the Blades. (SRM-07)



Do not put hands or feet under mower decks. Blade Contact can result in serious injury or even death. Stay away until all motion has stopped and the decks are securely blocked up. (SGM-09)

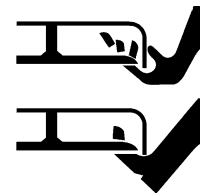

OPERATION

8.4 PTO RPM and Ground Speed

Ground speed for mowing will depend upon the height, type, and density of vegetation to be cut. Recommended speed for efficient mower performance is between 2 and 5 mph. Mower is designed to mow effectively when a cuttershaft speed of 2100 RPM is maintained. Operate the mower at its rated PTO speed of 540 to maintain blade speed for a clean cut. Refer to the tractor operator's manual or the tractor instrument panel for the engine speed and gear to provide the required PTO and desired ground speed. Make sure that the mower is operating at its full rated speed before entering the vegetation to be cut. If it becomes necessary to temporarily regulate engine speed, increase or decrease the throttle gradually.

If the cuttershaft slows down because of heavy cutting, the tractor ground speed must be reduced. If not, the grass may wind around the shaft rather than being discharged properly. The extra load will increase the pressure required to turn the cuttershaft and raise the oil temperature. Should the oil temperature go above 180 degrees F, damage to the seals, bushings or bearings may result. **GIVE THE UNIT TIME TO CUT.** When working in heavy growth, reduce the tractor ground speed.

Ground speed is achieved by transmission gear selection and not by the engine operating speed. The operator may be required to experiment with several gear range combinations to determine the best gear and range which provides the most ideal performance from the mower and most efficient tractor operation. As the severity of cutting conditions increase, the ground speed should be decreased by selecting a lower gear to maintain the proper operating PTO speed.



Do not exceed the rated PTO speed for the Implement. Excessive PTO speeds can cause Implement driveline or blade failures resulting in serious injury or death. (SG-26)



Mow at the speed that you can safely operate and control the tractor and mower. The correct mowing speed depends on terrain condition and grass type, density, and height of cut. Normal ground speed range is from 2 to 5 mph(3-8 kph). Use slow mowing speeds when operating on or near steep slopes, ditches, drop-offs, overhead obstructions, power lines, or when debris and foreign objects are to be avoided. (SGM-07)

9. Operating the Mower

Only operate the mower from the tractor operator's seat with the seatbelt securely fastened on a ROPS or cab equipped tractor. The mower is designed for cutting grass and small weeds. Sharp blades will produce a cleaner cut and require less power. Travel at a speed that allows the mower sufficient time to cut through the vegetation and maintain the PTO operating speed to prevent overloading the mower and tractor. Choose a driving pattern that provides the maximum pass length and minimizes turning. Stay alert and watch for trees, low hanging limbs, power lines, and other overhead obstacles and solid ground objects while you are operating.

Under some conditions, tractor tires may roll vegetation down preventing a cut at the same height as the surrounding area. To minimize this problem, reduce the tractor ground speed while maintaining the operating speed of the mower. A slower ground speed allows grasses to partially rebound and be cut. Reversing the direction of travel may also help produce a cleaner cut in these conditions.

Avoid mowing in the reverse direction. If the mower must be backed to access an area to cut, make sure there are no persons or other foreign debris behind the mower before mowing in reverse. When mowing in reverse, operate the tractor and mower at a reduced ground speed to ensure control of the tractor and mower is maintained.

OPERATION

WARNING

Do not mow with two machines in the same area except with Cab tractors with the windows closed. (SGM-11)

WARNING

Mow only in conditions where you have clear visibility in daylight or with adequate artificial lighting. Never mow in darkness or foggy conditions where you cannot clearly see at least 100 yards(90 m) in front and to the sides of the tractor and mower. Make sure that you can clearly see and identify passersby, steep slopes, ditches, drop-offs, overhead obstructions, power lines, debris and foreign objects. If you are unable to clearly see these type of items discontinue mowing. (SGM-1)

WARNING

Avoid mowing in reverse direction when possible. Check to make sure there are no persons behind the mower and use extreme care when mowing in reverse. Mow only at a slow ground speed where you can safely operate and control the tractor and mower. Never mow an area that you have not inspected and removed debris or foreign material. (SGM-08)

WARNING

Follow these guidelines to reduce the risk of equipment and grass fires while operating, servicing, and repairing the Mower and Tractor:

-Equip the Tractor with a fire extinguisher in an accesible location.



- Do Not operate the Mower on a Tractor with an underframe exhaust.
 - Do Not smoke or have an open flame near the Mower and Tractor.
 - Do Not drive into burning debris or freshly burnt areas.
 - Ensure slip clutches are properly adjusted to prevent excessive slippage and plate heating.
 - Never allow clippings or debris to collect near drivelines, slip clutches, and gearboxes.
- Periodically shut down the Tractor and Mower and clean clippings and collected debris from the mower deck. (SGM-12)

OPERATION

9.1 Shutting Down the Implement

To shut down attached mower head, first bring the tractor to a complete stop. Decrease engine RPM to idle then disengage cutterhead. The mower head will come to a complete stop within a suitable amount of time. Do not engage or disengage the cutterheads at a high RPM unless there is an emergency situation.

Park the tractor on a level surface, place the transmission in park or neutral and apply the parking brake, lower the attached implement to the ground, shut down the engine, remove the key, and wait for all motion to come to a complete stop before exiting the tractor. *OPS-U-0016*



10. DISCONNECTING THE MOWER FROM THE TRACTOR



Always shut the Tractor completely down, place the transmission in park, and set the parking brake before you or anyone else attempts to connect or disconnect the Implement and Tractor hitches. (S3PT-15)

OPERATION

OPERATION

To disconnect the rear mower, first extend the tractor 3-point hitch top link to remove tension on the top link hitch pin. When the pin is loose and easy to rotate, remove the pin from the mower. Next remove both lower hitch pins. *OPS-F-0055*



After disconnecting the 3 lift points, remove the mower driveline from the tractor PTO shaft. Lay the driveline down carefully to avoid damaging the driveline or its shield. Do not let the driveline fall into mud or dirt, which can contaminate the bearing and shorten the life of the driveline. *OPS-F-0056*

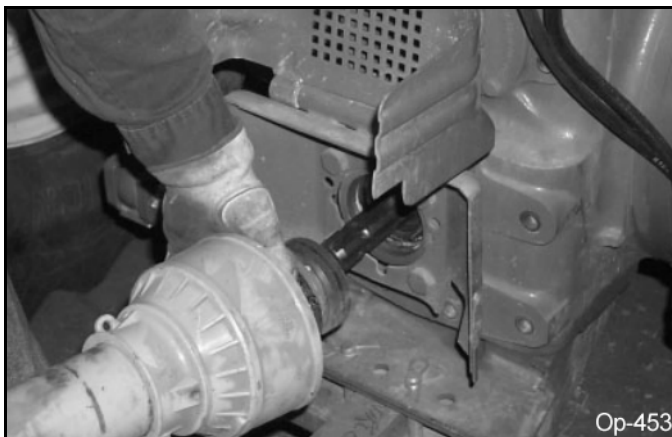

Before disconnecting the mower, the PTO must be disengaged and all motion at a complete stop. Move the mower to a level storage location and lower both wings to the ground. If the mower will be stored with the sections in the raised position, be sure that the locks are engaged. If the mower is not resting securely on the ground, block the mower up securely before attempting to disconnect it from the tractor. Use extreme care to keep feet and hands from under the mower and clear of any pinch points.

OPERATION

11. MOWER STORAGE

It is recommended that the mower be stored lowered to ground level. If the mower is stored in the raised position, select a level area and ensure the wing is locked to prevent unexpected falling BEFORE disconnecting the mower 3-point hitch and hydraulics from the tractor.

Properly preparing and storing the mower at the end of the season is critical to maintaining its appearance and to help ensure years of dependable service. The following are suggested storage procedures:

1. Thoroughly clean all debris off the mower to prevent damage from rotting grass and standing water.
2. Lubricate all mower grease points and fill hydraulic tank oil level as detailed in the maintenance section.
3. Tighten all bolts and pins to the recommended torque.
4. Check the mower for worn and damaged parts. Perform repairs and make replacements immediately so that the mower will be ready for use at the start of the next season.
5. Store the mower in a clean, dry place with the mower housing resting securely on blocks or at ground level.
6. Keep the driveline yoke from sitting in water, dirt and other contaminants.
7. Use spray touch-up enamel where necessary to prevent rust and maintain the appearance of the mower.

It is critical that the driveline clutch slip when an obstacle or heavy load is encountered to avoid mower and/or tractor damage. If the mower sits outside for an extended period of time or is exposed to rain and/or humid air, the clutch lining plates must be inspected to ensure they are not frozen together from rust or corrosion. If the mower has been exposed to such conditions, at the start of each mowing season, and any time it is suspected that the slip clutch plates may be frozen together, readjust the slip clutch as detailed in Clutch Maintenance section of this manual.



Never allow children to play on or around Tractor or Implement. Children can slip or fall off the Equipment and be injured or killed. Children can cause the Implement to shift or fall crushing themselves or others. (SG-25)

12. TRANSPORTING THE TRACTOR AND IMPLEMENT

Inherent hazards of operating the tractor and implement and the possibility of accidents are not left behind when you finish working in an area. Therefore, the operator must employ good judgement and safe operation practices when transporting the tractor and implement between locations. By using good judgement and following safe transport procedures, the possibility of accidents while moving between locations can be substantially minimized. OPS-U-0017



Never allow children or other persons to ride on the Tractor or Implement. Falling off can result in serious injury or death. (SG-10)



OPERATION

OPERATION

Before transporting the tractor and mower, idle the tractor engine, disengage the PTO and wait for all mower moving parts to come to a complete stop. Raise the mower section and ensure transport lock is engaged. *OPS-F-0057*

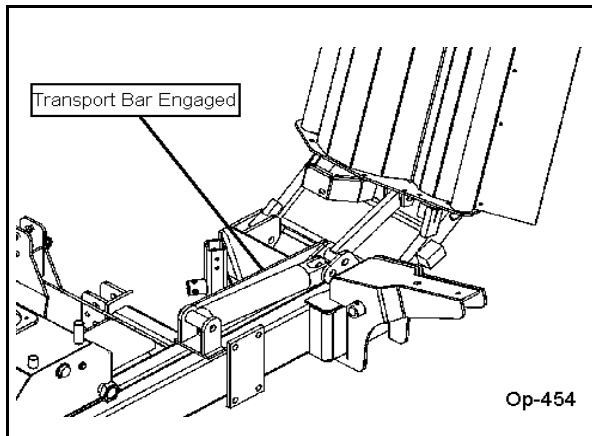

Before transporting the tractor on a public roadway or boarding a trailer for transport, the tractor brake pedals should be locked together. Locking the pedals ensures that both wheels brake simultaneously while stopping, especially when making an emergency stop.

Use extreme caution and avoid hard applications of the tractor brakes when towing heavy loads at road speeds. Never tow the implement at speeds greater than 20 MPH (25 kph). *OPS-U-0018*

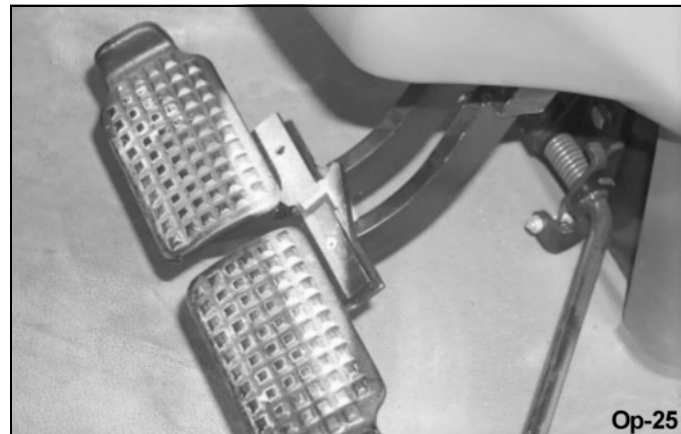

If the tractor's hydraulic pump is not independent of the tractor PTO, or if the tractor PTO has to be run to have hydraulic power, disconnect the mower driveline from the tractor PTO output shaft. Secure the driveline to the mower deck to prevent driveline damage or loss during transport.

OPERATION

12.1 Transporting on Public Roadways

Extreme caution should be used when transporting the tractor and implement on public roadways. The tractor must be equipped with all required safety warning features including a SMV emblem and flashing warning lights to alert drivers of the tractor's presence. Remember that roadways are primarily designed for automotive drivers and most drivers will not be looking out for you, therefore, you must look out for them. Check your side view mirrors frequently and remember that vehicles will approach quickly because of the tractor's slower speed. Be extremely cautious when the piece of equipment that you are towing is wider than the tractor tire width and/or extends beyond your lane of the road.

Make sure that a proper size safety tow chain is secured between the tractor and implement before entering a public road. OPS-U- 0019



Only tow the Implement behind a properly sized and equipped Tractor which exceeds the weight of the Implement by at least 20%. DO NOT tow the Implement behind a truck or other type of vehicle. Never tow the Implement and another Implement connected in tandem. Never tow the Implement at speeds over 20 MPH. (STI-06)



Never allow children or other persons to ride on the Tractor or Implement. Falling off can result in serious injury or death. (SG-10)



Make certain that the "Slow Moving Vehicle" (SMV) sign is installed in such a way as to be clearly visible and legible. When transporting the Equipment use the Tractor flashing warning lights and follow all local traffic regulations. (SG-6)

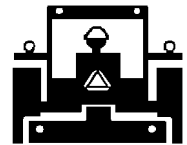

The SMV (Slow-Moving Vehicle) emblem is universal symbol used to alert drivers of the presence of equipment traveling on roadways at a slow speed. SMV signs are a triangular bright orange with reflective red trim for both easy day and night visibility. Make sure the SMV sign is clean and visible from the rear of the unit before transporting the tractor and implement on a public roadway. Replace the SMV emblem if faded, damaged, or no longer reflective. OPS-U- 0020



OPERATION

Make sure that all tractor flashing warning lights, headlights, and brake/tail lights are functioning properly before proceeding onto public roads. While newer model tractors have plenty of lighting to provide warning signals and operating lighting, most older models are only equipped with operating lights. Consult an authorized tractor dealer for lighting kits and modifications available to upgrade the lighting on older tractor models. *OPS-U- 0021*



When operating on public roads, have consideration for other road users. Pull to the side of the road occasionally to allow all following traffic to pass. Do not exceed the legal speed limit set in your country for agricultural tractors. Always stay alert when transporting the tractor and implement on public roads. Use caution and reduce speed if other vehicles or pedestrians are in the area. *OPS-U- 0022*



Reduce speed before turning or applying the brakes. Ensure that both brake pedals are locked together when operating on public roads. *OPS-U- 0023*

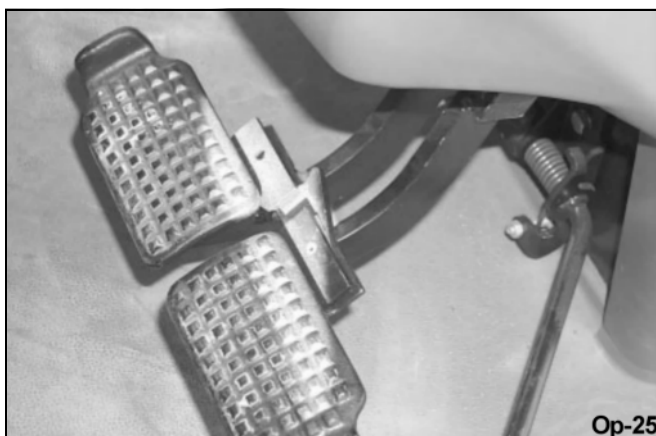

OPERATION

12.2 Hauling the Tractor and Implement

Before transporting a loaded tractor and implement, measure the height and width dimensions and gross weight of the complete loaded unit. Ensure that the load will be in compliance with the legal limits set for the areas that will be traveled through. *OPS-U- 0024*



Use adequately sized and rated trailers and equipment to transport the tractor and implement. Consult an authorized dealer to determine the proper equipment required. Using adequately sized chains, heavy duty straps, cables and/or binders, securely tie down both the front and rear of the tractor utilizing the proper tie down locations as specified by the tractor manufacturer. *OPS-U- 0025*



Arrange the chains so that when tightened, the chains are pulling downward and against themselves. Carefully tighten the securing chains or other fasteners using boomers or binders to apply maximum tension. Use extreme care when attaching and removing the securing devices as the extreme tension involved when released has the potential to inflict serious injury.

While hauling the tractor and implement, make occasional stops to check that the tractor and implement have not moved or shifted and that the securing chains have maintained tension. If during transport a hard braking, sharp turning, or swerving action was performed, stop at the next safe location to inspect the security of the load. *OPS-U- 0026*



OPERATION

13. TROUBLESHOOTING GUIDE

TROUBLE	POSSIBLE CAUSE	POSSIBLE REMEDY
Mower will not rotate	<ol style="list-style-type: none"> 1. Inline fuse blown. 2. Safety switch not making contact. 3. Broken drive belts. 4. On/Off switch bad. 5. Insufficient voltage through solenoid. 6. Solenoid spool will not shift completely. 	<p>Replace Fuse. Adjust or replace safety switch. Replace belts. Replace On/Off switch. Check oil and wires.</p> <p>Clean or replace solenoid cartridge.</p>
Mower will not stop	<ol style="list-style-type: none"> 1. Solenoid spool will not shift. 	<p>Clean or replace solenoid cartridge.</p>
Intermittent mowing power or low cuttershaft speed.	<ol style="list-style-type: none"> 1. Safety switch maladjustment. 2. Electrical problem. 3. Bad solenoid. 	<p>Adjust safety switch.</p> <p>Trace electrical circuit for short. Replace solenoid coil.</p>
Insufficient cutting power	<ol style="list-style-type: none"> 1. Drive belts slipping. 2. Bound shaft. 3. Relief valve setting to low. 4. Solenoid spool will not shift completely. 5. Worn pump or motor. 	<p>Readjust belt tension and check idler springs. Free the shaft. Adjust relief valve. Replace valve cartridge.</p> <p>Replace or rebuild.</p>
Hydraulic oil overheating- mower free to rotate	<ol style="list-style-type: none"> 1. Low fluid level. 2. Relief valve setting too high. 3. Obstruction in power circuit- Extra or will-fit parts. 	<p>Fill to proper level.</p> <p>Adjust relief valve. Remove obstruction & extra items which are not standard.</p>
Pump making loud noise	<ol style="list-style-type: none"> 1. Low oil level. 2. Vacuum in reservoir. 3. Clogged oil filter. 4. Worn pump. 	<p>Add hydraulic fluid. Clean or replace breather valve. Replace filter. Replace or rebuild.</p>

OPERATION

TROUBLESHOOTING GUIDE (Cont'd)

TROUBLE	POSSIBLE CAUSE	POSSIBLE REMEDY
Mower will not raise or raises slowly.	<ol style="list-style-type: none">1. Relief valve setting too low.2. Worn cylinder.3. Worn control valve.	<p>Adjust relief valve.</p> <p>Replace or rebuild. Replace valve section. See tractor manual.</p>
System noisy.	<ol style="list-style-type: none">1. Air in system due to low oil level.2. Loose suction line.3. Clogged suction filter.4. Internal pump or motor damage.	<p>Fill in reservoir to sight glass.</p> <p>Tighten fittings. Replace filter element. Disassemble, inspect and repair.</p>
Sluggish response to acceleration or deceleration	<ol style="list-style-type: none">1. Air in system.2. Internal pump or motor wear or damage.	<p>Replace fuse. Adjust or replace safety switch. Replace belts. Disassemble, inspect and repair.</p>
Motor turns while unloaded, but slows down or stops when load is applied.	<ol style="list-style-type: none">1. Scored back plate.2. Scored or worn piston shoes.3. Low relief valve pressure.	<p>Remove backplate and examine surface condition of flat area; if scored, replace backplate. Do not Lap. Disassemble motor examine, condition of shoes on pistons; replace pistons as a complete set if necessary. Do not Lap. Check relief valve for proper pressure setting; adjust or replace relief valve.</p>
Motor will not turn.	Severely scored backplate.	Disassemble motor completely. Inspect all parts, clean all parts, replace all worn parts and flush hydraulic system.

OPERATION

OPERATION

TROUBLE	POSSIBLE CAUSE	POSSIBLE REMEDY
Excessive case drain	Excessive internal wear	Disassemble motor, inspect parts and replace as necessary. Case drain flow should not exceed 1.5 GPM at full pressure.
Mower heads scalping.	<ol style="list-style-type: none">1. Center unit top link out of adjustment.2. Cutting height set to low.	<p>Level front unit so that skid shoes are level with ground. Raise cutting height.</p>

MAINTENANCE SECTION

Maintenance Section 5-1

MAINTENANCE

DAILY CHECKS

1. Lubricate the VERSA PRO at the specified intervals as outlined in the lubrication diagram. All mower grease fittings are equipped with lubricaps which snap over the grease fittings to prevent dirt from entering the fittings. Remove the cap and wipe the fitting before greasing. Wipe the outlet of the grease gun then grease the bearing. When finished, place the cap over the fitting and wipe any excess grease from around the cap. In extremely dusty conditions, it is desirable to lubricate more often than every 8 hours. Grease PTO shaft as outlined on the diagram located on PTO shaft shield. The idler pulleys are equipped with a sealed ball bearing and require no further lubrication. Caster wheel bearings should be repacked at the end of each mowing season and checked before the start of the next season. The gearbox is shipped with the proper amount of SAE No. 90 extreme pressure lubricant. Maintain the level of this oil at the lower 1/8" pipe plug on the gearbox cover. LUBRICATE MOWER BEFORE INITIAL USE.

2. Before each day's use, follow this procedure:

Visually check the unit, and make certain all items are properly tightened.

NOTE: *Cutter unit belt tension is maintained by a spring-loaded idler pulley.*

Check the reservoir fluid level with the cutter units in the transport position. The oil level should be even with the sight glass located on the reservoir. Before removing filler cap, wipe the top of the reservoir to prevent dirt from entering the tank.

NOTE: *If the reservoir needs oil, a leak exists somewhere in the system. Repair the leak before using the unit.*

Check the cuttershaft to make certain it is fully knifed. Replace any missing knives or cotter pins, then run the unit at full speed to check for vibrations. Do not operate the unit in an out-of-balance condition.



Before doing maintenance, turn off power, and securely block up mower.

MAINTENANCE

MAINTENANCE

LUBRICATION INFORMATION

Before operating your Mower, make sure it is properly lubricated and thoroughly inspected. Only a minimum of time and effort is required to regularly lubricate and maintain this machine to provide long life and trouble free operation.



Always disengage the PTO before raising the mower for transporting or making adjustments.

Do not let excess grease collect on or around parts, particularly when operating in sandy areas. The illustrations below shows lubrication points. All points should be lubricated daily under normal operating conditions. Severe or unusual conditions may require more frequent lubrication. **Mnt-FL-0077.**

Use an SAE multi-purpose, lithium-type grease for all location shown. Be sure to clean the fitting thoroughly before using grease gun. Daily lubrication of the wing driveline slip joint is necessary. Failure to maintain proper lubrication will result in damage to U-joints, gearbox, and / or driveshaft.

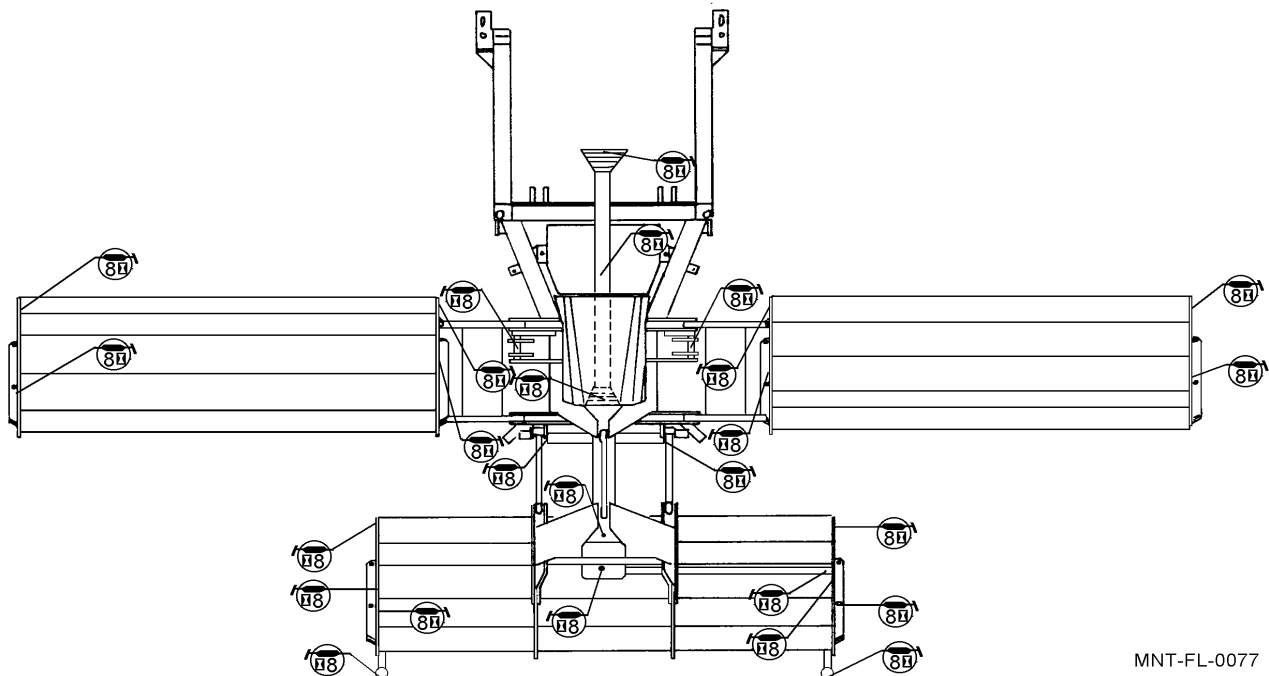

MNT-FL-0077

MAINTENANCE

CHANGING HYDRAULIC SYSTEM FILTER

A large capacity filter is located on top of the hydraulic oil reservoir. **Mnt-FL-0078**. The filter will trap particles which are .001 inch or larger. The filter needs to be changed after the first 10 hours of operation and every 200 hours or every 12 months thereafter.

MAINTENANCE

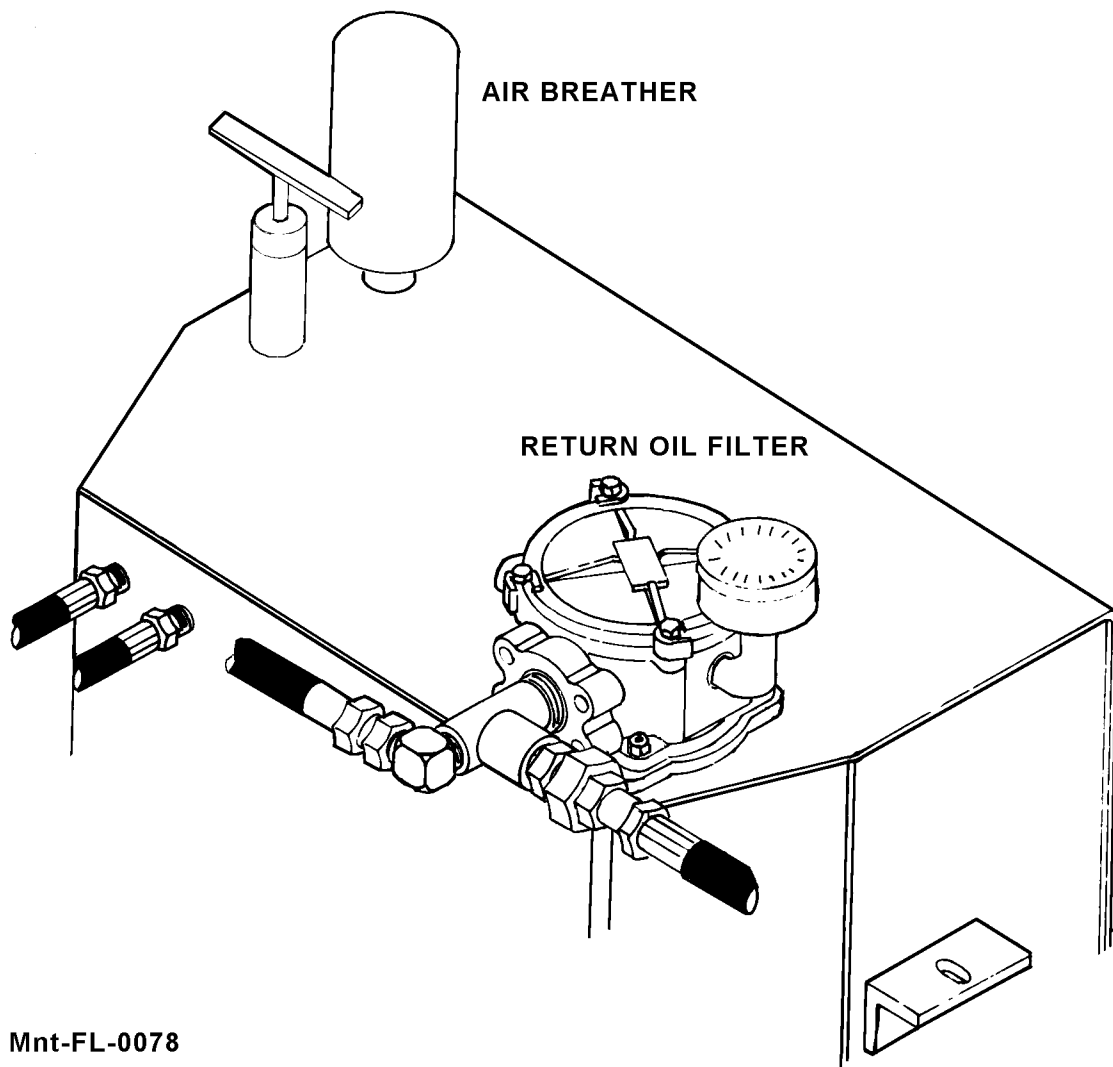

MAINTENANCE

CHANGING HYDRAULIC SYSTEM FILTER (Cont'd)

1. Clean the filter cover to prevent dirt from entering tank.
2. Loosen the four bolts on the filter cover. **Mnt-FL-0004.** Remove one bolt from the filter to aid in removing the filter cover. **Mnt-FL-0005.**

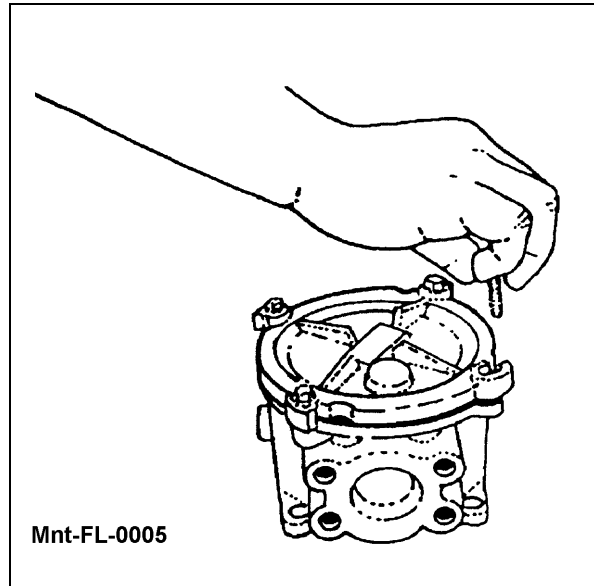
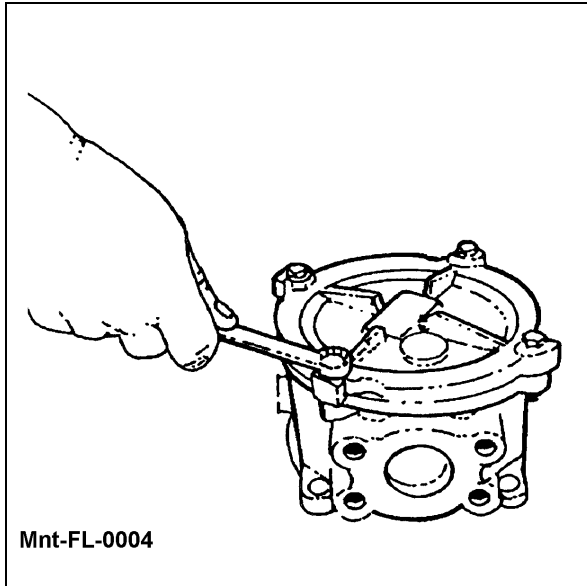

3. Push the filter cover down and slowly twist the filter cover off. **Mnt-FL-0006.**
4. Remove filter spring. **Mnt-FL-0007.**

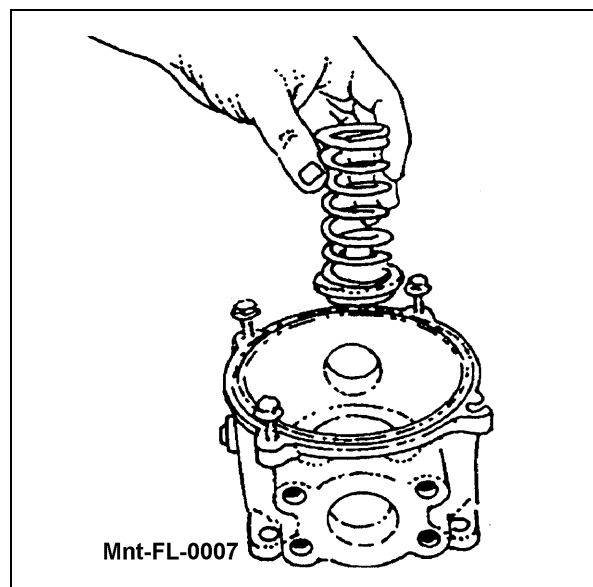
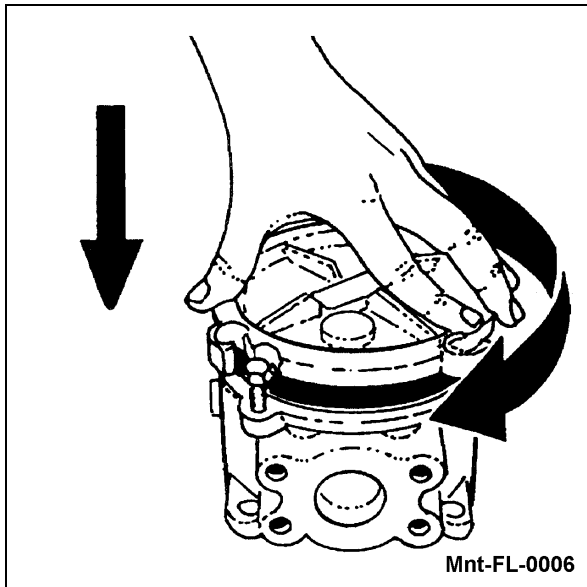

MAINTENANCE

MAINTENANCE

CHANGING HYDRAULIC SYSTEM FILTER (Cont'd)

5. Remove filter. Inspect material trapped by the filter. It can indicate parts wear in the system. **Mnt-FL-0008.**

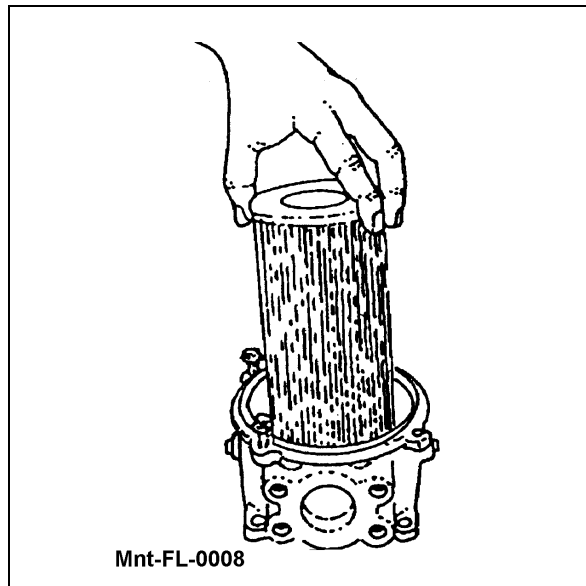

6. Install the new filter.
7. Reinstall filter spring and filter cover. Replace the one bolt which had previously been removed. Tighten all bolts in an even manner. **Mnt-FL-0079.**

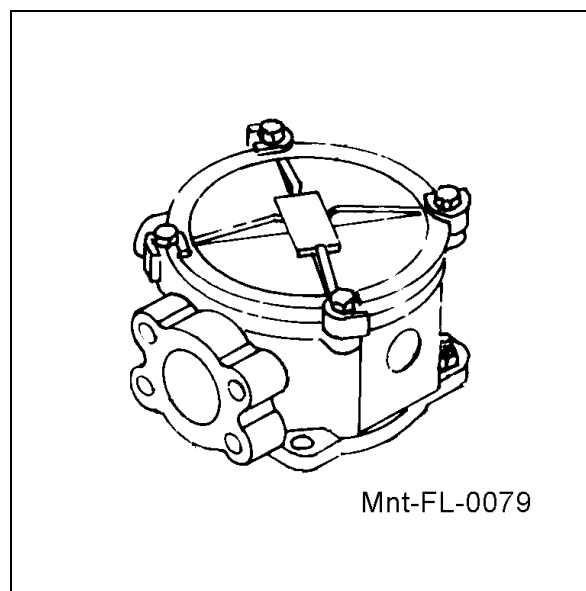

MAINTENANCE

GENERAL

Mowing is accomplished by a series of knives which rotate at high speed on a shaft. The shaft is driven by a hydraulic motor through a set of drive belts. Belt tension is maintained by a spring-loaded idler pulley.

The cutter unit is mounted to the lift frame by two mounting pins and held in place by a hydraulic cylinder. This cylinder is used to tilt the cutter unit to allow mowing on an angle and tilting to the vertical position for transporting.

The cutter unit rides on a large roller assembly. The position of this roller is adjustable and will determine the cutting height of the knives.

REPLACING CUTTER UNIT DRIVE BELTS

Image Mnt-FL-0020

1. Place unit on ground or support securely.
2. Remove belt guard.
3. Remove idler arm spring.
4. Remove extension shaft housing mounting bracket front bolt and loosen rear bolt.
5. Remove motor mounting bracket front bolt and loosen rear bolt.
6. Pivot motor-mounting bracket assembly. Remove old belts and install new ones.
7. Reinstall front mounting bolt then secure motor mounting bracket to unit.
8. Reinstall idler arm spring and belt guard.

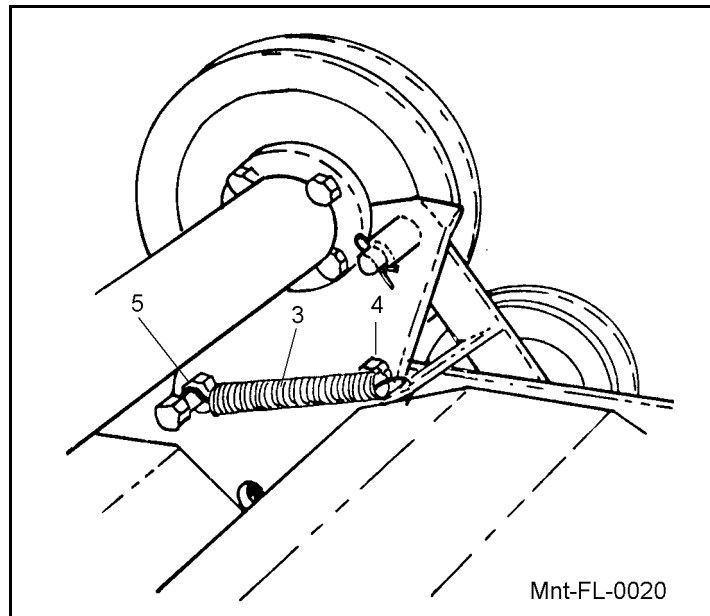

ADJUSTING CUTTING HEIGHT

Image Mnt-FL-0064

1. Lower cutter unit to ground.
2. Place lifting device (scissors jack, hydraulic jack) under center of cutter housing.
3. Remove hex nuts, washers and carriage bolts from bracket at each end of roller. Make certain that roller bracket is free to move once the fasteners are removed. A stuck roller could drop suddenly and cause an injury.
4. Use lifting device to reposition cutter housing to desired cutting height. Align bracket holes with cutterhousing holes, then reinstall fasteners.
5. Lower cutter unit to ground; then remove lifting device

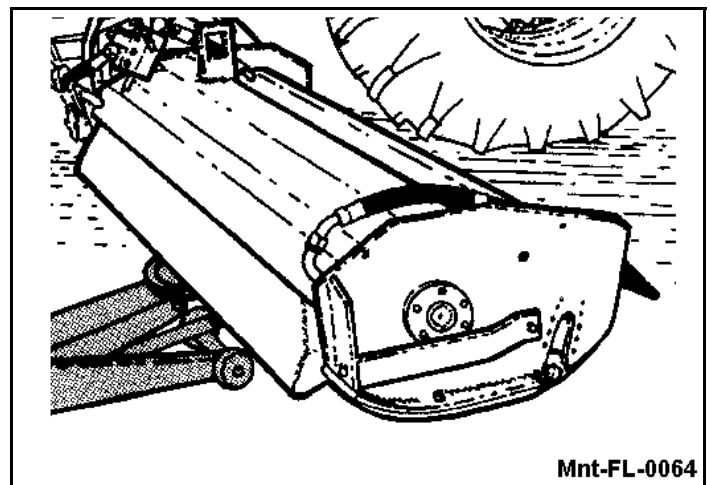

MAINTENANCE

ROLLER BEARING REPLACEMENT

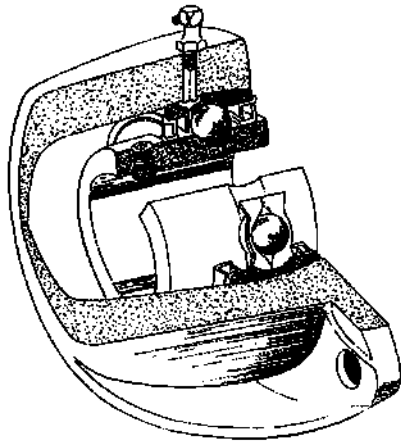

DETAIL OF
ROLLER BEARING

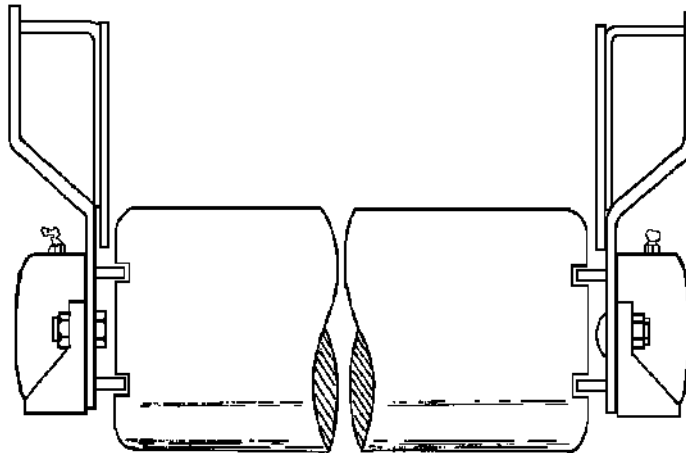

Mnt-FL-0056

1. Remove roller and both bearing and bracket assemblies from mower. Lift the mower only high enough to remove the roller assembly.

CAUTION

Securely support mower while removing and installing roller assembly.

If installing a roller with preassembled bearing and bracket assemblies, remove the old roller, proceed to step 11.

2. Slide bearing and bracket assemblies off each end of roller.
If replacing with new bearing and bracket assemblies, proceed to step 9.
3. Remove roller bearing and housing assembly attaching hardware. Remove assembly from bracket. Inspect seal between assembly and bracket for brittleness, cracks, wear and tear. Replace if necessary.
If replacing with new roller bearing and housing assemblies, proceed to step 8.
4. Remove grease fitting from the top of bearing housing.
5. Remove bearing from housing. By rotating Bearing 90 degree sideways and line up with notches in Bearing Housing; then pull out
6. Install new bearing into housing. Bearing must be installed with grease hole in bearing aligned with grease fitting hole in housing.
7. Reinstall grease fitting to housing. Grease fitting must be tight and seated in grease hole in bearing to prevent bearing from rotating in housing.
8. Attach roller bearing and housing assembly to bracket with seal between housing and bracket.
9. Slide bearing and bracket assemblies on each end of roller.
10. Check bearing for proper installation in housing by gently rocking bearing and bracket assembly in end of roller. Play should be slight to none at all.
11. Install roller and bearing and bracket assemblies on mower.
12. Lubricate roller bearing until lubricant can be seen coming out between roller and bearing housing.

MAINTENANCE

CUTTERSHAFT BEARING REPLACEMENT

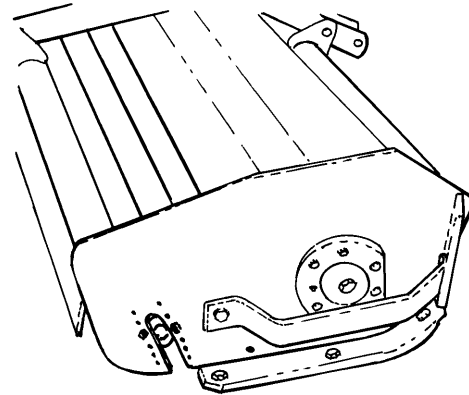

Mnt-FL-0021

OUTBOARD BEARING. (Mnt-FL-0021)

1. Lift cutter unit to maximum horizontal height; then securely support ends of cutterhousing.
2. Remove enough knives to place a floor jack under center of cutterhousing.
3. Securely support cuttershaft.

NOTE: *The cuttershaft must remain supported while changing bearings.*

4. Remove outboard fender.
5. Remove fasteners securing bearing and housing assembly to cutterhousing, then remove bearing and housing assembly.

NOTE: *There are two tapped holes in the housing which can be used to pull bearing and housing assembly out by using special tool No. 701627.*

6. Using a jack to align parts, install bearing and housing assembly to cutter unit and make certain that bearing setscrew is located in keyway on cuttershaft. Grease bearing and install cap over fitting.

If only the outboard bearing and housing assembly is to be replaced, proceed as follows: Remove jack and check shaft rotation. Reinstall knives which were removed. Reinstall outboard fender. Remove supports, lower unit to ground and test unit.

If the inboard (drive) bearing is to be replaced, proceed to step 7.

MAINTENANCE

MAINTENANCE

CUTTERSHAFT BEARING REPLACEMENT (Cont'd)

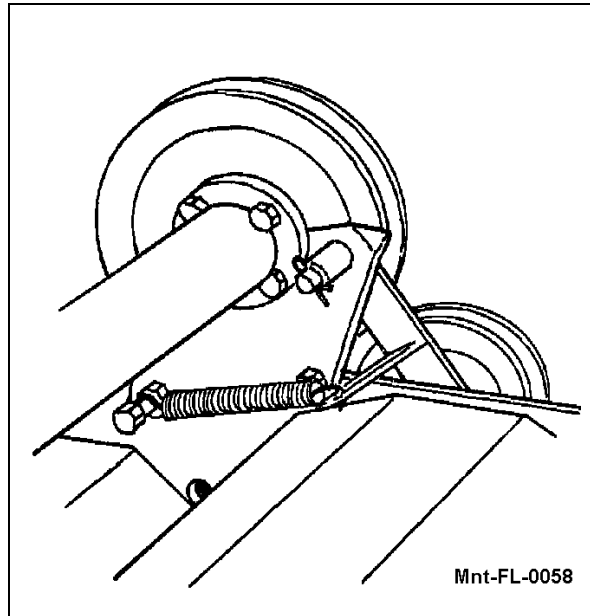
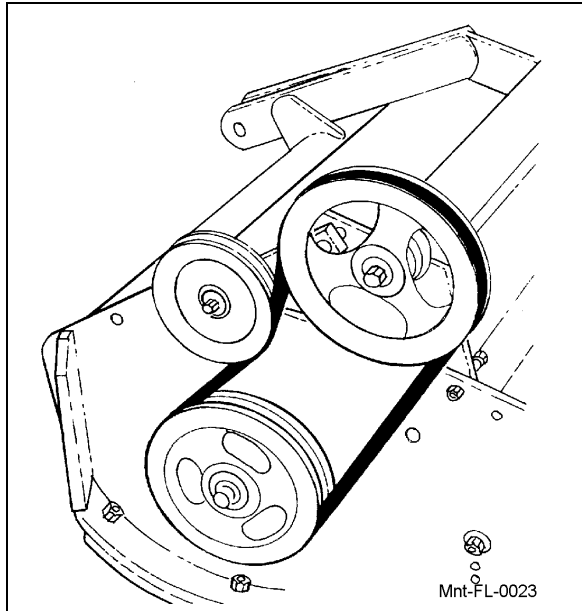

INBOARD (DRIVE) BEARING. (Mnt-FL-0023 & Mnt-FL-0058)

7. Remove Belt Guard.
8. Remove spring from idler arm.
9. Remove motor mounting bracket fasteners, at the cutterhousing. Pivot motor-mounting bracket assembly and remove drive belts.
10. Remove fasteners that secure pulley to cuttershaft. Remove pulley and key.
11. Remove fasteners securing inboard bearing and housing assembly to cutterhousing, then remove bearing and housing assembly. Refer to Illustration 11.

NOTE: *There are two tapped holes in the housing which can be used to pull bearing and housing assembly pull by using special tool No. 701627.*

12. Using a jack to align parts, install inboard bearing and housing assembly to cutter unit. Grease bearing and install cap over fitting.
13. Reinstall key and pulley. Secure with cuttershaft fasteners.
14. Remove jack and check shaft rotation. Reinstall knives which were removed.
15. Reinstall drive belts then secure motor mounting bracket to cutterhousing.
16. Reinstall idler arm spring.
17. Reinstall belt guard.
18. Remove supports, lower unit to ground and test unit. Reinstall outboard fender, if not already installed.

MAINTENANCE

CUTTERSHAFT REPLACEMENT

NOTE: It is recommended that cuttershaft bearing and housing assemblies be replaced when replacing cuttershaft.

1. Place unit on the ground or securely support at a convenient height.
2. Remove cuttershaft bearing and cutter assemblies as outlined in above. After removing both assemblies, the cuttershaft can be removed and a new one installed. It may be necessary to remove two sets of knives nearest the drive end of cuttershaft.
3. Install new bearing and housing assemblies as outlined in Image **Mnt-FL-0063**.

Changing to Forward or Reverse Rotation

WING MOWER

The hydraulic wing motors are dual rotation motors which means they will rotate in either direction depending on the inlet port used. An arrow on the flat surface of the motor housing at both ports indicate the direction of rotation. To change rotation, remove the four bolts that mount the manifold block to the motor. Remove the case drain hose at the motor, but leave it attached in present location at the manifold block. Leave all other plumbing as presently installed at the manifold block. Remove the two mounting bolts at the motor mounting plate and rotate the motor 180 degrees. This changes the present inlet port into the outlet port of the motor. Re-install manifold block but do not change the position. Install case drain hose.

CENTER MOWER

To change direction of cuttershaft rotation for the center mower, three parts are required. A belt guard, an outboard bearing plate and a idler pulley arm. (Consult parts book for these part numbers). Remove the cuttershaft and turn 180 deg. remove the gearbox cuttershaft drive pulley and outboard bearing plate, (using the proper bearing plate) mount the plate to opposite side of mower housing. Remove the four bolts that mounts the gearbox and rotate gearbox 180 deg. to new position. Install cuttershaft pulley, gearbox output pulley, idler arm pulley assembly and belt. **REPLACE EXISTING BELT GUARD WITH PROPER GUARD.**

Replacing Cutter Unit Knives

The cutter knives are attached to the cutter shaft with hardened pin and cotter pins. These pins are supplied with the knife kit. To remove existing knives, remove and discard these pins and install new knives using new pins. **Mnt-FL-0059.**

FOR FORWARD ROTATION: On the right wing and center unit, all knife pins must be installed with their heads facing away from the cuttershaft pulley. On the left wing, the heads of the knife pins must face the cuttershaft pulley.

FOR REVERSE ROTATION: On the right wing and center unit, all knife pins must be installed with their heads facing toward the cuttershaft pulley. On the left wing, the heads of the knife pins must face away from the cuttershaft pulley.

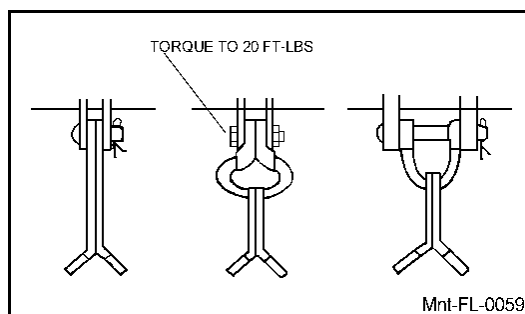

MAINTENANCE

HYDRAULICS

GENERAL

VERSA PRO hydraulic system consists of two circuits. The power circuit drives the cuttershaft. The control circuit lifts and tilts the cutter unit.

NOTE: It is important that pipe thread sealant be used on solid connections only; never on connections between swivel fittings or fittings with "O" rings and straight threads. Use pipe thread sealing compound. DO NOT substitute other types of sealant, such as teflon tape, paint, shellac, etc.

INITIAL START-UP PROCEDURES

Whenever the hydraulic system is drained in order to service a hydraulic component, the following start-up procedure should be completed.

1. Check all nuts and bolts to be sure they are tight and that all lock washers are fully compressed.
2. Check all hoses and hydraulic connections to be sure that they are tight.
3. Inspect all moving parts, and make certain that no wires or hoses will be caught or pinched when the tractor is in operation.
Secure all wires and hoses.
4. Thoroughly lubricate the VERSA PRO. Refer to **Mnt-FL-0077**, Section 5-3.
5. Change the hydraulic filter and fill the reservoir to the sight glass with new hydraulic oil. Refer to 2-5 for specifications.



Remove all objects from, and stand clear of, the front of the cutter unit. **DO NOT GET NEAR ROTATING KNIVES!**

6. Turn mowers off, then start tractor and run engine at low idle. Operate the cylinder, (turn cutter units on ONLY when mowers are fully lowered). Operate until the system is fully charged. Recheck the fluid level and add oil, if necessary. If undue noise continues after the system is fully charged, stop the unit and determine the cause.
7. After the hydraulic system is fully charged and functioning properly, switch the mowers on and increase the engine speed to run the 540 PTO speed. Maintain this speed for 5 minutes and look for any leaks or possible problems.

HYDRAULIC PUMPS

The pump unit assembly is made up of the oil reservoir, gearbox, and hydraulic pump. The pump is driven by the Tractor PTO through a drive shaft. Therefore, oil is being pumped whenever the PTO is engaged. When the mower is off, oil is directed to the reservoir by the solenoid motor control valve and does not flow to the cutter motor. Cooling is provided by patented in frame cooling tubes in the wing mowers.

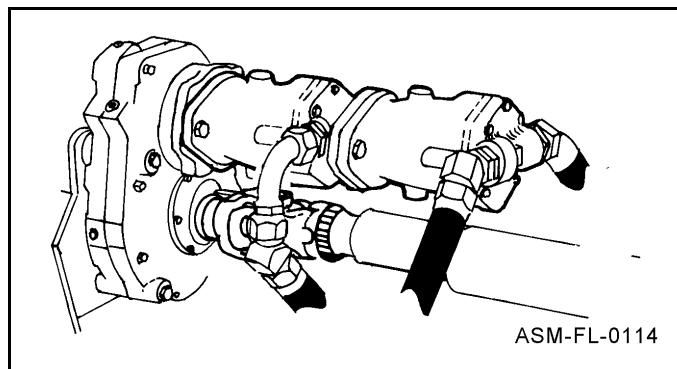

MAINTENANCE

REPLACING HYDRAULIC PUMPS

The pump unit for the power circuit is a piston fixed displacement pump (see specifications) and is PTO driven. It is mounted on the mainframe above the hydraulic reservoir. There is a separate pump for each wing. By following the hose routing, the operator can determine each wing mower's supply source. Each pump has a case drain to eliminate excessive fluid in the pump. All excess fluid in the pump is routed back to the reservoir through the case drain.

Replacing Outer Pump:

1. Remove the Pump Cover by unscrewing the wing nut which holds it in place.
2. Disconnect the outer Pump Suction Hose, Case Drain Hose, and the Pressure Hose.

NOTE: Clean spills at once. Cap all hoses immediately to prevent contamination of the hydraulic system.

3. Remove the two bolts which attach the outer pump to the inner pump flange.
4. Remove Pump. Lightly oil new "O" Ring and place on inner pump flange. Install the new Pump with the pump drain ports facing Hydraulic Tank.
5. Reinstall hydraulic hoses. Tighten hose fittings to their proper torque. Refer to Torque Chart.
6. Reinstall Pump Cover and tighten the four thumb screws securely.

Replacing Inner Pump:

7. To replace inner pump both pumps must be removed. Follow same procedure as for outer pump. BE SURE TO CAP ALL HOSES AND CLEAN OIL SPILLS AT ONCE.

NOTE: Clean spills at once. Cap all hoses immediately to prevent contamination of the hydraulic system.

8. Separate the inner pump from the outer pump and install new pump to inner pump following step 4 making sure both case drain ports are facing hydraulic reservoir.
9. Reinstall pumps to pump mounting bracket.
10. Reinstall all hoses. Tighten hose fittings to their proper torque refer to torque chart.
11. Reinstall all guards.

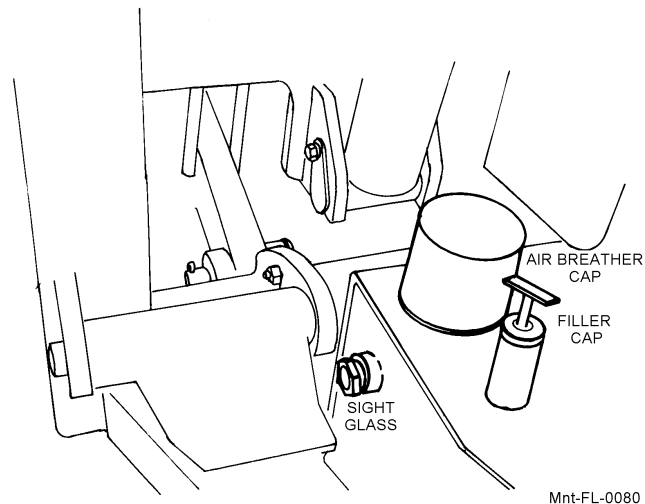

Mnt-FL-0080

MAINTENANCE

RESERVOIR

Mnt-FL-0080

The reservoir stores hydraulic system oil. The breather cap which is mounted on top of the reservoir prevents a pressure buildup or vacuum from occurring in the tank as oil level changes. There is also an oil filler cap which is used to fill the reservoir with oil. To help prevent dirt from entering the tank, clean the top of the reservoir before removing the cap. THE BREATHER CAP HOLDS APPROX 11 PSI PRESSURE IN TANK. REMOVE FILLER CAP SLOWLY

The oil level sight glass is located on the side of the reservoir. The oil level should be even with the sight glass and checked with the cutter unit in the transport position. The oil temperature should not exceed 180 degrees F.

The oil return hoses are connected to the hydraulic filter on top of the reservoir. Oil is returned from cutter unit cooling tubes and filtered before entering the hydraulic reservoir.

SOLENOID CONTROL VALVE

A. CONTROL VALVE

B. SOLENOID

The solenoid control valve directs oil flow from the hydraulic pump. When the mower ON/OFF switch is in the "ON" position, the solenoid is energized and the spool within the valve is positioned to direct oil to the cuttershaft motor.

When the mower ON/OFF switch is in the "OFF" position, oil pressure within the valve pushes the spool back which allows the oil to circulate through the cutter unit before returning to the reservoir. When the flow of oil to the motor

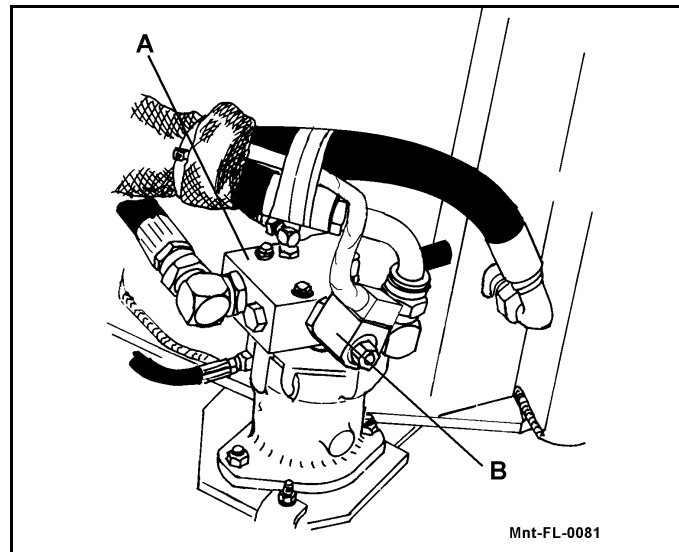

MAINTENANCE

SOLENOID CONTROL VALVE (Cont'd)

CHECKING SOLENOID VALVE

- A. With engine running, turn the mower ON/OFF switch in the "ON" position. Check voltage level at the solenoid.
- B. If it is less than 12 volts, check wiring and ground connections. Checking ground wire is as important as checking the hot wire. If voltage is sufficient, the solenoid valve is bad and will need to be replaced.

HYDRAULIC

DISASSEMBLY

1. Disconnect all hydraulic lines. Remove pump assembly from tractor.
2. Plug all ports and thoroughly clean outside of pump.
3. Clamp the end of the drive shaft in a protected jaw vise with the body of the pump up and remove the six cap screws from the back plate.
4. Use a plastic mallet and tap the back plate assembly to loosen it, then pull back plate straight up until it is free. Remove gasket.
5. Remove pump from vise and remove rotating assembly from pump housing.
6. If the pistons did not come out with the piston block, remove them, the spider, and the spider pivot.
7. The piston block assembly need not be disassembled unless the internal pins of spring is damaged.



The following procedure should be used if the spring is to be removed from the piston block assembly. The spring is highly compressed and the snap ring should not be removed without first compressing the spring.

The following parts will be needed to disassemble the piston block:

- 2 ea. 3/8 I.D. x 1-1/8 O.D. flat washer
- 1 ea. 3/8 x 3-1/4 N.C. capscrew
- 1 ea. 3/8 N.C. nut

Place one of the flat washers over the 3/8 x 3-1/4 cap screw and place this through the center of the piston block. Place the other washer over the cap screw and let it rest on the three pins. Screw the nut on and compress the spring inside the piston block. Use a pair of snap ring pliers and remove the internal snap ring. Remove the bolt and the two washers. Remove the washers, spring, three pins, and the internal pin keeper.

8. Remove snap ring from housing. Press shaft from housing and remove shaft seal and washer.
9. Remove the two snap rings, thrust bearing, and two thrust washers from the drive shaft.
10. To remove the cam plate from housing, remove the four screws from sides of the housing. Remove trunnion cover, seal cover, and o-ring cover. Remove o-ring, seal, two washers, inner race, and needle bearings. The cam plate can now be moved over to one side and removed. The cam plate pivot bearing are a loose slip fit into the housing. Do not be concerned if they are not tight.

MAINTENANCE

INSPECTION

1. Inspect flat surface of the backplate. The finish on the piston block side should be smooth and free of grooves. **DO NOT LAP BACKPLATE WEAR SURFACE.** The backplate should be replaced if it shows any of the wear characteristics outlined above. Inspect the needle bearing in the backplate. If the needles are free of excessive play and remain in the bearing cage, there is no need to replace the bearing.
2. Inspect the piston block. The wear surface that contacts the backplate should be smooth and free of grooves. **DO NOT LAP PISTON BLOCK.**
3. The pistons should move freely in the piston block bores. If they are sticky in the bore, examine the bore for scoring or contamination.
4. Examine the O.D. of the pistons for finish condition. They should not show wear or deep scratches. The shoes should be a snug fit on the ball end of the pistons. The flat surfaces of the shoes should be flat and smooth. **DO NOT LAP THE PISTON SHOES.**
5. Examine the spider. It should be flat, no cracks and no signs of wear in the pivot area.
6. Examine the pivot. It should be smooth and show no signs of wear.
7. The cam plate should be inspected for the condition of the finish of the polished shoe surface. It should show no signs of scoring. Inspect the camplate pivot bearings. If the needles are free of excessive play and remain in the bearing cage, there is no need to replace the bearing.
8. Inspect the drive shaft for fretting in the bearing and spline areas.
9. Inspect the thrust bearing and thrust washers for wear.
10. Inspect the needle bearing in the housing. If the needles are free of excessive play and remain in the bearing cage, there is no need to replace the bearing.

REASSEMBLY

1. Clean all parts in a suitable solvent. Lubricate all critical moving parts before reassembly. If necessary, install new needle bearing in housing with numbered end of bearing outward.
2. Insert cam plate into housing. Insert needle bearings and inner race. The chamfered I.D. of the race should be inward. Install washers, o-ring seal, o-ring cove, trunnion cover, seal cover, and retain with four screws and tighten to 36-48 in. lbs.
3. Install snap ring on shaft. Install thrust washer, thrust bearing, and second thrust washer. Secure with second snap ring.
4. Install shaft in housing and install washer and shaft seal and retain with snap ring.
5. Compress pin keeper and install in the spline of the piston block. Install the three pins with head end to the inside of the block, and install in the special grooves of the piston block spline.
6. Install washer, spring, and second washer in the piston block. Use the two 3/8 I.D. washers and the 3/8 x 3-1/4 cap screw to compress the spring and retain with snap ring. Remove the 3/8 x 3-1/4 cap screw and the two washers.
7. Install the pivot, spider, and the piston assemblies in the piston block. Install this assembly in the housing assembly. The piston shoes must be in contact with the cam plate. Be sure all the parts are in their proper position.
8. Clamp this assembly in a protected jaw vise with the open end of the housing up.
9. Install new gasket.
10. Install relief valves and springs into backplate.
11. Install backplate assembly. Install sixcap screws and torque to 27-31 ft. lbs.

MAINTENANCE



MAINTENANCE

HYDRAULIC MOTOR

DISASSEMBLY

1. Clean outside of unit thoroughly. Refer to Hydraulic Motor illustration in the Parts Listing section.
2. Clamp shaft in a protected jaw vise with backplate end up.
3. Remove six bolts from backplate.
4. Use a plastic mallet and tap the backplate to loosen it.
5. Remove o-ring from backplate.
6. Remove the complete piston block assembly from the housing assembly.
7. Remove piston assemblies, spider, and pivot from piston block assembly.
8. The piston block assembly need not be disassembled unless the pins or spring is damaged.



The following procedure should be used if the spring is to be removed from the piston block. The spring is highly compressed and the snap ring should not be removed without compressing the spring.

The following parts will be needed to disassemble the piston block:

- 2 ea. 3/8 I.D. x 1-1/8 O.D. flat washer
- 1 ea. 3/8 I.D. x 3-1/4 N.C. capscrew
- 1 ea. 3/8 N.C. nut

Place one of the flat washers over the 3/8 x 3-1/4 bolt and place this through the center of the piston block. Place the other washer over the bolt and let it rest on the three pins. Screw nut on and compress the spring inside the piston block. Use a pair of snap ring pliers and remove the internal snap ring. Remove the bolt and two washers. Remove the two washers, spring, three pins, and pin keeper.

9. Remove thrust race from housing.
10. Remove snap ring from housing.
11. Remove shaft seal from housing.
12. Remove washer from housing.
13. Remove drive shaft from housing.
14. Remove the two snap rings, thrust washers, and thrust bearing, from drive shaft.

MAINTENANCE

INSPECTION

1. Wash all parts thoroughly in a suitable solvent.
2. Examine needle bearings in housing and backplate.
3. Inspect thrust washers and thrust bearing. All surfaces should be free of any signs of wear or fretting.
4. Inspect spider and pivot; conical surfaces should be free of wear and score marks.
5. Inspect the pistons: the O.D. surface should be smooth and free of scoring. The shoes should be snug fit to the piston. The face of the shoes should be flat and free of scoring and flaking. **DO NOT LAP PISTON SHOES.**
6. Inspect the piston block; the bores should be free of scoring. The surface that contacts the backplate should be smooth and free of grooves or metal build-up. Do not lap piston block.
7. Inspect the thrust race; the surface should show no signs of scoring or grooves.
8. Inspect the flat surface on the backplate; it should be free of excessive scoring or metal build-up. **DO NOT LAP BACKPLATE.**
9. Inspect the drive shaft for fretting in the bearing areas. Check spline area for twisted or broken teeth. If keyed shaft, check for cracked or chipped keyway.

REASSEMBLY

1. Use filtered system oil to lubricate all critical moving parts before assembly.
2. Install one snap ring in rear groove of drive shaft. Install one thrust washer, thrust bearing, and second thrust washer on drive shaft. Install second snap ring in front groove on drive shaft.
3. Replace needle bearing in housing if necessary. Install shaft in housing assembly and install washer. Oil O.D. of new shaft seal and press into position. Retain with snap ring.
4. Compress pin keeper and install in the spline area of the piston block.
5. Install the three pins in the special grooves of the spline and with head end of pin toward inside of bock.
6. Install one washer, spring, and second washer. Use the two 3/8 I.D. washers and the 3/8 x 3-1/4 capscwew to compress the spring and retain with snap ring. Remove the 3/8 x 3-1/4 capscwew and two washers.
7. Install the pivot, spider, and the piston assemblies in the piston block assembly.
8. Lubricate thrust race and install in housing assembly.
9. Install piston block assembly in housing assembly. The piston shoes must contact the thrust race. Be sure all parts are in their proper position.
10. Install new needle bearing in backplate if necessary.
11. Install new o-ring on backplate.
12. Install backplate on housing.
13. Install six capscrews and torque 15-18 ft. lbs.
14. On through shaft type assembly, install shaft seal and snap ring in backplate. Install key in drive shaft.

MAINTENANCE

LIFT CYLINDERS

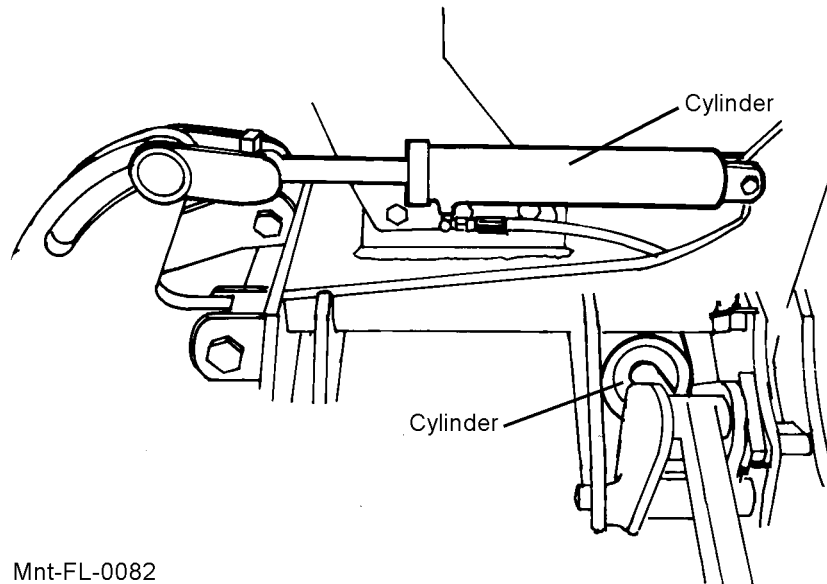

Mnt-FL-0082

DISASSEMBLY OF LIFT CYLINDER

For part numbers and illustration, refer to the Parts Listing section.

1. Disconnect hoses at cylinder. Cap all hoses to prevent fluid contamination. Remove cylinder from unit.
2. Remove reducer bushing and snap ring which retains the rod guide. Remove rod guide, rod, and piston. Remove guide and piston from rod.
3. Replace all "O" rings, back-up washers, and rod wiper. Inspect rod, guide, piston, and body for damage.
4. Clean inside of cylinder with mineral spirits. DO NOT wipe dry; air dry instead. Lint, dirt, and grit can cause immediate or premature failure.
5. Lubricate all parts with clean hydraulic oil and reassemble.
6. Reinstall cylinder with stop located on the upper side, to prevent bending the rod.

MAINTENANCE

EXTERNAL COIL SLIP CLUTCH DISK REPLACEMENT

TO DISASSEMBLE EXTERNAL COIL SPRING CLUTCH

(Refer to **Mnt-FL-0083**)

Before beginning disassembly, remove or fold shields out of the way and clean off dirt and trash from the area.

1. Remove two Attaching Bolts (6). Remove Clutch Assembly from shaft of Gearbox. Leave Driveline or Driveline Half attached to Clutch.
2. Loosen six Adjusting Bolts (1). **LOOSEN EACH BOLT A FEW TURNS AT A TIME - NOT ALL AT ONCE.** Continue in rotation until Nuts are loose. Remove these Bolts. Flange Yoke (9) will slide off. On Clutches that have Dust Shields (11), Shields will slide off with Flange Yoke.

NOTE: Some types do not have Dust Shields.

3. On the opposite side, Outer Flange (2) will slide off which will allow Clutch Plate (3) to slide over notches on outside diameter of Clutch Body (5).
4. Remove Plate with six bolt holes (7).

NOTE: Bolts (1) go through these holes.

5. Remove the four Friction Disks (4) and discard. **DO NO RE-USE.**

TO CLEAN AND INSPECT

1. Inspect all components for rust, wear, or damage. Check Spacer (8) for scoring or excessive wear. Clean Clutch Plates and Drive Plates with a wire brush as required to remove any rust.

TO REASSEMBLE

(Refer to **Mnt-FL-0083**)

1. After all parts have been inspected, cleaned or replaced as necessary, replace components in reverse order from disassembly **USING THE NEW, IMPROVED DISKS.** Do not tighten the six Adjusting Nuts and Bolts (1) until assembly is complete.

TO ADJUST

(Refer to **Mnt-FL-0083**)

1. To adjust Slip Clutch, tighten Bolts until the Nut makes contact with Compression Spring.
2. After all six Bolts have been assembled so that Nuts contact Springs, mark the position of the top flat on each Nut. Tighten Nuts 1-3/8 turns as follows:

Do NOT tighten one bolt completely. Tightening as shown in rotation will put equal pressure all the way around on Friction Disks and Drive Plates.

- a. Tighten the Nuts (Item 1) one-half turn in rotation.
- b. Tighten one-half turn again until the marks on the Nuts are on top as in the beginning.
- c. Then, carefully tighten 3/8 of a turn. As a double check, the Springs should now be COMPRESSED

TO 1-11/32" (1.34") TO 1-5/16" (1.31") long.

3. Re-assemble Clutch to Gearbox. Tighten Bolts securely.
4. If Clutch slips too easily, **STOP PTO AT ONCE.** Tighten each Adjusting Nut **NO MORE THAN ¼ TURN AT A TIME.** NEVER TIGHTEN SPRINGS SHORTER THAN 1-9/32" (1.28") LONG EVEN AFTER DISK WEAR.

NOTE: EXCESSIVE SLIPPING WILL BURN UP DISKS AND SLIP CLUTCH TO THE POINT WHERE THE CLUTCH IS NOT REPAIRABLE. HOWEVER, EXCESSIVE TIGHTENING WILL PREVENT THE SLIP CLUTCH FROM SLIPPING AND CAN LEAD TO FAILURES OF DRIVETRAIN COMPONENTS WITH RESULTING DOWNTIME.

MAINTENANCE

MAINTENANCE

TO REPLACE SHIELDS

1. Make certain that all Driveline Canopy Shields are in good repair and rotate smoothly on the Drivelines. Replace Bearings and/or Integral Shields if necessary.
2. Re-install Gearbox Canopy Shields with the same hardware and tighten securely.

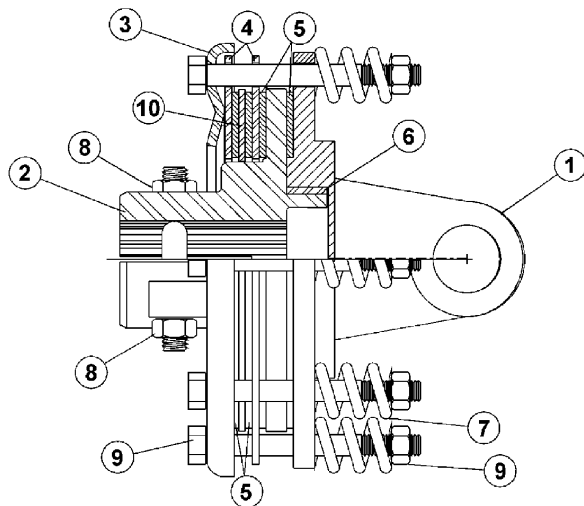

SPRING CLUTCH

Mnt-FL-0083

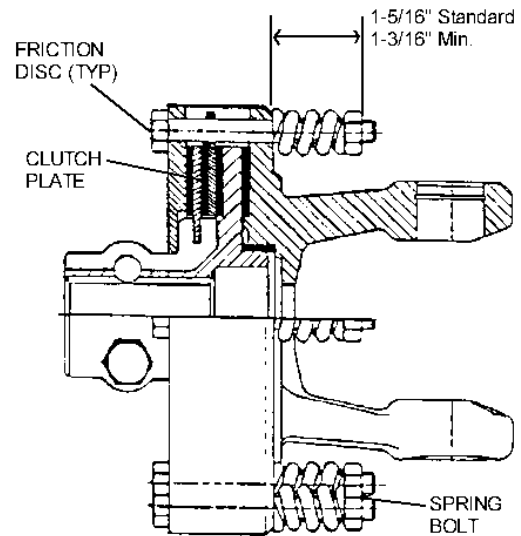

SLIP CLUTCH ADJUSTMENT

Mnt-FL-0084

ITEM	PART NO.	QTY	DESCRIPTION
1	00754302	1	Flange Yoke
2	00755599	1	Clutch Support
3	00766810	1	Pressure Plate
4	00754314	2	Plate with Holes
5	00754202	4	Lining Ring
6	00754301	1	Bushing
7	00754303	8	Spring
8	00755600	2	Nut & Bolt
9	00754199	8	Nut & Bolt
10	00754201	1	Intermediate Plate

SLIP CLUTCH PRECAUTIONS

If MOWER is to sit outside FOR 30 DAYS or more and be exposed to rain or humid air, the CLUTCHES should be removed and STORED IN A DRY AREA.

However, if CLUTCHES are left outside for 30 days or more, make certain that you follow BREAK-A-WAY INSTRUCTIONS shown below.

It is very important to check for and FREE-UP EVERY FROZEN CLUTCH to prevent drivetrain's overloading and possible failure of drivetrain or tractor components.

MAINTENANCE

TO TEST FOR FROZEN CLUTCHES

1. Mark across Clutch Disks and Plates plainly with soft chalk so that you can tell if Clutch slips (would misalign the marks).
2. With mower lifted off the ground, PTO engaged, and tractor engine at half throttle, let the tractor clutch out rapidly to see if all Slip Clutches will slip.
3. If all Clutches slip and provide protection for the drivetrain, you are ready to mow if you have performed all normal maintenance.

MACHINE IS STORED OUTSIDE FOR 30 DAYS OR MORE

1. Before mowing, back off all Adjusting Nuts (1) until Nuts just touch Springs (10). Then, tighten Nuts one full turn uniformly (**Mnt-FL-0083**).
2. Mark Plates and Disks as in A.1. above. With PTO engaged and tractor running at **HALF THROTTLE**, let Clutch out rapidly to “pop” Slip Clutches loose. If all Slip Clutches slip as is necessary, adjust as is shown at “D” on other side, and you are ready to mow if you have completed all normal maintenance.

When adding hydraulic oil, use only new oil from a sealed barrel. Used oil or oil from an open barrel may contain high levels of contamination. Transfer the new oil into the hydraulic tank by using a hydraulic filter pump unit equipped with a properly operating 10 micron filter. This will insure that the oil being added is clean. Do not just pour the oil directly into the hydraulic tank since most oils (even from a sealed barrel) have contaminants that should be removed, before operating the hydraulic system.

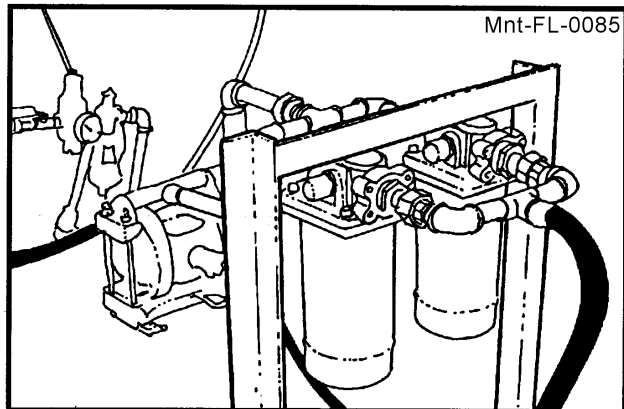
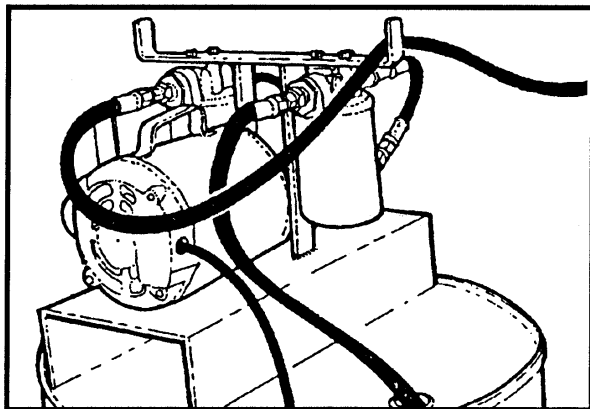

ATTENTION!

Buy clean Universal Tractor Hydraulic Oil and keep it clean. Always clean off filler area and add new oil through a filter.

MAINTENANCE

VERSA PRO TANK FILLING INSTRUCTIONS

USE Universal Tractor Hydraulic oil only.

A VERSA PRO will require approximately 26 gallons of oil to fill the hydraulic tank, hoses, and cooling tubes in the mower deck. The Hydraulic tank only holds 15 gallons of oil and you can not add enough oil to the tank the first time to completely fill the system. Therefore, the following filling instructions must be carefully followed to prevent pump cavitation and instant pump failure.

1. After the VERSA PRO mower is completely assembled to the tractor and with the wings on the ground, fill the mower hydraulic tank above the oil level sight gauge approximately 1" below the top of the tank. Use Universal Tractor Hydraulic Oil only.
2. Start the tractor and engage PTO for 30 to 45 seconds and then turn it off.
3. Check the oil level in the sight gauge. If no oil is seen, add oil to bring the level up to the sight gauge.

NOTE: Do not fill the tank with oil above the level of the sight gauge after the first filling. Over-filling the tank with oil after the initial filling may result in oil being discharged through the air filter on top of the hydraulic tank.

4. Start the tractor and engage PTO for 2 minutes and then turn it off.
 5. Again check the oil level in the sight gauge. If the oil level is in the sight gauge, the unit is ready to run no oil is seen, add oil to bring the level up to the sight gauge.
 6. Repeat steps 4 and 5 as required until the oil level stabilizes at the level of the sight gauge.
- Use Hydraulic Oil Chevron 1000 THF or an equivalent.

Note: Your ambient temperature and operating conditions may require a different viscosity oil. Please consult the oil manufacturer for proper specifications.

Cylinder Rod Maintenance

It is important to visually inspect the hydraulic cylinder rods daily before use. It is highly recommended that while the machine is stored or getting very little use that a protectant is applied to the hydraulic cylinder rods to prevent degradation. If the machine receives more frequent use, be sure to fully cycle each cylinder function so that the cylinder rod is coated by the systems hydraulic fluid. Depending on your operating environment it may be necessary, under normal operating conditions, to apply a protective lubricant to the cylinder rods for protection against rust and pitting. Hydraulic fluid may provide a suitable amount of protection, but remember any protectant can attract dust and debris so attention must be given to the cylinder rods daily. Also remember that any other protectant must be compatible with hydraulic fluid. Alamo Industrial is not responsible for rust or pitting of the cylinder rod due to weather exposure or impacts from normal operation or mounting. If hydraulic cylinders and or the cylinder rods are damaged as a result of the rods rusting or pitting, the hydraulic cylinders and rods will not be covered under warranty by Alamo Industrial.

MAINTENANCE

STORAGE

Your mower represents an investment from which you should get the greatest possible benefit. Therefore, when the season is over, the mower should be thoroughly checked and prepared for storage so that a minimum amount of work will be required to put it back into operation for the next season. The following are suggested storage procedures:

1. Thoroughly clean the mower.
2. Lubricate the cutter as covered in Maintenance Section.
3. Tighten all bolts and pins to the recommended torque.
4. Check the mower for worn or damaged parts. Make replacements immediately.
5. Store the mower in a clean, dry place with the mower head resting on blocks.
6. Use spray touch-up enamel where necessary to prevent rust and maintain the appearance of the mower.



PROPER TORQUE FOR FASTENERS

The chart lists the correct tightening torque for fasteners. When bolts are to be tightened or replaced, refer to this chart to determine the grade of bolts and the proper torque except when specific torque values are assigned in manual text.





RECOMMENDED TORQUE IN FOOT POUNDS UNLESS OTHERWISE STATED IN THE MANUAL*

NOTE: These values apply to fasteners as received from supplier, dry or when lubricated with normal engine oil. They do not apply if special graphited or molydisulphide grease or other extreme pressure lubricants are used. This applies to both UNF fine and UNC coarse threads.

Proper Torque values for bolts that are measured in Inches

Bolt Diameter			
	Head Marking No Marks Grade Two Pound - Foot Value Dry	Head Marking Three Lines Grade Five Pound - Foot Value Dry	Head Marking Six Lines Grade Eight Pound - Foot Value Dry
1/4"	5.5	9	12.5
5/16"	11	18	26
3/8"	20	33	46
7/16"	32	52	75
1/2"	50	80	115
9/16"	70	115	160
5/8"	100	160	225
3/4"	175	280	400
7/8"	175	450	650
1"	270	675	975
1-1/8"	375	850	1350
1-1/4"	530	1200	1950
1-3/8"	700	1550	2550
1-1/2"	930	2100	3350

Proper Torque values for Metric bolts

Bolt Diameter				
	Head Marking 4.8 Pound - Foot Value Dry	Head Marking 8.8 or 9.8 Pound - Foot Value Dry	Head Marking 10.9 Pound - Foot Value Dry	Head Marking 12.9 Pound - Foot Value Dry
6mm	4.5	8.6	12	14.5
8mm	11	20	30	35
10mm	21	40	60	70
12mm	37	70	105	120
14mm	60	110	165	190
16mm	92	175	255	300
18mm	125	250	350	410
20mm	180	350	500	580
22mm	250	475	675	800
24mm	310	600	850	1000
27mm	450	875	1250	1500
30mm	625	1200	1700	2000

*To get Newton-Meters multiply pound-foot of torque by 1.356

ALAMO-INDUSTRIAL LIMITED WARRANTY

1. LIMITED WARRANTIES

- 1.01. Alamo Industrial warrants for one year from the purchase date to the original non-commercial, governmental, or municipal purchaser ("Purchaser") and warrants for six months to the original commercial or industrial purchaser
- 1.02. Manufacturer will replace for the Purchaser any part or parts found, upon examination at one of its factories, to be defective under normal use and service due to defects in material or workmanship.
- 1.03. This limited warranty does not apply to any part of the goods which has been subjected to improper or abnormal use, negligence, alteration, modification, or accident, damaged due to lack of maintenance or use of wrong fuel, oil, or lubricants, or which has served its normal life. This limited warranty does not apply to any part of any internal combustion engine, or expendable items such as blades, shields, guards, or pneumatic tires except as specifically found
- 1.04. Except as provided herein, no employee, agent, Dealer, or other person is authorized to give any warranties of any nature on behalf of Manufacturer.

2. REMEDIES AND PROCEDURES.

- 2.01. This limited warranty is not effective unless the Purchaser returns the Registration and Warranty Form to Manufacturer within 30 days of purchase.
- 2.02. Purchaser claims must be made in writing to the Authorized Dealer ("Dealer") from whom Purchaser purchased the goods or an approved Authorized Dealer ("Dealer") within 30 days after Purchaser learns of the facts on which the claim is based.
- 2.03. Purchaser is responsible for returning the goods in question to the Dealer.
- 2.04. If after examining the goods and/or parts in question, Manufacturer finds them to be defective under normal use and service due to defects in material or workmanship, Manufacturer will:
 - (a) Repair or replace the defective goods or part(s) or
 - (b) Reimburse Purchaser for the cost of the part(s) and reasonable labor charges (as determined by Manufacturer) if Purchaser paid for the repair and/or replacement prior to the final determination of applicability of the warranty by Manufacturer.

The choice of remedy shall belong to Manufacturer.

- 2.05. Purchaser is responsible for any labor charges exceeding a reasonable amount as determined by Manufacturer and for returning the goods to the Dealer, whether or not the claim is approved. Purchaser is responsible for the transportation cost for the goods or part(s) from the Dealer to the designated factory.

3. LIMITATION OF LIABILITY.

- 3.01. MANUFACTURER DISCLAIMS ANY EXPRESS (EXCEPT AS SET FORTH HEREIN) AND IMPLIED WARRANTIES WITH RESPECT TO THE GOODS INCLUDING, BUT NOT LIMITED TO, MERCHANTABILITY AND FITNESS FOR A PARTICULAR PURPOSE.
- 3.02. MANUFACTURER MAKES NO WARRANTY AS TO THE DESIGN, CAPABILITY, CAPACITY, OR SUITABILITY FOR USE OF THE GOODS.
- 3.03. EXCEPT AS PROVIDED HEREIN, MANUFACTURER SHALL HAVE NO LIABILITY OR RESPONSIBILITY TO PURCHASER OR ANY OTHER PERSON OR ENTITY WITH RESPECT TO ANY LIABILITY, LOSS, OR DAMAGE CAUSED OR ALLEGED TO BE CAUSED DIRECTLY OR INDIRECTLY BY THE GOODS INCLUDING, BUT NOT LIMITED TO, ANY INDIRECT, SPECIAL, CONSEQUENTIAL, OR INCIDENTAL DAMAGES RESULTING FROM THE USE OR OPERATION OF THE GOODS OR ANY BREACH OF THIS WARRANTY. NOT WITHSTANDING THE ABOVE LIMITATIONS AND WARRANTIES, MANUFACTURER'S LIABILITY HEREUNDER FOR DAMAGES INCURRED BY PURCHASER OR OTHERS SHALL NOT EXCEED THE PRICE OF THE GOODS.
- 3.04. NO ACTION ARISING OUT OF ANY CLAIMED BREACH OF THIS WARRANTY OR TRANSACTIONS UNDER THIS WARRANTY MAY BE BROUGHT MORE THAN TWO (2) YEARS AFTER THE CAUSE OF ACTION HAS OCCURRED.

4. MISCELLANEOUS.

- 4.01. Proper Venue for any lawsuits arising from or related to this limited warranty shall be only in Guadalupe County, Texas.
- 4.02. Manufacturer may waive compliance with any of the terms of this limited warranty, but no waiver of any terms shall be deemed to be a waiver of any other term.
- 4.03. If any provision of this limited warranty shall violate any applicable law and is held to be unenforceable, then the invalidity of such provision shall not invalidate any other provisions herein.
- 4.04. Applicable law may provide rights and benefits to purchaser in addition to those provided herein.

KEEP FOR YOUR RECORDS

ATTENTION: Purchaser should fill in the blanks below for his reference when buying repair parts and/or for proper machine identification when applying for warranty.

Alamo Industrial Implement Model _____ Serial Number _____

Date Purchased _____ Dealer _____

ATTENTION:

READ YOUR OPERATOR'S MANUAL

ALAMO INDUSTRIAL
An Alamo Group Company
Post Office Drawer 549
Seguin, Texas 78156
830-379-1480





TO THE OWNER/OPERATOR/DEALER

To keep your implement running efficiently and safely, read your manual thoroughly and follow these directions and the Safety Messages in this Manual. The Table of Contents clearly identifies each section where you can easily find the information you need.

The OCCUPATIONAL SAFETY AND HEALTH ACT (1928.51 Subpart C) makes these minimum safety requirements of tractor operators:

REQUIRED OF THE OWNER:

1. Provide a Roll-Over-Protective Structure that meets the requirements of this Standard; and
2. Provide Seatbelts that meet the requirements of this paragraph of this Standard and SAE J4C; and
3. Ensure that each employee uses such Seatbelt while the tractor is moving; and
4. Ensure that each employee tightens the Seatbelt sufficiently to confine the employee to the protected area provided by the ROPS.

REQUIRED OF THE OPERATOR

1. Securely fasten seatbelt if the tractor has a ROPS.
2. Where possible, avoid operating the tractor near ditches, embankments, and holes.
3. Reduce speed when turning, crossing slopes, and on rough, slick, or muddy surfaces.
4. Stay off slopes too steep for safe operation.
5. Watch where you are going - especially at row ends, on roads, and around trees.
6. Do not permit others to ride.
7. Operate the tractor smoothly - no jerky turns, starts, or stops.
8. Hitch only to the drawbar and hitch points recommended by the tractor manufacturer.
9. When the tractor is stopped, set brakes securely and use park lock, if available.

- Keep children away from danger all day, every day...
- Equip tractors with rollover protection (ROPS) and keep all machinery guards in place...
- Please work, drive, play and live each day with care and concern for your safety and that of your family and fellow citizens.



BC-0001