

Troubleshooting Guide

Problem	Reason	Solution
Unit does not turn on.	1. Power Cord	1. Check to make sure power cord is plugged in or properly connected to HVAC unit.
	2. AHPCO™ Cell	2. Check to make sure UV lamp within AHPCO™ Cell in plugged in completely.
	3. Indicator Light Not Working	3. Make sure exposed end of black fiber optic cord is exposed to the UV light.

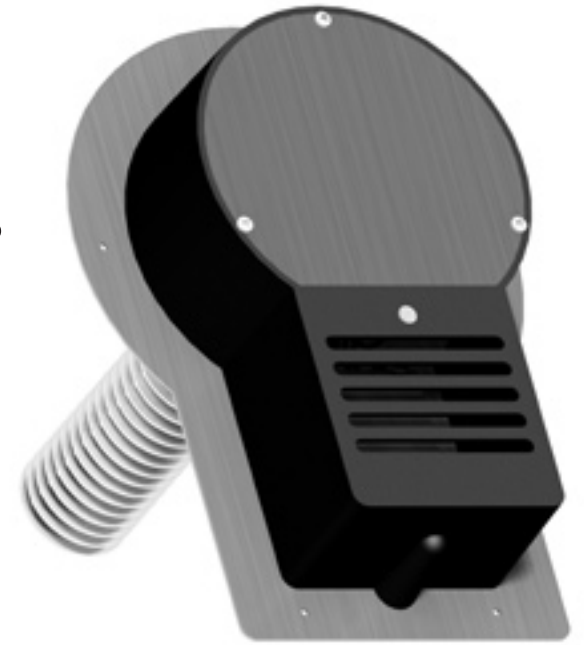

Induct 9 Owner's Manual



This Manual Includes:

- Warranty
- Safety Warnings
- Installation Instructions
- Operating Instructions
- Replacement Directions
- Troubleshooting Tips



3401 Airway Blvd
Amarillo, TX 79118

Toll-Free: 1-800-936-1764 Fax: 1-806-373-7799
www.AirOasis.com

Copyright© 2006 Air Oasis All Rights Reserved



Before operating this unit or replacing the AHPCO™ Cell carefully read the contents of this manual.

Introduction

The air you breathe is filled with thousands of particles of air pollution. Some of the pollutants like dust and lint are large enough to be visible to the naked eye, but pollutants such as pollen, smoke, germs, bacteria, etc., are microscopic in size. Your Air Oasis™ Induct ACT™ air purifier has been designed to destroy these invisible pollutants and provide your home or place of work with the luxury of clean air.

The AHPCO™ Cell is designed to help eliminate sick building syndrome risks by reducing airborne microbes, contaminants, VOCs and odors, with our advanced AHPCO process. The AHPCO Cell is contained within the Induct ACT™ unit. When the Earth Care system is in operation the AHPCO Cell uses an Advanced Hydrated Photocatalytic Oxidation process to reduce airborne contaminants.

Why use Hydrated Photocatalytic Oxidation?

Germicidal UV light rays have been used for decades by the medical industry as a method for destroying micro-organisms (germs, viruses, bacteria). Germicidal UV light is effective in reducing airborne micro-organisms that pass through the light rays. However, germicidal UV light has little to no effect on gases, vapors or odors.

Ozone, on the other hand, is very effective on gases, vapors, VOCs and odors. However, too much ozone can be a health hazard, and traditional methods of producing ozone (i.e. corona discharge) have maintenance problems and create nitric acid and nitric oxides which can cause damage to the respiratory system. The combination of ozone (O₃) and UV light, in the presence of our patent-pending quad-nano Xtreme™ catalyst, creates the Advanced Oxidation reaction. This advanced reaction chamber creates ozone gas and destroys it within the same chamber by converting it to friendly oxidizers. This oxidation further attacks the micro-organisms as well as significantly reducing odors and VOCs. By engineering the proper light wavelengths in the dual function AHPCO Cell, we have effectively designed a system that will not exceed the recommended Federal Safety Limits for ozone (.04 ppm) in an occupied room, while still providing reductions in odors and microbials.

With the **Earth Care AHPCO Cell**, many gases and odors are abated, micro-organism reductions can be as much as 99%, and the room will have safe, low ozone levels no greater than forest air, (.01 - .02 ppm) or air after a thunderstorm, which gives the room fresh, clean odor-free air.

Step 3

Remove three (3) wing-nuts securing the AHPCO Cell in place. Then slide the AHPCO Cell up and out of the unit.



UV lamp may be hot and could cause serious burns if not handled properly. Please wait until AHPCO Cell has cooled to room temperature to remove from unit.

AHPCO™ Cell contains Hg (Mercury) and should be disposed of according to disposal laws. Find disposal centers at www.earth911.org.



Step 4

Reverse steps 1-3 to set new AHPCO Cell in place. Be sure to place the exposed tip of the fiber optic cord between the first rings of the new AHPCO Cell and in close proximity to the UV lamp. This will ensure the indicator light functions properly.

Replacement Date Reminder

The AHPCO™ Cell should be replaced every three years.

3 Years Date: _____

6 Years Date: _____

9 Years Date: _____

Hg lamp contains mercury. Manage in accord with disposal laws. Find disposal centers at www.earth911.org.

Induct 9 Installation Instructions

Step 1

Tear out the cutout template and trace the rectangle onto the ductwork.

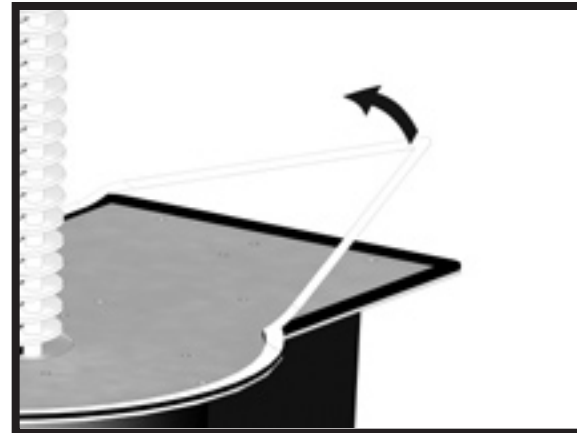
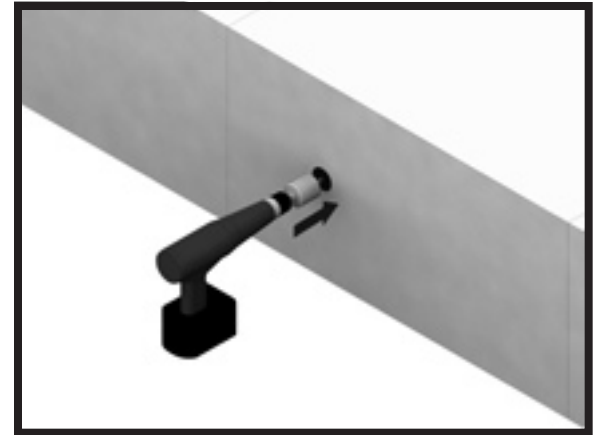

Step 2

Drill holes at each corner of the rectangle. trace the rectangle onto the ductwork.

Step 3
Insert unit into
pre-cut hole.

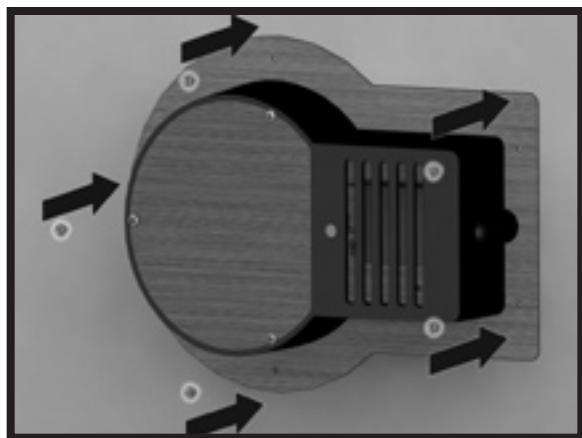
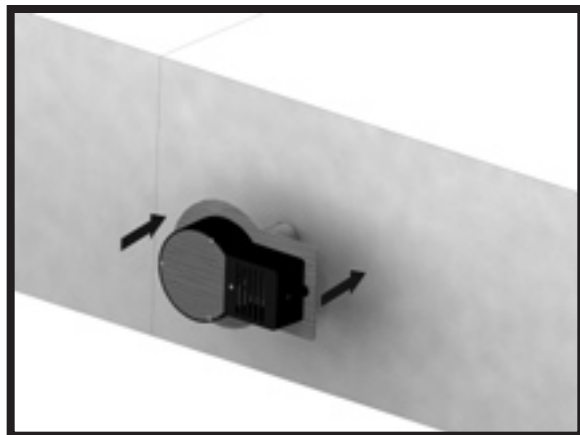

Step 4
Drill the metal
tapping screws in to
hold unit in place.

If you do not have a hole saw tear this page off and cut the circle out. Then place on the ductwork in desired position and trace the rectangle. Drill holes as indicated and then use a jig saw or metal cutting snips to cut out the circle.

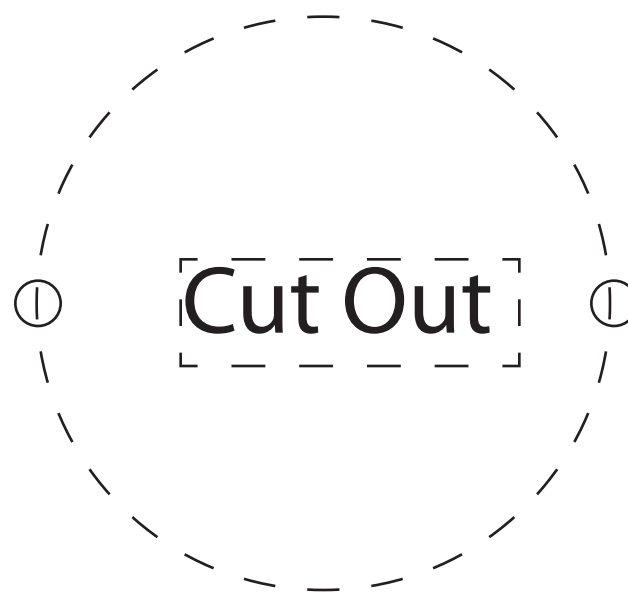

Step 4

Plug the power cord into an electrical outlet. You may optionally have an electrician wire the air purifier to your HVAC unit so that the air purifier only operates when your HVAC fan is running. Once the unit is plugged in the indicator light should glow to indicate the AHPCO Cell is working properly.

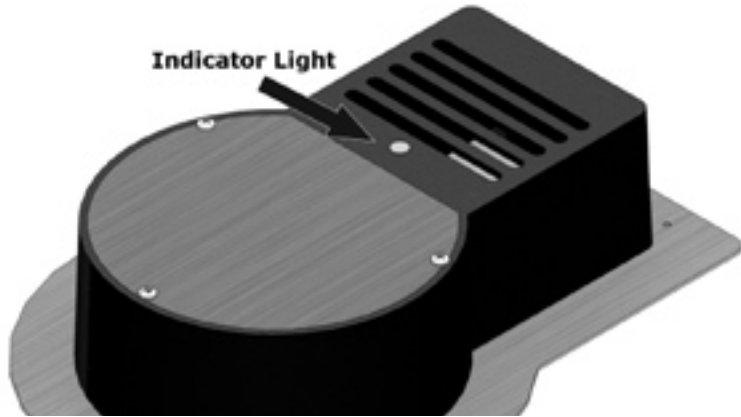

AHPCO™ Cell Replacement

Step 1



CAUTION: Before attempting to service the Air Oasis unit, be sure the power is off and unplugged.

Remove three (3) screws at the top of the aluminum face plate. Then slide the face plate up and off.

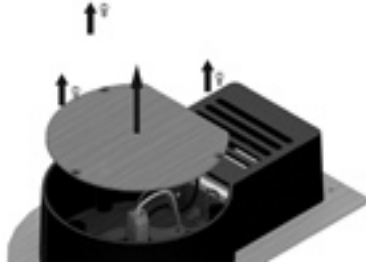

Step 2

Unplug the four pin lamp connectors and fiber optic cords from the AHPCO Cell.

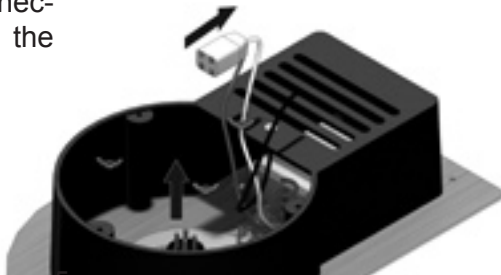

Read all instructions carefully before operating your air purifier.

Table of Contents

Introduction	1
Safety Instructions and Cautions	2
Warranty	3
Maintenance and Customer Service	4
Installation and Operation	4-5
Replacement Parts	5-6
Troubleshooting Guide	7

Important Safety Instructions

When operating electrical appliances, basic precautions should always be followed.

WARNING To reduce the risk of fire, electric shock or injury:

- Do not use outdoors or on wet surfaces.
- Use only as described in this manual.
- Do not use with damaged cord or plug. If appliance is not working as it should, has been dropped, damaged, left outdoors, or dropped into water, call customer service at 1-800-936-1764.
- Do not unplug by pulling on cord. To unplug, grasp the plug, not the cord.
- Do not handle plug or appliance with wet hands.
- Do not put any object into openings.
- Unplug from power source before performing any maintenance or removing front cover.
- It's strongly recommended that only a licensed electrician or HVAC installer properly install this unit.



CAUTION



AHPCO™ Cell contains Hg (Mercury) and should be disposed of according to disposal laws. Find disposal centers at www.earth911.org.

If the UV lamp is broken do not touch the cell or glass with your hands.

UV lamp may be hot and could cause serious burns if not handled properly. Please wait until the AHPCO Cell has cooled to room temperature to remove from unit.

Warranty

Air Oasis gives you the following limited warranty for this product only if it was originally purchased for residential or commercial use but, not resale from Air Oasis or an Air Oasis Authorized Retail Dealer.

Air Oasis will repair or replace, free of charge, to the original purchaser, any part that is found to be defective in material or workmanship within three (3) years of the date of purchase.

This limited warranty covers the replacement of a defective AHPCO Cell for a period of three years.

This limited warranty does not apply to any part subjected to accident, abuse, certain commercial uses, alteration, misuse, damage caused by act of God, the use of voltages other than indicated on the label displayed on this product or service of this product by anyone other than Air Oasis.

Air Oasis does not authorize any person or representative to assume or grant any other warranty obligation with the sale of this product.

Air Oasis' limited warranty is valid only if you retain proof of purchase from Air Oasis or an Air Oasis Authorized Retail Dealer for this product. If you purchase this product from any other source, your purchase is "AS IS", which means Air Oasis grants you no warranty, and that you, not Air Oasis, assume the entire risk of the quality and performance of this product, including the entire cost of any necessary servicing or repairs of any defects.

Air Oasis' liability for damages to you for any costs whatsoever arising out of this statement of limited warranty shall be limited to the amount paid for this product at the time of original purchase, and Air Oasis shall not be liable for any direct, indirect, consequential or incidental damages arising out of the use or inability to use this product.

ALL EXPRESS AND IMPLIED WARRANTIES FOR THIS PRODUCT, INCLUDING IMPLIED WARRANTIES OF MERCHANTABILITY AND FITNESS FOR A PARTICULAR PURPOSE, ARE LIMITED IN DURATION TO THE WARRANTY PERIOD, AND NO WARRANTIES, WHETHER EXPRESS OR IMPLIED, WILL APPLY AFTER THIS PERIOD.

Some states do not allow limitations on the duration of implied warranties, so the above limitation may not apply to you. This warranty gives you specific legal rights, and you may also have other rights which vary from state to state.

To obtain warranty service and return authorization number, contact us at:
PH: (800) 936-1764, FAX: (806) 373-7799 or E-mail to feedback@airoasis.com
NOTE: All returned packages that do not have an RMA# will be refused.

Maintenance and Customer Service

If you require any additional information or have problems with your Air Oasis appliance, you may call Air Oasis customer service at:

1-800-936-1764

Please have your serial and model numbers, found on bottom of the unit, handy when calling.

Save your sales receipt to show if your Air Oasis appliance should ever need any warranty service.

Installation and Operation



It's strongly recommended that only a licensed electrician or HVAC installer properly install this unit.

The purifiers can be installed on either the return or supply side of the plenum.

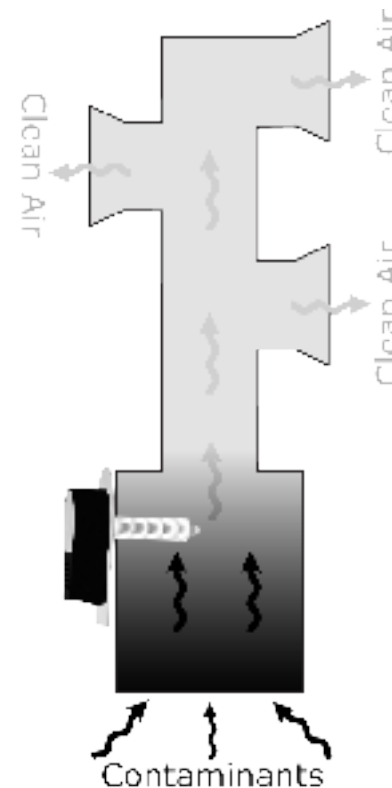

Step 1

Cut a 2" hole in the plenum using a hole saw. Make sure the hole is centered so that no part of the mounting plate is hanging off the edges of the plenum when the probe is inserted.

Step 2

Insert the probe into the 2" hole until the back mounting plate is flush against the plenum surface. We recommend mounting the unit with the rectangular side facing either left or right, but not down or up.

Step 3

Attach the mounting plate to the plenum surface using sheet metal screws. There are predrilled holes on the mounting plate that can be used as a guide. It's recommended to seal the edges of the mounting plate using aluminum insulation tape.