

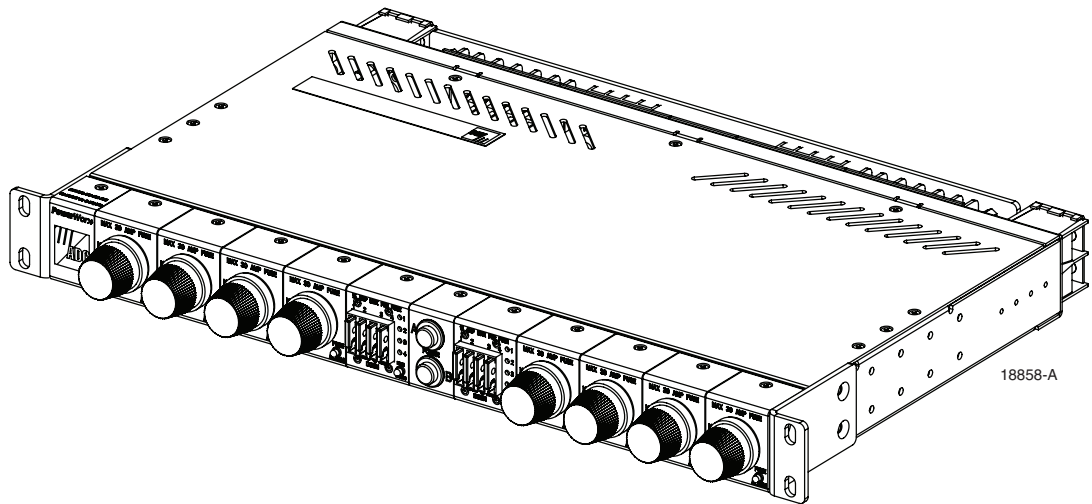

PowerWorx[®] Power Distribution Products Select Series[™] Fuse Platform (With Enhanced KLM Fuses) User Manual



18858-A

COPYRIGHT

© 2006, ADC Telecommunications, Inc.
All Rights Reserved
Printed in the U.S.A.

REVISION HISTORY

ISSUE	DATE	REASON FOR CHANGE
1	11/2006	Original.
2	12/2006	Figure 3 block diagram changed to show dual bus; minor changes in section 1.8 and table 1.

TRADEMARK INFORMATION

PowerWorx is a registered trademark of ADC Telecommunications, Inc.
ADC is a trademark of ADC Telecommunications, Inc.

DISCLAIMER OF LIABILITY

Contents herein are current as of the date of publication. ADC reserves the right to change the contents without prior notice. **In no event shall ADC be liable for any damages resulting from loss of data, loss of use, or loss of profits and ADC further disclaims any and all liability for indirect, incidental, special, consequential or other similar damages. This disclaimer of liability applies to all products, publications and services during and after the warranty period.**

This publication may be verified at any time by contacting ADC's Technical Assistance Center at 1-800-366-3891, extension 73475 (in U.S.A. or Canada) or 952-917-3475 (outside U.S.A. and Canada), or by e-mail to connectivity_tac@adc.com.



ADC Telecommunications, Inc.
P.O. Box 1101, Minneapolis, Minnesota 55440-1101
In U.S.A. and Canada: 1-800-366-3891
Outside U.S.A. and Canada: (952) 938-8080
Fax: (952) 917-1717

TABLE OF CONTENTS

Content	Page
About This Manual	v
Standards Certification	v
Admonishments	v
General Safety Precautions	v
1 PRODUCT DESCRIPTION	1
1.1 Product Functions and Features	1
1.2 Fuse Platform Components	1
1.3 Product Options	3
1.4 Packaged Hardware	4
1.5 Accessories	6
1.6 Mounting	6
1.7 Power Buses	6
1.8 Bus Capacity	8
1.9 Input Voltage	8
1.10 Input Power Connectors	8
1.11 Output Power Connectors	9
1.12 Ground Connectors	10
1.13 Alarm Contact Operation	10
1.14 Alarm Contact Connectors	10
1.15 Fuse Alarm Indicators	10
1.16 Power-On Indicator	11
1.17 Fused Equipment Designation Card and Holder	11
1.18 Voltage Designation Label	12
1.19 Environmental Characteristics	12
1.20 Material and Finish	12
1.21 Cooling	12
1.22 Protective Cover	13
1.23 Weight	13
1.24 Dimensions	13
2 UNPACKING AND INSPECTION	14
3 PRE-INSTALLATION	14
3.1 General Installation Recommendations	14
3.2 Installation Tools Required	14
3.3 Materials Required	15
3.4 Continuity Tests	15
4 INSTALLATION	17
4.1 Installing Cable Management Bar (Optional Item)	18
4.2 Mounting Fuse Platform on Rack	19
4.3 Grounding Chassis	20
4.4 Connecting Alarms	21
4.5 Connecting Output Power	22

TABLE OF CONTENTS

Content	Page
4.6 Connecting Input Power	23
4.7 Installing Protective Covers	25
4.8 Installing GMT Fuse Designation Pins	26
4.9 Installing Fuse Designation Card Holder and Card	26
4.10 Installing Voltage Designation Label	26
5 SYSTEM CHECK	26
5.1 Wiring Connections Torque Measurements	26
5.2 Power On and Connection Polarity Test	26
5.3 GMT Fuse Alarm Test and Installation	27
5.4 TPA Fuse Alarm Test and Installation	27
5.5 KLM Fuse Alarm Test and Installation	27
6 OPERATION	28
6.1 Clearing a KLM Fuse Alarm	28
7 MAINTENANCE	29
7.1 Inspection	29
7.2 Cleaning	29
7.3 Fuse Removal	29
8 CUSTOMER INFORMATION AND ASSISTANCE	30
A APPENDIX A: ALLOWABLE AMPACITIES OF INSULATED CONDUCTORS	31

ABOUT THIS MANUAL

This manual describes the PowerWorx® Select Series™ Fuse Platform and provides installation, operation, maintenance, and testing procedures. The Select Series™ Fuse Platform is available with various types of fuses including TPA, KLM, and GMT fuses. Two types of fuses can be combined within the same platform, if required. Within this manual, the Select Series™ Fuse Platform is referred to as the “Select Series™ fuse platform” or the “fuse platform”.

STANDARDS CERTIFICATION

The fuse platform complies with the applicable sections of the following standards: UL, Telcordia, NEC 1999, CE, IEC, CSA, and NEBS Level 3.

ADMONISHMENTS

Important safety admonishments are used throughout this manual to warn of possible hazards to persons or equipment. An admonishment identifies a possible hazard and then explains what may happen if the hazard is not avoided. The admonishments — in the form of Dangers, Warnings, and Cautions — must be followed at all times. These warnings are flagged by use of the triangular alert icon (seen below), and are listed in descending order of severity of injury or damage and likelihood of occurrence.



Danger: *Danger is used to indicate the presence of a hazard that **will** cause severe personal injury, death, or substantial property damage if the hazard is not avoided.*



Warning: *Warning is used to indicate the presence of a hazard that **can** cause severe personal injury, death, or substantial property damage if the hazard is not avoided.*



Caution: *Caution is used to indicate the presence of a hazard that **will** or **can** cause minor personal injury or property damage if the hazard is not avoided.*

GENERAL SAFETY PRECAUTIONS



Warning: *The fuse platform uses electrical voltage and current levels that may be considered an electrical hazard. Care should be exercised to assure that only qualified personnel are allowed to install, operate, maintain, or otherwise come into contact with this equipment when the fuse platform is energized. Only insulated tools should be used on energized elements of the fuse platform.*



Caution: *All fuse platform wiring and cabling should be connected with the system office battery input off or disconnected at the office distribution panel.*



Caution: *A replacement fuse must be of the same type and current rating as the fuse being replaced.*



Warning: *Wet conditions increase the potential for receiving an electrical shock when installing or using electrically-powered equipment. To prevent electrical shock, never install or use electrical equipment in a wet location or during a lightning storm.*

1 PRODUCT DESCRIPTION

This section describes the PowerWorx Select Series Fuse Platform.

1.1 Product Functions and Features

The Select Series Fuse Platform, shown on the front cover of this manual, supplies protected dc power to the –24 Vdc or –48 Vdc equipment typically installed in a central office, multimedia headend, remote site, Controlled Environmental Vault (CEV), or other restricted locations. The fuse platform is available in a single or dual bus configuration and in several configurations of fuse types. The fuse platform provides the following important features:

- 19-inch or 23-inch EIA or WECO rack mounting.
- Self-configuring input voltage capability to –24 Vdc or –48 Vdc.
- GMT, KLM, or TPA fuse types alone (with corresponding fuse holder modules), or GMT in combination with either of the other two types.

▶ **Note:** KTK fuses will also fit in the KLM fuse holder, but are not currently rated for dc voltages by Underwriters Laboratories (UL).

- “Upside down” GMT fuse holders making blown fuses easier to see.
- Optimally-positioned, high-brilliance fuse alarm (red LED) indicators, providing quick identification of blown fuses.

▶ **Note:** For KLM fuses, there is a two-color (green/red) LED for each fuse position. A green LED indicates a good fuse. A red LED indicates a failed fuse or a removed fuse. A method is available to disable the LED (no green or red light) when a fuse holder is left empty on purpose (see [Section 6.1 on Page 28](#)).

- Field-replaceable high-brilliance power-on (green LED) indicators (one per bus).
- Easy-to-remove plastic protective covers for input and output terminals.
- Two-hole compression-lug terminals for input power connections.
- Two grounding studs for robust and reliable ground connectivity.
- Screw-down barrier terminal strips for power output connections.
- Relay contacts for alarms (corresponding to red LEDs above). The alarm contacts may be used to open or close a loop connected from an external alarm system.

1.2 Fuse Platform Components

The Select Series Fuse Platform, shown in [Figure 1](#), is a customer-configurable product containing either one or two power buses. Each power bus is connected to multiple fuse holder modules. In a dual bus platform, the two buses are mirror images of one another, having the same types of fuses and the same size fuse holder modules.

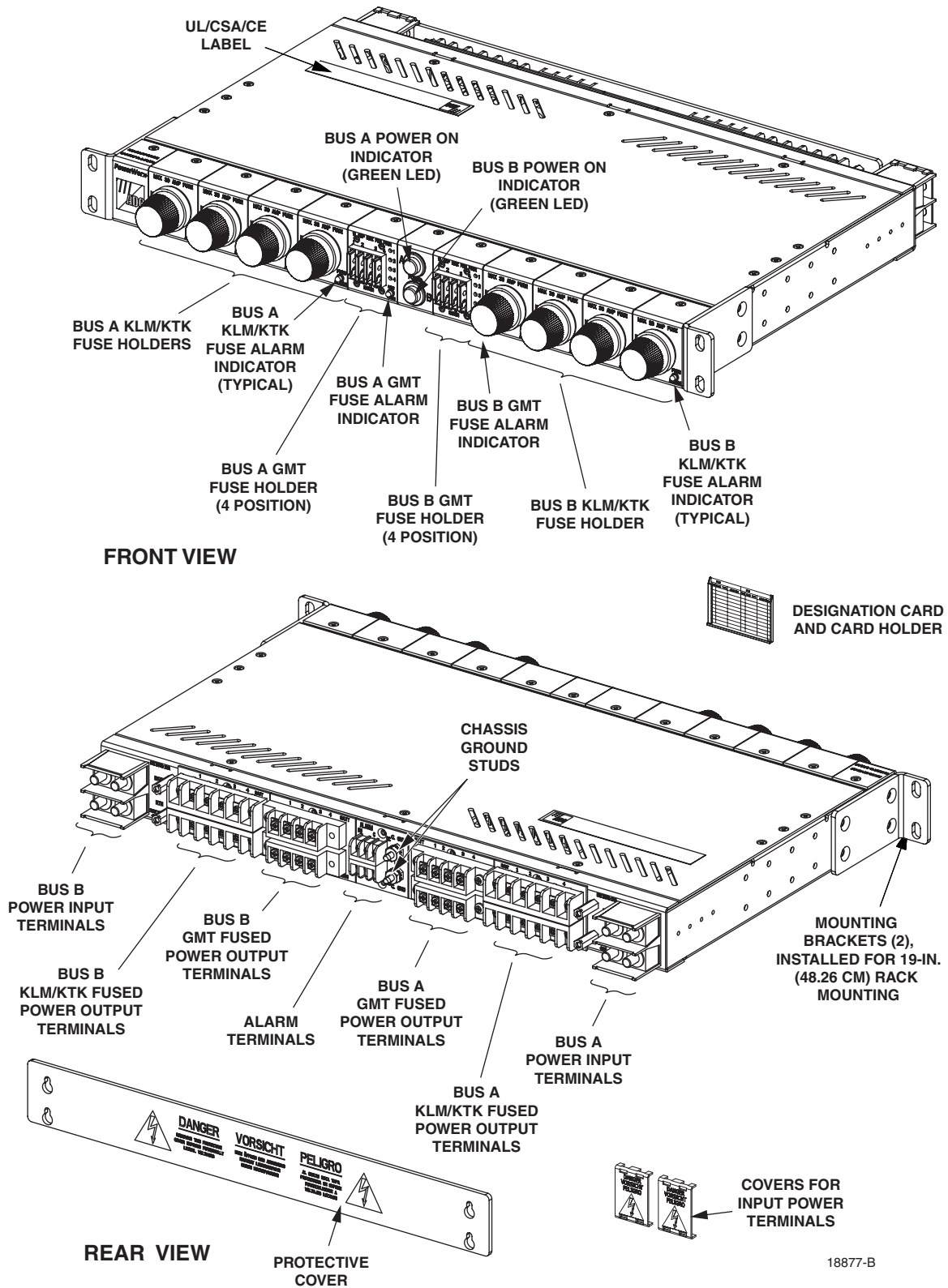

Figure 1. Dual Bus KLM-GMT Fuse Platform



Warning: *Use of one bus only on a dual bus panel will result in false alarms for the unused bus. Power is required on both buses on a dual bus panel for normal operation.*

Depending on customer order, the fuse platform may have one fuse type alone, or GMT fuses in combination with one other fuse type (KLM or TPA). The number of fuse positions on each bus is dependent on the maximum current limit, as well as on the current value of the fuses and the width of the fuse holders. The maximum current input per bus is 100 Amps.

- ▶ **Note:** The continuous output load of the equipment during normal operation should not exceed 80% of the rated value of the fuse. This allows some room for manufacturing tolerances and voltage fluctuations in the plant power mains.

Figure 1 shows the external features of a typical fuse platform (in this case, a dual bus fuse platform with four KLM and four GMT fuses per bus).

1.3 Product Options

The following configurations of fuses are available:

- Four TPA fuses with four or ten GMT fuses
- Two or four KLM or KTK fuses with four or ten GMT fuses
- Any of the above fuse types alone including:
 - Four TPA fuses per bus
 - Two or four KLM or KTK fuses per bus
 - Ten GMT fuses per bus

Fuse capacity varies per fuse type (see [Section 1.8, Bus Capacity on page 8](#)). The total fuse output cannot exceed 100 Amps per bus (200 Amps per dual bus platform).

- ▶ **Note:** The continuous output load of the equipment during normal operation should not exceed 80% of the rated value of the fuse. This allows some room for manufacturing tolerances and voltage fluctuations in the plant power mains.

All fuse platforms have power-on LEDs that light in green indicating the presence of power and fuse alarm LEDs that light in red indicating a blown fuse. In addition, the fuse alarm LEDs on the enhanced KLM fuse platform have a green state indicating that a fuse is installed and receiving power.

Two types of alarm contacts are available: wire wrap or screw-down barrier terminal strip.

Two fuse platform mounting options are available: EIA/WECO or ETSI. (All fuse platforms can be installed in either a 19-inch or 23-inch rack. The fuse platform comes with mounting brackets for both rack widths.)

1.4 Packaged Hardware

The fuse platform is shipped with hardware components (shown in [Figure 2](#)) that are packaged separately and enclosed in the same carton. The packaged hardware components include the following items:

- Two sets of mounting brackets (for 19-inch or 23-inch rack mounting)—Used to mount the panel on the equipment rack.
- 5/16-inch long, Phillips drive, 8-32 flat-head thread-forming screws (8)—Used to secure the mounting brackets to the panel.
- 3/8-inch long, combination drive, 12-24 pan-head screws (4) and #12 flat washers (4)—Used to secure the mounting brackets to the equipment rack.
- #10 ring terminals (2) for 12–10 AWG wire—Used to connect the grounding cables to the grounding studs.
- Rear protective input terminal covers and output terminal covers—Used to prevent accidental contact with the power input and output terminals. The number of covers provided depends on the fuse configuration.
- Designation card and card holder—Used to record information about the protected equipment. The card holder has a pressure-sensitive adhesive backing to permit attachment to the panel, the rack, or a location close to the panel. The designation card inserts into the card holder. It is also available as an accessory item.

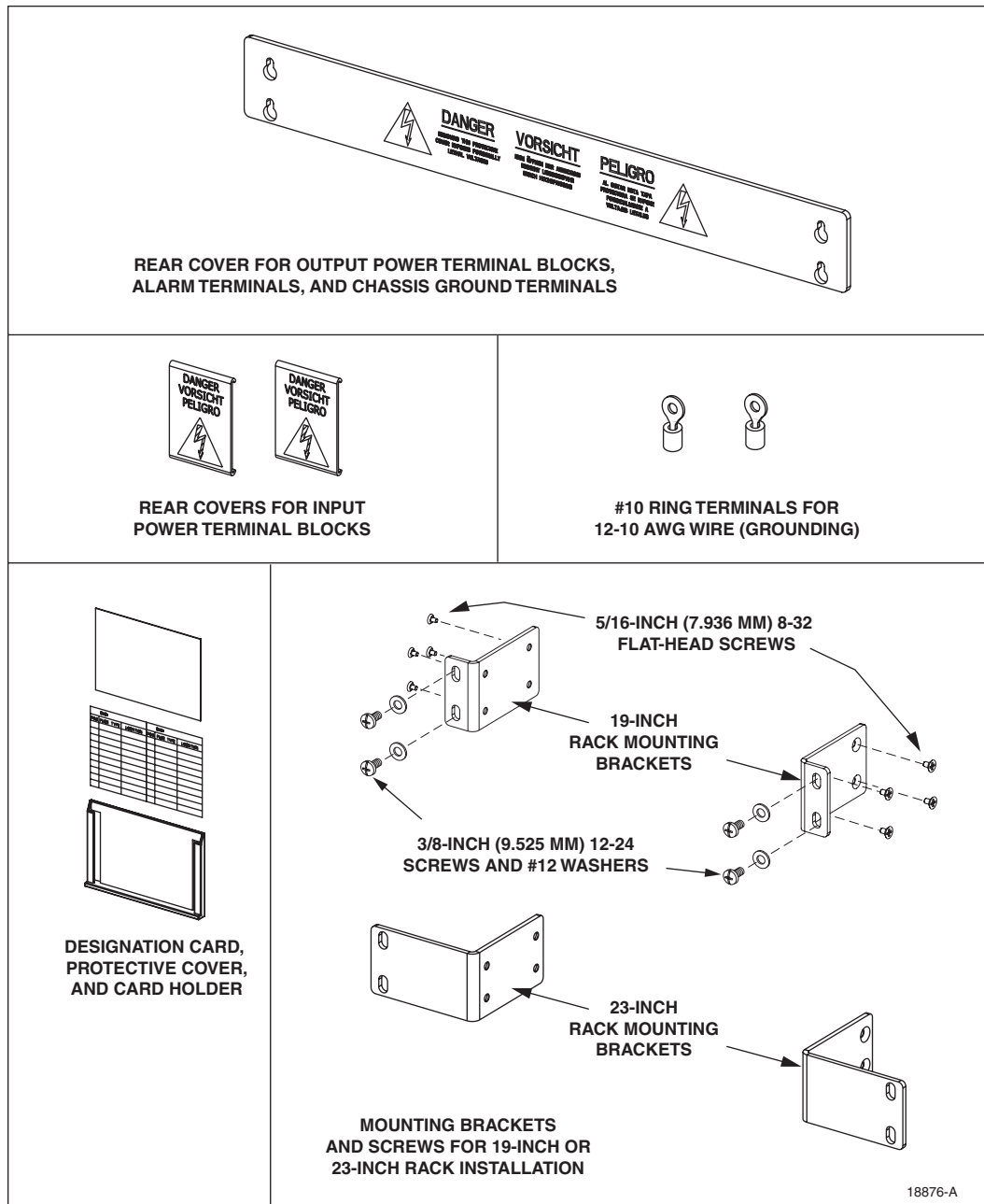

Figure 2. Packaged Hardware Components

1.5 Accessories

The following accessories are available for the fuse platform:

- Standard size GMT, KLM, and TPA type fuses
- GMT colored fuse-value designation pins (rivets)
- Cable management bar kits
- GMT fuse pullers
- Two-hole compression connector lugs for input power connections
- Lug terminals to connect #10 AWG wire to earth ground
- GMT fuse value designation pin holders
- Fuse value designation card holder kits

1.6 Mounting

The fuse platform can be mounted in a 19-inch (48.26 cm) or a 23-inch (58.42 cm) equipment rack. Two pairs of mounting brackets, one pair for 19-inch racks and one pair for 23-inch racks, are provided with the fuse platform. The fuse platform can be flush mounted or recessed 1, 2, 3, or 4 inches (2.54, 5.08, 7.62 or 10.16 cm) from the front of the rack. The mounting brackets allow mounting in racks with WECO 1.00-inch (2.54 cm) hole spacing or EIA 1.25-inch (3.18 cm) hole spacing. The slotted hole pattern in the mounting brackets compensates for vertical rack differences and allows the fuse platform to be mounted in either 1.75- or 2-inch (4.45 or 5.08 cm) rack spaces.

1.7 Power Buses

The fuse platform is available with one or two separate power buses. Each bus distributes the input power to multiple fused output circuits. In each bus circuit, current flows from the input connector to the fuse bus. When a fuse is installed in a fuse holder, the circuit is completed to the corresponding output connector. [Figure 3](#) provides a block diagram of the power buses in a typical fuse platform (dual bus model shown).

Fuse failure is sensed by a sensor which causes the alarm monitor to light a red LED indicator on the front of the fuse holder. The function of the fuse failure indicator differs depending on fuse type as follows:

- For GMT fuses, there is a red LED indicator for each set of fuses (depending on product configuration, each fuse holder holds four or ten fuses). Fuse failure also opens and closes a set of alarm contacts (form C dry contacts) connected to the alarm output terminals. There is one such set of alarm contacts for each bus, with failure of any fuse on the bus causing an alarm condition.
- For TPA fuses, there is an individual red LED indicator for each individual fuse because each fuse holder holds a single fuse.
- For KLM fuses, there is an individual two-color indicator (green/red LED) for each fuse. The indicator functions as follows:

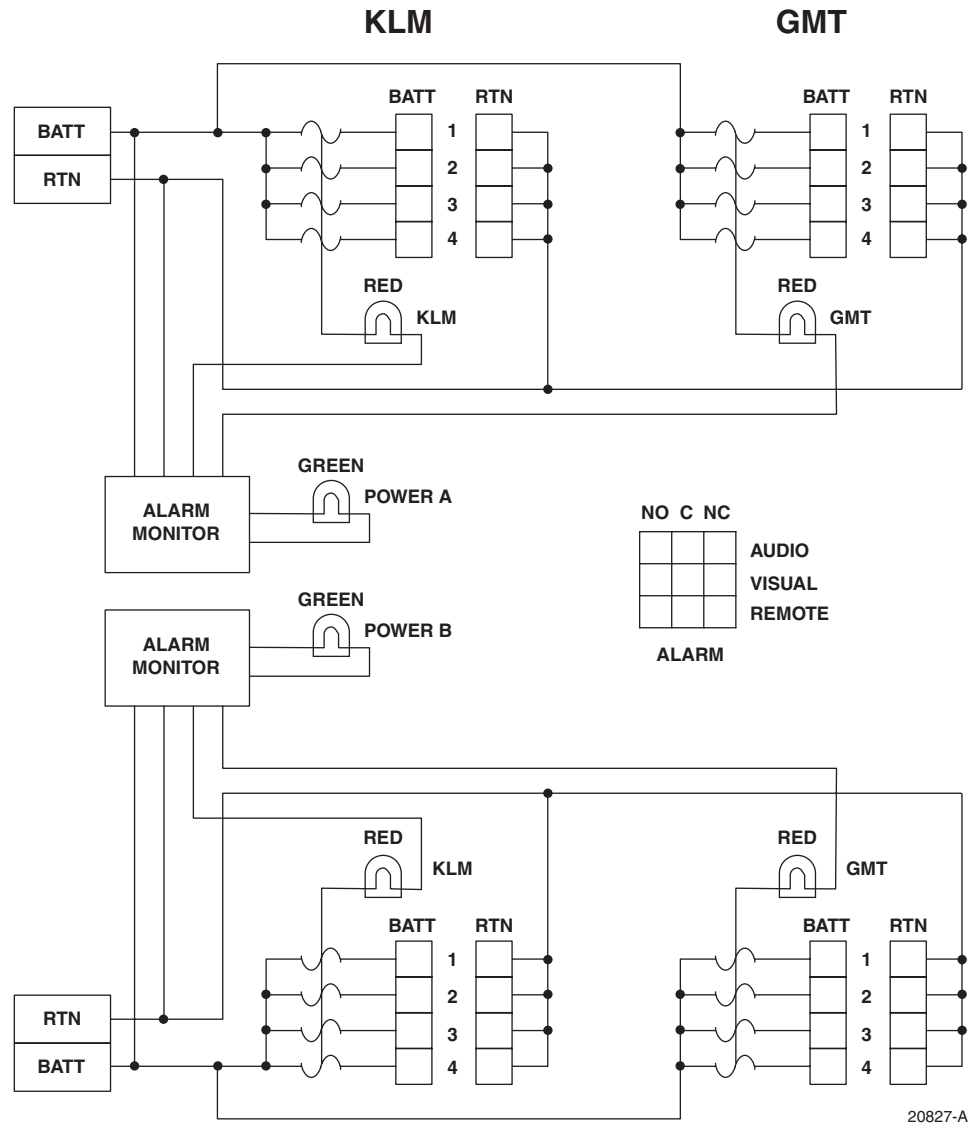

Figure 3. Block Diagram of GMT-KLM Bus

- Initially, if there is no input power to the A or B bus, or if there is no fuse placed in the KLM fuse holder, the LED will be unlit (no green or red light).
- The first time a KLM fuse is installed in the fuse holder, the LED will turn to green to indicate that the position has power available for the output terminal for that fuse position. It will remain green until there is a fuse failure or until a fuse is removed from that fuse holder.
- At the time of a fuse failure, or if the fuse is removed, the LED will turn red and activate an alarm. When the failed fuse is replaced, the new fuse will act as described for the initial turn-up, turning green to indicate a power available condition. At the same time, the new fuse will clear the alarm.

- An alarm can be cleared in any KLM fuse position by installing a new fuse and removing it when the green LED flashes. When the alarm is cleared, the LED changes from red to unlit (no red light or green light). The LED remains unlit until a good fuse is installed, whereupon it turns green. For the alarm clearing procedure, refer to [Section 6.1 on Page 28](#).

The maximum current capacity of each power bus circuit is 100 Amps. The total output current capacity of the fuses on each bus must, therefore, not exceed 100 Amps. The maximum current rating is marked on the fuse platform rear side. The power dissipation of the panel is 80 watts maximum per fuse platform (40 watts per bus at 100 Amps).

1.8 Bus Capacity

The current capacity of each power bus is 100 Amps maximum, which is marked above the input connectors on the rear of the fuse platform. The total current of a fuse platform with two buses is 200 Amps maximum. The power dissipation of the fuse platform is 80 watts maximum per fuse platform (40 watts per bus at 100 Amps).

- ▶ **Note:** The continuous output load of the equipment during normal operation should not exceed 80% of the rated value of the fuse. This allows some room for manufacturing tolerances and voltage fluctuations in the plant power mains.

The following lists the maximum current that each type of fuse can provide:

- TPA type fuse (each fuse in four position module): 50 Amps max.
- KLM type fuse (each fuse in two, four, or five position modules): 30 Amps max.
- GMT type fuse (each fuse in four position module): 15 Amps max.
- GMT type fuse (each fuse in 10 position module): 10 Amps max.

1.9 Input Voltage

The fuse platform can accommodate –24 Vdc input power on both busses or –48 Vdc input power on both busses. The voltage is sensed by the fuse platform circuitry.

The input voltage used with the fuse platform is required to have the following voltage characteristics:

- –24 Vdc nominal, within a range of –21 Vdc to –30 Vdc
- –48 Vdc nominal, within a range of –42 Vdc to –56 Vdc

1.10 Input Power Connectors

Input power to the power bus is supplied through an input power terminal block located on the rear side of the fuse platform. Dual bus fuse platforms have a separate input terminal block for each bus. If two buses are present, the terminal blocks are designated A and B, corresponding to the two power buses.

Each input terminal block includes two pairs of 0.25-inch studs that are used for connecting the BATT (battery –) and RTN (return +) input power cables. Each pair of studs is mounted on 0.625 inch centers and accepts various size 2-hole compression lugs. The maximum lug width is 0.62 inches.

Compression lugs for various sizes AWG wire are available as accessory items. Nuts with captive washers are included to secure the compression lugs to the studs. The input terminal blocks are located on the rear side of the panel.

The minimum recommended wire size for the input power wiring is #2 AWG copper wire. In selecting wire size, follow local code referring to the ampacity guidelines provided in Appendix A of this manual.

1.11 Output Power Connectors

Depending on the fuse configuration used, the fuse platform will have at least one, and up to four, output power terminal blocks, located on the rear side of the platform. The number present will depend on the fuse type and number of fuse positions. In general, there will be one terminal block per bus for each fuse type present on that bus.

All of the output power terminal blocks are screw-down barrier terminal strips. The terminal screws are of various sizes corresponding to the current load of the fuses. Each individual output has two terminals, battery (BATT) and return (RTN).

Copper wire is used for output power wiring. Connections are typically made using spade-type or ring connectors crimped onto the output wires.

Table 1 gives terminal screw size, maximum terminal width, and accepted wire gauge. In selecting wire size, follow local code referring to the ampacity guidelines provided in Appendix A of this manual.

Table 1. Output Power Terminal Blocks

FUSE TYPE	FUSE HOLDER MODULE	TERMINAL SCREW SIZE	MAXIMUM TERMINAL WIDTH	LUG/AWG RANGE *
KLM	All sizes	8-32	0.320 inch (8.128 mm)	#10 to #22
TPA	All sizes	8-32	0.320 inch (8.128 mm)	#10 to #22
GMT	4- or 5-position	6-32	0.325 inch (8.255 mm)	#12 to #22
GMT	10-position	6-32	0.260 inch (6.604 mm)	#14 to #22
TPA/GMT	4 TPA fuses with	8-32	0.320 inch (8.128 mm)	#10 to #22
	10 GMT fuses	3-48	0.200 inch (5.080 mm)	#16 to #24

* Output terminal accepts wire sizes in the AWG range given; however, wire size should be determined based on local requirements and practice.

1.12 Ground Connectors

Two #10 studs (with nuts) are provided for grounding the fuse platform chassis. The studs are mounted on 0.625 inch (15.875 mm) centers.

Two crimp ring lug terminals for two #10 AWG wires are provided with each fuse platform. The fuse platform may be grounded using only one stud.

1.13 Alarm Contact Operation

The fuse platform contains circuitry that opens and closes a set of alarm contacts when any fuse on the bus fails or when input power to the bus is lost. These contacts may be used to open or close a loop connected to an external alarm system.

The alarm circuitry uses form C alarm relay dry contacts. During normal operation (power applied and all fuses operational), the normally open (NO) contacts remain open and the normally closed (NC) contacts remain closed. When a fuse fails on either bus or power to either is lost, the NO contacts close creating a connection from NO and common and the normally closed (NC) contacts open creating an open circuit between NC and common. The current rating for each set of alarm relay contacts (either two or three sets of contacts are provided) is 110 Vdc/125 Vac maximum voltage, 1.0 Amp maximum switching current.

1.14 Alarm Contact Connectors

The fuse platform is available with either screw-down barrier terminal strips or wire wrap pins for the alarm contact connections. The following describes both types of contact connections:



Warning: *Use of one bus only on a dual bus panel will result in false alarms for the unused bus. Power is required on both buses on a dual bus panel for normal operation.*

- Screw-down barrier terminal strip: Six terminals with 3-48 screws are mounted in a barrier type terminal block. The terminals are on 0.25 inch (6.35 mm) centers with a maximum distance between barriers (maximum connecting terminal width) of 0.20 inch (5.08 mm). The alarm terminal strip has two sets of three terminals (NO, C, and NC) for use with two alarm systems. The terminals can accept #16 to #30 AWG copper wire with insulation stripped back. In selecting wire size, follow local code referring to the ampacity guidelines provided in Appendix A of this manual.
- Wire-wrap terminal block: Nine wire-wrap pins are mounted in a terminal block for both buses. The alarm terminal block has three sets of three wire-wrap pins (NO, C, NC), for use with three alarm systems. The wire-wrap pins can accept #22 to #26 AWG copper wire with insulation stripped back. In selecting wire size, follow local code referring to the ampacity guidelines provided in Appendix A of this manual.

1.15 Fuse Alarm Indicators

A visual fuse alarm indicator (red LED) is provided on the front of each fuse holder module. The fuse alarm indicator lights when any fuse in the corresponding fuse holder fails. The fuse

1.18 Voltage Designation Label

A voltage designation label, shown in [Figure 5](#), is provided with the fuse platform. The label may be filled out with the actual voltage present on the buses and placed on the fuse platform. The voltage designation label has a pressure sensitive adhesive backing for attachment.

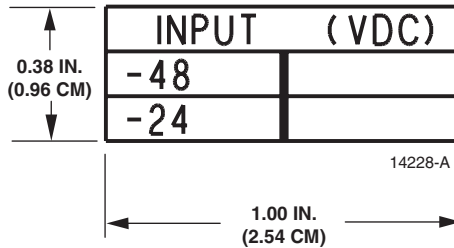

Figure 5. Voltage Designation Label

1.19 Environmental Characteristics

[Table 2](#) lists the environmental characteristics of the fuse platform.

Table 2. Fuse Platform Environmental Characteristics

PARAMETER	DESCRIPTION
Operating temperature	-5° C to +50° C
Storage temperature	-45° C to +85° C
Humidity range (operating)	0% to 95% humidity (non-condensing)
Altitude range	-197 ft. (0.06 km) to 13,000 ft. (3.96 km) above sea level
Fire rating	All components UL94-V1
Earthquake design	NEBS Level 3; Zone 4
Acoustic noise	0 dBA above ambient
Heat dissipation (fully loaded)	80 watts maximum per fuse platform @ 100 Amps (40 watts maximum per bus @ 100 Amps)
Heat dissipation (no load)	1 watt per bus

1.20 Material and Finish

The fuse platform chassis and brackets are made of 16 gauge cold rolled steel. The fuse platform and brackets are finished with powder paint that is putty white color.

1.21 Cooling

Vent openings are provided in the top and bottom of the fuse platform. The vent openings allow convection cooling of all components without the use of fans or blowers. A minimum of 1.75

inches (4.45 cm) of air space (one rack space) must be provided above and below the fuse platform to allow air to circulate freely.

1.22 Protective Cover

A smoked plastic protective cover is mounted over the input power connectors, the output power connectors, the chassis ground terminals, and the external alarm contact connections. To access the connectors and terminals, loosen (do not remove) the four screws.

1.23 Weight

The weight of the fuse platform is approximately 12.5 pounds (5.675 kilograms).

1.24 Dimensions

Figure 6 shows the dimensions of the fuse platform.

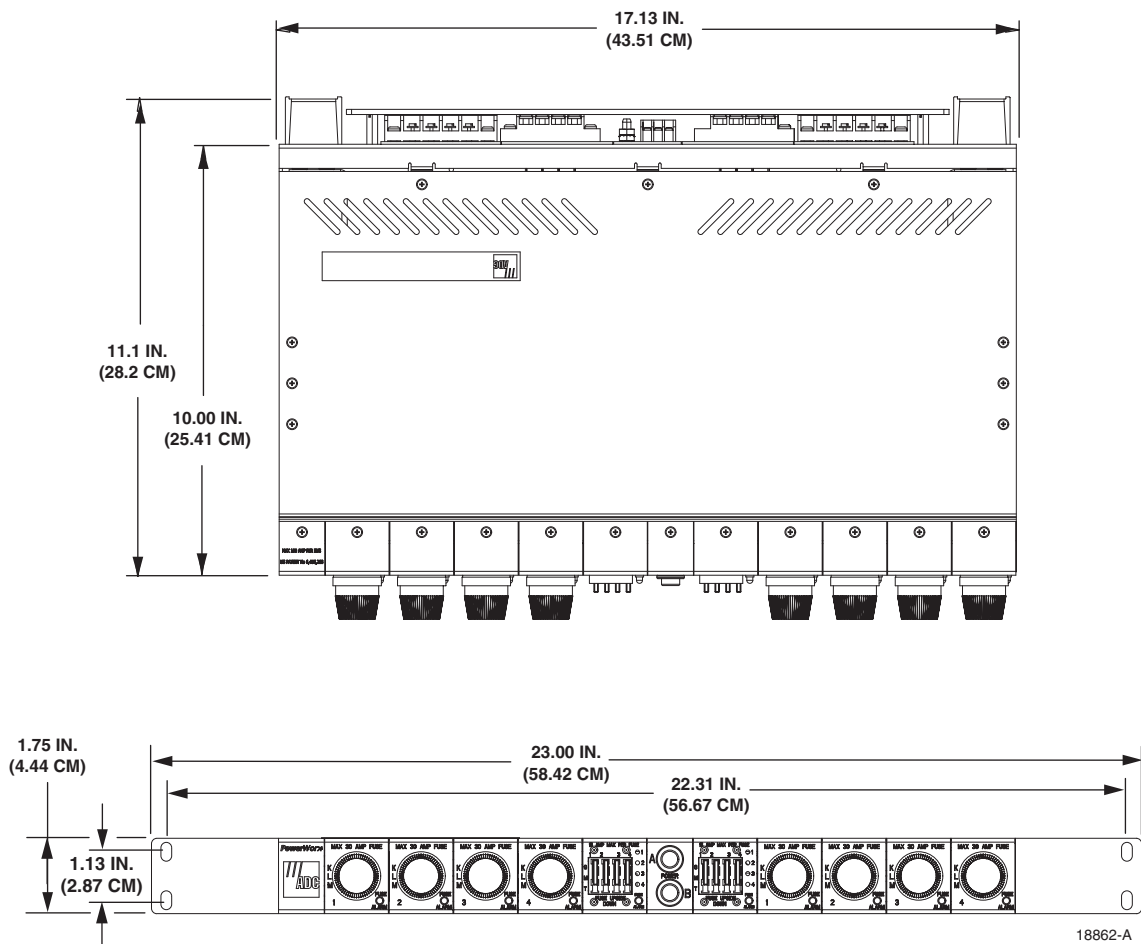

Figure 6. Dimensions of Select Series Fuse Platform

2 UNPACKING AND INSPECTION

Before starting the installation, always open the shipping boxes and verify that all parts have been received and that no shipping damage has occurred. Use the following procedure to unpack and inspect the fuse platform:

1. Open the shipping carton and carefully unpack the fuse platform from the protective packaging.
2. Check the panel for broken or missing parts. If there are any damages, contact ADC (see [Section 8, Customer Information and Assistance on page 30](#) for an RMA (Return Material Authorization) and to reorder if replacement is required.

3 PRE-INSTALLATION

This section contains general installation recommendations, unpacking and inspection procedures, a list of tools and materials required, and continuity test procedures.

3.1 General Installation Recommendations

The fuse platform should be installed in a central office, equipment room, or restricted access location. Observe the following guidelines when installing the fuse platform:

- Mount the fuse platform in the upper area of the rack or cabinet to reduce exposure of the power wiring. Provide a minimum of 1.75 inches (4.45 cm) of air space (one rack space) above and below the fuse platform to allow air to freely circulate.
- Be aware that adding a fuse platform to the rack may displace a device which may require relocation.
- Use common hand tools to install the fuse platform (see [Section 3.2](#) below). The use of a power screwdriver to install the self-tapping screws that attach the mounting brackets to the rack is also recommended.

3.2 Installation Tools Required

The following tools are required to install the fuse platform:

- Phillips screwdrivers (#1 and #2)
- Flat-blade screwdrivers (medium and large)
- Torque screwdriver calibrated in pound-force inches or Newton meters
- Torque wrench calibrated in pound-force inches or Newton meters
- 3/8-inch and 7/16-inch sockets (for torque wrench)
- Wire cutter and wire stripper
- Compression lug crimper
- Wire-wrap tool
- Multimeter
- Heat gun

3.3 Materials Required

The following materials are required to install the fuse platform:

- #2 AWG insulated copper wire for input power wires
- 2-hole compression lugs for #2 AWG wire (0.625 inches between centers)
- #10 AWG copper wire for ground connections
- Insulated copper wire for fused output power wires (refer to [Table 1 on page 9](#))
- Spade-type connectors for output power wires
- #16 to #30 AWG insulated copper wire for alarm terminal screw-down barrier terminal strip connectors (if present)
- #22 to #26 AWG insulated copper wire for alarm terminal wire-wrap pins (if present)
- Heat-shrink tubing

3.4 Continuity Tests

Each panel is thoroughly tested at the ADC factory before being shipped. However, before the panel is installed, continuity tests, as described here, should be performed to verify that no internal damage has occurred during shipping and handling.

Using a multimeter that is set to perform a continuity check, perform the following tests.

Test 1: Input Battery to Input Return—Perform this test on each input power terminal block. Connect one test probe to the input power BATT (–) terminal and the other test probe to the input power RTN (+) terminal. Verify that no continuity exists between the input power BATT and RTN terminals. [Figure 7](#) shows test points on dual bus fuse platform with A and B input power terminal blocks.

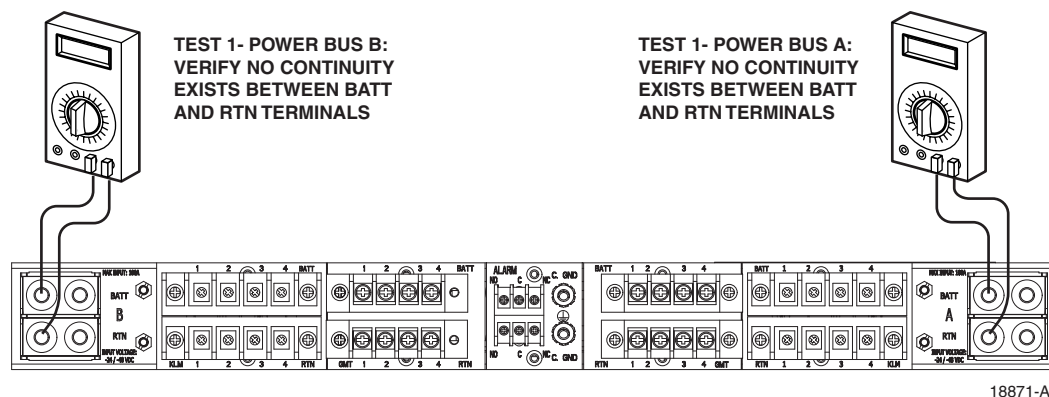

Figure 7. Test 1: Input Battery to Input Return

Test 2: Input Battery to Output Battery—Perform this test for each fuse position and fuse type (refer to [Figure 8](#) and [Figure 9](#)).

1. Remove the fuse holder from the fuse platform.
2. Insert a working fuse into the fuse holder.

3. Re-install the fuse holder (with working fuse).
 4. Connect one test probe to the BATT (–) terminal on the input power terminal block.
 5. Connect the other test probe to the BATT terminal on the output power terminal block.
 6. Verify that continuity exists between the specified terminals.
 7. Repeat the test procedure for the second fuse type, if present.
 8. Repeat the test procedure for the second power bus, if present.
- **Note:** When done, remove the working fuse from the fuse holder following completion of this test and reinstall an empty fuse holder in each fuse holder position.

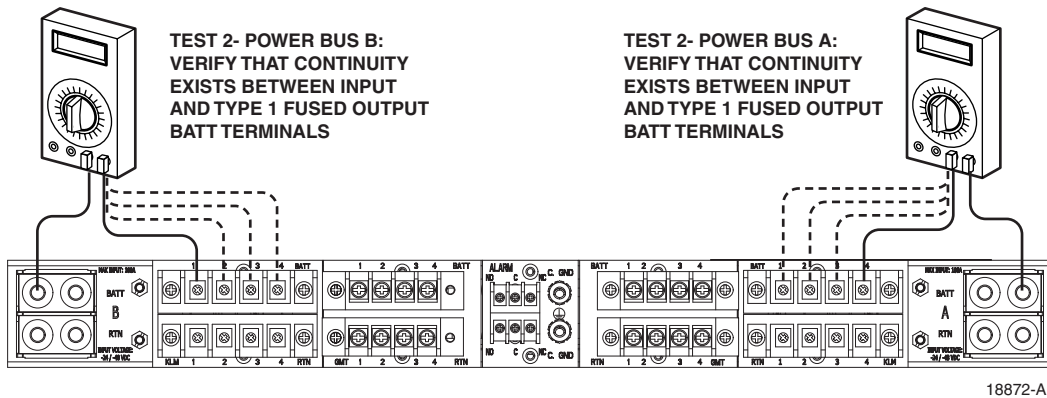

Figure 8. Test 2: Input Battery to Output Battery (Type 1 Fuse)

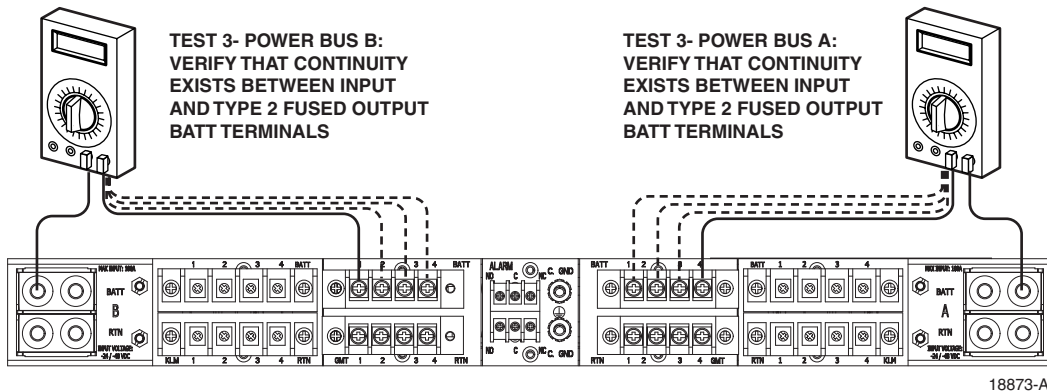

Figure 9. Test 2: Input Battery to Output Battery (Type 2 Fuse)

Test 3: Input Return to Output Return—Do the following test for each input power position and fuse type (refer to [Figure 10](#) and [Figure 11](#)).

1. Connect one test probe to the input power RTN (+) terminal
2. Connect the other test probe to the RTN terminal on the output power terminal block.
3. Verify that continuity exists between the specified terminals.

4. Repeat the test procedure for second fuse type, if present.
5. Repeat the test procedure for the second power bus, if present.

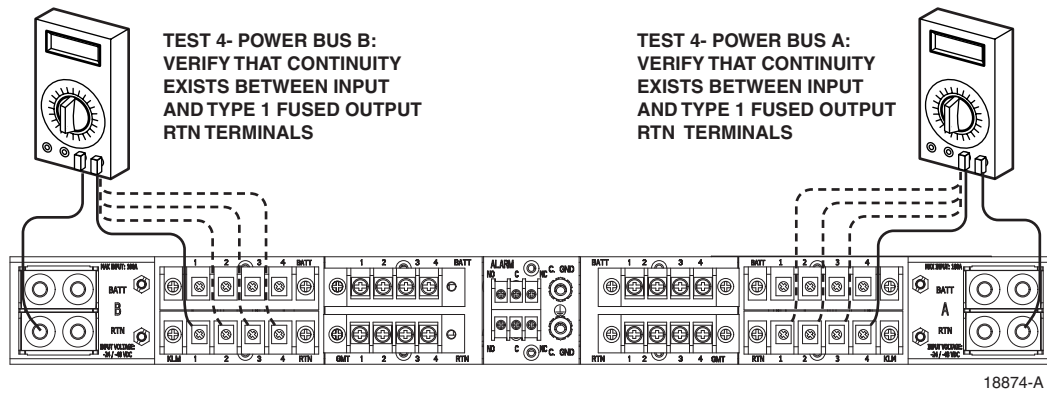

Figure 10. Test 3: Input Return to Fused Output Return (Type 1 Fuse)

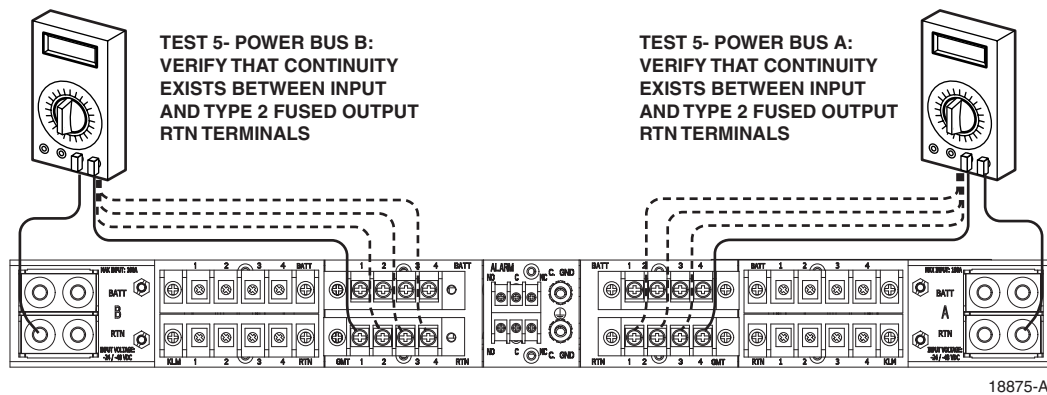

Figure 11. Test 3: Input Return to Fused Output Return (Type 2 Fuse)

Test 4: Alarm Terminals—Connect the test probes alternately between the C and NC terminals and the C and NO terminals on each set of alarm terminals. Verify that no continuity exists between the C and NC terminals and that continuity exists between the C and NO terminals.

If the fuse platform fails any of the specified tests, it is defective and must not be installed. Contact ADC (see [Section 8, Customer Information and Assistance on page 30](#)) for an RMA (Return Material Authorization) and to reorder if replacement is required.

4 INSTALLATION

This section provides procedures for mounting the fuse platform on a rack and installing wiring. Wiring includes input, grounding, alarm, and output wiring.

Caution: *This equipment employs electrical voltage and amperage levels which may be considered an electrical hazard. Care should be exercised to assure that only qualified personnel are allowed to install, operate, maintain, or otherwise come in contact with this equipment when the fuse platform is energized. Only insulated tools should be used on energized elements of the fuse platform.*

Warning: *Never install telephone equipment in a wet location or during a lightning storm. When installing or modifying telephone lines, disconnect lines at the network interface before working with uninsulated lines or terminals to prevent electrical shock.*

Warning: *Do not install fuses in fuse platform or power source until you have completed the power wiring connections.*

► **Note:** Do not apply power to the fuse platform until all testing and wiring are completed.

4.1 Installing Cable Management Bar (Optional Item)

Before installing the fuse platform in the rack, mount the cable management bar (accessory item) on the rear of the fuse platform as shown in Figure 12. Four 1/4-inch (6.35 mm) long 4-40 screws are provided with the cable management bar. The cable management bar can be recess mounted by using the mounting holes closest to the front of the fuse platform. Tighten all screws to 9 pound force-inches (1 Newton-meter) of torque to insure grounding.

Caution: *When attaching the cable management bar to the fuse platform, use only the 1/4-inch (6.350 mm) long 4-40 screws that are supplied with the cable management bar. Use of any other hardware could cause contact with internal parts of the fuse platform.*

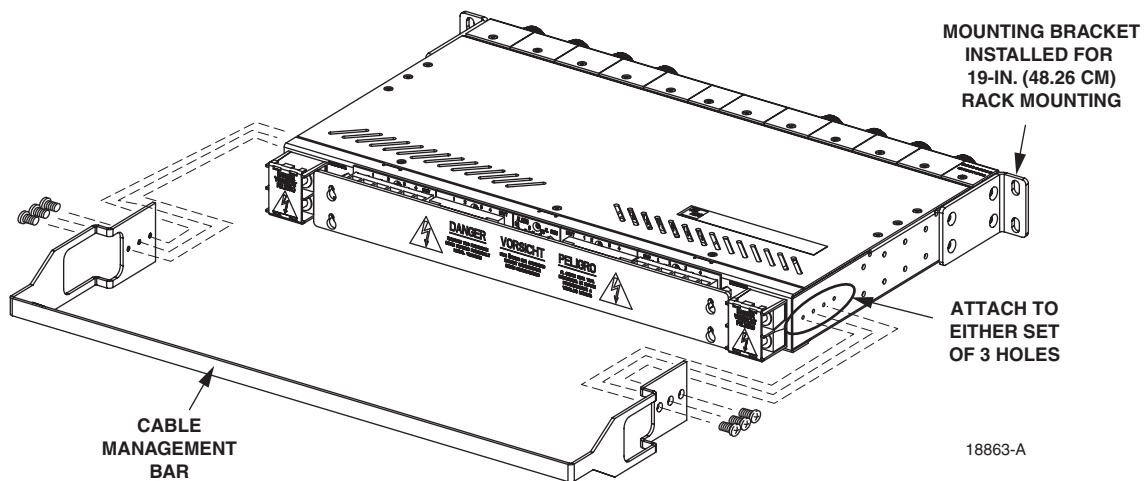

Figure 12. Cable Management Bar Installation

4.2 Mounting Fuse Platform on Rack

The fuse platform can be mounted in either a 19- or 23-inch (48.26 or 58.42 cm) wide rack. Two sets of mounting brackets, one set for 19-inch racks and one set for 23-inch racks, are provided with the fuse platform.

Eight 5/16-inch (7.936 mm) long, thread-forming, Phillips-drive, 8-32 flat-head screws are provided for attaching the mounting brackets to the panel. Four 3/8-inch (9.53 mm) long, Phillips-drive, 12-24 pan-head screws (with flat washers) are provided for attaching the mounting brackets to the equipment rack.

► **Note:** A fuse platform with the cable management bar attached may exceed the 12 inch (305 mm overall depth objective described in GR-63 CORE, 02-14.



Caution: When attaching the mounting brackets to the fuse platform, use only the 5/16-inch (7.94 mm) long, thread-forming, flat-head screws supplied with the fuse platform. Use of any other hardware could cause contact with internal parts of the fuse platform. If parts are missing, contact ADC to order replacement parts.

Use the following procedure to attach the mounting brackets to the fuse platform and to install the fuse platform in the equipment rack:

1. Select the set of mounting brackets (19- or 23-inch) that correspond to the width of the equipment rack into which the fuse platform will be installed.
2. Orient the mounting brackets as shown in [Figure 13](#).
3. Attach the brackets to the sides of the fuse platform using the eight 5/16-inch (7.94 mm) long flathead screws provided. Tighten screws to 15 pound force-inches (1.7 Newton meters) of torque to insure grounding.

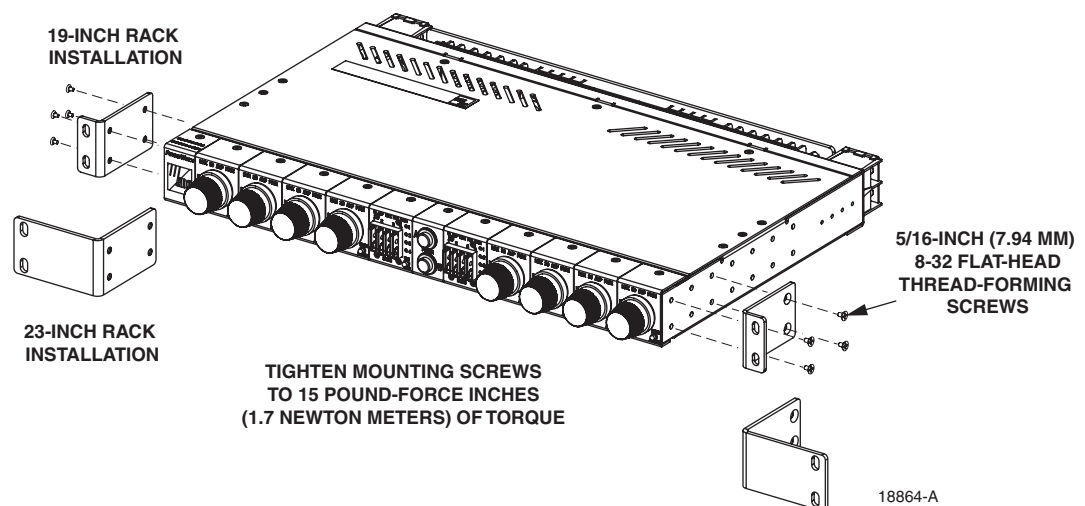

Figure 13. Mounting Brackets

4. Place the fuse platform in the specified mounting space within the rack.
5. Secure the fuse platform to the equipment rack as shown in [Figure 14](#) using the four 3/8-inch (9.53 mm) long pan-head screws and flat washers provided.



Caution: Do not use any hardware other than the hardware supplied with the fuse platform.

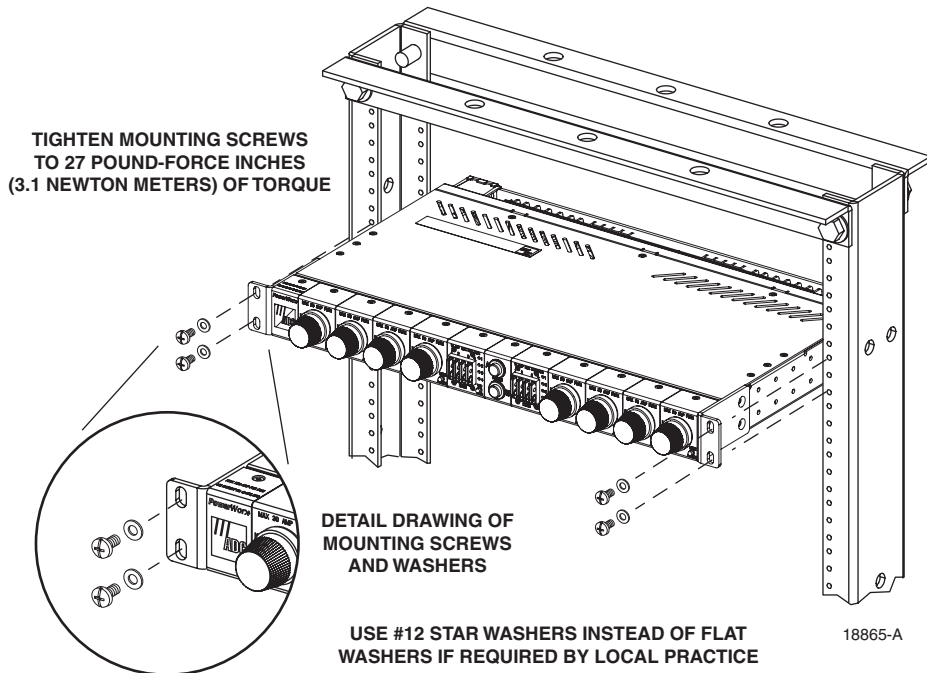

Figure 14. Mounting Fuse Platform on Rack

4.3 Grounding Chassis

Use the following procedure to connect the panel to an approved office ground source:

1. Obtain two lengths of #10 AWG wire for use as the chassis grounding wires.
- ▶ **Note:** A single ground wire can also be used. If using a single ground wire, use #6 AWG wire terminated at either stud.
2. Terminate one end of each wire with the #10 ring terminals provided (requires crimper).
3. Connect the ring terminal end of each wire to one of the studs and secure using the nuts with captive star washers provided (requires 3/8-inch socket). Tighten each stud nut to 23 pound-force inches (2.6 Newton meters) of torque.
4. Route the free end of each chassis grounding wire to an approved office ground source.
5. Cut each chassis grounding wire to length and connect it to the office ground source as required by local code or practice.

6. Locate the C GND (chassis ground) studs at the rear of the panel as shown in [Figure 15](#).

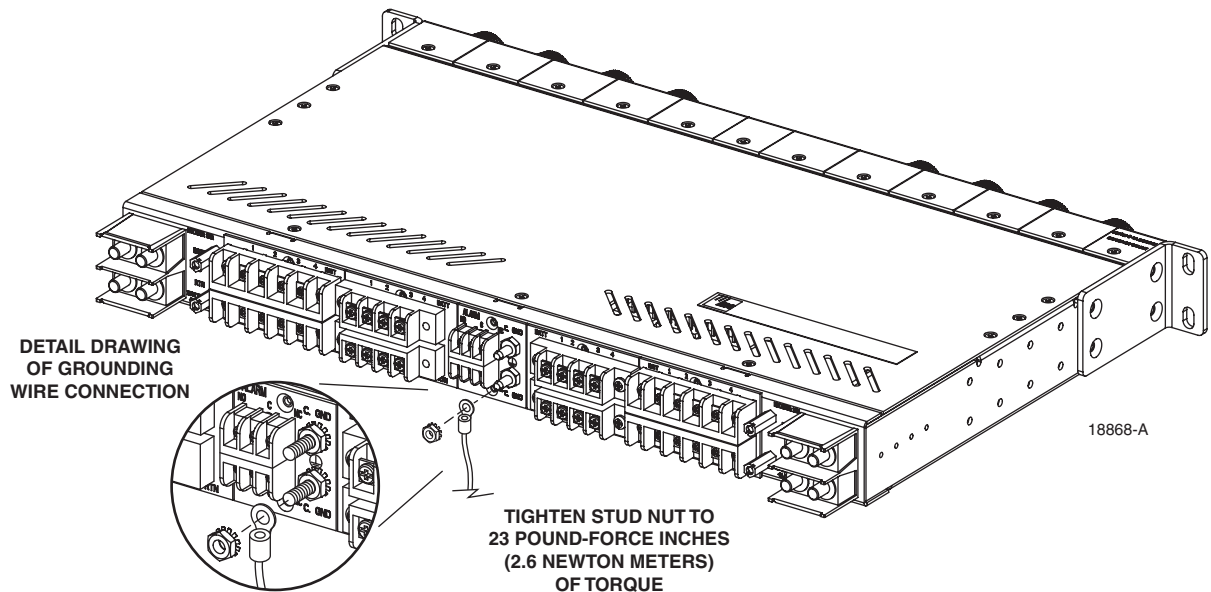

Figure 15. Chassis Ground Connections

4.4 Connecting Alarms

Depending on the model being installed, the fuse platform will have either of two types of alarm connectors on the rear side of the platform:

- Screw-down barrier terminal strip
- Wire wrap pin

[Figure 16](#) shows the two types. Connect the connectors as follows:

- Screw-down barrier terminal strip: The terminal screw size is 3-48. Terminate wire leads with crimp-on spade lug or ring connectors that have a maximum width of 0.200 (5.080 mm) or use #16 to #30 AWG copper wire without lugs (insulation stripped back). In selecting wire size, follow local code referring to the ampacity guidelines provided in Appendix A of this manual. Tighten the terminal screws to approximately 9 pound-inches (1 Newton-meter) of force.
- Wire-wrap terminal: Wrap terminal block pins using #22 to #26 AWG copper wire with insulation stripped back. In selecting wire size, follow local code referring to the ampacity guidelines provided in Appendix A of this manual.

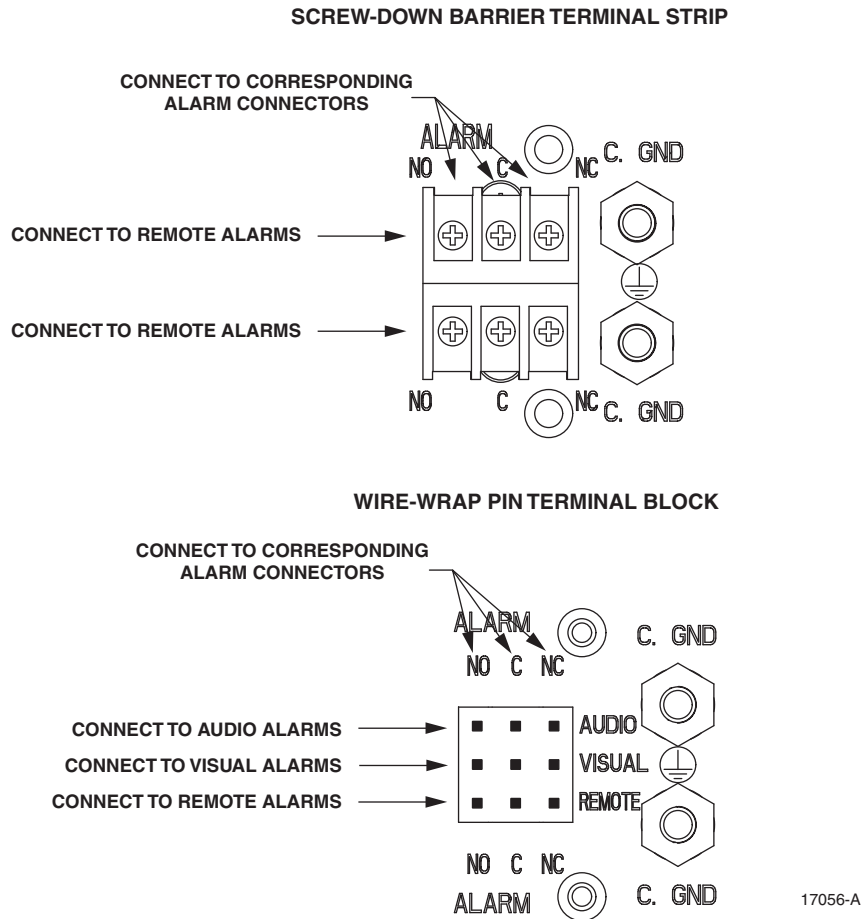

Figure 16. Alarm Contact Connections

4.5 Connecting Output Power

Output power is supplied to the equipment through screw-down barrier terminal strips located on the rear of the chassis. Each bus has separate strips for each fuse type. The terminal screws are of various sizes corresponding to the current load of the fuses. Each individual output has two terminals, battery (BATT) and return (RTN).

Connections are typically made using spade-type or ring connectors crimped onto the output power wires. [Table 1 on page 9](#) gives terminal screw size, maximum terminal width, and AWG # accepted for copper wire. In selecting wire size, follow local code referring to the ampacity guidelines provided in Appendix A of this manual.

Connect the output BATT and RTN terminals (see [Figure 17](#)) for each fused circuit to the appropriate set of terminal strips. Use the appropriate wire size with appropriate size crimp-on spade lugs or ring connectors or use the appropriate size wire with insulation stripped back at the wire end. Tighten the screws to approximately 9 pound force-inches (1 Newton-meter) of torque.

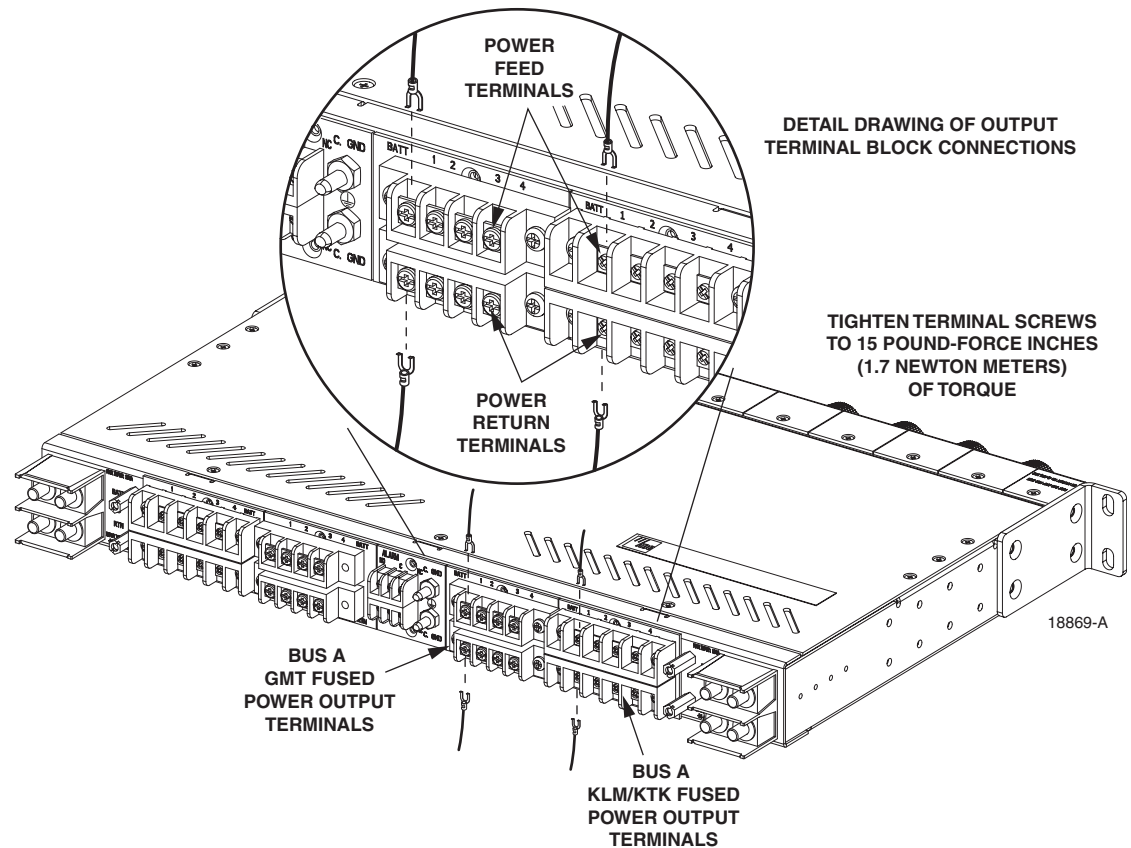

Figure 17. Output Power Connections



Caution: Connecting the equipment to the wrong circuit may cause damage to the equipment or the fuse platform. Make sure the fuse is the correct type and has the correct current rating as specified by the equipment manufacturer.

- ▶ **Note:** The continuous output load of the equipment during normal operation should not exceed 80% of the rated value of the fuse. This allows some room for manufacturing tolerances and voltage fluctuations in the plant power mains.

4.6 Connecting Input Power

Input power is supplied to the fuse platform through the single or dual terminal blocks located on the rear of the platform. Each input terminal block consists of two pairs of 0.25-inch studs that are used for connecting the BATT (battery –) and RTN (return +) input power cables.

The stud pairs are mounted on 0.625 inch centers and accept 2-hole compression lugs. The maximum lug width is 0.62 inches. Nuts with captive washers are provided to secure the compression lugs to the terminal block.



Warning: Use of one bus only on a dual bus panel will result in false alarms for the unused bus. Power is required on both buses on a dual bus panel for normal operation.



Caution: Connect only the input voltage wire [the wire labeled BATTERY or BATT, or labeled with the negative (-) voltage polarity and/or the voltage value] to the connector on the fuse platform labeled BATTERY. Connect only the input return wire [the wire labeled RTN, RETURN, or BATTERY GROUND, or labeled with the positive (+) voltage polarity] to the connector on the fuse platform labeled RETURN.



Caution: Caution should be taken to not reverse the input wires to the fuse platform. Within the panel, the internal return wiring is not protected by fuses. If the wires are reversed, current will flow through the unprotected return wiring in the panel to the equipment. This condition can cause damage to the equipment in the frame in which the panel is installed and to equipment in adjacent frames

Use the following procedure to connect the input power cables to the fuse platform:

1. Obtain eight lengths of #2 AWG wire for use as the input power cables.
2. Strip back 7/8 inches of insulation from one end of each wire as shown in [Figure 18](#).
3. Slide a 2-inch length of heat shrink insulation over the end of each wire.
4. Terminate one end of each wire with the 2-hole lug terminals provided (requires crimper).
5. Slide the heat shrink insulation down to the lug terminal so the barrel end of the terminal is covered.
6. Use a heat gun to apply heat to the heat shrink insulation until it tightens around the wire and barrel end of the terminal.
7. Form each input cable into the shape required for connection to the input terminals and secure to side of rack.

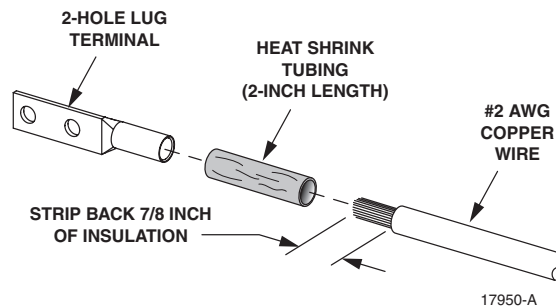

Figure 18. 2-Hole Lug Terminal Installation

8. Use the nuts (with captive star washers) provided to secure the input power wires to the two input power terminals as shown in [Figure 19](#). Each input power terminal has two terminals, labeled BATT and RTN. Connect the wires to the terminals as follows:
 - a. **Battery wires:** Connect to BATT (-) terminals on the A and B input power terminal blocks.

- b. **Return wires:** Connect to RTN (+) terminals on the A and B input power terminal blocks.
9. Use a torque wrench (with a 7/16-inch socket) to tighten the input power terminal block nuts to 32 pound-force inches (3.6 Newton meters) of torque.
10. Route the free end of each input power cable to the office battery source.

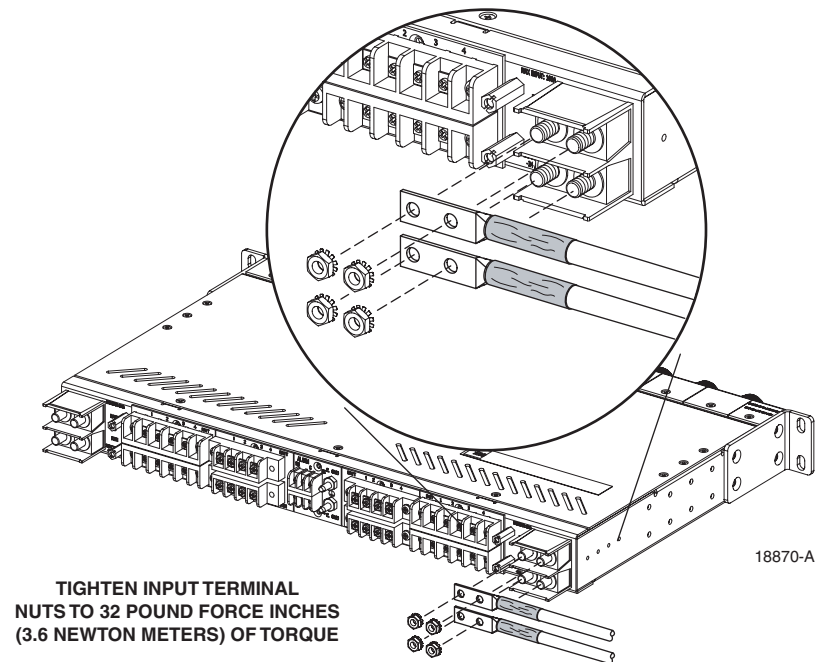

Figure 19. Input Power Connections

11. Connect the input power cables to the office battery power source in accordance with applicable local electrical codes and/or National Electrical Codes.



Caution: Do not apply power to the fuse platform until instructed to do so for testing (see [Section 6, Operation on page 28](#)).

4.7 Installing Protective Covers

Install the rear protective covers over the connectors at the rear of the fuse platform when all the wiring connections are completed. To identify the covers, see [Figure 1](#).

To install the plastic protective cover, thread the four 3/8-inch (9.53 mm) long, Phillips drive, 6-32 pan-head screws into the standoffs located between the output power screw-down terminal strips. Rotate each screw approximately two turns to get it started. Hold the cover so the lettering is oriented properly and then install the cover over the screw heads. Slide the cover to the left and then tighten the screws.

4.8 Installing GMT Fuse Designation Pins

Color-coded fuse designation pins (accessory item) are available for GMT fuses. The pin color corresponds to the color of the fuse indicator. Insert the appropriate color-coded pins (accessory item) into the corresponding holes in each GMT fuse holder as required.

4.9 Installing Fuse Designation Card Holder and Card

Attach the fuse designation card holder to the fuse platform, to one of the fuse platform mounting brackets, or to a part of the rack. Remove the backing from the back of the card holder and press the card holder against the mounting surface. Fill out one of the cards with the required circuit information insert it in the card holder.

4.10 Installing Voltage Designation Label

Write the voltage used in the fuse platform on the voltage designation label and attach the label to the back of the fuse platform.

5 SYSTEM CHECK

Perform the following procedures to check out the platform after completing installation.

5.1 Wiring Connections Torque Measurements

Measure the torque of all input, output, chassis ground and fuse alarm relay contact connections included in the non-powered testing paragraphs above using a torque screwdriver that is calibrated in pound force-inches (Newton-meters). The torque specifications are printed on the rear of the panel adjacent to the connector.

5.2 Power On and Connection Polarity Test

Use the following procedure to apply power to the fuse platform and verify that the power input wires are connected correctly:

► **Note:** This procedure assumes that no fuses have been installed yet.

1. Verify that the input power cables are connected to the correct terminals.
2. Verify that the circuit breakers for all circuits are on.
3. Apply power to the unit.
4. Verify that the power-on indicator (green LED) for each power bus is lit. (The fuse platform being installed may have either one or two power buses.)
5. Verify that no fuse alarm LEDs on the front of the fuse platform are red or green.

6. Using a multimeter set to measure DC voltage, measure the voltage between each input power (RTN) terminal and chassis ground. The voltage level should be less than 2.0 Vdc.
7. If the voltage is much higher, and reads out in the –21 to –60 Vdc range, the input leads are probably reversed. If this appears to be true, power down the panel. Disconnect the negative (BATT) and positive (RTN) input lugs and switch them around. Power up the panel and check again to verify that the higher voltage is on the negative (BATT) lug.
8. If the problem is such that you can't figure it out with these instructions, consult with ADC Technical Assistance Center (TAC).

5.3 GMT Fuse Alarm Test and Installation

If the fuse platform being installed is equipped for GMT fuses, use the following procedure to test or install a GMT fuse. Fuse platforms equipped for GMT fuses are shipped with dummy fuses in the GMT fuse holders.

To test the fuse alarm indicator for the GMT fuses, replace a dummy fuse with a known failed fuse. The visual fuse alarm LED for that bank of fuses will change from unlit to lit (red light), and the fuse alarm relay will operate. After testing, remove the failed fuse and install a dummy fuse in any fuse position that will not be used.

To install a fuse, replace the dummy fuse with a good fuse.

5.4 TPA Fuse Alarm Test and Installation

If the fuse platform being installed is equipped for TPA fuses, use the following procedure to test or install a TPA fuse. Fuse platforms equipped for TPA fuses are shipped with no fuses installed in the TPA fuse positions.

To test a TPA fuse alarm indicator, install a known failed fuse in the position of interest. Verify that the fuse alarm LED is lit (red light). Verify that the fuse alarm relay indicates a closed circuit between the NO contact and the C contact at the fuse alarm contacts. After testing, remove the failed fuse.

To install a TPA fuse, insert the fuse in the selected position. Verify that the visual fuse alarm indicator for that fuse is unlit.

5.5 KLM Fuse Alarm Test and Installation

If the fuse platform being installed is equipped for KLM fuses, use the following procedure to test or install a KLM fuse. Fuse platforms equipped for KLM fuses are shipped with no fuses installed in the KLM fuse positions.

► **Note:** The KLM fuse alarm LED has two color states, red and green.

To test the KLM fuse alarm indicator, use the following procedure:

1. With the fuse platform powered and no KLM fuses installed, verify that no fuse alarm LEDs are lit (no red or green light). Verify that the fuse alarm relay indicates an open circuit between the NO contact and the C contact at the fuse alarm contacts.
2. Insert a known good KLM fuse in each position to be used, one at a time, and verify that the corresponding fuse alarm LED turns green. Verify that the fuse alarm relay indicates an open circuit between the NO contact and the C contact at the fuse alarm contacts.
3. Remove the KLM fuse in each position, one at a time, and verify that the corresponding fuse alarm LED turns red. Verify that the fuse alarm relay indicates a short circuit between the NO contact and the C contact at the fuse alarm contacts.
4. Insert a known good KLM fuse in each position, one at a time, and verify that the corresponding fuse alarm LED turns green. After approximately ten seconds, the LED will begin to flash. Remove the KLM fuse and verify that the corresponding fuse alarm is not lit (no red or green light). Once all the fuse alarm LEDs are not lit, verify that the fuse alarm relay indicates an open circuit between the NO contact and the C contact at the fuse alarm contacts.

► **Note:** There is less than 1 volt present at a non-active KLM fuse position.

To install a KLM fuse, insert the fuse in the selected position, as in the procedure above. Verify that the visual fuse alarm LED for that fuse is green.

6 OPERATION



Caution: *This equipment employs electrical voltage and amperage levels which may be considered an electrical hazard. Care should be exercised to assure that only qualified personnel are allowed to install, operate, maintain, or otherwise come in contact with this equipment when the fuse platform is energized. Only insulated tools should be used on energized elements of the fuse platform.*

All fuse platform circuits are operational as soon as power is applied to the input connectors. The alarm indicator should not light when power is applied.

Operation of the fuse platform consists of removing and replacing fuses when a fuse fails. If a fuse fails, the alarm indicator lights, and the external and remote alarms are activated (if present).

6.1 Clearing a KLM Fuse Alarm

If the operator wants to clear an alarm in a KLM fuse position without leaving a new fuse installed, the following steps are required:

1. Using a good KLM fuse borrowed from another location, replace the failed fuse with the good fuse, causing the LED to turn green and the alarm to be cleared.

2. Wait about ten seconds until the green LED starts to blink off and on, which it will do five times.
3. While the LED is blinking, remove the good fuse just installed. If the fuse is removed during this flashing, the fuse position will go to a non-used status and no alarms will be present. The LED will turn off and remain unlit until a new fuse is installed.
4. Return the removed fuse to its original location.

7 MAINTENANCE



Caution: *This equipment employs electrical voltage and amperage levels which may be considered an electrical hazard. Care should be exercised to assure that only qualified personnel are allowed to install, operate, maintain, or otherwise come in contact with this equipment when the fuse platform is energized. Only insulated tools should be used on energized elements of the fuse platform.*

7.1 Inspection

Inspect the fuse platform periodically (every six months is recommended) for damage to the fuses and for damaged or broken wires on the power outputs and the external alarm connections. Inspect for excessive dust and dirt that may block the vents.

7.2 Cleaning

If excessive dirt is found during the inspection, brush or wipe dust and dirt from the fuse platform with a soft bristle brush or soft cloth. Take care not to damage the fuses or any wiring.

7.3 Fuse Removal

The GMT fuses can be removed with the aid of a wire hook or tweezers-type fuse puller. A fuse puller is available as an accessory item. A TPA or KLM fuse may be removed by pulling the fuses straight out from the fuse holders.

8 CUSTOMER INFORMATION AND ASSISTANCE

PHONE:

U.S.A. OR CANADA

Sales: 1-800-366-3891 Extension 73000

Technical Assistance: 1-800-366-3891

Connectivity Extension 73475

Wireless Extension 73476

EUROPE

Sales Administration: +32-2-712-65 00

Technical Assistance: +32-2-712-65 42

EUROPEAN TOLL FREE NUMBERS

Germany: 0180 2232923

UK: 0800 960236

Spain: 900 983291

France: 0800 914032

Italy: 0800 782374

ASIA/PACIFIC

Sales Administration: +65-6294-9948

Technical Assistance: +65-6393-0739

ELSEWHERE

Sales Administration: +1-952-938-8080

Technical Assistance: +1-952-917-3475

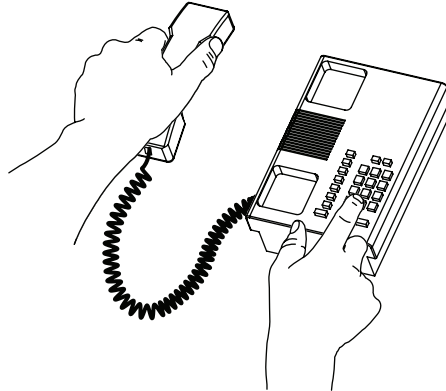

WRITE:

ADC TELECOMMUNICATIONS, INC
PO BOX 1101,
MINNEAPOLIS, MN 55440-1101, USA

ADC TELECOMMUNICATIONS (S'PORE) PTE. LTD.
100 BEACH ROAD, #18-01, SHAW TOWERS.
SINGAPORE 189702.

ADC EUROPEAN CUSTOMER SERVICE, INC
BELGICASTRAAT 2,
1930 ZAVENTEM, BELGIUM

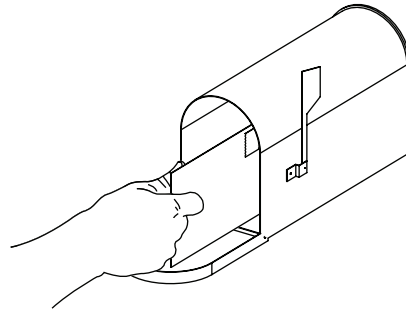

PRODUCT INFORMATION AND TECHNICAL ASSISTANCE:

connectivity.tac@adc.com

wireless.tac@adc.com

euro.tac@adc.com

asiapacific.tac@adc.com

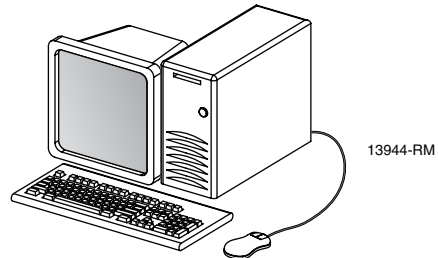

Contents herein are current as of the date of publication. ADC reserves the right to change the contents without prior notice. In no event shall ADC be liable for any damages resulting from loss of data, loss of use, or loss of profits and ADC further disclaims any and all liability for indirect, incidental, special, consequential or other similar damages. This disclaimer of liability applies to all products, publications and services during and after the warranty period. This publication may be verified at any time by contacting ADC's Technical Assistance Center.



© 2006, ADC Telecommunications, Inc.
All Rights Reserved
Printed in U.S.A.

APPENDIX A: ALLOWABLE AMPACITIES OF INSULATED CONDUCTORS

This appendix provides guidelines for selecting AWG wire size based on the temperature rating of the conductor and the anticipated load. The information contained is from Table 310-16 of the National Electrical Code document, ANSI/NPFA 70 (1978).

- **Note:** Information for aluminum conductors has been omitted from the table here because copper conductors only are recommended for use with the ADC panel.

Table 310-16 (NEC): Allowable Ampacities of Insulated Conductors, Rated 0 Through 2000 Volts, 60° to 90°C (140° to 194°F), Not More Than Three Current-Carrying Conductors in Raceway or Cable or Earth (Directly Buried), Based on Ambient Temperature of 30°C (86°F)

SIZE AWG KCMIL	TEMPERATURE RATING OF CONDUCTOR		
	60°C (114°F)	60°C (114°F)	60°C (114°F)
	TYPES TW*, UF*	TYPES FEPW*, RH*, RHW*, THHW*, THW*, THWN*, XHHW*, USE*, ZW*	TYPES TBS, SA, SIS, FEP*, FEPB*, MI, RHH*, RHW-2, THHN*, THHW*, THW-2*, THWN-2*, USE-2, XHH, XHHW*, XHHW-2 ZW-2
18	14
16	18
14	20*	20*	25*
12	25*	25*	30*
10	30	35*	40*
8	40	50	55
6	55	65	75
4	70	85	95
3	85	100	110
2	95	115	130
1	110	130	150
1/0	125	150	170
2/0	145	175	195
3/0	165	200	225
4/0	195	230	260
250	215	255	290
300	240	285	320
350	260	310	350
400	280	335	380

Table 310-16 (NEC): Allowable Ampacities of Insulated Conductors, Rated 0 Through 2000 Volts, 60° to 90°C (140° to 194°F), Not More Than Three Current-Carrying Conductors in Raceway or Cable or Earth (Directly Buried), Based on Ambient Temperature of 30°C (86°F)

SIZE	TEMPERATURE RATING OF CONDUCTOR		
	60°C (114°F)	60°C (114°F)	60°C (114°F)
			TYPES TBS, SA, SIS, FEP*, FEPB*, MI, RHH*, RHW-2, THHN*, THHW*, THW-2*, THWN-2*, USE-2, XHH, XHHW* XHHW-2 ZW-2
	TYPES TW*, UF*	TYPES FEPW*, RH*, RHW*, THHW*, THW*, THWN*, XHHW*, USE*, ZW*	
500	320	380	430
600	355	420	475
700	385	460	520
750	400	335	380
800	410	490	555
900	435	520	585
1000	455	545	615
1250	495	590	665
1500	520	625	705
1750	545	650	735
2000	560	665	750
CORRECTION FACTORS			
For ambient temperatures other than 30C (86F), multiply the allowable ampacities shown by the appropriate factor shown below.			
21-25	1.08	1.05	1.04
26-30	1.00	1.00	1.00
31-35	.91	.94	.96
36-40	.82	.88	.91
41-45	.71	.82	.87
46-50	.58	.75	.82
51-55	.41	.67	.76
56-6058	.71
61-7033	.58
71-8041

* Unless otherwise specifically permitted in the code, as defined in the NEC document cited (ANSI/NEC 70), the overcurrent protection for conductor types marked with an asterisk (*) shall not exceed 15 amperes for No. 14, 20 amperes for No. 12, and 30 amperes for No. 10 copper, after any correction factors for ambient temperature and number of conductors have been applied.



www.adc.com