

# QuickStart Guide

D-390 / C-150

**OLYMPUS AMERICA INC.**  
Two Corporate Center Drive, Melville,  
NY 11747-3157, U.S.A.  
<http://support.olympusamerica.com/>

**OLYMPUS OPTICAL CO. (EUROPA) GMBH**  
Wendenstrasse 14-18,  
20097 Hamburg, Germany  
<http://www.olympus-europa.com>

**OLYMPUS**

<http://www.olympus.com/>

## START HERE

It is strongly recommended that you follow these step-by-step numbered instructions to set up and quickly begin using your new Digital Camera.

For more detailed instructions on advanced features, please refer to the printed Basic Manual included in your package, or the Reference Manual on the CD-ROM.

## 1 UNPACKING THE BOX CONTENTS

Gather your digital camera and the parts as shown in the illustration. You'll need these to complete the steps for the camera set-up procedures that follow.

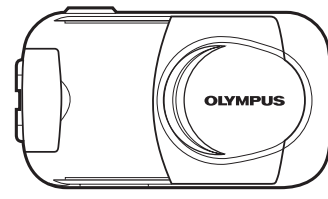

Digital camera



Strap

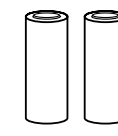

AA (R6) alkaline  
batteries (x2)

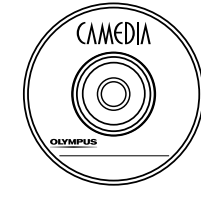

CAMEDIA  
Master CD-ROM

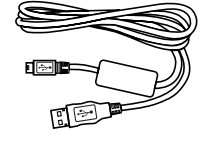

USB cable  
(grey color)



xD-Picture Card

The following items are also included in this package: Basic Manual, video cable, warranty card, registration card (not provided in some areas), and safety precautions booklet.

## 2 PREPARE THE CAMERA FOR USE

Before you begin using your Olympus digital camera...

### a. Loading batteries

- Slide the battery compartment cover in the direction of (A) (the direction indicated by the mark on the cover), and lift it up in the direction of (B).

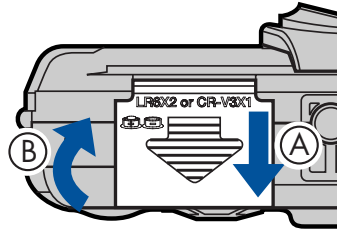

- Insert batteries in the direction shown in the illustration.

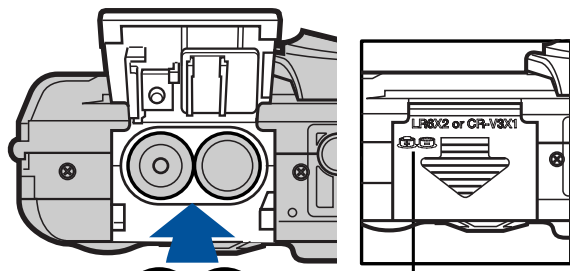

There is a mark on the bottom of the camera showing the correct way to insert batteries.

- Close the battery compartment cover so that it pushes the batteries down inside. While pressing the mark, slide the cover in the opposite direction of .

**TIP:** An optional Olympus E-7AC AC adapter is available, and is recommended when downloading images to ensure a consistent power supply. **See the Basic Manual for more information.**

### b. Insert the xD-Picture Card

The xD-Picture Card is where the camera stores your pictures and is available in a variety of memory capacities. The pictures you take with the camera remain on the xD-Picture Card even when the camera is turned off and/or the batteries are removed.

- Insert the xD-Picture Card into the spring-loaded card slot as shown in the illustration. Push the card fully into the slot. The card will lock into place when fully inserted.
- To remove, push down on the xD-Picture Card. The card will pop up. Pull to remove.
- Close the card cover.

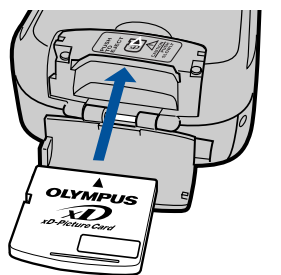

Confirm you have installed the batteries and xD-Picture Card properly by pressing . The "No Picture" message should be displayed in the monitor. Turn the camera off by pressing again.

### c. Attach the strap (OPTIONAL)

Attach the strap as illustrated to make the camera easier to handle.

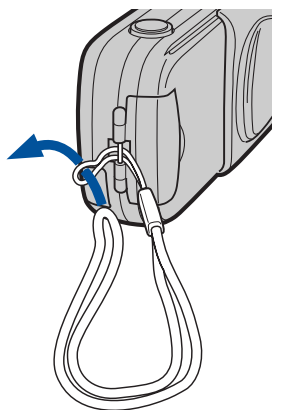

## 3 TURNING ON THE CAMERA

All you need to do is slide the lens barrier open or closed to turn the camera ON or OFF.

### a. Turn the camera ON (SHOOTING MODE)

- Open the lens barrier.
- Close the lens barrier to turn the camera off.

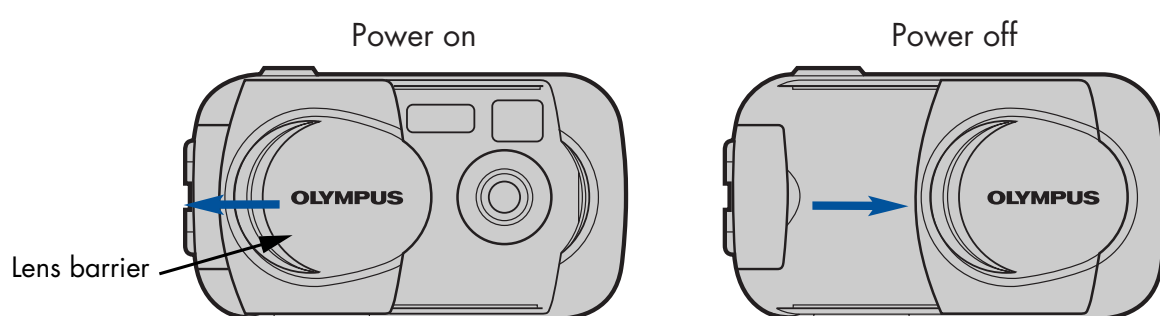

**TIP:** To maximize battery life, this digital camera features a power saving mode in which the camera enters a sleep mode after approximately three (3) minutes of non-use. Press the shutter button to wake up the camera.

### b. Set the Date and Time (OPTIONAL)

Although this is not required, it is recommended that you set the date and time. This affects the way image file names are created, and will conveniently include this information with each picture. The date and time can also be set when the camera is in the playback mode.

- Open the lens barrier fully until it clicks.
- Press to display the menu.
- Press to select MODE MENU.
- Press three times to select SETUP.
- Press once, and then twice to highlight , and then press once.
- Use and to select the date format.
- Adjust the date and time in the appropriate fields by using to select the field, and to set the proper value. Repeat this step until all date/time fields have been set.

**Note:** Time is entered using the 24-hour format.

- Press twice to set the date and time and exit the menu.

### c. Camera Diagram and Controls

Now take a moment to familiarize yourself with the key areas of camera controls by reviewing the illustrations.

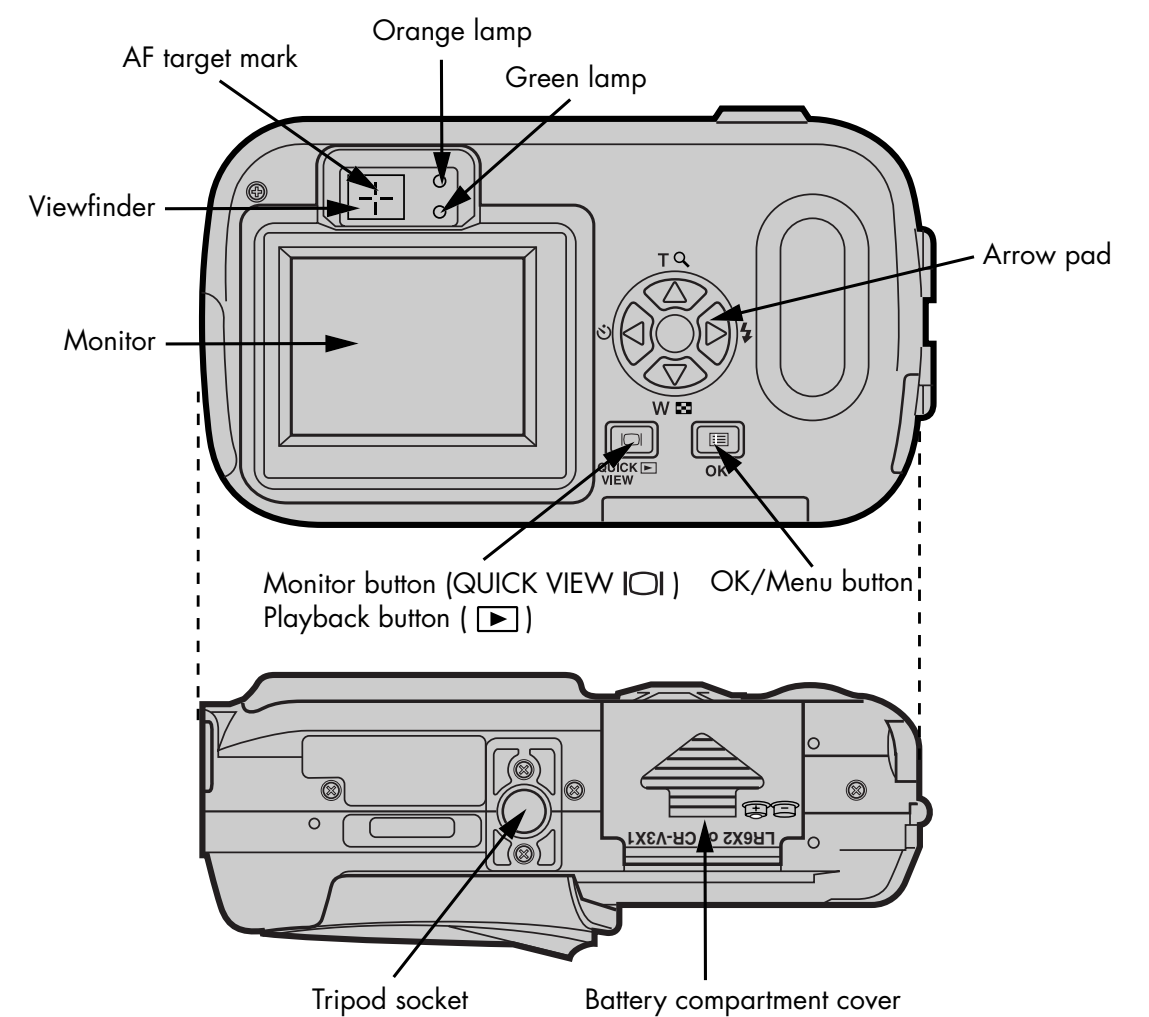
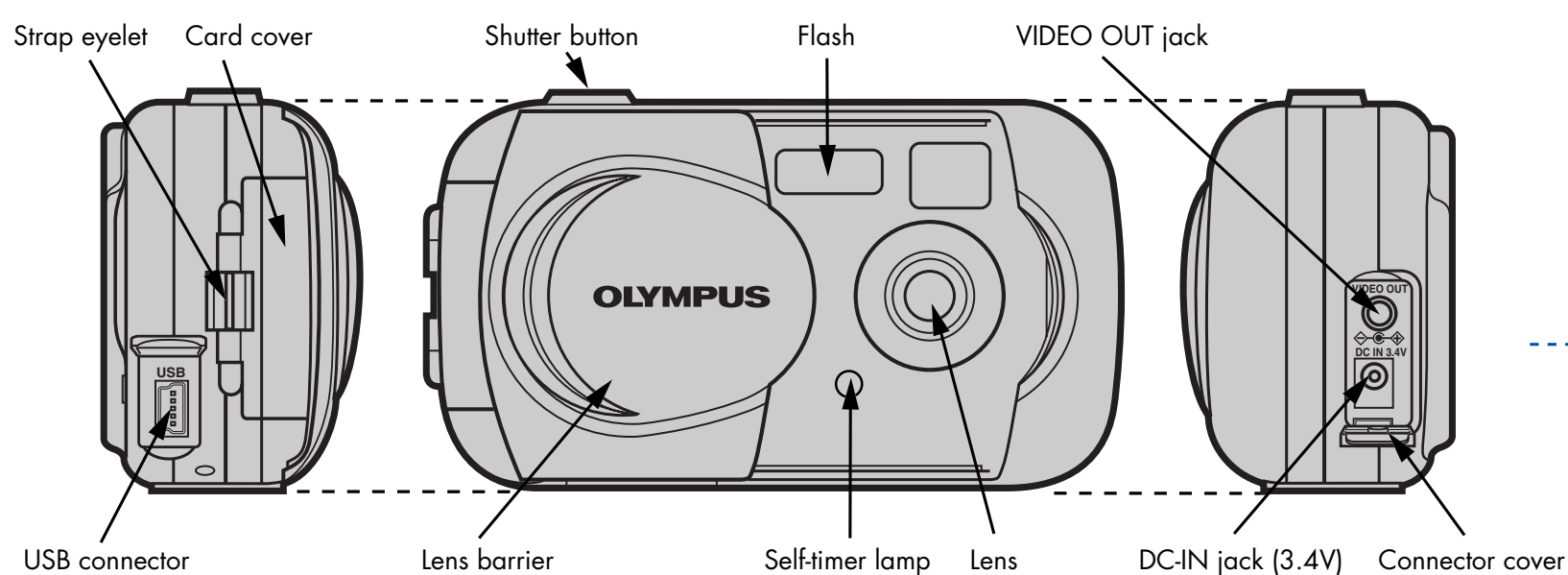

#### Camera Settings in Shooting Mode as shown in Monitor

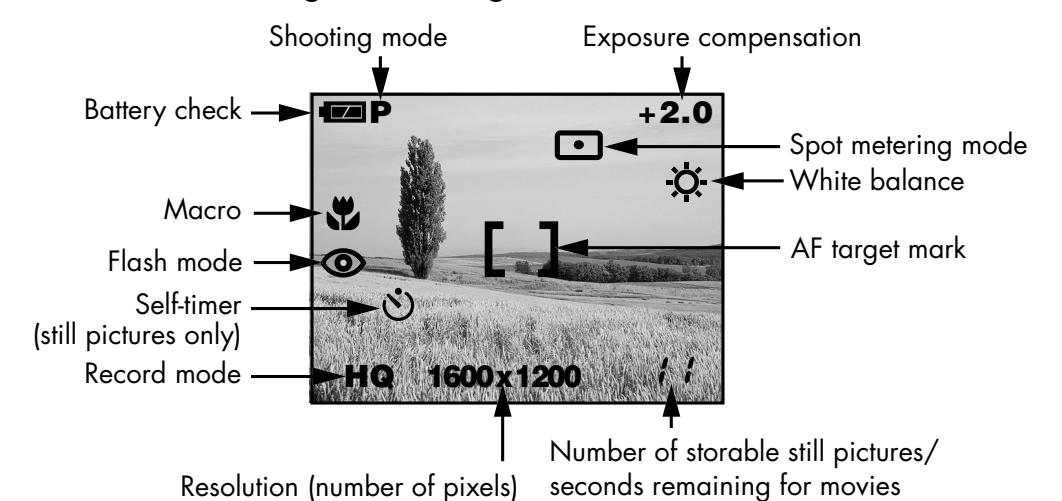

#### Camera Settings in Playback Mode as shown in Monitor

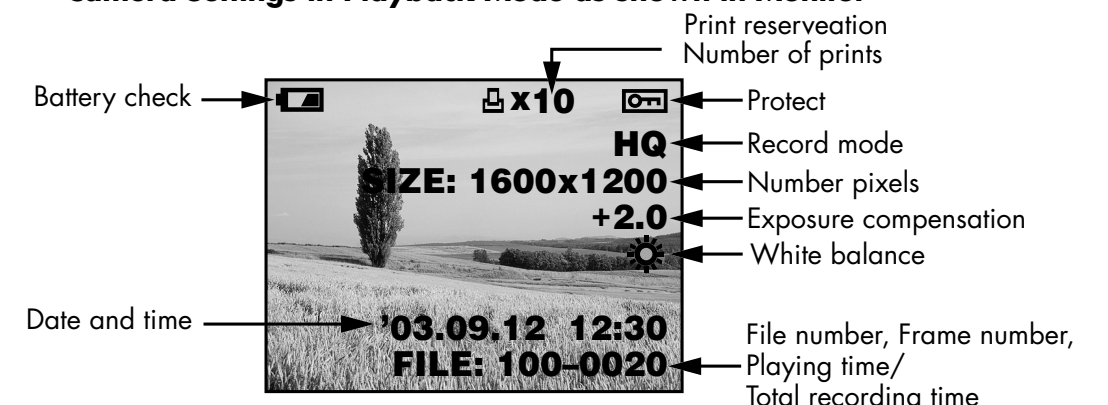

**Note:**

- Depending on the camera settings, not all indicators will be displayed.



# 4 TAKING PICTURES

There are two ways to compose your subject: with the viewfinder or using the monitor. Depending upon the shooting situation, there may be advantages to each method. Please refer to the printed Basic Manual for more information.

## a. Taking a Picture with the Viewfinder

- Open the lens barrier fully.
- Frame your subjects using the AF target mark in the viewfinder.
- Press the shutter button halfway.

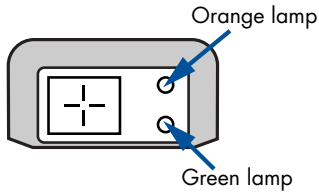

The digital camera confirms the focus and exposure are properly set when the green lamp in the viewfinder lights steadily. The orange lamp informs you that the flash is recommended and/or recharging (when blinking); or ready to fire (when steady).

- Press the shutter button completely to take the picture. A short beep confirms your picture has been taken.

## b. Taking a Picture with the Monitor

- Open the lens barrier fully.
- Press **MON** and then frame your subject using the full-color monitor.



Icons representing camera settings appear on the monitor, telling you important information such as the Flash and record modes, battery life, and the number of frames remaining.

- Press the shutter button halfway. The green lamp will light steadily when the focus and exposure are set.
- Press the shutter button completely to take the picture. A short beep confirms your picture has been taken.

## c. Zooming

You can enlarge your subject when shooting by 1.3, 1.6, 2.0 or 2.5 times.

Each time you press **Q**, the zoom magnification changes in the following sequence:  
1.3 times → 1.6 times → 2.0 times → 2.5 times.

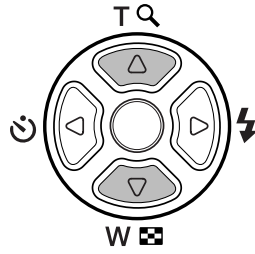

Each time you press **W**, the zoom magnification changes in the following sequence:  
2.5 times → 2.0 times → 1.6 times → 1.3 times.

- The zoom magnification changes continuously while holding down **Q** or **W**.

## d. Flash Modes

This digital camera features multiple flash modes.

Icon	Flash Mode	Description
No icon	Auto-flash	The camera automatically decides if the flash is needed.
	Red-eye Reduction Flash	Reduces incidence of red-eye by emitting pre-flashes to shrink pupil size before firing the main flash. The strobe effect is normal operation for this mode.
	Fill-in Flash	The flash always fires with every picture.
	Flash Off	Turns the flash off for times when flash photography is prohibited or not desired. The flash never fires.

Press **FLASH** to cycle through the available flash modes. With the shutter button depressed halfway, the flash is ready to fire when the orange lamp next to the viewfinder lights steadily. When the orange lamp is blinking, the flash is charging.

## e. Number of Storable Pictures

Your digital camera can handle xD-Picture Card from 16 MB to 256 MB. The number of storable pictures depends on the image quality selected.

See the Reference Manual for complete descriptions of each record mode and the storable frame capacity for the various resolution modes and xD-Picture Card capacities.

**TIP:** To find out how many frames you have left, turn on the monitor and look for the number in the lower right corner. Remember, you can always delete unwanted pictures to make room for more. (See Step 5.)

# 5 VIEWING AND ERASING PICTURES

With this digital camera, you can easily view the photos you want—and delete the ones you don't.

## a. Viewing Pictures

There are two ways to access the Playback mode:

- If the camera is OFF and the lens barrier closed, press **PLAY** once.
- OR**
- If the camera is in the shooting mode with the lens barrier fully open, press **MON** twice in rapid succession (Quick View).

The last picture taken appears in the monitor. Use **LEFT** and **RIGHT** to scroll through all the images saved on your xD-Picture Card.

When you are finished reviewing your pictures:

- Press **PLAY** to turn the camera off.
- OR**
- To return back to the shooting mode, press the shutter button halfway.

## b. Erasing Pictures

The beauty of digital photography is your ability to keep the photos you want, delete the rest, and reuse empty memory space to take new pictures. This digital camera offers two ways to permanently erase unwanted digital photos:

**Single-Frame Erase:** Deletes only the picture currently displayed in the monitor.

**⚠ Once erased, pictures cannot be restored.**

- With the lens barrier closed, press **PLAY** and use the arrow pad to display the picture you want to erase.
- Press **OK**. Press **LEFT** to select **ERASE**.
- Press **RIGHT** to select YES, and then press **OK**.

**TIP:** Images can also be erased while in the "Quick View" mode described in step 5A. This makes it easy to quickly erase a picture that you just took.

**All-Frame Erase:** Deletes all pictures on the xD-Picture Card in one operation, except for pictures you have protected.

**⚠ Once erased, pictures cannot be restored.**

- With the lens barrier closed, press **PLAY**.
- Press **OK**, then press **LEFT** to select **MODE MENU**.
- Use **LEFT** and **RIGHT** to select the **CARD** tab, then press **LEFT** twice to access the **CARD SETUP** screen.
- **ALL ERASE** should be highlighted. Press **OK**.
- As a safeguard, this digital camera will ask you to select YES or NO to confirm erasing, as this process permanently deletes all unprotected pictures. Select YES and press **OK**.

# 6 CONNECTING THE CAMERA TO A COMPUTER

**TIP:** Olympus recommends using the optional E-7AC AC adapter to ensure a consistent power supply when downloading images.

**⚠ Make sure that the camera is turned off before connecting it to your computer.**

Olympus makes it simple to connect this digital camera to your computer.

- Turn the camera off.
- Plug the supplied USB cable into the ports on your camera and computer as illustrated at right.

**⚠ Windows 98 users must install the "USB Driver for Windows 98" software before connecting this digital camera to the computer. Refer to the Software Installation Guide for complete information.**

- Press the **PLAY** button if the camera does not turn on automatically. The camera starts communicating with the PC.

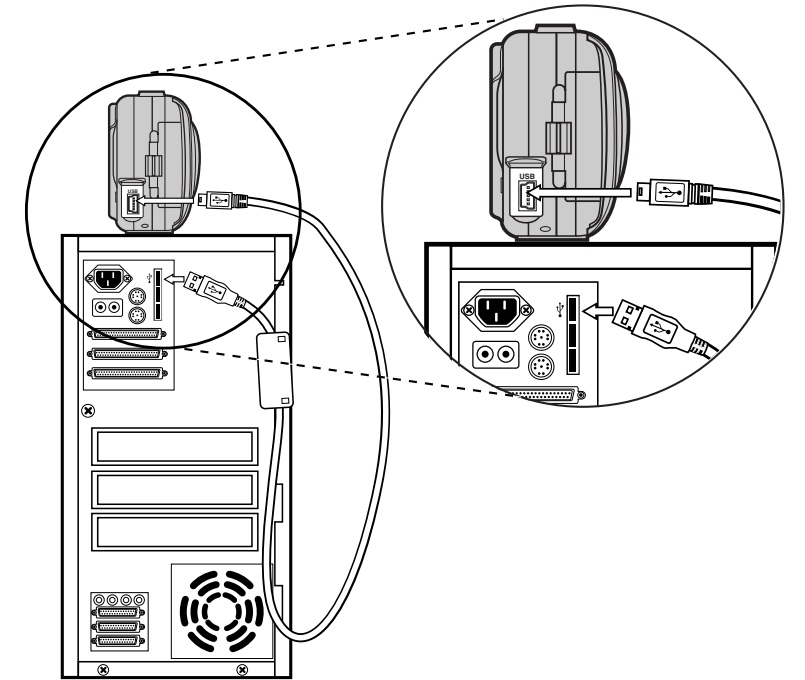

# 7 INSTALLING THE CAMERA SOFTWARE

You've now mastered the basic functionality of your new Olympus digital camera! You are now ready to begin exploring the possibilities that digital photography brings to your computer. Activities such as photo editing, printing, and much more are only steps away!

## About the Olympus CAMEDIA Master CD-ROM

Your Olympus digital camera comes bundled with a suite of software and documentation. The CD includes:

- **CAMEDIA Master** : To download pictures from the camera, view, organize, retouch, and print your digital photos and movies.
- **USB Driver for Windows 98**: This utility must be installed to allow the camera to communicate with your computer if it uses the Microsoft Windows 98 operating system.
- **Olympus Digital Camera Reference Manual**: A complete reference guide in digital form, saved on the CD in PDF format.

## You are now ready to install the computer software.

- Open the CAMEDIA Master CD-ROM package and locate the Software Installation Guide in the language you wish to use.
- Continue to follow the step-by-step instructions for installing the software, and enjoy your new digital photo processing capabilities!

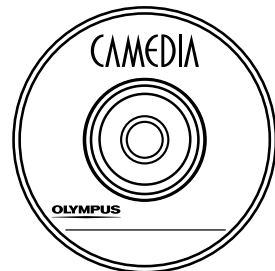

## Additional Camera Features

This digital camera offers a host of advanced features to expand your creativity. Here's just a small sampling. See the Basic Manual for details on these capabilities, and more!

- **4 Scene Program Shooting Modes:** This camera has 4 shooting modes to choose from depending on the shooting conditions and the effect you want to achieve.
- **Macro Mode:** For close-ups as tight as 8 inches, select Macro Mode.
- **Movie Mode:** Yes, this digital camera records movies! (Movie Mode does not record sound.)
- **Two-in-one Pictures:** Combine two separate images taken in succession and store them as a single picture.
- **Close-up Playback:** Enlarge the pictures in the monitor to check details of the selected image.
- **Index Display:** View several thumbnail pictures on the monitor at once.
- **Protecting Pictures:** Prevents you from accidentally erasing photos.
- **Video Playback:** View your pictures and movies on a television monitor.
- **Panorama Shooting:** Connect overlapping images into a single picture using the panorama mode and Olympus CAMEDIA Master software.

**TIP:** Remember to complete and return your Registration Card, and keep all camera documentation handy.

**Technical Support (USA)**  
1-888-553-4448 (Toll-free)  
8:00 AM - 10:00 PM ET  
Monday - Friday

**European Technical Customer Support**  
00800-67 10 83 00 (Toll-free)  
+49(0)1805-67 10 83 or +49(0)40-23 77 38 99 (Charged)  
9:00 AM - 6:00 PM MET  
Monday - Friday